

# CSMC 412

## Operating Systems Prof. Ashok K Agrawala

© 2022 Ashok Agrawala

# Intel x86 Architecture

# X 86 vs x64

Operating mode	Operating sub-mode	<a href="#">Operating system</a> required	Type of code being run	Default address size	Default operand size	Supported typical operand sizes	<a href="#">Register file</a> size
<a href="#">Long mode</a>	64-bit mode	64-bit	<a href="#">64-bit code</a>	64 bits	32 bits	8, 16, 32, or 64 bits	16 registers per file
	Compatibility mode		<a href="#">32-bit code</a>	32 bits	32 bits	8, 16, or 32 bits	8 registers per file
			<a href="#">16-bit code</a>	16 bits	16 bits	8, 16, or 32 bits	8 registers per file
Legacy mode	<a href="#">Protected mode</a>	32-bit	<a href="#">32-bit code</a>	32 bits	32 bits	8, 16, or 32 bits	8 registers per file
		16-bit protected mode	<a href="#">16-bit code</a>	16 bits	16 bits	8, 16, or 32 bits <sup>[m.1]</sup>	8 registers per file
	<a href="#">Virtual 8086 mode</a>	16-bit protected mode or 32-bit	some of <a href="#">real mode code</a>	16 bits	16 bits	8, 16, or 32 bits <sup>[m.1]</sup>	8 registers per file
	<a href="#">Real mode</a>	16-bit real mode	<a href="#">real mode code</a>	16 bits	16 bits	8, 16, or 32 bits <sup>[m.1]</sup>	8 registers per file

# Intel x86 Architecture : Overview

# Basic Execution Environment.

## Basic Program Execution Registers

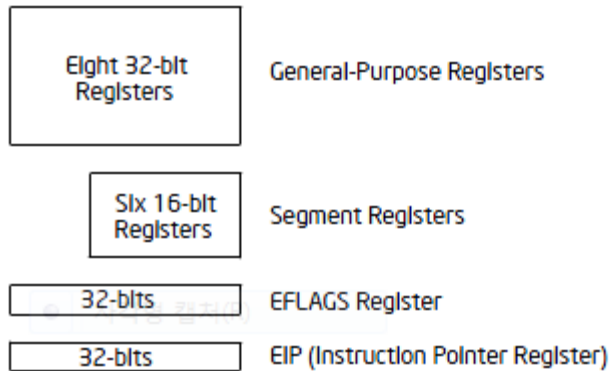

## FPU Registers

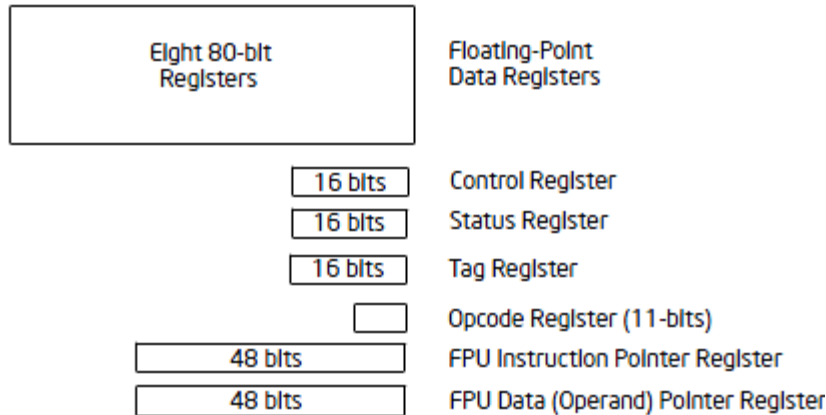

## Memory Management Registers

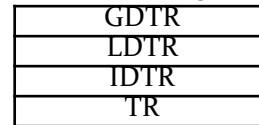

## Control Registers

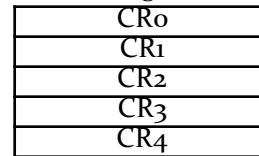

## MMX Registers

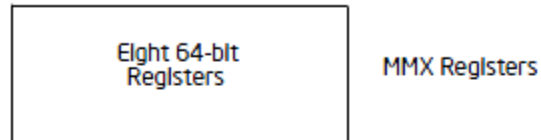

## XMM Registers

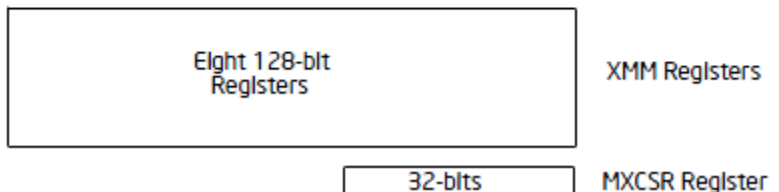

## Debug Registers



## Address Space\*

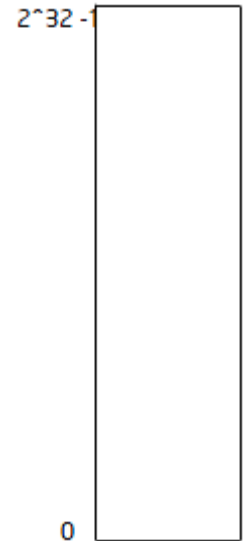

# Operation Mode

- Protected mode
  - This mode is the native state of the processor.
  - Support virtual-8086 mode to execute “real-address mode” 8086 software in a protected, multi-tasking environment.
  - Segmentation, 32bit addressing
- Real mode
  - This mode implements the programming environment of the Intel 8086 processor with extensions (such as the ability to switch to protected or system management mode).
  - The processor is placed in real-address mode following power-up or a reset.
  - 16bit mode, Segmentation, 20bit addressing

# Memory Addresses

- Logical Address
  - Included in the machine language instruction
  - the address of an operand or of an instruction
  - Consists of segment(16bit) and offset(32bit)
    - offset - distance from the start of the segment to the actual address
- Linear Address (known as virtual address)
  - A single 32-bit unsigned integer
  - Range: 0x00000000~0xffffffff(4GB)
- Physical Address
  - Used to address memory cells included in memory chips
  - Represented as 32-bit unsigned integer

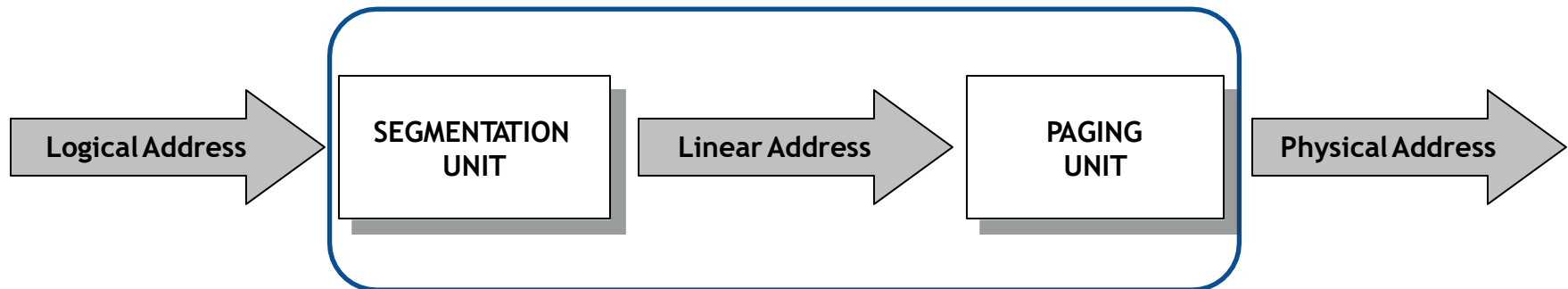

MMU(Memory Management Unit)

# Memory Models

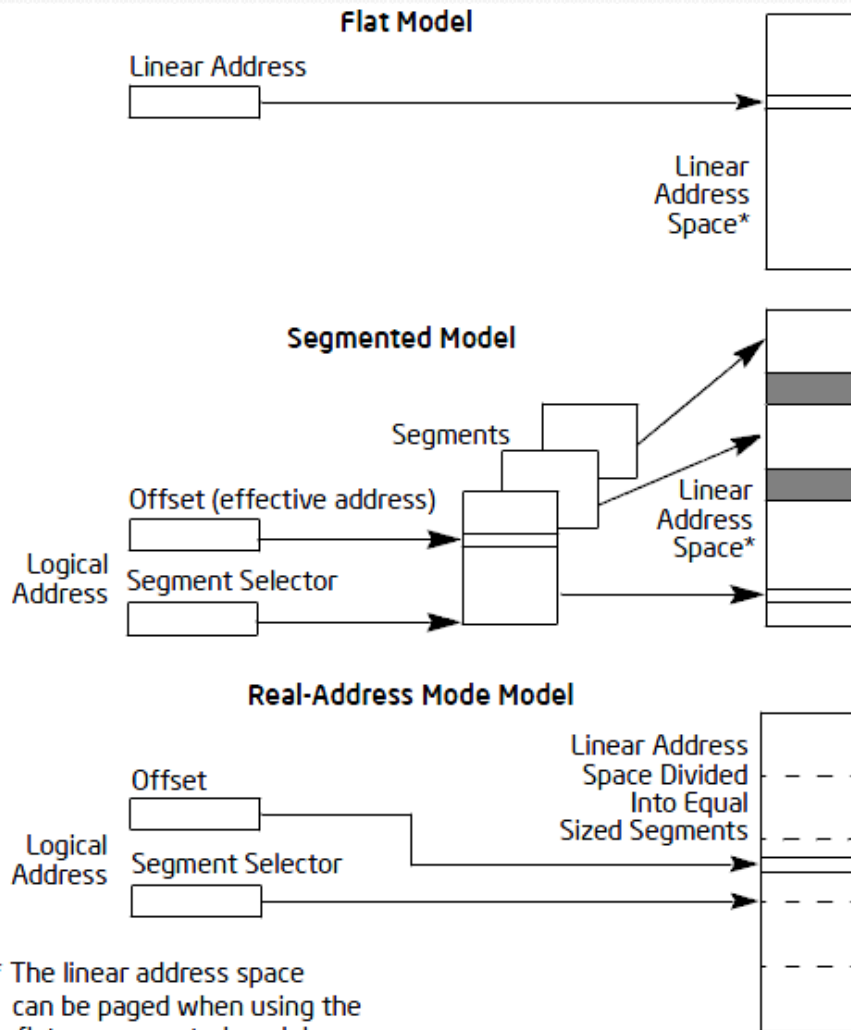

\* The linear address space can be paged when using the flat or segmented model.  
February 23

- No segmentation
- Code, Data, stacks are all contained in this address space.
- 32 bit addressing

- Code, Data, stacks are typically contained in separate segments for better isolation.
- 32 bit addressing (32 bit offset, 16 bit seg. selector)

- Compatibility mode for 8086 processor.
- 20 bit addressing (16 bit offset, 16 seg. selector)



# Privilege Level

- Code modules in lower privilege segments can only access modules operating at higher privilege segments by means of a tightly controlled and protected interface called **gate**.
- Attempts to access higher privilege segments without going through a protection gate and without having sufficient access rights causes a general-protection exception(#GP) to be generated.

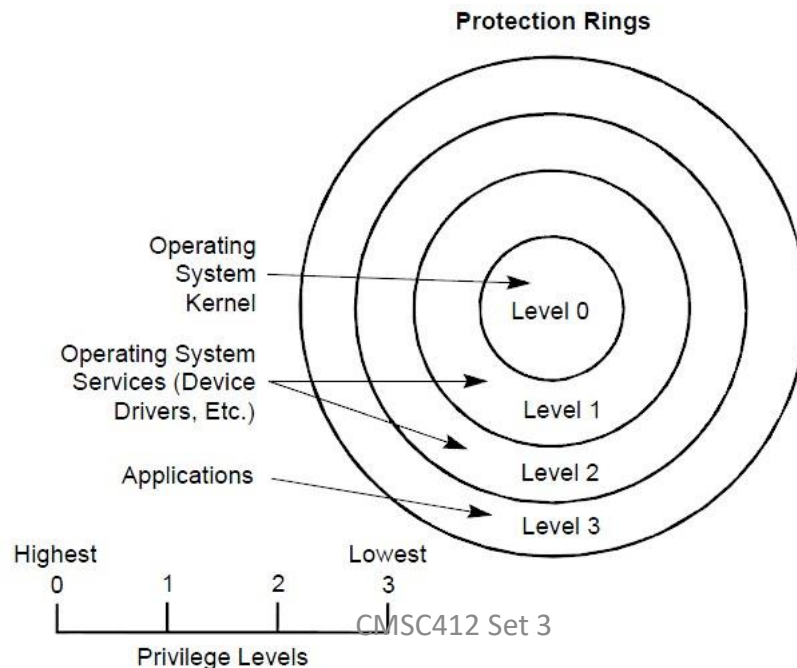

# Intel x86 Architecture : Register

## General Purpose Registers (A, B, C and D)

64	56	48	40	32	24	16	8
R?X							
				E?X			
						?X	
						?H	?L

## Pointer Registers (S and B)

64	56	48	40	32	24	16	8
R?P							
				E?P			
						?P	
							?PL

## Segment Registers

C,D,S,E,F and G

16	8
?S	

Index Registers (S and D)							
64	56	48	40	32	24	16	8
R?I							
				E?I			
						?I	
							?IL

Instruction Pointer Register (I)							
64	56	48	40	32	24	16	8
RIP							
				EIP			
						IP	

# System Level Registers and Data Structures

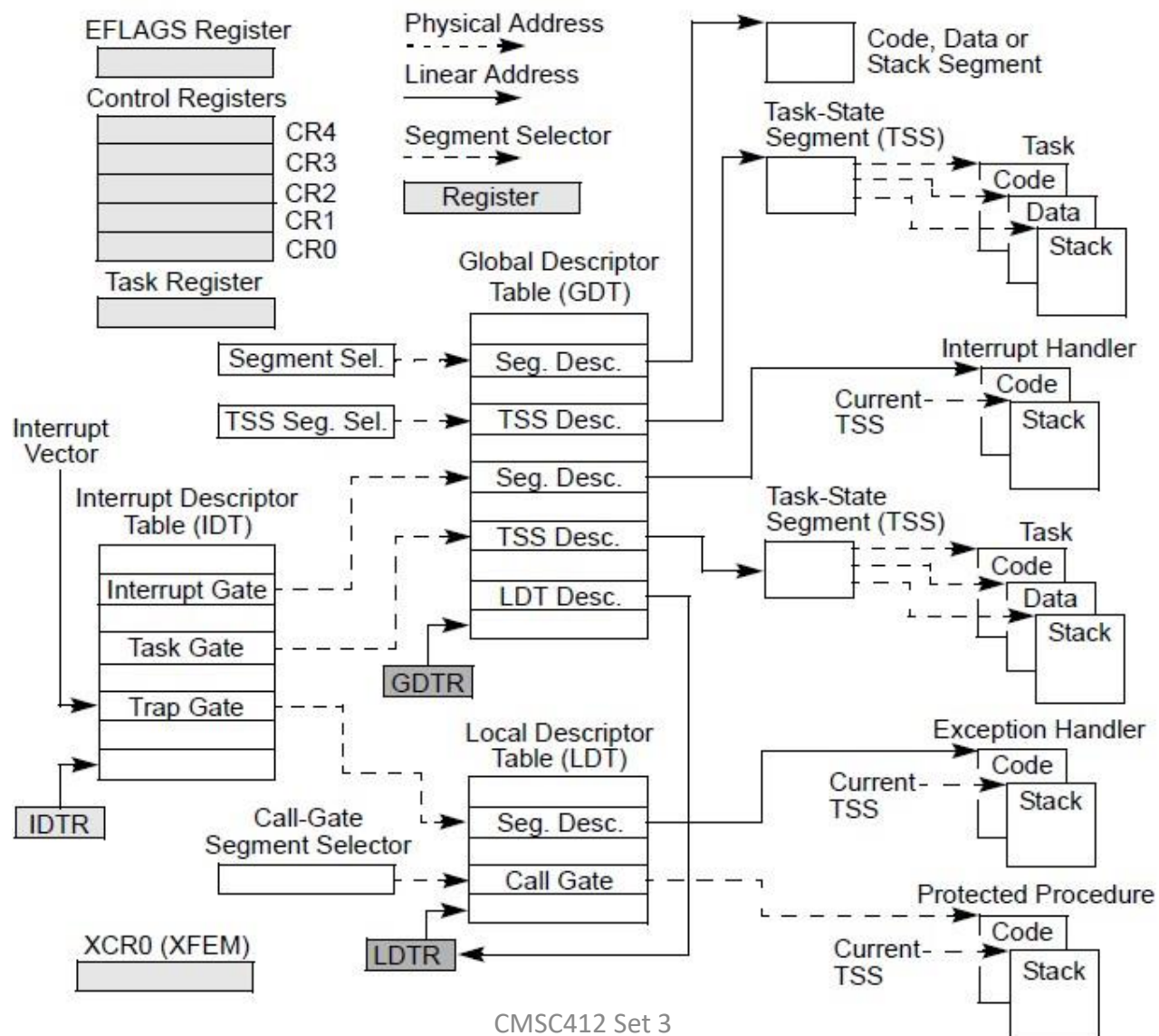

# Basic Program Execution Registers

- General-Purpose Registers
  - For storing operands and pointers
  - ESP – Stack pointer in the SS segment
  - EBP – Frame pointer on the stack
  - ECX – Counter for string and loop operations
  - ESI – Source pointer for string operations
  - EDI – Destination pointer for string operations.

General-Purpose Registers					
31	16 15	8 7	0	16-bit	32-bit
	AH	AL		AX	EAX
	BH	BL		BX	EBX
	CH	CL		CX	ECX
	DH	DL		DX	EDX
	BP				EBP
	SI				ESI
	DI				EDI
	SP				ESP

# Basic Program Execution Registers (cont'd)

- Segment Registers
  - It holds 16-bit **segment selectors**. A segment selector is a special pointer that identifies a segment in memory.
  - To access a particular segment in memory, the segment selector for that segment must be present in the appropriate segment register.

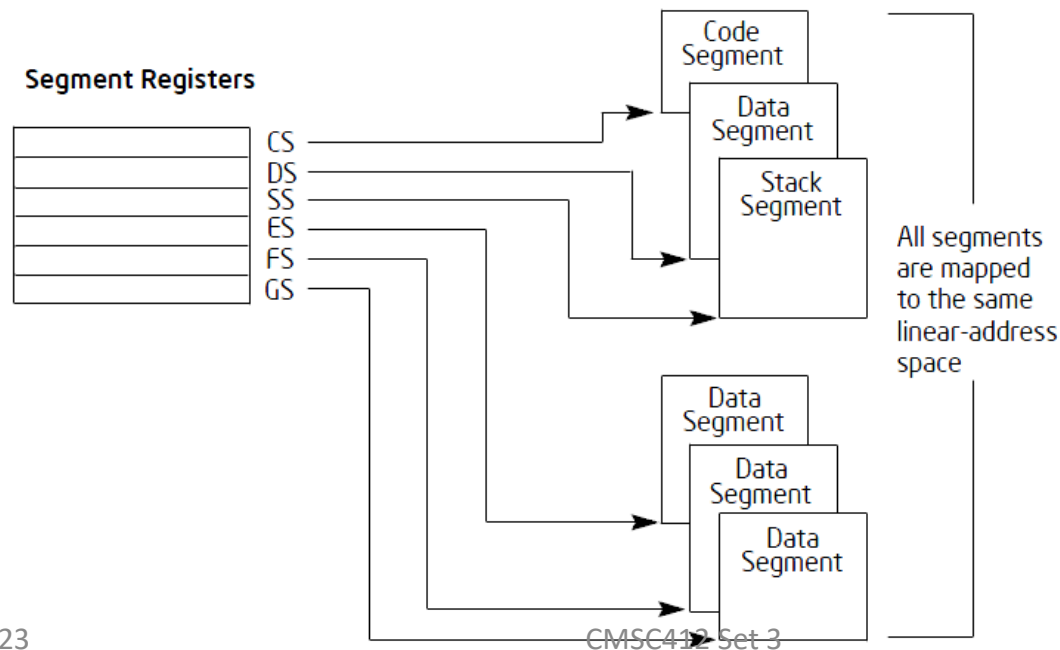

# Basic Program Execution Registers (cont'd)

- Segment Selectors(16bit)
  - Index(13bit) – Segment Descriptor entry in GDT, LDT
  - TI (Table Indicator)(1bit)
    - 0 : Segment Descriptor is stored in GDT
    - 1 : Segment Descriptor is stored in LDT
  - RPL(2bit) – Requested Privilege Level (CPL in CS)

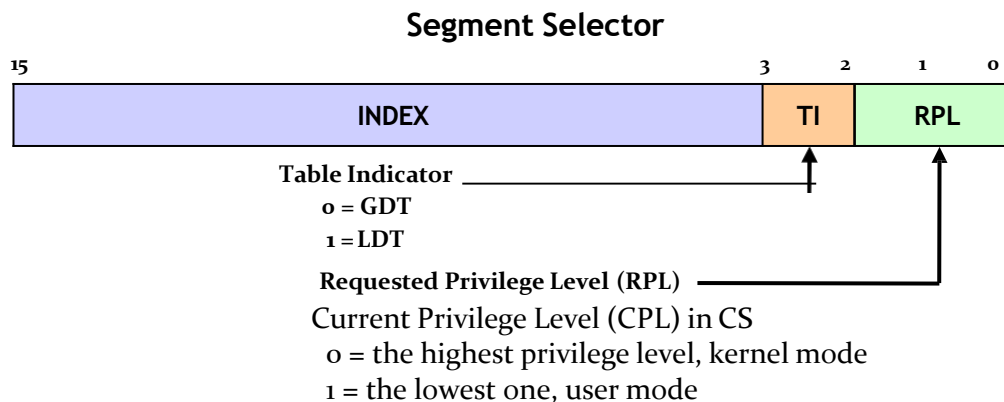



# Basic Program Execution Registers (cont'd)

- Default Segment Selection Rules
  - CS : Instructions
    - All instruction fetches
  - SS : Stack
    - All stack pushes and pops. Any memory reference which uses the ESP or EBP register as a base register.
  - DS : Local Data
    - All data references, except when relative to stack or string destination.
  - ES : Destination Strings
    - Destination of string instructions, eg. MOVS.



# Basic Program Execution Registers (cont'd)

- EIP (Instruction Pointer)
  - The instruction pointer (EIP) register contains the offset in the current code segment for the next instruction to be executed.
  - It is advanced from one instruction boundary to the next in straight-line code or it is moved ahead or backwards by a number of instructions when executing JMP, Jcc, CALL, RET, and IRET instructions.

# Memory Management Registers

- The processor provides four memory-management registers (GDTR, LDTR, IDTR and TR) that specify the locations of the data structures which control segmented memory management. Special instructions are provided for loading and storing these registers.

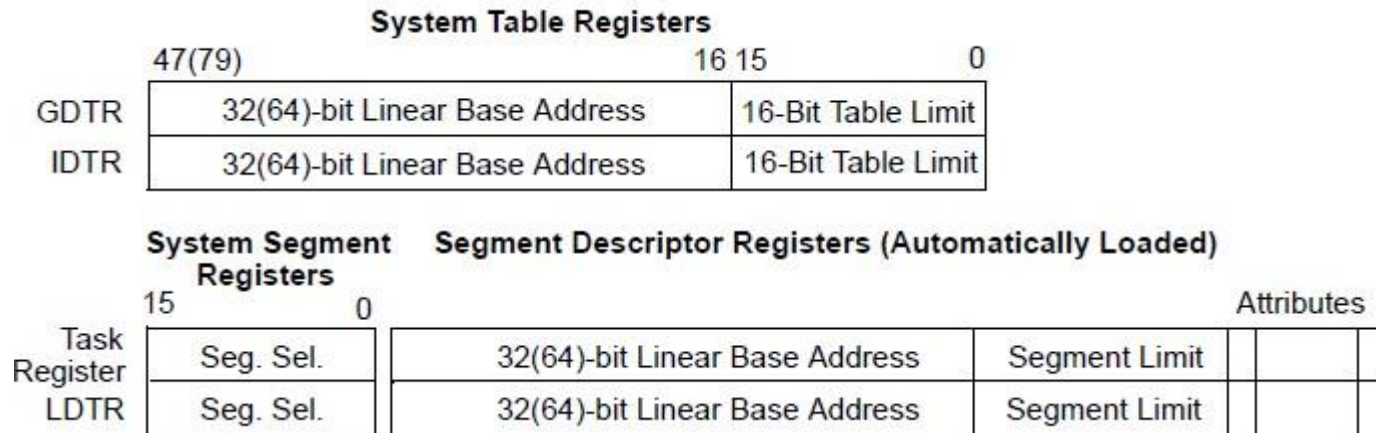

# Control Registers

- Control registers determine operating mode of the processor and the characteristics of the currently running task.

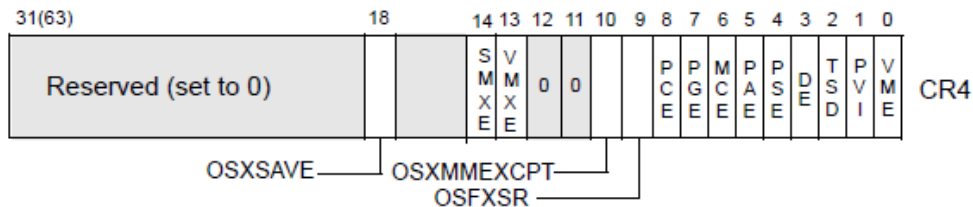

• **CR4**: Contains a group of flags that enable several architectural extensions, and indicate operating system or executive support for specific processor capabilities.

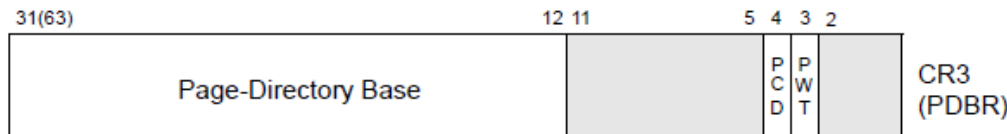

• **CR3**: physical address of the page directory

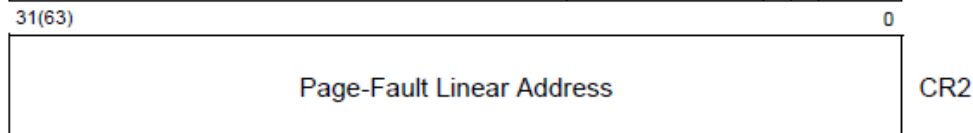

• **CR2**: page fault linear address



• **CR0**: System control flag

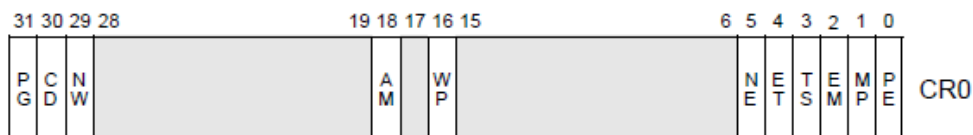

• PE flag

- 0/1 : real mode/protected mode

• PG flag

- 0: linear address == physical address

- 1 : paging enable

• TS flag

- It causes the CPU to trap (int 7) if the floating point unit is used. It is used to restore FPU state lazily after a taskswitch.

# Intel x86 Architecture : Instruction

# General Purpose Instructions

- The general-purpose instructions perform basic data movement, arithmetic, logic, program flow, and string operations that programmers commonly use to write application and system software to run.
  - Data Transfer Instructions
    - MOV, CMOV, PUSH, POP, XCHG, ...
  - Binary Arithmetic Instructions
    - ADD, SUB, INC, DEC, ...
  - Decimal Arithmetic Instructions
  - Logical Instructions
    - AND, OR, XOR, ...
  - Shift and Rotate Instructions
    - SAR, SAL, ROR, ROL, ...
  - Bit and Byte Instructions
    - BT, SET, TEST, ...
  - Control Transfer Instructions
    - JMP, CALL, INT, RET, IRET, INTO, BOUND, ...
  - String Instructions
    - MOVS, LODS, CMPS, ...
  - IO Instructions
    - IN, OUT, ...
  - EFLSGS Control Instructions
    - STC, CLC, ...
  - Segment Register Instructions
    - LDS, LES, LFS, LGS, LSS
  - Misc. Instructions
    - NOP, ...

# System Instructions

- The following system instructions are used to control those functions of the processor that are provided to support operating systems and executives.
  - Manipulate memory management register
    - LGDT, LLDT, LTR, LIDT, SGDT, SLDT, SIDT, STR
  - Load and store control registers
    - MOV {CR0~CR4}, CLI, STI
  - Invalidate Cache and TLB
    - INVD, WBINVD, INVLPG
  - Performance monitoring
    - RDPMC, RDTSC, RDTSCP
  - Fast System Call
    - SYSENTER, SYSEXIT
  - Pointer Validation
    - LAR, LSL, VERR, VERW, ARPL
  - Misc.
    - LOCK, CLTS, HLT

Privileged instructions in red which can be executed only in ring 0.



# Intel x86 Architecture : Memory Management

# Segmentation & Paging

- Segmentation
  - provides a mechanism for dividing the processor's linear address space into smaller protected address spaces called segments.
  - translate logical address to linear address
- Paging
  - provides a mechanism for implementing a conventional demand-paged, virtual-memory system where sections of a program's execution environment are mapped into physical memory as needed. It can also be used to provide isolation between multiple tasks.
  - translate linear address to physical address

# Segmentation & Paging (cont'd)

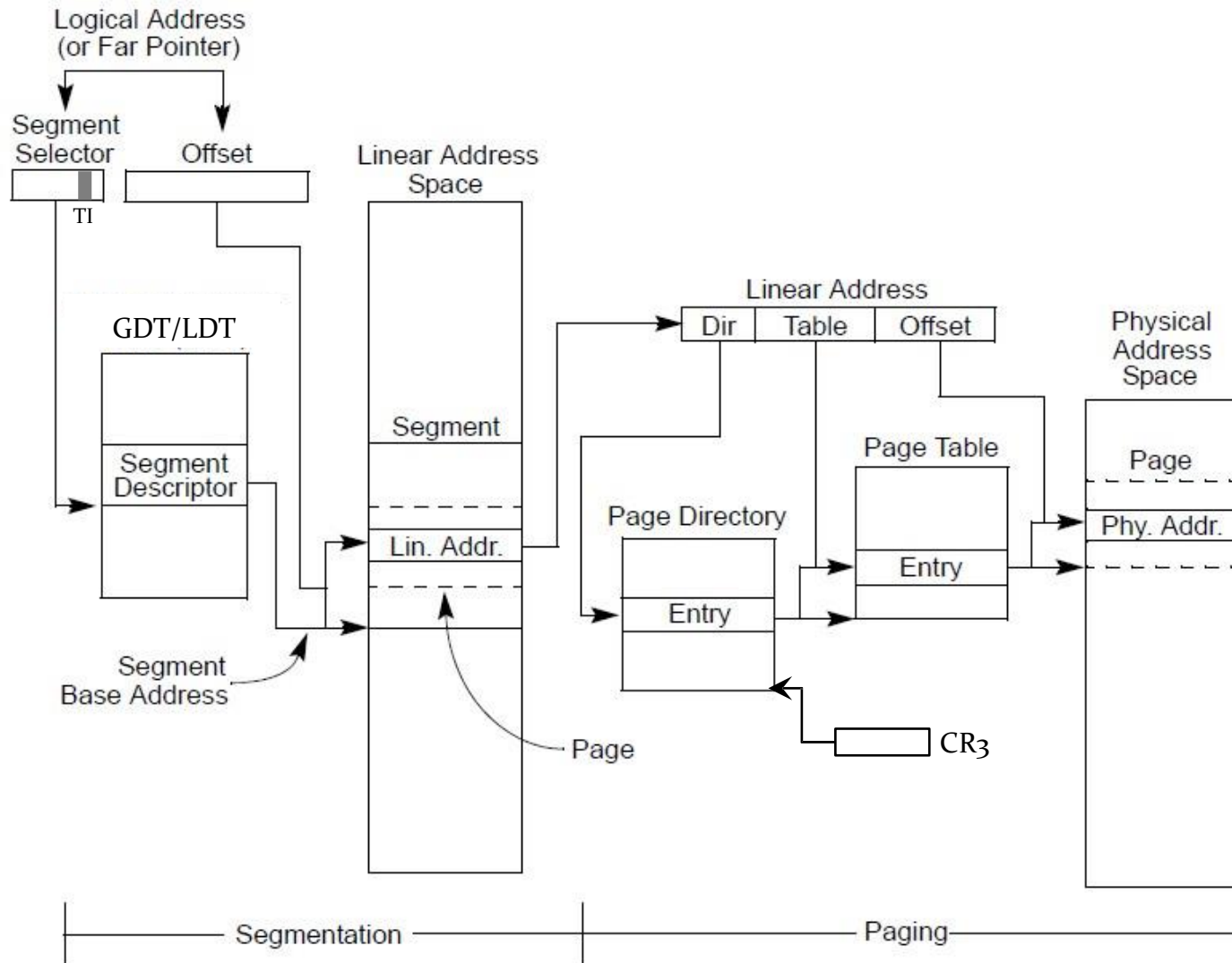

# Segmentation

- Logical address to linear address translation

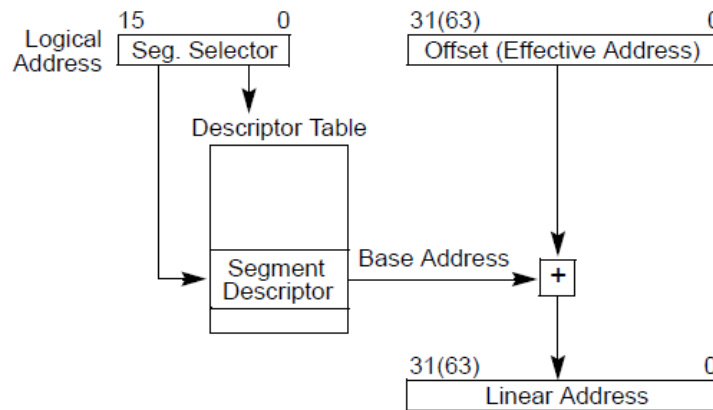

- Segment Selector

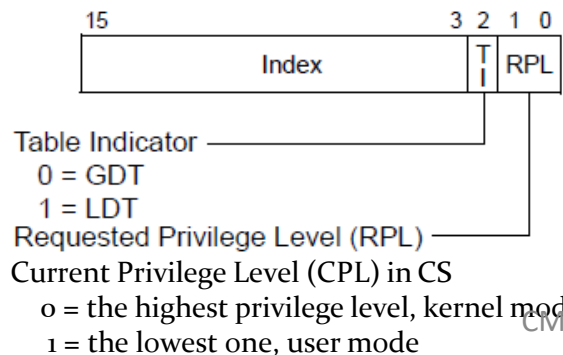

- To reduce address translation time and coding complexity, the processor provides registers for holding up to 6 segment selectors.
- CS, SS, DS, ES, FS, GS

# Segmentation (cont'd)

- Global and local descriptor tables

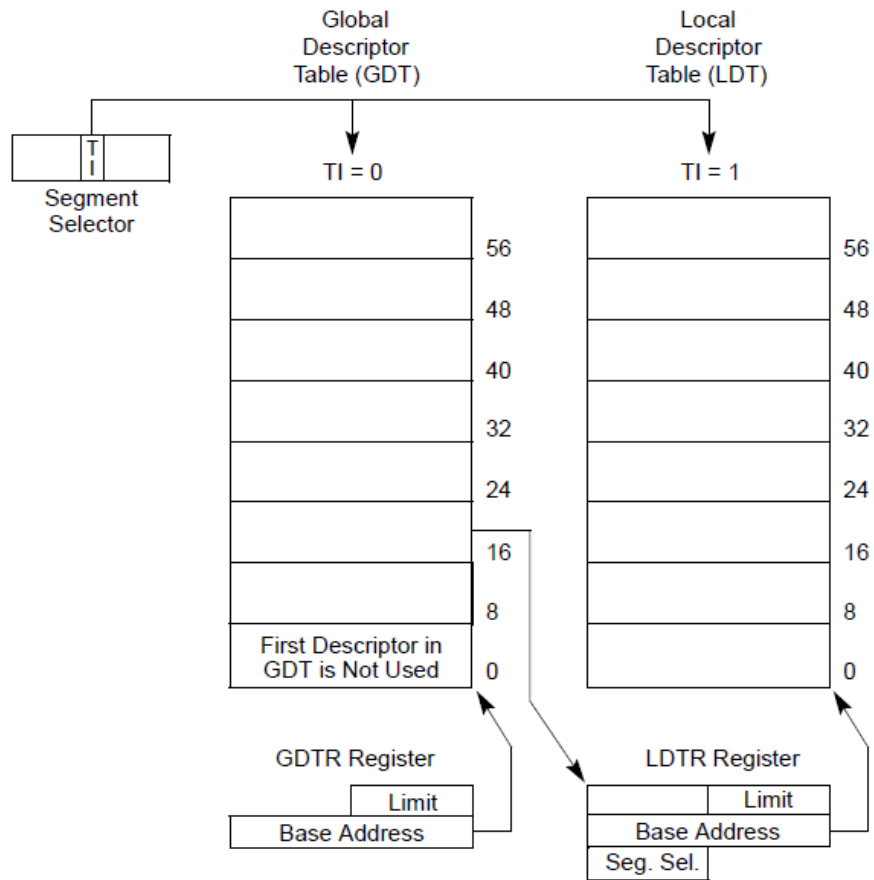

# Segmentation (cont'd)

- Segment Descriptors

- It is a data structure in a GDT or LDT that provides the processor with the size and location of a segment, as well as access control and status information.

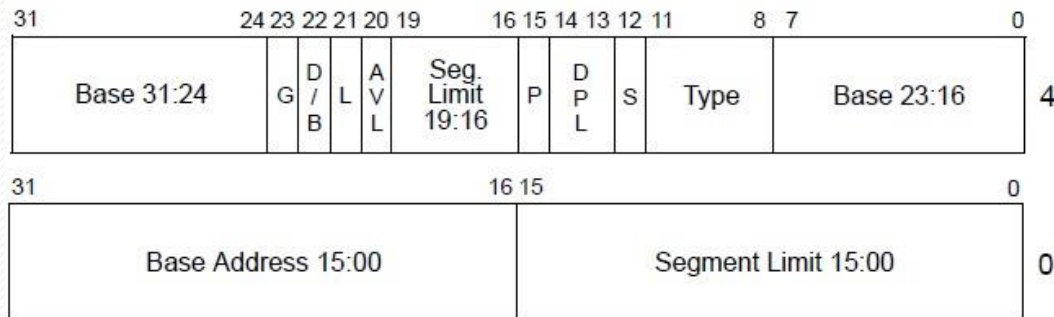

- L — 64-bit code segment (IA-32e mode only)
- AVL — Available for use by system software
- BASE — Segment base address
- ➔ D/B — Default operation size (0 = 16-bit segment; 1 = 32-bit segment)
- ➔ DPL — Descriptor privilege level
- ➔ G — Granularity
- LIMIT — Segment Limit
- ➔ P — Segment present
- S — Descriptor type (0 = system; 1 = code or data)
- TYPE — Segment type

# Paging

- Linear address to physical address translation

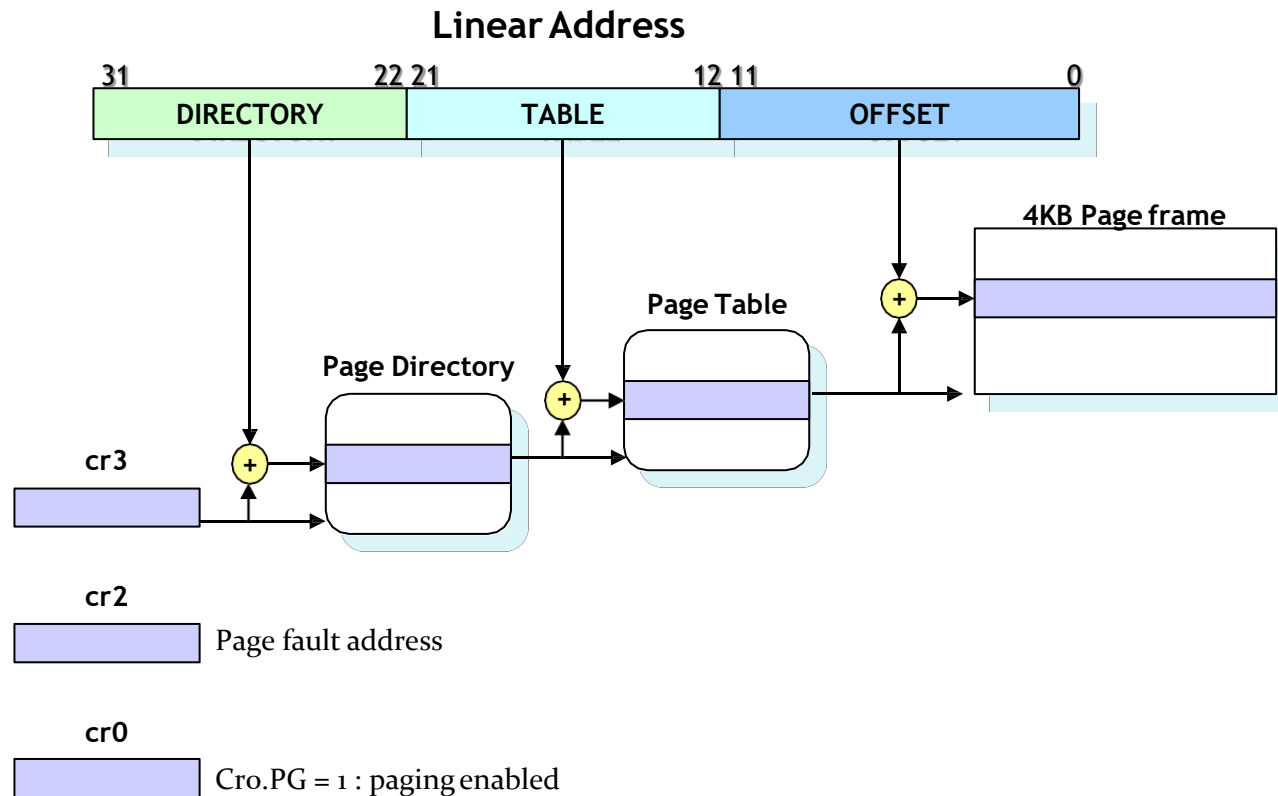

# Paging (cont'd)

- Page Directories and Page Tables entry field
  - Available for system programmer's use
  - Global page
  - Page size(0 indicates 4 Kbytes)
  - Reserved(set to 0) / Dirty
  - Accessed
  - Cache disabled
  - Write-through
  - User/Supervisor
  - Read/Write
  - Present

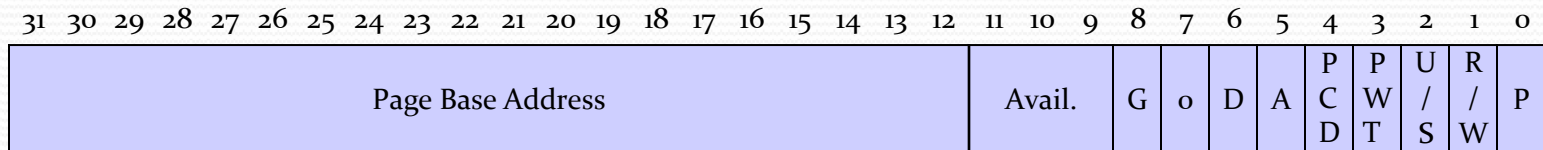
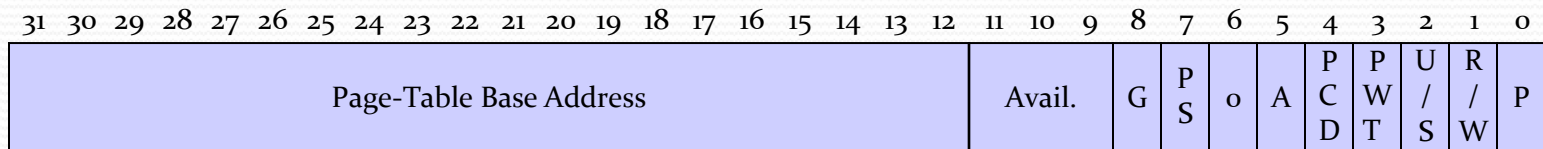



# Protection

- Privilege Level Checking
  - The segment-protection mechanism recognizes 4 privilege levels, numbers from 0 to 3. The greater numbers mean lesser privileges.
  - Privilege levels are checked when the segment selector of a segment descriptor is loaded into a segment register.
  - When the processor detects a privilege level violation, it generates a general-protection exception(#GP).

# Protection (cont'd)

- To carry out privilege-level checks between code segments and data segments, the processor recognizes the following three types of privilege levels:
  - Current Privilege Level (CPL)
    - The privilege level of the currently executing task
    - It is equal to the privilege level of the code segment from which instructions are being fetched.
  - Descriptor Privilege Level (DPL)
    - The privilege level of the segment of gate.
  - Requested Privilege Level (RPL)
    - It is an override privilege level that is assigned to segment selectors.

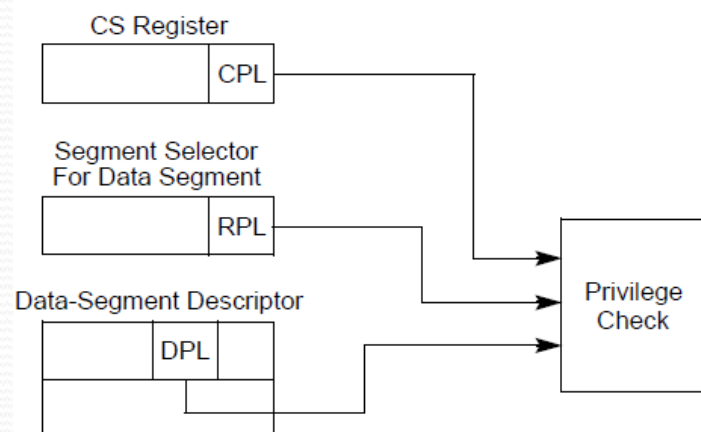

# Intel x86 Architecture : Interrupt and Exception

# Gate

- The architecture also defines a set of special descriptors called **gates** (call gates, interrupt gates, trap gates, and task gates). These provide protected gateways to system procedures and handlers that may operate at a different privilege level than application programs and most procedures.
- For example, a CALL to a call gate can provide access to a procedure in a code segment that is at the same or a numerically lower privilege level (more privileged) than the current code segment. To access a procedure through a call gate, the calling procedure supplies the selector for the call gate. The processor then performs an access rights check on the call gate, comparing the CPL with the privilege level of the call gate and the destination code segment pointed to by the call gate.
- If access to the destination code segment is allowed, the processor gets the segment selector for the destination code segment and an offset into that code segment from the call gate. If the call requires a change in privilege level, the processor also switches to the stack for the targeted privilege level. The segment selector for the new stack is obtained from the TSS for the currently running task. Gates also facilitate transitions between 16-bit and 32-bit code segments, and vice versa.

# Interrupt and Exception handling

- External interrupts, software interrupts and exceptions are handled through the interrupt descriptor table (IDT). The IDT stores a collection of gate descriptors that provide access to interrupt and exception handlers. The linear address for the base of the IDT is contained in the IDT register (IDTR).
- Gate descriptors in the IDT can be interrupt, trap, or task gate descriptors. To access an interrupt or exception handler, the processor first receives an interrupt vector (interrupt number) from internal hardware, an external interrupt controller, or from software by means of an INT, INTO, INT 3, or BOUND instruction.
- The interrupt vector provides an index into the IDT. If the selected gate descriptor is an interrupt gate or a trap gate, the associated handler procedure is accessed in a manner similar to calling a procedure through a call gate. If the descriptor is a task gate, the handler is accessed through a task switch.

# Relationship of the IDTR and IDT

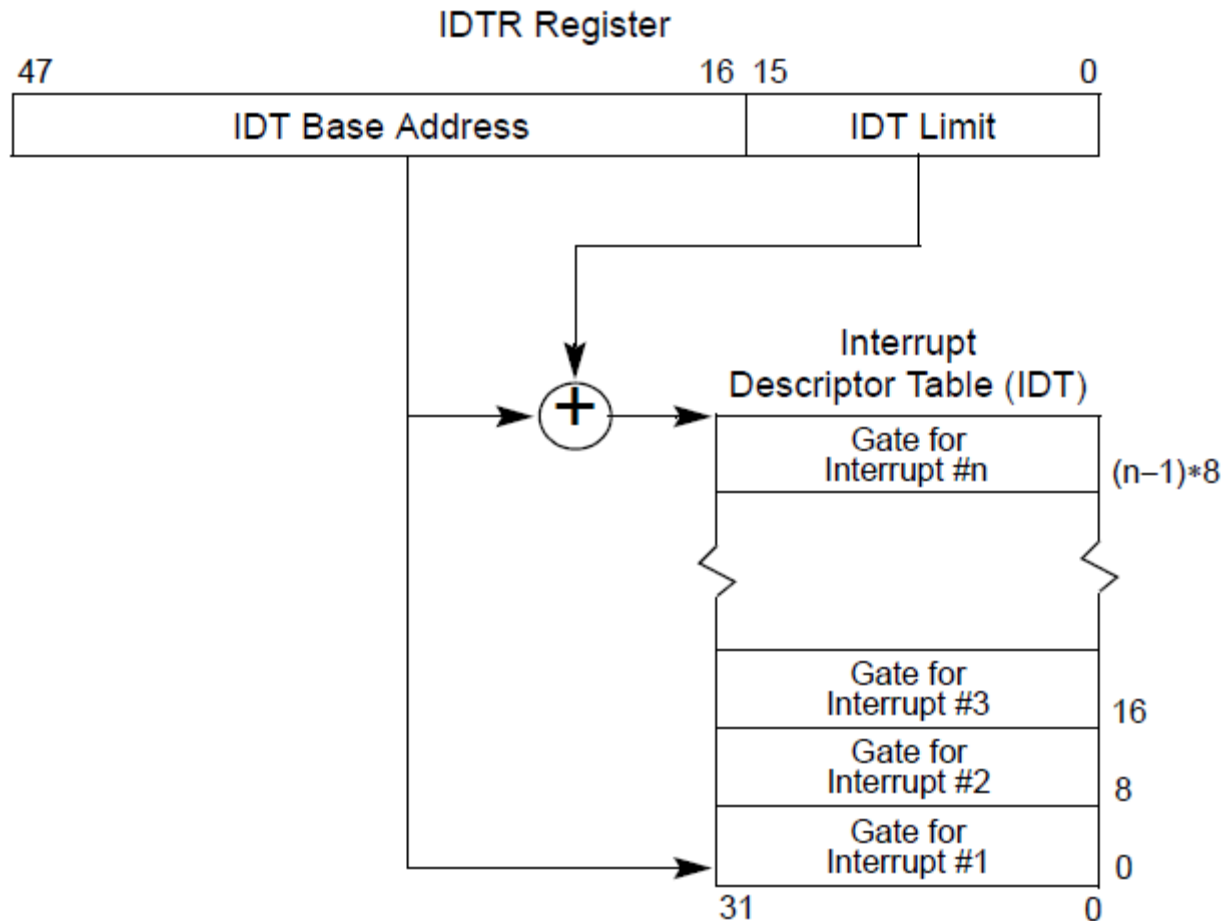

# Gate Descriptor

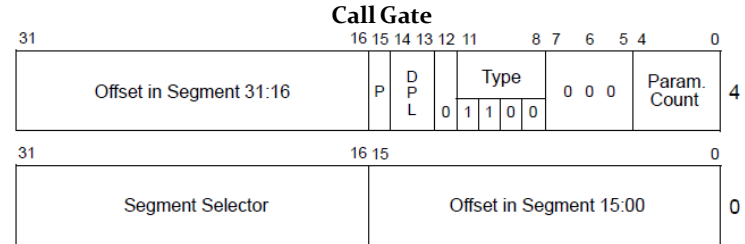
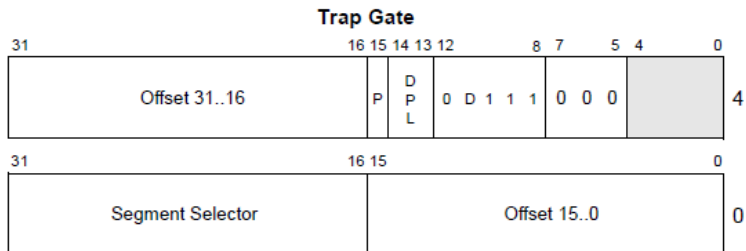
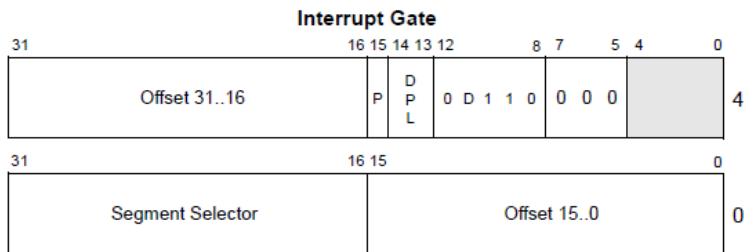
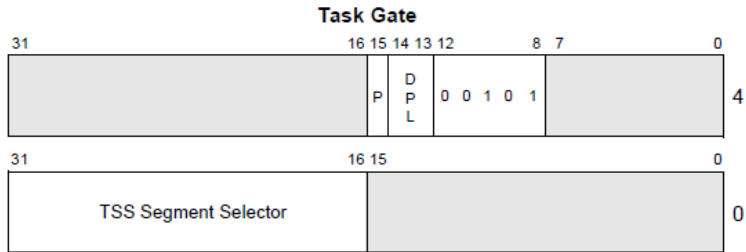

- While transferring control to the proper segment, the processor clears the EFLAGS.IF flag, thus disabling further maskable interrupts.

- While transferring control to the proper segment, the processor does not modify the EFLAGS.IF flag.

- IDT : Task Gate, Interrupt, Trap Gate
- LDT : Call Gate

DPL      Descriptor Privilege Level  
 Offset    Offset to procedure entry point  
 P        Segment Present flag  
 Selector   Segment Selector for destination code segment

Size of gate: 1 = 32 bits; 0 = 16 bits

February 23  
 Reserved

# Executing a handler

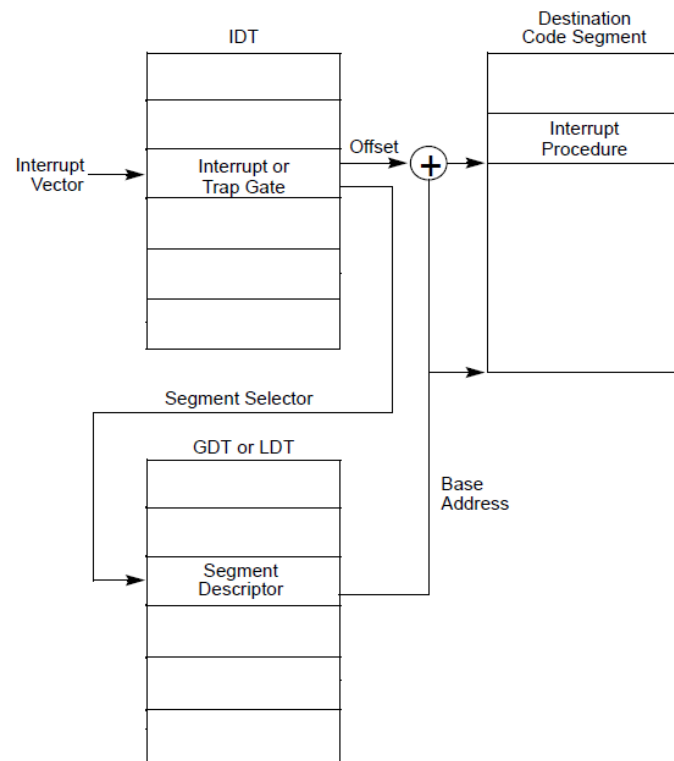

\* Exception or Interrupt Procedure call

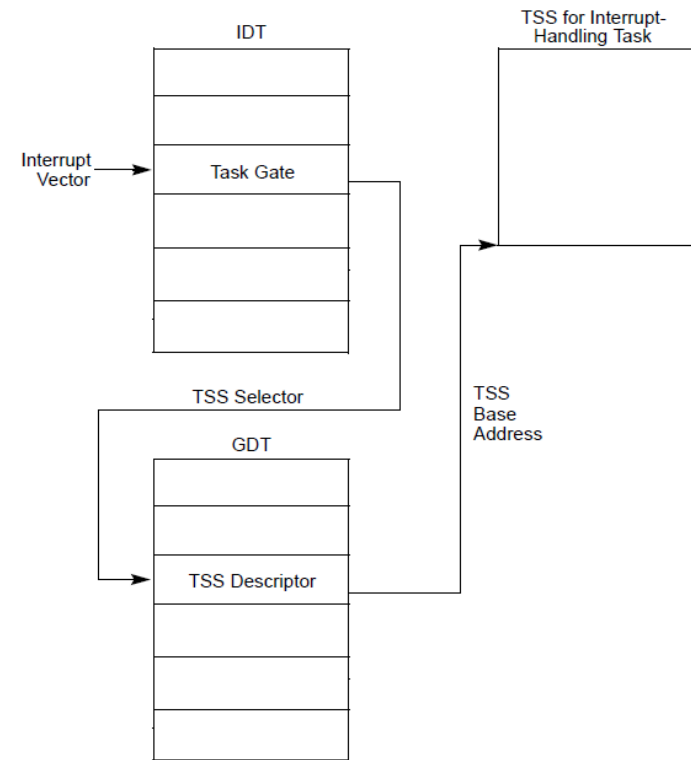

\* Interrupt Task Switch



# Interrupt and Exception Vectors

- 0 ~ 31 (fixed)
  - Exceptions and nonmaskable interrupts
    - 6: Invalid Opcode
    - 13 : general protection exception
    - 14 : page fault
- 32 ~ 47
  - Maskable interrupts
  - Interrupts caused by IRQs
- 48 ~ 255
  - S/W interrupts
  - Linux uses only one of them,
    - 128 : to implement system calls

# Interrupt and Exceptions

- When an interrupt or exception is signaled, the processor halts execution of the current program or task and switches to a handler procedure that has been written specifically to handle the interrupt or exception condition.
- The processor accesses the handler procedure through an entry in the interrupt descriptor table (IDT).
- When the handler has completed handling the interrupt or exception, program control is returned to the interrupted program or task.
- If the code segment for the handler procedure has the same privilege level as the currently executing program or task, the handler procedure uses the current stack; if the handler executes at a more privileged level, the processor switches to the stack for the handler's privilege level.
- A return from an interrupt or exception handler is initiated with the IRET instruction. The IRET instruction is similar to the far RET instruction, except that it also restores the contents of the EFLAGS register for the interrupted procedure.

# Interrupt and Exceptions (cont'd)

- If no stack switch occurs, the processor does the following when calling an interrupt or exception handler
  - Pushes the current contents of the EFLAGS, CS, and EIP registers (in that order) on the stack.
  - Pushes an error code (if appropriate) on the stack.
  - Loads the segment selector for the new code segment and the new instruction pointer (from the interrupt gate or trap gate) into the CS and EIP registers, respectively.
  - If the call is through an interrupt gate, clears the IF flag in the EFLAGS register.
  - Begins execution of the handler procedure.
- When executing a return from an interrupt or exception handler from the same privilege level as the interrupted procedure, the processor performs these actions:
  - Restores the CS and EIP registers to their values prior to the interrupt or exception.
  - Restores the EFLAGS register.
  - Increments the stack pointer appropriately.
  - Resumes execution of the interrupted procedure.

# Interrupt and Exceptions (cont'd)

- If a stack switch does occur, the processor does the following:
  - Temporarily saves (internally) the current contents of the SS, ESP, EFLAGS, CS, and EIP registers.
  - Loads the segment selector and stack pointer for the new stack (that is, the stack for the privilege level being called) from the TSS into the SS and ESP registers and switches to the new stack.
  - Pushes the temporarily saved SS, ESP, EFLAGS, CS, and EIP values for the interrupted procedure's stack onto the new stack.
  - Pushes an error code on the new stack (if appropriate).
  - Loads the segment selector for the new code segment and the new instruction pointer (from the interrupt gate or trap gate) into the CS and EIP registers, respectively.
  - If the call is through an interrupt gate, clears the IF flag in the EFLAGS register.
  - Begins execution of the handler procedure at the new privilege level.
- When executing a return from an interrupt or exception handler from a different privilege level than the interrupted procedure, the processor performs these actions:
  - Performs a privilege check.
  - Restores the CS and EIP registers to their values prior to the interrupt or exception.
  - Restores the EFLAGS register.
  - Restores the SS and ESP registers to their values prior to the interrupt or exception, resulting in a stack switch back to the stack of the interrupted procedure.
  - Resumes execution of the interrupted procedure.

# Interrupt and Exceptions (cont'd)

## Stack Usage with No Privilege-Level Change

Interrupted Procedure's and Handler's Stack

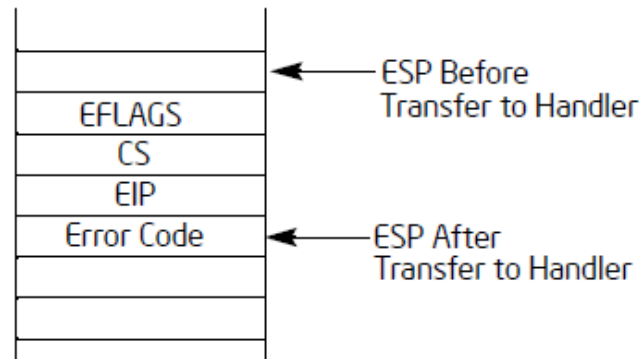

## Stack Usage with Privilege-Level Change

Interrupted Procedure's Stack

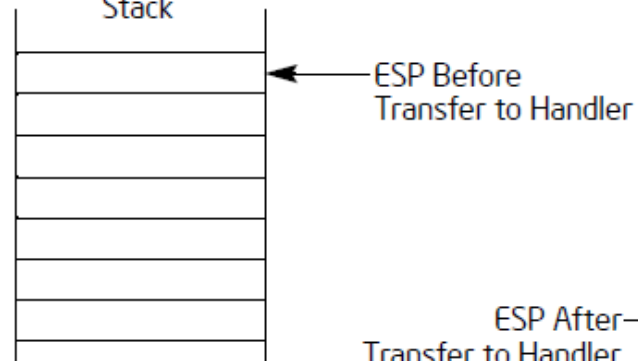

Handler's Stack

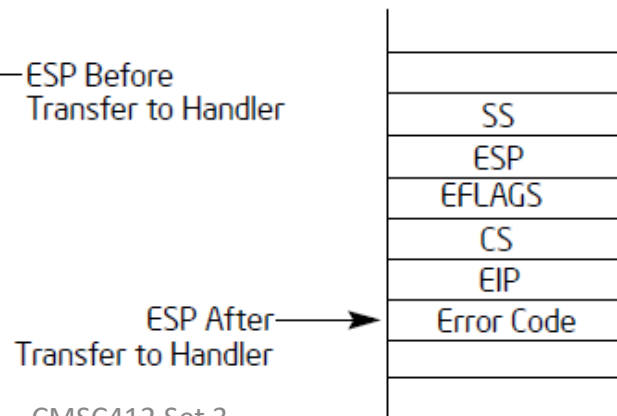

# Intel x86 Architecture : Task Management

# Task Structure

- A task is made up of two parts: a task execution space and a task-state segment(TSS).
- A task is identified by the segment selector for its TSS. When a task is loaded into the processor for execution, the segment selector, base address, limit, and segment descriptor attributes for TSS are loaded into the task register.

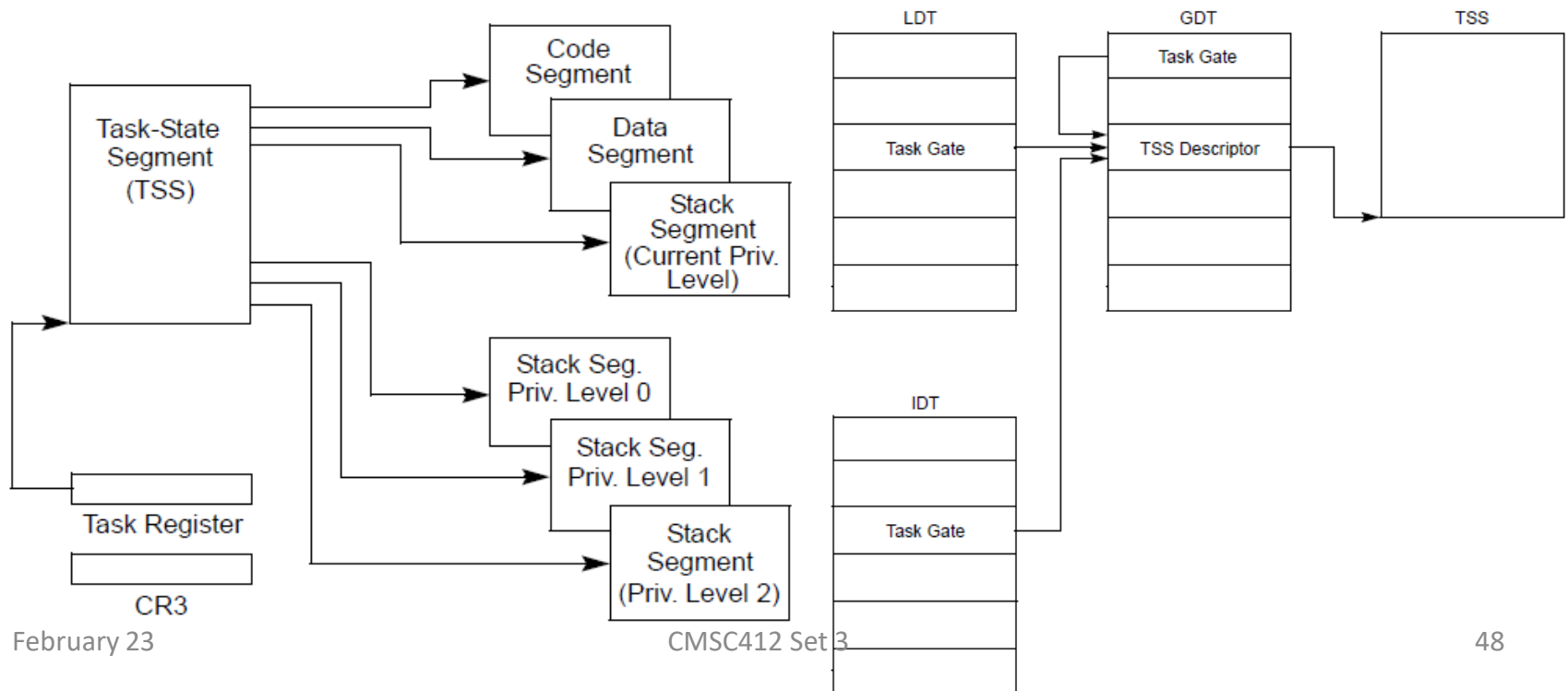

# Task State Segment

31	15	0	
→	I/O Map Base Address	Reserved	T 100
	Reserved	LDT Segment Selector	96
	Reserved	GS	92
	Reserved	FS	88
	Reserved	DS	84
	Reserved	SS	80
	Reserved	CS	76
	Reserved	ES	72
	EDI		68
	ESI		64
	EBP		60
	ESP		56
	EBX		52
	EDX		48
	ECX		44
	EAX		40
	EFLAGS		36
	EIP		32
	CR3 (PDBR)		28
	Reserved	SS2	24
	ESP2		20
	Reserved	SS1	16
	ESP1		12
	Reserved	SS0	8
	ESP0		4
	Reserved	Previous Task Link	0

- SS<sub>0</sub>, SS<sub>1</sub>, SS<sub>2</sub>
  - Stack Segment for ring 0, 1, 2
- ESP<sub>0</sub>, ESP<sub>1</sub>, ESP<sub>2</sub>
  - Stack pointer for ring 0, 1, 2



# H/W Task Switching

- The processor transfers execution to another task in one of following cases
  - JMP or Call instruction to a procedure located in a different task using far pointer
    - to a TSS descriptor in the GDT.
    - to a task-gate descriptor in the GDT or the current LDT.
  - An interrupt or exception vector points to a task-gate descriptor in the IDT.
  - The current task executes an IRET when the NT flag in the EFLAGS register is set.

# H/W Task Switching (cont'd)

- The processor performs the following operations when switching to a new task
  - Obtains the TSS segment selector for the new task.
  - Check that the current (old) task is allowed to switch to the new task. (CPL/DPL/RPL)
  - Saves the state of the current (old) task in the current task's TSS.
  - Loads the task register with the segment selector and descriptor for the new task's TSS.
  - The TSS state is loaded into the processor. This includes the LDTR, CR3, EFLAGS, EIP, the general purpose registers, and the segment selectors.
  - The descriptor associated with the segment selectors are loaded and qualified.

# Intel x86 Architecture : Input/Output

# I/O Port Addressing

- The processor permits applications to access I/O ports in either of two ways:
  - Through a separate I/O address space
    - Handled through a set of I/O instructions and a special I/O protection mechanism
    - Writes to I/O ports are guaranteed to be completed before the next instruction in the instruction stream is executed.
  - Through memory-mapped I/O
    - Accessing I/O ports through memory-mapped I/O is handled with the processor's general-purpose move and string instructions, with protection provided through segmentation or paging.

# I/O Address Space

- The processor's I/O address space is separate and distinct from the physical-memory address space.
- The I/O address space consists of  $2^{16}$  (64K) individually addressable 8-bit I/O ports, numbered 0 through FFFFH.
- I/O port addresses 0F8H through 0FFH are reserved.

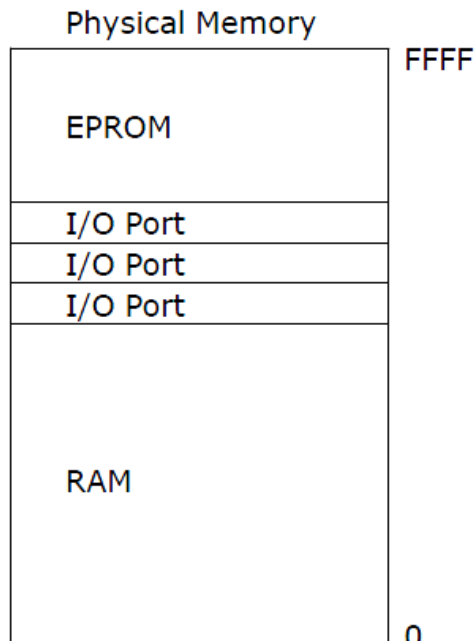

# I/O port protection

- When accessing I/O ports through the I/O address space, two protection devices control access:
  - I/O instructions can be executed only if the current privilege level (CPL) of the program or task currently executing is less than or equal to the IOPL.
  - Any attempt by a less privileged program or task to use an I/O sensitive instruction results in a general-protection exception (#GP) being signaled.
  - The I/O permission bit map in the TSS can be used to modify the effect of the IOPL on I/O sensitive instructions, allowing access to some I/O ports by less privileged programs or tasks.
- When accessing memory-mapped I/O ports,
  - the normal segmentation and paging protection also affect access to I/O ports.

# I/O port protection (cont'd)

- The I/O permission bit map is a device for permitting limited access to I/O ports by less privileged programs or tasks.
  - If in protected mode and the CPL is less than or equal to the current IOPL, the processor allows all I/O operations to proceed.
  - If the CPL is greater than the IOPL, the processor checks the I/O permission bit map to determine if access to a particular I/O port is allowed.
- The I/O permission bit map is located in the TSS for the currently running task or program.
  - Each bit in the map corresponds to an I/O port byte address.

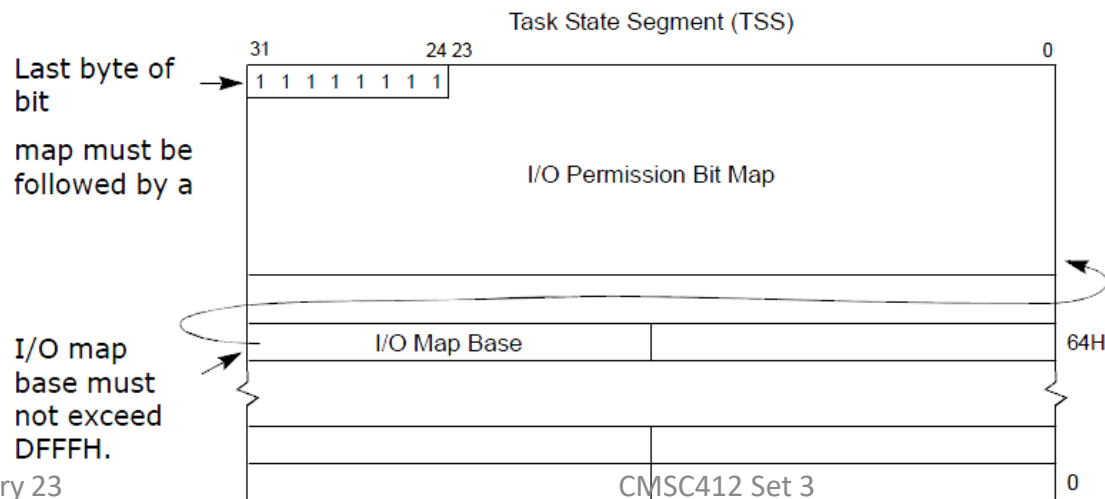

# Intel x86 Architecture : Stack Manipulation



# Stack

- The stack is a contiguous array of memory locations. It is contained in a segment and identified by the segment selector in the SS register.
- Items are placed on the stack using the PUSH instruction and removed from the stack using the POP instruction.
  - When an item is pushed onto the stack, the processor decrements the ESP register, then writes the item at the new top of stack. When an item is popped off the stack, the processor reads the item from the top of stack, then increments the ESP register.
- The processor references the SS register automatically for all stack operations. For example, when the ESP register is used as a memory address, it automatically points to an address in the current stack. Also, the CALL, RET, PUSH, POP, ENTER, and LEAVE instructions all perform operations on the current stack.

# Stack (cont'd)

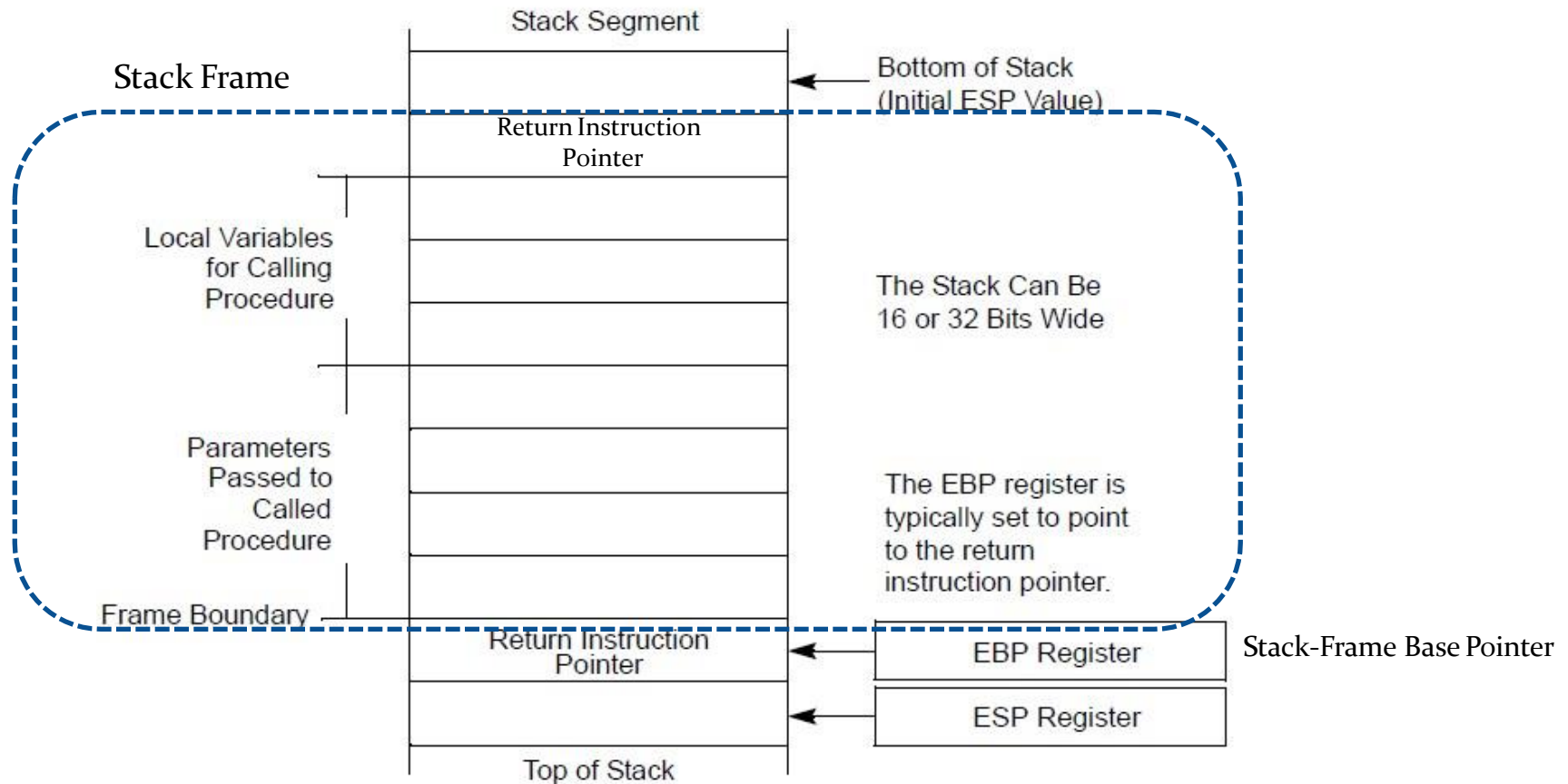

↓ Pushes Move the Top Of Stack to Lower Addresses

↑ Pops Move the Top Of Stack to Higher Addresses

# Procedure Call (CALL/RET)

- When executing a call, the processor does the following
  - Pushes the current value of the EIP register on the stack.
  - Loads the offset of the called procedure in the EIP register.
  - Begins execution of the called procedure.
- When executing a near return, the processor performs these actions:
  - Pops the top-of-stack value (the return instruction pointer) into the EIP register.
  - If the RET instruction has an optional n argument, increments the stack pointer by the number of bytes specified with the n operand to release parameters from the stack.
  - Resumes execution of the calling procedure.

# Procedure Call (CALL/RET) (cont'd)

