



ADONIS[®]

Version 3.9

Volume 3

Method Manual

BPMS Method



Σ

I

N



Δ

A



- Volume 1: Introduction
- Volume 2: User's manual
- Volume 3: Method manual**
- Volume 4: Method definition and administrator's manual
- Volume 5: Installation and Database administrator's manual

BOC Group - addresses:

- Austria: BOC Asset Management GmbH
A-1010 Vienna, Baeckerstrasse 5

BOC Information Technologies Consulting AG
BOC Information Systems GmbH
A-1010 Vienna, Wipplingerstrasse 1

BOC Unternehmensberatung GmbH
A-1010 Vienna, Rabensteig
- Germany: BOC Information Technologies Consulting GmbH
Mosse-Palast am Leipziger Platz
D-10117 Berlin, Vossstrasse 22
- Ibérica: BOC Business Objectives Consulting Ibérica, S.A.
E-28006 Madrid, Calle Velázquez, 71
- Ireland: BOC Information Technologies Consulting Ltd.
Haddington Hall
IRL-Dublin 4, 80 Haddington road
- Greece: BOC Information Technologies Consulting EPE
GR-10680 Athen, Mavromichali 16
- Poland: BOC Information Technologies Consulting Sp. z o.o.
PL-00-679 Warschau, ul. Wilcza 44
- Hotline: hotline@boc-eu.com
- Internet: <http://www.boc-eu.com>
<http://www.boc-us.com>

Table of Contents

Preface	1
1. Using the ADONIS Manuals	3
2. About this Manual	4
2.1 Structure of the Manual	4
2.2 Contents of the Manual	4
3. Note	6
I. ADONIS	7
1. General Notes	9
2. Trademarks	10
II. The ADONIS BPMS method	13
III. Information for ADONIS users	15
1. Model types	16
1.1 Product model	17
1.2 Company map	18
1.3 Business process model	20
1.4 IT system model	24
1.5 Use case diagram	27
1.6 Document model	29
1.7 Working environment model	30
2. Classes	35
2.1 Class "actor"	35
2.2 Class "use case"	37
2.3 Class "system boundary"	39
2.4 Class "Trigger"	41
2.5 Class "Process start"	44
2.6 Class "Subprocess"	51
2.7 Class "Activity"	57
2.8 Class "Decision"	73
2.9 Class "Parallelity"	75
2.10 Class "Merging"	77
2.11 Class "End"	79
2.12 Class "Variable"	82
2.13 Class "Random generator"	84
2.14 Class "Resource" (ADONIS BPMS BP Library 3.9)	87
2.15 Class "Process"	90
2.16 Class "Performance indicator overview"	96
2.17 Class "Performance indicator"	98
2.18 Class "Document"	107
2.19 Class "Note" (ADONIS BPMS BP Library 3.9)	109
2.20 Class "Aggregation" (ADONIS BPMS BP Library 3.9)	113
2.21 Class "Swimlane (horizontal)" (ADONIS BPMS BP Library 3.9)	116
2.22 Class "Swimlane (vertical)" (ADONIS BPMS BP Library 3.9)	119
2.23 Class "External partner"	122
2.24 Class "Product"	123
2.25 Class "Product component"	127
2.26 Class "Application"	130
2.27 Class "Service"	134
2.28 Class "Performance"	137
2.29 Class "Infrastructure element"	140
2.30 Class "Cross-reference"	144
2.31 Class "Organizational unit"	145

Table of Contents

2.32	Class "Performer"	151
2.33	Class "Role"	155
2.34	Class "Position"	156
2.35	Class "Resource" (ADONIS BPMS WE Library 3.9)	158
2.36	Class "Cost center"	160
2.37	Class "Aggregation" (ADONIS BPMS WE Library 3.9)	162
2.38	Class "Note" (ADONIS BPMS WE Library 3.9)	164
2.39	Class "Swimlane (horizontal)" (ADONIS BPMS WE Library 3.9)	167
2.40	Class "Swimlane (vertical)" (ADONIS BPMS WE Library 3.9)	169
3.	Relation classes	172
3.1	Relation class "Subsequent"	172
3.2	Relation class "Sets variable"	176
3.3	Relation class "Sets"	177
3.4	Relation class "Uses"	177
3.5	Relation class "communicates"	178
3.6	Relation class "Value flow"	179
3.7	Relation class "Generalisation"	180
3.8	Relation class "contains"	181
3.9	Relation class "extends"	182
3.10	Relation class "uses"	184
3.11	Relation class "Has process"	185
3.12	Relation class "has Subdocument"	186
3.13	Relation class "has "	186
3.14	Relation class "has"	188
3.15	Relation class "uses "	189
3.16	Relation class "Is dependent on"	191
3.17	Relation class "Owns"	192
3.18	Relation class "has Note" (ADONIS BPMS BP Library 3.9)	193
3.19	Relation class "has Cross-reference"	193
3.20	Relation class "Is subordinated"	194
3.21	Relation class "has Resource"	194
3.22	Relation class "has position"	195
3.23	Relation class "Belongs to"	195
3.24	Relation class "Is manager"	196
3.25	Relation class "Has role"	196
3.26	Relation class "Uses resource"	197
3.27	Relation class "Is charged to"	197
3.28	Relation class "Is cost center manager"	198
3.29	Relation class "has Note" (ADONIS BPMS WE Library 3.9)	198
4.	Predefined queries and relation tables	199
4.1	Analysis component	199
4.1.1	Evaluation of the open questions in company maps	199
4.1.2	Consistency checks on Business Process Models	200
4.1.3	Predefined queries on Business Process Models	202
4.1.4	Evaluation of the open questions in Business Process Models	203
4.1.5	Predefined queries on Working Environment models	204
4.1.6	Evaluation of the open questions in Use Case diagrams	206
4.1.7	Activity-Resource table	207
4.1.8	Activity-Document table	208
4.1.9	Activity-Input document table	208
4.1.10	Activity-Output document table	209
4.1.11	Variable-Activity table	209
4.1.12	Role table	210
4.1.13	Organisational hierarchy table	210
4.2	Evaluation component	211
4.2.1	Process-oriented queries on Business Process Models	211
4.2.2	Activity-oriented queries on Business Process Models	213
4.2.3	Queries on Working Environment models	214
5.	Library specific functions	216
5.1	Acquisition component	216
5.1.1	HOMER scenarios	216

5.2	Modelling component	218
5.2.1	Hierarchical model copy	219
5.2.2	Class cardinality	219
5.2.3	Inter-model references (multiple models)	220
5.2.4	Number objects	222
5.2.5	Reset object numbering	224
5.2.6	Object conversion	224
5.2.7	Display visualised attributes in English/German	225
5.2.7.1	Requirements	226
5.2.7.2	Implementation	228
5.2.8	Monochrome view	230
5.2.9	Display incorrect transition probability	230
5.2.10	Show/hide responsible roles	230
5.2.11	Show/hide reference overview	231
5.2.12	Configure reference overview	231
5.2.13	Change modelling direction	231
5.2.14	Page layout	232
5.2.15	Process Stepper	232
5.2.15.1	Process animation	233
5.2.15.2	Play back process animation	234
5.2.15.3	Additional functions	234
5.3	Simulation component	235
5.3.1	Activation of manual random generator	235
5.3.2	Activation of automatic random generator	236
5.4	Evaluation component	237
5.4.1	Monitoring	237
5.4.1.1	Initialise current values	237
5.4.1.2	Calculate current values	238
5.5	Import-/Export-Component	238
5.5.1	HTML generation	238
5.5.2	Word generation	240
5.5.3	Options (Documentation)	242
5.5.4	Attribute and class filter	247
5.5.5	Corporate Identity (CI)	249
6.	Expressions	250
7.	Attribute profiles	252
8.	Tables	254
9.	Example models	255
9.1	Models of the file Example-General.adl	255
9.1.1	Problem description	256
9.1.2	Modelling in ADONIS	256
9.1.2.1	Company map "Applying for vacation"	256
9.1.2.2	WE Model "Application department"	257
9.1.2.3	BP Model "Application for vacation"	258
9.1.2.4	BP model "Decline application"	261
9.2	Models from the file Example-General_with_resources.adl	262
9.2.1	Problem description	263
9.2.2	Modelling in ADONIS	263
9.2.2.1	Company map "Applying for vacation (resource)"	263
9.2.2.2	WE Model "Application department (resource)"	264
9.2.2.3	BP Model "Application for vacation (resource)"	264
9.2.2.4	BP Model "Decline application (resource)"	266
9.3	Models from the file "example-assurance.adl"	267
9.3.1	Problem description	268
9.3.2	Modelling in ADONIS	268
9.3.2.1	WE Model "Customer service dept."	269
9.3.2.2	BP Model "Contract value enquiries (written)"	271
9.3.2.3	BP Model "Change of address"	273
9.3.2.4	BP Model "Change name of policy holder"	274
9.3.2.5	BP Model "BP change of beneficiary"	275
9.3.2.6	BP Model "SP Dispatch written evaluation"	276

Table of Contents

9.3.2.7	BP Model "SP Policy update"	277
9.3.2.8	Document model "Customer service dept Life Assurance"	277
9.3.2.9	Use case diagrams "Customer database"	278
9.4	Models of the example-bank.adl	279
9.5	Models of the file "Example - Public Sector.adl"	280
9.6	Models of the "example-health.adl"	281
9.7	Models of the file "example-telecommunication.adl"	282
IV.	Information for ADONIS administrators	283
1.	Class attributes	284
1.1	GraphRep	284
1.1.1	Class "actor"	286
1.1.2	Class "use case"	287
1.1.3	Class "system boundary"	288
1.1.4	Class "Trigger"	288
1.1.5	Class "Process start"	292
1.1.6	Class "Subprocess"	296
1.1.7	Class "Activity"	298
1.1.8	Class "Decision"	304
1.1.9	Class "Parallellity"	305
1.1.10	Class "Merging"	306
1.1.11	Class "End"	307
1.1.12	Class "Variable"	308
1.1.13	Class "Random generator"	309
1.1.14	Class "Resource"	310
1.1.15	Class "Process"	313
1.1.16	Class "Performance indicator overview"	315
1.1.17	Class "Performance indicator"	316
1.1.18	Class "Document"	319
1.1.19	Class "Note"	321
1.1.20	Class "Aggregation"	323
1.1.21	Class "Swimlane (horizontal)"	326
1.1.22	Class "Swimlane (vertical)"	336
1.1.23	Class "External partner"	346
1.1.24	Class "Product"	348
1.1.25	Class "Product component"	350
1.1.26	Class "Application"	351
1.1.27	Class "Service"	353
1.1.28	Class "Performance"	355
1.1.29	Class "Infrastructure element"	357
1.1.30	Class "Cross-reference"	358
1.1.31	Class "Organizational unit"	360
1.1.32	Class "Performer"	365
1.1.33	Class "Role"	366
1.1.34	Class "Position"	367
1.1.35	Class "Resource"	368
1.1.36	Class "Cost center"	370
1.1.37	Class "Aggregation"	371
1.1.38	Class "Note"	373
1.1.39	Class "Swimlane (horizontal)"	375
1.1.40	Class "Swimlane (vertical)"	383
1.1.41	Relation class "Subsequent"	391
1.1.42	Relation class "Sets variable"	392
1.1.43	Relation class "Sets"	392
1.1.44	Relation class "Parameter"	393
1.1.45	Relation class "Call parameter"	393
1.1.46	Relation class "Uses"	393
1.1.47	Relation class "communicates"	393
1.1.48	Relation class "Value flow"	394
1.1.49	Relation class "Generalisation"	395
1.1.50	Relation class "contains"	395
1.1.51	Relation class "extends"	396

1.1.52	Relation class "uses".....	396
1.1.53	Relation class "Has process".....	397
1.1.54	Relation class "has Subdocument".....	398
1.1.55	Relation class "has ".....	398
1.1.56	Relation class "has".....	399
1.1.57	Relation class "uses ".....	399
1.1.58	Relation class "Is dependent on".....	400
1.1.59	Relation class "Owns".....	401
1.1.60	Relation class "has Note".....	401
1.1.61	Relation class "has Cross-reference".....	401
1.1.62	Relation class "Is subordinated".....	401
1.1.63	Relation class "has Resource".....	402
1.1.64	Relation class "has position".....	402
1.1.65	Relation class "Belongs to".....	402
1.1.66	Relation class "Is manager".....	402
1.1.67	Relation class "Has role".....	403
1.1.68	Relation class "Uses resource".....	403
1.1.69	Relation class "Is charged to".....	403
1.1.70	Relation class "Is cost center manager".....	403
1.1.71	Relation class "has Note".....	404
1.2	AttrRep.....	404
1.2.1	Class "actor".....	406
1.2.2	Class "use case".....	406
1.2.3	Class "system boundary".....	407
1.2.4	Class "Trigger".....	408
1.2.5	Class "Process start".....	408
1.2.6	Class "Subprocess".....	410
1.2.7	Class "Activity".....	411
1.2.8	Class "Decision".....	415
1.2.9	Class "Parallellity".....	416
1.2.10	Class "Merging".....	417
1.2.11	Class "End".....	417
1.2.12	Class "Variable".....	418
1.2.13	Class "Random generator".....	418
1.2.14	Class "Resource".....	419
1.2.15	Class "Process".....	420
1.2.16	Class "Performance indicator overview".....	421
1.2.17	Class "Performance indicator".....	422
1.2.18	Class "Document".....	424
1.2.19	Class "Note".....	425
1.2.20	Class "Aggregation".....	425
1.2.21	Class "Swimlane (horizontal)".....	426
1.2.22	Class "Swimlane (vertical)".....	427
1.2.23	Class "External partner".....	428
1.2.24	Class "Product".....	428
1.2.25	Class "Product component".....	429
1.2.26	Class "Application".....	430
1.2.27	Class "Service".....	431
1.2.28	Class "Performance".....	432
1.2.29	Class "Infrastructure element".....	433
1.2.30	Class "Cross-reference".....	433
1.2.31	Class "Organizational unit".....	434
1.2.32	Class "Performer".....	436
1.2.33	Class "Role".....	437
1.2.34	Class "Position".....	438
1.2.35	Class "Resource".....	438
1.2.36	Class "Cost center".....	439
1.2.37	Class "Aggregation".....	440
1.2.38	Class "Note".....	441
1.2.39	Class "Swimlane (horizontal)".....	441
1.2.40	Class "Swimlane (vertical)".....	442

Table of Contents

1.2.41	Relation class "Subsequent"	443
1.2.42	Relation class "Parameter"	444
1.2.43	Relation class "Call parameter"	444
1.2.44	Relation class "communicates"	444
1.2.45	Relation class "Value flow"	445
1.2.46	Relation class "Generalisation"	445
1.2.47	Relation class "contains"	446
1.2.48	Relation class "extends"	446
1.2.49	Relation class "uses"	447
1.2.50	Relation class "Has process"	448
1.2.51	Relation class "has "	448
1.2.52	Relation class "has"	449
1.2.53	Relation class "uses "	449
1.2.54	Relation class "Is dependent on"	450
1.2.55	Relation class "Is subordinated"	450
1.3	Model pointer	451
1.3.1	Class "use case"	451
1.3.2	Class "Subprocess"	451
1.3.3	Class "Process"	451
1.3.4	Class "Document"	452
1.3.5	Class "Product"	452
1.3.6	Class "Product component"	452
1.3.7	Class "Application"	452
1.3.8	Class "Service"	452
1.3.9	Class "Performance"	452
1.3.10	Class "Infrastructure element"	452
1.3.11	Class "Cross-reference"	452
1.3.12	Class "Organizational unit"	453
1.4	Class cardinality	453
1.4.1	Class "actor"	454
1.4.2	Class "use case"	456
1.4.3	Class "system boundary"	458
1.4.4	Class "Trigger"	460
1.4.5	Class "Process start"	462
1.4.6	Class "Subprocess"	464
1.4.7	Class "Activity"	467
1.4.8	Class "Decision"	469
1.4.9	Class "Parallellity"	471
1.4.10	Class "Merging"	473
1.4.11	Class "End"	475
1.4.12	Class "Variable"	478
1.4.13	Class "Random generator"	480
1.4.14	Class "Resource"	482
1.4.15	Class "Process"	484
1.4.16	Class "Performance indicator overview"	486
1.4.17	Class "Performance indicator"	488
1.4.18	Class "Document"	490
1.4.19	Class "Note"	493
1.4.20	Class "Aggregation"	495
1.4.21	Class "External partner"	497
1.4.22	Class "Product"	499
1.4.23	Class "Product component"	501
1.4.24	Class "Application"	503
1.4.25	Class "Service"	505
1.4.26	Class "Performance"	507
1.4.27	Class "Infrastructure element"	509
1.4.28	Class "Cost center"	512
1.5	Conversion.....	512
1.5.1	Class "Subprocess"	512
1.5.2	Class "Activity"	513
1.6	Allowed objects.....	513

1.6.1	Class "Swimlane (horizontal)"	514
1.6.2	Class "Swimlane (vertical)"	514
1.6.3	Class "Swimlane (horizontal)"	514
1.6.4	Class "Swimlane (vertical)"	514
2.	Library attributes	515
2.1	Keywords (Description)	516
2.2	Description (Description)	516
2.3	Comment (Description)	516
2.4	Service (Description)	516
2.5	Author (Description)	517
2.6	Creation date (Description)	517
2.7	Last user (Description)	517
2.8	Date last changed (Description)	517
2.9	Modi (Add-ons)	517
2.10	Versioning format (Add-ons)	523
2.11	External coupling (Add-ons)	523
2.12	Default settings (Modeling)	533
2.13	Page layouts (Modeling)	534
2.14	Connector marks - Numbering (Modeling)	534
2.15	Connector marks - Graphical representation (Modeling)	534
2.16	Object arrangement (Modeling)	534
2.17	Relation analysis (Analysis)	536
2.18	Simulation definition - Simtext (Simulation)	537
2.19	Simulation definition - Simmapping (Simulation)	537
2.20	Simulation definition - Sim result mapping (Simulation)	538
2.21	Simulation definition - Variable check (Simulation)	539
2.22	Agent definition (Simulation)	539
2.23	Enterprise time - Days per year (Simulation)	547
2.24	Enterprise time - Hours per day (Simulation)	547
2.25	Activity based costing - CCC mapping (Evaluation)	548
2.26	Activity based costing - CCC default settings (Evaluation)	548
2.27	Dynamic evaluation modules (Evaluation)	548
2.28	Configuration of documentation (Documentation)	548
V.	Index	555

Table of Contents

Preface

Welcome to



the **integrated Business Process and Knowledge Management Toolkit** from the *Management Office* of the BOC Group.

ADONIS offers you a wide range of various functionality in the following operational areas:

E-Business:

E-business application development, as well as constant and integrated modelling of business models, Business Processes, products, IT systems and IT infrastructures.

Business process management:

Acquisition, modelling, analysis, simulation, evaluation, documentation and realisation of Business Processes.

Process-based application development:

Application development with workflow, CASE-, groupware and object technology as well as process-based introduction of standard software.

Process Warehouses:

Operational data management and Evaluation based on business process and integrated solutions with different workflow products.

Knowledge management - Training and Learning:

Production of training aids through graphic models and process-orientated knowledge management.

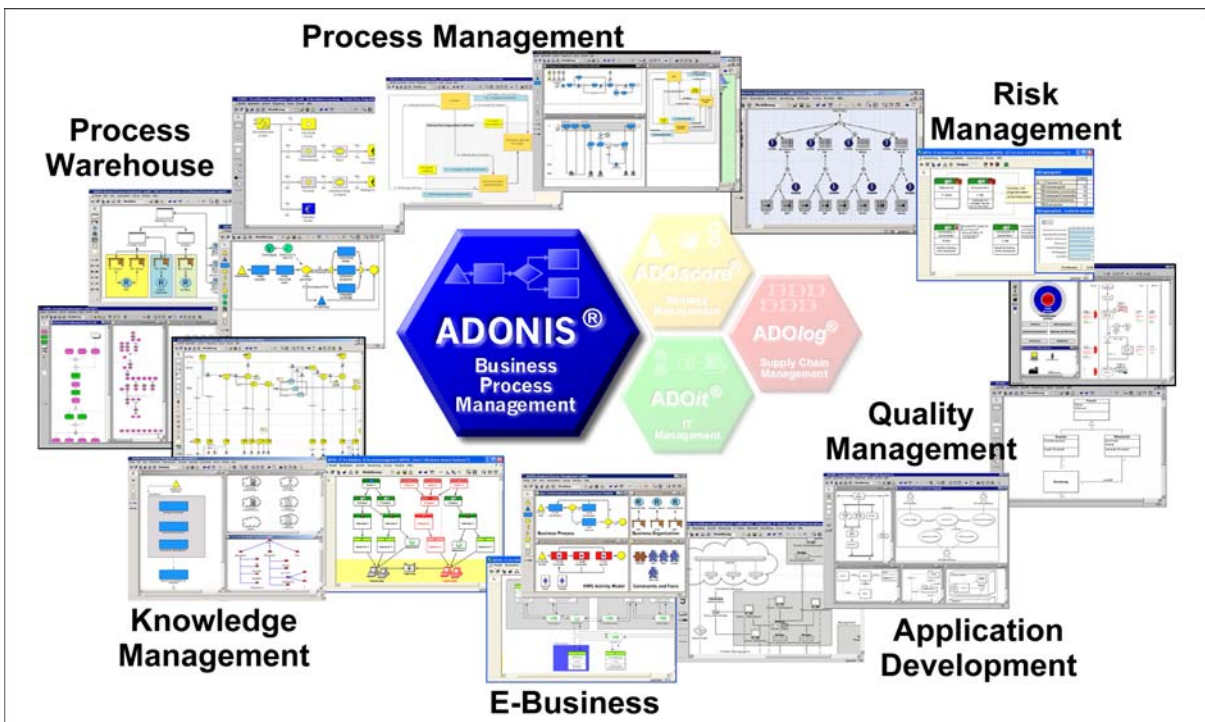

ADONIS is a client/server multi-user system, which has an object-oriented structure. Additionally, **ADONIS** has a remarkable adaptation possibility, so it can be configured according to your needs and developed according to your requirements ("ADONIS-customising").

We hope that our tool meets your requirements and that you have a lot of fun working with ADONIS.

Your BOC Team

Vienna, spring 2006

1. Using the ADONIS Manuals

Three different user groups who use ADONIS can be distinguished:

- **System Administrators**, (in particular **Database Administrators**),
- **ADONIS Administrators** and
- **ADONIS Users**.

System Administrators install ADONIS and create the ADONIS databases. Additionally they can save and restore ADONIS databases. For database administration please refer to ADONIS Database Administration manual.

ADONIS Administrators are responsible for the configuration of ADONIS ("customising"), as well as for the administration of users, libraries, models and components.

ADONIS Users work with the ADONIS Business Process Management Toolkit. They acquire information, model and document their Business Processes and Working Environment (Organisational structures). In addition, the Business Process and Working Environment models constructed can be analysed, simulated, evaluated and if necessary transformed into an operative basis.

If ADONIS is installed as a stand-alone version, one person may carry out all the above roles.

The following ADONIS manuals exist for the different user groups:

- System-Administrators: "**Installation and Database Administration manual**"
- ADONIS-Administrators:
 - **Administration manual**
 - **Method manual**
- ADONIS Users:
 - **Introduction**
 - **User's manual**
 - **Method manual**

2. About this Manual

The following manual describes the installation of ADONIS version 3.9. as well as the ADONIS Database Administration. Using this manual, it will be possible for you to install ADONIS and create an ADONIS database.

The following manual describes the administration of ADONIS version 3.9. Using this manual, it will be possible for you to use the functionality of the ADONIS Administration Toolkit.

The following manual contains an introduction to the ADONIS Business Process Management Toolkit. This introduction provides a brief description of all the functionality within ADONIS. More detailed information can be found in the ADONIS user manual.

The following manual describes the ADONIS Business Process Management Toolkit version 3.9. With the help of this manual, it will be possible for you to use the functionality of the ADONIS Business Process Management Toolkit.

It is assumed, that the user of this manual possesses basic knowledge of the use of graphical operating systems and the handling of the mouse.

2.1 Structure of the Manual

The manual is split into several parts. Each part consists of chapters and subchapters, which are numbered using the Arabic system. A link to a (sub)chapter consists of the number of the corresponding chapter and the corresponding page number.

The title of the actual part is quoted in the headlines of each page. The pages of the manual are continuously in Arabic numerals (the table of contents in roman numerals).

Each picture in the manual is also numbered. Within the manual a reference to any picture will include its number and corresponding page number.

2.2 Contents of the Manual

The installation and database administration manual consists of the following sections:

- ADONIS
- Installation
- Uninstalling
- Database administration
- Appendix

The Administration manual consists of the following sections:

- ADONIS
- General information on the Administration Toolkit
- Administration Toolkit components
- Appendix

The User manual consists of the following sections:

- ADONIS
- Fundamentals of modelling
- General information the Business Process Management Toolkit
- Business Process Management Toolkit components
- Appendix

General hints as well as an overview of ADONIS and its features can be found in the "ADONIS" section.

The "Installation" section provides a description of the installation of ADONIS and the steps that have to be executed after the installation. The "Uninstalling" section contains information on uninstalling ADONIS.

Within the "Database Administration" section, the administration of ADONIS databases is outlined.

The "Appendix" contains additional information on installation and database administration.

The "General Information on the Administration Toolkit" contains general information (regarding components) about the Administration Toolkit like e.g. use elements, ADONIS-Browser, user interface.

The components of the Administration Toolkit (User Management, Library Management, Model Management and Component Management) are described in the "Administration Toolkit" section.

General information on the Administration Toolkit can be found in the "Appendix".

Within the "Fundamentals of modelling" section a background introduction to the (first) modelling of Business Processes is provided.

The "General information on Business Process Management Toolkit" section contains general information (regarding components) about the Business Process Management Toolkit like e.g. elements, ADONIS browser, user interface etc.

The "Business Process Management Toolkit components" describes the components of the Business Process Management Toolkit (acquisition of information, modelling, Analysis, Simulation, Evaluation and Import/Export).

In the "Appendix" general information on the Business Process Management Toolkit can be found.

3. Note

Designation of people within this documentation:

We would like to explicitly state here that wherever the third person singular is used within this manual, this is intended to include female as well as male persons. The use of the male form of description is not intended to be discriminatory in any way but is simply used in order to ensure consistent descriptions.

Pictures within this documentation:

The pictures within this documentation were created using ADONIS 3.9 for Windows 2000 and Windows XP. If you are using different operating system, the appearance of some screens may be slightly different.

ATTENTION: Further publication of this documentation in any form (including copies) is not permitted without the expressed permission of the BOC Group.

Part I

ADONIS

Successful and dynamic enterprises can achieve decisive competitive advantage through the ability to adapt their Business Processes quickly to the rapidly changing market conditions and through the active arrangement of their core competencies. The increasing dynamic, globalisation and increasing competition make efficient Business Process Management an essential goal.

To enable this, the Procedural Modelling, Analysis, Simulation and Evaluation of Business Processes is a decisive success factor. The goals of Business Process Management are the optimisation of both the processes of an enterprise as well as the resources and technology which execute those processes.

The ADONIS Business Process Management Toolkit, which was developed by BOC in co-operation with the University of Vienna offers essential tool support for re-engineering and reorganisation of projects.

ADONIS was specifically designed for the particular needs of financial services organisations and provides functionality primarily for the following application areas:

- Business Process Optimisation / Business Process Re-engineering (BPR)
- Quality Management / ISO 9000 Certification and Maintenance
- Controlling (Process Costing)
- Personnel Management (Personnel and Resource planning)
- Organisation Management (Enterprise documentation, Job descriptions etc.)
- Information Management (Creation of technical concepts for IT systems, Interfaces to Workflow and CASE systems, Introduction of ERP Systems)
- Creation of electronic handbooks which can be made available over an intranet with the use of powerful multi media functionality
- Evaluation of Business Processes (Benchmarking, Monitoring, "Should-be" comparison)

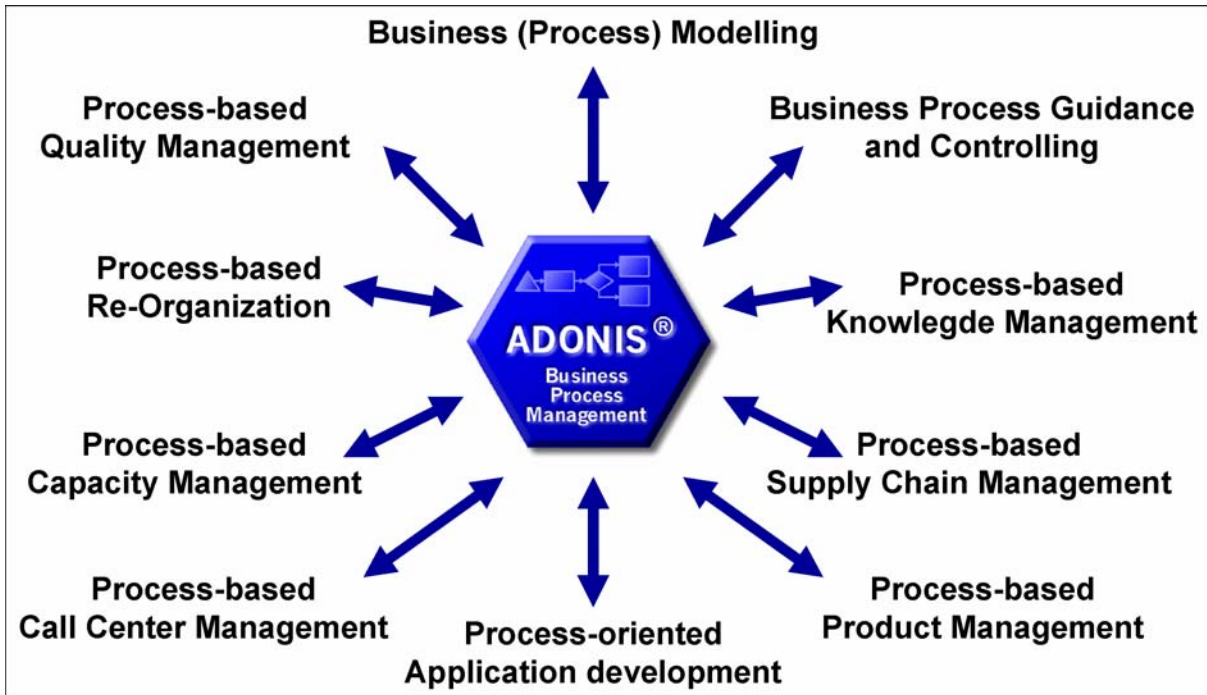

Figure 1: Business Process Management using ADONIS

The "Meta-concept" of ADONIS means that through customising, the tool can be configured to optimally suit the particular requirements of any user. The ADONIS user can decide by himself how he should build the processes and how he can best use the ADONIS mechanisms. As ADONIS is method independent, the management of Business Processes on different levels is guaranteed.

1. General Notes

The use of the ADONIS software is primarily subject to the conditions of the licence agreement. Insofar as not agreed otherwise in the licence agreement, the following terms and conditions for usage of the ADONIS software apply:

The customer is informed that all rights relating to the ADONIS software, in particular the copyright and inclusion of all documents and information supplied in the course of contract negotiation as well as any which are currently pending belong to BOC.

BOC transfers to the customer, the non-exclusive and time restricted right to use the ADONIS software in accordance with the conditions of usage specified in the licence agreement.

"Usage" is the total or partial copying (inputting) of the machine-readable software into the specified machine for the processing of the instructions or data contained therein.

The customer may produce a copy of the ADONIS software for backup purposes only. No BOC copyright notice displayed on the software or in the documentation may be changed, amended, replaced or deleted. Reproduction of the documentation is not permitted; additional copies can be obtained from BOC at the current fee.

A separate licence is required for the usage of the ADONIS software on a machine other than the specified machine, except in instances where the specified machine is out of order; in this case the temporary usage of the software on another machine is permitted. The customer agrees to inform BOC without delay of the serial number and location of the specific machine on which ADONIS has been installed, if requested to do so by BOC.

The customer is not permitted to wholly or partially translate back into source code, reverse engineer or decompile the software.

The customer agrees not to make the ADONIS software, including any copies thereof, available to third parties at any time.

ADONIS is a registered trademark of BOC. Copyright BOC Group 1996-2006. All rights reserved.

All product and companies names (see chap. 2., p. 10) are subject to the copyright law of each company. The usage of product and brand names in this manual may not be construed as permitting third parties free usage of such names in breach of copyright legislation

Hint: The program ADONIS contains some software, which has been developed by the Apache Software Foundation (<http://www.apache.org/>).

As outlined in the terms and conditions of the licence agreement, BOC guarantees the functionality of the software. In so far as not agreed otherwise in the licence agreement, the guarantee period extends six months from the end of the software purchase period.

The liability of BOC is as outlined in the licence agreement. Insofar as legally permitted, BOC will not accept liability for atypical damage, solely financial damage, loss or damage to recorded data, direct or indirect damage, lost profits, expected but unachieved savings or for damages arising from third party claims against the customer.

2. Trademarks

Company

Apache Software Foundation
BOC Asset Management GmbH

Intel Corporation
International Business Machines Corporation

Macrovision Corporation
Microsoft Corporation

microTOOL GmbH

Trademark

Xerces
ADOit,
ADOlog,
ADONIS,
ADOscore,
BPMS,
Management Office
Pentium
DB2,
DB2 Client Application En-
ablers,
DB2 Connect,
DB2 Universal Database,
FlowMark,
Informix,
Lotus Notes,
LOVEM,
MQSeries,
Notes,
OS/2 Warp,
Rational Rose,
WebSphere
InstallShield
BizTalk,
Excel,
Microsoft,
SharePoint,
Visio,
Visual Basic,
Webdings,
Windows,
Windows NT,
Wingdings
case/4/0
objectiF

Oracle Corporation
SAP AG
X/Open Company Limited

Oracle
R/3 System
UNIX

Part II

The ADONIS BPMS method

The ADONIS BPMS method describes a universal modelling technique to model diagrams and organisation charts.

The method is based on the experience and know-how collected by BOC in business process and knowledge management projects and is an industry-neutral methodology for the modelling, documentation and optimisation of business. The available model types (see chap. 2.3, p. 39) enable an integrated and consistent representation of strategy to deployment-relevant information on different levels.

Within this document you will find:

- **Information for ADONIS users**
 - Model types (see chap. 1., p. 16)
 - Classes (see chap. 2., p. 35)
 - Relations (see chap. 3., p. 172)
 - Pre-defined queries and relation tables (see chap. 4., p. 199)
 - Library specific functionality (see chap. 5., p. 216)
 - Example models (see chap. 9., p. 255)
- **Information for ADONIS administrators**
 - Class attributes (see chap. 1., p. 284)
 - Library attributes (see chap. 2., p. 515)

Part III

Information for ADONIS users

Within this part of the method manual you will find an overview of the model types, classes, and relations contained in the ADONIS BPMS application library 3.9. Moreover it should explain which queries and relation tables can be used and which library specific functions are available. An introduction together with example models should make it easier to understand the ADONIS BPMS method library 3.9 and its features.

The areas are:

- Model types (see chap. 1., p. 16)
- Classes (see chap. 2., p. 35)
- Relations (see chap. 3., p. 172)
- Predefined queries and relation tables (see chap. 4., p. 199)
 - Analysis component (see chap. 4.1, p. 199)
 - Evaluation component (see chap. 4.2, p. 211)
- Library-specific functions (see chap. 5., p. 216)
 - Modelling component (see chap. 5.2, p. 218)
 - Simulation component (see chap. 5.3, p. 235)
 - Import-/Export component (see chap. 5.5, p. 238)
 - Example models (see chap. 9., p. 255)
 - Attribute profiles (see chap. 7., p. 252)
- Records (see chap. 8., p. 254)

1. Model types

The dependencies and relationships between the model types are summarized in the figure (see fig. 2) below.

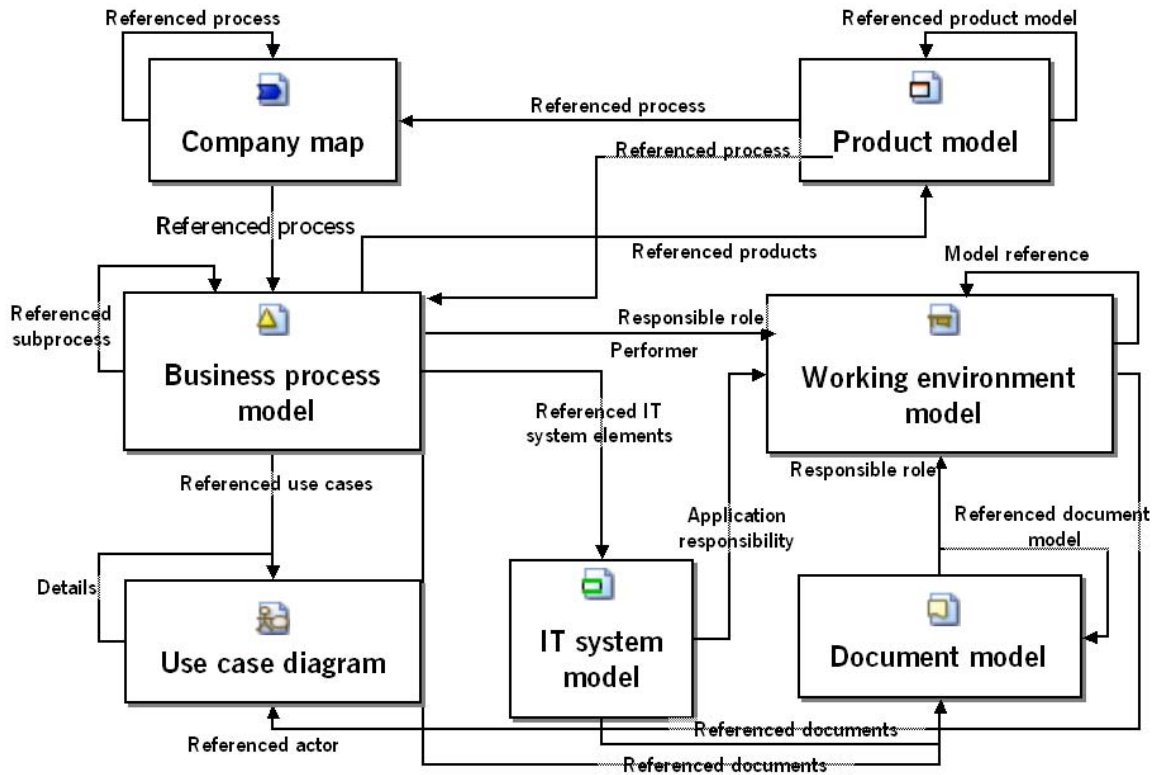









Figure 2: Model type dependencies in the ADONIS BPMS application library

The arrows represent the references between the model types. The arrow label indicates name of attribute that contains a defined reference to the respective model type.









The following modeltypes are defined in the ADONIS BPMS Application Library 3.9:

-  **Product model (see chap. 1.1, p. 17)**
-  **Company map (see chap. 1.2, p. 18)**
-  **Business process model (see chap. 1.3, p. 20)**
-  **IT system model (see chap. 1.4, p. 24)**
-  **Use case diagram (see chap. 1.5, p. 27)**
-  **Document model (see chap. 1.6, p. 29)**
-  **Working environment model (see chap. 1.7, p. 30)**





1.1 Product model

In the Product model an overview of products and products components can be build. Product models can be build hierarchically using products sub models to e.g. illustrate a detailed structure of a product.

Product models offer the following classes:

-  **Product (see chap. 2.24, p. 123)**
-  **Product component (see chap. 2.25, p. 127)**
-  **Note (see chap. 2.19, p. 109)**
-  **Aggregation (see chap. 2.20, p. 113)**
-  **Swimlane (vertical) (see chap. 2.22, p. 119)**
-  **Swimlane (horizontal) (see chap. 2.21, p. 116)**
-  **Cross-reference (see chap. 2.30, p. 144)**
-  **Performance indicator (see chap. 2.17, p. 98)**
-  **Performance indicator overview (see chap. 2.16, p. 96)**

Product models offer the following relation classes:

-  **has (see chap. 3.13, p. 186)**
-  **has Note (see chap. 3.18, p. 193)**
-  **has Cross-reference (see chap. 3.19, p. 193)**
-  **Owns (see chap. 3.17, p. 192)**

The following modes are defined for **Product models**:

- **Standard**

with the following classes:

- Product
- Product component
- Note
- Aggregation
- Swimlane (vertical)
- Swimlane (horizontal)
- Cross-reference

and the following relation classes:

- has
- has Note
- has Cross-reference

- **Standard - including Performance indicators**

with the following classes:

- Product
- Product component
- Performance indicator
- Performance indicator overview
- Note
- Aggregation
- Swimlane (vertical)
- Swimlane (horizontal)
- Cross-reference











and the following relation classes:

- has
- Owns
- has Note
- has Cross-reference





1.2 Company map

Company maps are used to model an overview of Business Process Models (see chap. 1.3, p. 20) or other company maps. Therefore a company map can be seen as a navigation help and entry point into the hierarchy of your Business Process Models.

Company maps offer the following classes:

-  **Process (see chap. 2.15, p. 90)**
-  **Performance (see chap. 2.28, p. 137)**
-  **actor (see chap. 2.1, p. 35)**
-  **External partner (see chap. 2.23, p. 122)**
-  **Aggregation (see chap. 2.20, p. 113)**
-  **Note (see chap. 2.19, p. 109)**
-  **Swimlane (vertical) (see chap. 2.22, p. 119)**
-  **Swimlane (horizontal) (see chap. 2.21, p. 116)**
-  **Cross-reference (see chap. 2.30, p. 144)**
-  **Performance indicator overview (see chap. 2.16, p. 96)**
-  **Performance indicator (see chap. 2.17, p. 98)**

Company maps offer the following relation classes:

-  **Has process (see chap. 3.11, p. 185)**
-  **has Note (see chap. 3.18, p. 193)**
-  **Value flow (see chap. 3.6, p. 179)**
-  **has Cross-reference (see chap. 3.19, p. 193)**
-  **Owns (see chap. 3.17, p. 192)**

The following modes are defined for **Company maps**:

- **Standard**

with the following classes:

- Process
- Performance
- actor
- External partner
- Aggregation
- Note
- Swimlane (vertical)
- Swimlane (horizontal)
- Cross-reference

and the following relation classes:

- Has process
- has Note
- Value flow
- has Cross-reference

- **Standard - including Performance indicators**

with the following classes:

- Process
- Performance
- actor
- External partner
- Aggregation
- Note
- Swimlane (vertical)
- Swimlane (horizontal)
- Cross-reference
- Performance indicator overview
- Performance indicator

and the following relation classes:

Part III

- Has process
- has Note
- Value flow
- has Cross-reference
- Owns

- **All modeling objects**

with the following classes:

- Process
- Performance
- actor
- External partner
- Aggregation
- Note
- Swimlane (vertical)
- Swimlane (horizontal)
- Cross-reference
- Performance indicator overview
- Performance indicator





and the following relation classes:













- Has process
- has Note
- Value flow
- has Cross-reference
- Owns

1.3 Business process model







Business Process Models represent process flows in an organisation. In Business Process Models the sequence of tasks is modelled with use of activities that are needed to resolve a specific task (process). The control objects (Process start, Decision, Parallelism, Merging and End) and the Subsequent relation enable to clearly map the tasks and the process as it happens in the real world (Order, Alternatives, Parallelisms).

Business process models offer the following classes:

-  **Swimlane (horizontal) (see chap. 2.21, p. 116)**
-  **Swimlane (vertical) (see chap. 2.22, p. 119)**
-  **Trigger (see chap. 2.4, p. 41)**
-  **Process start (see chap. 2.5, p. 44)**
-  **Subprocess (see chap. 2.6, p. 51)**

-  **Activity** (see chap. 2.7, p. 57)
-  **Decision** (see chap. 2.8, p. 73)
-  **Parallelity** (see chap. 2.9, p. 75)
-  **Merging** (see chap. 2.10, p. 77)
-  **End** (see chap. 2.11, p. 79)
-  **Note** (see chap. 2.19, p. 109)
-  **Aggregation** (see chap. 2.20, p. 113)
-  **Cross-reference** (see chap. 2.30, p. 144)
-  **Variable** (see chap. 2.12, p. 82)
-  **Random generator** (see chap. 2.13, p. 84)
-  **Resource** (see chap. 2.14, p. 87)
-  **Performance indicator overview** (see chap. 2.16, p. 96)
-  **Performance indicator** (see chap. 2.17, p. 98)

Business process models offer the following relation classes:

-  **Subsequent** (see chap. 3.1, p. 172)
-  **has Note** (see chap. 3.18, p. 193)
-  **has Cross-reference** (see chap. 3.19, p. 193)
-  **Owns** (see chap. 3.17, p. 192)
-  **Sets variable** (see chap. 3.2, p. 176)
-  **Sets** (see chap. 3.3, p. 177)
-  **Uses** (see chap. 3.4, p. 177)

The following modes are defined for **Business process models**:

- **Flow**
with the following classes:
 - Swimlane (horizontal)
 - Swimlane (vertical)
 - Trigger
 - Process start
 - Subprocess
 - Activity
 - Decision
 - Parallelity
 - Merging
 - End

Part III

- Note
- Aggregation
- Cross-reference

and the following relation classes:

- Subsequent
- has Note
- has Cross-reference
- Owns

- **Flow - including Variables and Random generators**

with the following classes:

- Swimlane (horizontal)
- Swimlane (vertical)
- Trigger
- Process start
- Subprocess
- Activity
- Decision
- Parallellity
- Merging
- End
- Note
- Aggregation
- Cross-reference
- Variable
- Random generator

and the following relation classes:

- Subsequent
- has Note
- has Cross-reference
- Owns
- Sets variable
- Sets

- **Flow - including Resources**

with the following classes:

- Swimlane (horizontal)
- Swimlane (vertical)
- Trigger
- Process start

- Subprocess
- Activity
- Decision
- Parallellity
- Merging
- End
- Note
- Aggregation
- Cross-reference
- Resource

and the following relation classes:

- Subsequent
- has Note
- has Cross-reference
- Owns
- Uses

- **Flow - including Performance indicators**

with the following classes:

- Swimlane (horizontal)
- Swimlane (vertical)
- Trigger
- Process start
- Subprocess
- Activity
- Decision
- Parallellity
- Merging
- End
- Note
- Aggregation
- Cross-reference
- Performance indicator overview
- Performance indicator

and the following relation classes:

- Subsequent
- has Note
- has Cross-reference
- Owns

- **All modelling objects**

with the following classes:

- Swimlane (horizontal)
- Swimlane (vertical)
- Trigger
- Process start
- Subprocess
- Activity
- Decision
- Parallellity
- Merging
- End
- Variable
- Random generator
- Resource
- Note
- Aggregation
- Cross-reference
- Performance indicator overview
- Performance indicator

and the following relation classes:

- Subsequent
- Sets variable
- Sets
- Uses
- has Note
- has Cross-reference
- Owns

1.4 IT system model

In the IT system model an overview of IT system architecture can be made by modelling systems, applications and infrastructure elements. IT system models can be build hierarchically using IT system sub models to e.g. illustrate a detailed structure of an IT system.









IT system models offer the following classes:









Application (see chap. 2.26, p. 130)



Service (see chap. 2.27, p. 134)

	Infrastructure element (see chap. 2.29, p. 140)
	Note (see chap. 2.19, p. 109)
	Aggregation (see chap. 2.20, p. 113)
	Swimlane (vertical) (see chap. 2.22, p. 119)
	Swimlane (horizontal) (see chap. 2.21, p. 116)
	Cross-reference (see chap. 2.30, p. 144)
	Performance indicator (see chap. 2.17, p. 98)
	Performance indicator overview (see chap. 2.16, p. 96)

IT system models offer the following relation classes:

	has (see chap. 3.14, p. 188)
	uses (see chap. 3.15, p. 189)
	Is dependent on (see chap. 3.16, p. 191)
	has Note (see chap. 3.18, p. 193)
	has Cross-reference (see chap. 3.19, p. 193)
	Owns (see chap. 3.17, p. 192)

The following modes are defined for **IT system models**:

- **Standard**

with the following classes:

- Application
- Service
- Infrastructure element
- Note
- Aggregation
- Swimlane (vertical)
- Swimlane (horizontal)
- Cross-reference

and the following relation classes:

- has
- uses
- Is dependent on
- has Note
- has Cross-reference

- **Service overview**

with the following classes:

Part III

- Service
- Note
- Aggregation
- Swimlane (vertical)
- Swimlane (horizontal)
- Cross-reference

and the following relation classes:

- has
- uses
- Is dependent on
- has Note
- has Cross-reference

- **Application overview**

with the following classes:

- Application
- Note
- Aggregation
- Swimlane (vertical)
- Swimlane (horizontal)
- Cross-reference

and the following relation classes:

- has
- uses
- Is dependent on
- has Note
- has Cross-reference

- **Infrastructure element overview**

with the following classes:

- Infrastructure element
- Note
- Aggregation
- Swimlane (vertical)
- Swimlane (horizontal)
- Cross-reference

and the following relation classes:

- has
- uses
- Is dependent on

- has Note
- has Cross-reference

- **Standard - including Performance indicators**

with the following classes:

- Application
- Service
- Infrastructure element
- Performance indicator
- Performance indicator overview
- Note
- Aggregation
- Swimlane (vertical)
- Swimlane (horizontal)
- Cross-reference

and the following relation classes:

- has
- uses
- Is dependent on
- Owns
- has Note
- has Cross-reference

1.5 Use case diagram

In Use case diagrams interactions between systems and involved parties are shown and described.

The involved parties have requirements for the system in order to reach goals. These requirements lead to a number of interactions with the system. Then the system performs actions to fulfil these requirements.

The ideal way (i.e. a series of steps and the communication with the involved parties) to deal with such a request is called a scenario in Unified modelling Language (UML). UML is a method to model object-oriented systems in complex software systems. Scenarios in UML are not explicitly modelled but can be additionally described in textual form.

There are many methods and scenarios to accomplish the user's goal such as *I would like to withdraw money from my bank account*. The money can e.g. be withdrawn using an ATM machine or by going to a bank counter. These are two of the possible scenarios. Later on, it is possible that the transaction cannot be completed and the customer cannot withdraw the money. Also scenarios have to be described to deal with exceptions, errors, etc.







All scenarios relating to the same user target are grouped into a use case which is represented by the ellipse in the diagram. The use case *Withdraw money from account* summarises all possible scenarios to withdraw money from an account. The use case, on the one hand, describes the responsibility of the system bank in relation to its customers. On the other hand it describes the requirements from the customers to the system.

Part III







In use case diagrams the users interacting with a system are shown and the requirements from the users which have to be fulfilled by the system are modelled. The requirements describe the internal system and the users the system environment. In use case diagrams particular importance is given to the interface between systems and the system environment. With the third modelling element, the system interface, this distinction can be emphasized.

Use cases are often used in the early phases of an IT project to support the requirements analysis. Requirements for a future or existing system and the involved parties are defined. Involved parties put requests to the system and therefore have a relation to the system. These relationships can be shown very clearly using a use case diagram.

Use case diagrams offer the following classes:

	actor (see chap. 2.1, p. 35)
	use case (see chap. 2.2, p. 37)
	system boundary (see chap. 2.3, p. 39)
	Note (see chap. 2.19, p. 109)
	Cross-reference (see chap. 2.30, p. 144)
	Swimlane (vertical) (see chap. 2.22, p. 119)
	Swimlane (horizontal) (see chap. 2.21, p. 116)

Use case diagrams offer the following relation classes:

	communicates (see chap. 3.5, p. 178)
	contains (see chap. 3.8, p. 181)
	uses (see chap. 3.10, p. 184)
	extends (see chap. 3.9, p. 182)
	has Note (see chap. 3.18, p. 193)
	Generalisation (see chap. 3.7, p. 180)
	has Cross-reference (see chap. 3.19, p. 193)

The following modes are defined for **Use case diagrams**:

- **Standard**

with the following classes:

- actor
- use case
- system boundary
- Note
- Cross-reference
- Swimlane (vertical)
- Swimlane (horizontal)

and the following relation classes:

- communicates
- contains
- uses
- extends
- has Note
- Generalisation
- has Cross-reference

1.6 Document model

Document models contain documents (templates), which are utilised in the processes (input, output to activities etc.). Document models can be build hierarchically using document sub models to e.g. illustrate a detailed structure of documents.

Document models offer the following classes:



Document (see chap. 2.18, p. 107)



Aggregation (see chap. 2.20, p. 113)



Note (see chap. 2.19, p. 109)



Cross-reference (see chap. 2.30, p. 144)



Swimlane (vertical) (see chap. 2.22, p. 119)



Swimlane (horizontal) (see chap. 2.21, p. 116)

Document models offer the following relation classes:



has Subdocument (see chap. 3.12, p. 186)



has Note (see chap. 3.18, p. 193)



has Cross-reference (see chap. 3.19, p. 193)

The following modes are defined for **Document models**:

- **Standard**

with the following classes:

- Document
- Aggregation
- Note
- Cross-reference
- Swimlane (vertical)
- Swimlane (horizontal)











and the following relation classes:

- has Subdocument
- has Note
- has Cross-reference











1.7 Working environment model

Working Environment models describe the structure of an organisation (organisation chart). Working Environment models can be build hierarchically using working environment sub models to e.g. illustrate a detailed structure of a working environment.

Working environment models offer the following classes:

-  **Organizational unit (see chap. 2.31, p. 145)**
-  **Performer (see chap. 2.32, p. 151)**
-  **Role (see chap. 2.33, p. 155)**
-  **Aggregation (see chap. 2.37, p. 162)**
-  **Note (see chap. 2.38, p. 164)**
-  **Swimlane (vertical) (see chap. 2.40, p. 169)**
-  **Swimlane (horizontal) (see chap. 2.39, p. 167)**
-  **Resource (see chap. 2.35, p. 158)**
-  **Cost center (see chap. 2.36, p. 160)**
-  **Position (see chap. 2.34, p. 156)**

Working environment models offer the following relation classes:

-  **Is subordinated (see chap. 3.20, p. 194)**
-  **has Resource (see chap. 3.21, p. 194)**
-  **Belongs to (see chap. 3.23, p. 195)**
-  **Is manager (see chap. 3.24, p. 196)**
-  **Has role (see chap. 3.25, p. 196)**
-  **has position (see chap. 3.22, p. 195)**
-  **Uses resource (see chap. 3.26, p. 197)**
-  **Is charged to (see chap. 3.27, p. 197)**
-  **Is cost center manager (see chap. 3.28, p. 198)**
-  **has Note (see chap. 3.29, p. 198)**

The following modes are defined for **Working environment models**:

- **Standard**

with the following classes:

- Organizational unit
- Performer
- Role
- Aggregation
- Note
- Swimlane (vertical)
- Swimlane (horizontal)

and the following relation classes:

- Is subordinated
- has Resource
- Belongs to
- Is manager
- Has role
- has position
- Uses resource
- Is charged to
- Is cost center manager
- has Note

- **Standard - including Resources**

with the following classes:

- Organizational unit
- Performer
- Role
- Resource
- Aggregation
- Note
- Swimlane (vertical)
- Swimlane (horizontal)

and the following relation classes:

- Is subordinated
- has Resource
- Belongs to
- Is manager
- Has role
- has position
- Uses resource

Part III

- Is charged to
- Is cost center manager
- has Note

- **Standard - with cost center**

with the following classes:

- Organizational unit
- Performer
- Role
- Cost center
- Aggregation
- Note
- Swimlane (vertical)
- Swimlane (horizontal)

and the following relation classes:

- Is subordinated
- has Resource
- Belongs to
- Is manager
- Has role
- has position
- Uses resource
- Is charged to
- Is cost center manager
- has Note

- **Organization**

with the following classes:

- Organizational unit
- Position
- Aggregation
- Note
- Swimlane (vertical)
- Swimlane (horizontal)

and the following relation classes:

- Is subordinated
- has Resource
- Belongs to
- Is manager
- Has role

- has position
- Uses resource
- Is charged to
- Is cost center manager
- has Note

- **Role diagram**

with the following classes:

- Role
- Aggregation
- Note
- Swimlane (vertical)
- Swimlane (horizontal)

and the following relation classes:

- Is subordinated
- has Resource
- Belongs to
- Is manager
- Has role
- has position
- Uses resource
- Is charged to
- Is cost center manager
- has Note

- **Resource diagram**

with the following classes:

- Organizational unit
- Performer
- Resource
- Aggregation
- Note
- Swimlane (vertical)
- Swimlane (horizontal)

and the following relation classes:

- Is subordinated
- has Resource
- Has role
- has position
- Uses resource

Part III

- Is charged to
- Is cost center manager
- has Note

- **All modeling objects**

with the following classes:

- Organizational unit
- Performer
- Role
- Position
- Resource
- Cost center
- Aggregation
- Note
- Swimlane (vertical)
- Swimlane (horizontal)

and the following relation classes:

- Is subordinated
- has Resource
- Belongs to
- Is manager
- Has role
- has position
- Uses resource
- Is charged to
- Is cost center manager
- has Note

2. Classes

In the following chapters you will find a description of all classes available for modelling. The current availability depends on the selected **model type** (see chap. 1., p. 16) on the one hand and on the selected view mode on the other hand.

Hint: A description of the **view modes** you will find in the previous chapters for the particular model types.

2.1 Class "actor"



An actor describes a role participating and interacting with the system.

When modelling a system interface it is not important, which of the actual persons (e.g. Smith, McDyes, etc.) are querying the system. All participating persons are grouped into roles due to their requirements and are assigned a role according to this. This ensures that from a modelling point of view only homogenous groups (e.g. customers and managers) will remain. Distinguished participants within one group who have the same demands towards the system are modelled with a single actor-symbol.

Ein Akteur (engl. "actor") beschreibt eine Rolle, die Beteiligte bezüglich des Systems einnehmen.

Für die Modellierung der Systemschnittstelle ist es nicht wichtig, welche realen Personen (z.B. Meier oder Huber) Anforderungen stellen. Alle Beteiligten werden anhand ihrer Anforderungen in Gruppen eingeteilt und bekommen (je nach Gruppe) eine entsprechende Rolle zugewiesen. Aus Modellierungssicht treten nur mehr homogene Gruppen (z.B. Kunden oder Manager) auf. Alle Beteiligten innerhalb einer Gruppe stellen an das System gleiche Anforderungen, haben dieselbe Rolle und werden mit einem einzigen Akteur-Symbol modelliert.

The following attributes are defined for the class "actor":

- **Name (chapter "Description"):**

- **Referenced organizational unit (chapter "Description"):**

It is possible to reference an organizational element (role, position, performer, organizational unit) from a working environment model, which is defined as an actor in the actual use case.

The reference can be selected or changed by clicking on the add-icon (symbol 'plus').

Referenzieren Sie ein Organisationselement (d.h. Rolle, Planstelle, Bearbeiter oder Organisationseinheit) aus einem Arbeitsumgebungsmodell, welches als Akteur im aktuellen Anwendungsfall definiert ist.

Die Referenz wird über das Hinzufügen-Icon ('Plus'-Symbol) ausgewählt bzw. geändert.

- **Description (chapter "Description"):**

Describe the characteristics of the actor.

The description will be used for documentation purposes.

Geben Sie hier eine Beschreibung ein, die den Akteur charakterisiert.

Dient der Dokumentation.

- **Comment (chapter "Description"):**

Describe the characteristics of the actor.

The description will be used for documentation purposes.

Geben Sie hier eine Beschreibung ein, die den Akteur charakterisiert.

Dient der Dokumentation.

- **Open questions (chapter "Description"):**

Here you can enter any open questions which are still to be answered for this actor.

If you enter any open questions, a red question mark appears above the object symbol on the drawing area.

Hinterlegen Sie hier eventuell noch vorhandene offene Fragen zu diesem Objekt.

Bei offenen Fragen erscheint auf der Zeichenoberfläche neben dem Objekt ein rotes Fragezeichen.

- **Color (chapter "Representation"):**

You can define the object color as follows:

- Select a color in the 'Color' window which can be opened by clicking on the dialog button (on the right above the attribute field).

- Enter a color name (e.g. 'cornflowerblue'; a list of the color names can be found in the user documentation or in the online help).

- Enter an hexadecimal value (e.g. '\$FFFFFF' for white), where the value begins with '\$' and contains then the red, green and blue values with two digits for each.

Die Farbe des Objekts kann definiert werden durch:

- die Auswahl einer Farbe über das Fenster "Farben", welches Sie durch Anklicken des Dialog-Buttons (rechts oberhalb des Attributfelds) öffnen

- die Eingabe eines Farbnamens (z.B. "cornflowerblue"; eine Liste finden Sie in Benutzerdokumentation und Online-Hilfe)

- die Eingabe eines Hexadezimalwerts (z.B. "\$FFFFFF" für white/weiß), wobei der Wert mit '\$' beginnt und daran anschließend - jeweils zweistellig - die Rot-, Grün-, und Blauwerte beinhaltet

- **Bezeichnung (chapter "Deutsch"):**

Geben Sie hier ein Name.

Dient der Dokumentation.

- **Beschreibung (chapter "Deutsch"):**

Geben Sie hier eine Beschreibung ein, die den Akteur charakterisiert.

Dient der Dokumentation..

Choose a name for the actor.

The name will be used for documentation purposes.

- **Kommentar (chapter "Deutsch"):**

Geben Sie einen Kommentar zu Ihrem Akteur ein.

Dient der Dokumentation.

Enter any comments about the actor.

For documentation purposes.

2.2 Class "use case"

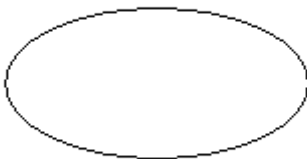

A use case describes a function that is visible for the user. It helps the user to achieve a certain goal. The size and number of use cases for a system are not given, and can be selected by the user for each particular circumstance.

Ein Anwendungsfall beschreibt eine dem Benutzer sichtbare Funktion. Er hilft dem Benutzer, ein konkretes Ziel zu erreichen.

Die Größe und Anzahl von Anwendungsfällen für ein System ist nicht vorgegeben und kann vom Modellierer, abhängig von den konkreten Umständen, gewählt werden.

Part III

The following attributes are defined for the class "use case":

- **Name (chapter "Description"):**

- **Description (chapter "Description"):**

Describe the characteristics of the use case.

The description will be used for documentation purposes.

Geben Sie eine charakterisierende Beschreibung des Anwendungsfalls an.

Dient der Dokumentation.

- **Comment (chapter "Description"):**

Enter any comments about the use case.

The comments will be used for documentation purposes.

Geben Sie einen Kommentar zum Anwendungsfall ein.

Dient der Dokumentation.

- **External documentation (chapter "Description"):**

The 'External documentation' enables the integration of existing design documents, as well as complementary external documents.

- **Details (chapter "Description"):**

The attribute 'Details' can be used to decompose the current use case within a separate use case diagram.

Geben Sie ein Anwendungsfalldiagramm an, mit dem Sie diesen Anwendungsfall in detaillierterer Form darstellen.

- **Open questions (chapter "Description"):**

Here you can enter any open questions which are still to be answered for this system boundary.

If you enter any open questions, a red question mark appears above the object symbol on the drawing area.

Hinterlegen Sie hier eventuell noch vorhandene offene Fragen zu diesem Objekt.

Bei offenen Fragen erscheint auf der Zeichenoberfläche neben dem Objekt ein rotes Fragezeichen.

- **Bezeichnung (chapter "Deutsch"):**

Geben Sie ein Name.

Dient der Dokumentation.

- **Beschreibung (chapter "Deutsch"):**

Geben Sie eine charakterisierende Beschreibung des Anwendungsfalls an.
Dient der Dokumentation.

Describe the characteristics of the object.

The description will be used for documentation purposes.

- **Kommentar (chapter "Deutsch"):**

Geben Sie einen Kommentar zum Anwendungsfall ein.
Dient der Dokumentation.

Enter any comments about the object.

The comments will be used for documentation purposes.

2.3 Class "system boundary"



With the system boundary several use cases can be summarised, which can be used to build a logical unit.

Mit der Systemgrenze können mehrere Anwendungsfälle, die eine logische Einheit bilden, zusammengefaßt werden.

The following attributes are defined for the class "system boundary":

- **Name (chapter "Description"):**

- **Representation (chapter "Description"):**

Select whether the object name should be displayed inside or outside the object.

Geben Sie an, ob der Name innerhalb oder außerhalb der Objektfläche dargestellt werden soll.

- **Description (chapter "Description"):**

Describe the characteristics of the system boundary.
The description will be used for documentation purposes.

Geben Sie eine charakterisierende Beschreibung der Systemgrenze ein.
Dient der Dokumentation.

- **Comment (chapter "Description"):**

Enter any comments about the system boundary.
The comments will be used for documentation purposes.

Geben Sie einen Kommentar zur Systemgrenze ein.
Dient der Dokumentation.

- **Open questions (chapter "Description"):**

Here you can enter any open questions which are still to be answered for this use case.
If you enter any open questions, a red question mark appears above the object symbol on the drawing area.

Hinterlegen Sie hier eventuell noch vorhandene offene Fragen zu diesem Objekt.
Bei offenen Fragen erscheint auf der Zeichenoberfläche neben dem Objekt ein rotes Fragezeichen.

- **Bezeichnung (chapter "Deutsch"):**

Geben sie eine Bezeichnung der Systemgrenze ein. Dient der Dokumentation

- **Beschreibung (chapter "Deutsch"):**

Geben Sie eine charakterisierende Beschreibung der Systemgrenze ein.
Dient der Dokumentation.

Describe the characteristics of the system boundary.
The description will be used for documentation purposes.

- **Kommentar (chapter "Deutsch"):**

Geben Sie einen Kommentar zur Systemgrenze ein.
Dient der Dokumentation.

Enter any comments about the system boundary.

The comments will be used for documentation purposes.

2.4 Class "Trigger"



A trigger is an event or specific circumstance which causes the start of a business process.

Ein Auslöser ist ein Ereignis oder ein Sachverhalt, der den Start eines Geschäftsprozesses bedingt.

The following attributes are defined for the class "Trigger":

- **Name (chapter "Description"):**

- **Referenced trigger (chapter "Description"):**

The trigger of the business process model can be referenced in this field (documents from a document model or processes from a process map).

The reference can be selected or changed by clicking on the add-icon (symbol 'plus').

The name of the referenced trigger will be displayed as a hyperlink in the object instead of the object name.

Referenzieren Sie jene Elemente (Dokumente aus einem Dokumentenmodell oder Prozesse bzw. Leistungen aus einer Prozesslandkarte), welche ein Auslöser des Geschäftsprozesses sind.

Die Referenz wird über das Hinzufügen-Icon ('Plus'-Symbol) ausgewählt bzw. geändert.

Der Name des referenzierten Auslösers wird als Hyperlink im Objekts statt dem Objektnamen angezeigt.

- **Description (chapter "Description"):**

Describe the characteristics of the trigger.

The description will be used for documentation purposes.

Geben sie eine Beschreibung ein.

Dient der Dokumentation.

- **Comment (chapter "Description"):**

Enter any comments about the trigger.

The comments will be used for documentation purposes.

Geben sie einen Kommentar ein.

Dient der Dokumentation.

- **External documentation (chapter "Description"):**

The attribute 'external documentation' allows the integration of existing information sources (documents, tables, graphics, intranet pages...) into the triggers of a business process model.

The integration is carried out by entering the path and the file name in the field 'Program arguments'.

When entered, external documents are displayed by a document symbol on the right side above the object.

Die "Externe Dokumentation" ermöglicht die Einbindung von bestehenden Informationsquellen (Dokumente, Tabellen, Grafiken, Intranet-Seiten ...) in die Auslöser eines Geschäftsprozeßmodells.

Die Einbindung erfolgt durch das Eintragen des Pfades und des Dateinamens im Feld 'Parameter'.

Eingetragene externe Dokumente werden durch ein Dokumenten-Symbol rechts oberhalb des Objekts angezeigt.

- **Referenced documents (chapter "Description"):**

Here you can reference documents from a document model, which are required for the description of the trigger.

The reference can be selected or changed by clicking on the add-icon (symbol 'plus').

When entered, referenced documents are displayed by a document symbol on the right side above the object.

Referenzieren Sie jene Dokumente aus einem Dokumentenmodell, welche für die Beschreibung des Auslösers notwendig sind.

Die Referenz wird über das Hinzufügen-Icon ('Plus'-Symbol) ausgewählt bzw. geändert.

Eingetragene referenzierte Dokumente werden durch ein Dokumenten-Symbol rechts oberhalb des Objekts angezeigt.

- **Open questions (chapter "Description"):**

Please enter any questions which are still to be answered for this object.

If you enter open questions, a red question mark appears above the object symbol on the drawing area.

Hinterlegen Sie hier eventuell noch vorhandene offene Fragen zu diesem Objekt.

Bei offenen Fragen erscheint auf der Zeichenoberfläche neben dem Objekt ein rotes Fragezeichen.

- **Referenced IT system elements (chapter "Description"):**

It is possible to reference IT system elements (application, service or infrastructure element) from an IT system model, which are triggers for the business process model.

The reference can be selected or changed by clicking on the add-icon (symbol 'plus').

When entered, IT system elements are displayed as a hyperlink above the activity if the option "Visualise referenced IT system elements" is enabled.

The IT system elements entered will be displayed as a hyperlink in the visualized reference overview (menu 'View' - menu item 'Views' - sub-menu item 'Visualize/hide reference overview') if the activated attribute "DEMI-/RACI Visibility" (DEMI-/RACI view in menu 'View' - menu item 'Views' - sub-menu item 'Configuration reference overview') in the line "IT" (using horizontal modelling direction) or in the column "IT" (using vertical modelling direction) is activated.

Referenzieren Sie jene IT systemelemente (d.h. Anwendung, Service oder Infrastrukturelement) aus einem IT systemmodell, welche Auslöser des Geschäftsprozesses sind.

Die Referenz wird über das Hinzufügen-Icon ('Plus'-Symbol) ausgewählt bzw. geändert.

Die eingetragenen IT systemelemente werden oberhalb der Aktivität als Hyperlink angezeigt, wenn die Option "Referenzierte IT systemelemente visualisieren" aktiviert ist.

Die eingetragenen IT systemelemente werden in der eingeblendeten Referenzenübersicht (Menü 'Ansicht' - Menüpunkt 'Sichten' - Untermenüpunkt 'Referenzenübersicht ein/ausblenden') bei aktivierter IT-Systeme-Sicht (Menü 'Ansicht' - Menüpunkt 'Sichten' - Untermenüpunkt 'Referenzenübersicht konfigurieren') in der Zeile "IT" (bei horizontaler Modellierungsrichtung) bzw. in der Spalte "IT" (bei vertikaler Modellierungsrichtung) als Hyperlink angezeigt.

- **Visualise referenced IT system elements (chapter "Description"):**

- **Bezeichnung (chapter "Deutsch"):**

Geben sie ein Name.

Dient der Dokumentation.

Choose a name for the object.

The name will be used for documentenation purposes.

- **Beschreibung (chapter "Deutsch"):**

Geben sie eine Beschreibung ein.

Dient der Dokumentation.

Enter a characterizing description.

For documentation purposes.

- **Kommentar (chapter "Deutsch"):**

Geben sie einen Kommentar ein.

Dient der Dokumentation.

Enter any comments about the object.

The comments will be used for documentation purposes.

2.5 Class "Process start"



Every business process model must contain exactly one Process start object. It symbolizes the beginning of the business process model.

Various variables relevant to the process are contained in it.

The object 'Process start' should have no predecessor and only one Subsequent relation. .

edes Geschäftsprozeßmodell muß genau ein Startobjekt enthalten. Dieses stellt den Anfang des Geschäftsprozesses dar.

Das Objekt "Prozeßstart" hat keinen Vorgänger und maximal einen Nachfolger und kann mit Variablen belegt werden.

The following attributes are defined for the class "Process start":

- **Name (chapter "Description"):**

- **Order (chapter "Description"):**

This attribute can be set with the help of the 'Object numbering' function, which numbers the objects of the business process model.

This can be useful for example within the component 'Documentation', to ensure that all objects are documented in the required order.

Dieses Attribut kann mit Hilfe der Numerierungsfunktion, bei der die Objekte des Geschäftsprozeßmodells numeriert werden, belegt werden.

Die Reihenfolge wird beispielsweise bei Verwendung der Zusatzkomponente "Dokumentationskomponente" herangezogen, um die Objekte in gewünschter Abfolge zu dokumentieren.

- **Description (chapter "Description"):**

Describe the characteristics of the process start.

The description will be used for documentation purposes.

Geben Sie eine charakterisierende Beschreibung des Prozeßstartes ein.
Dient der Dokumentation.

- **Comment (chapter "Description"):**

Enter any comments about the process start.
The comments will be used for documentation purposes.

Geben Sie einen Kommentar zum Prozeßstart ein (bspw. Eigenarten der Realisierung, technische Besonderheiten ...).
Dient der Dokumentation

- **Trigger (chapter "Description"):**

Enter a trigger for the business process model.
For documentation purposes.

Geben Sie den Auslöser dieses Geschäftsprozesses ein.
Dient der Dokumentation.

- **Result (chapter "Description"):**

The the result of the business process can be described here.
The results described will be used for documentation purposes.

Geben Sie das Ergebnis des Geschäftsprozesses ein.
Dient der Dokumentation.

- **Process responsibility (chapter "Description"):**

Enter the information for the Process responsible person as follows:

Role/Performer: Select a role or a performer from a working environment model. This role or performer is responsible for the process.

Classification: Enter whether the responsible role/performer is mainly responsible/on behalf of/supporting for the process.

Description: General description for the ownership.

Tragen Sie Informationen für den Prozeßverantwortlichen folgendermaßen ein:

Rolle/Bearbeiter: Wählen Sie eine Rolle oder einen Bearbeiter aus einem Arbeitsumgebungsmodell aus, die/der für den Prozeß verantwortlich ist.

Klassifikation: Geben Sie an, ob die verantwortliche Rolle/der verantwortliche Bearbeiter hauptverantwortlich, stellvertretend oder unterstützend ist.

Beschreibung: Geben Sie eine möglichst informative Beschreibung der Verantwortung ein.

- **Open questions (chapter "Description"):**

Here you can enter any open questions which are still to be answered for this start object.

If you enter any open questions, a red question mark appears above the object symbol on the drawing area.

Hinterlegen Sie hier eventuell noch vorhandene offene Fragen zu diesem Objekt.

Bei offenen Fragen erscheint auf der Zeichenoberfläche neben dem Objekt ein rotes Fragezeichen.

- **Input (chapter "Documents"):**

In this field, you can reference documents from a document model, which are used as input for the business process model.

The reference can be selected or changed by clicking on the add-icon (symbol 'plus').

If a document is entered, the input document will be displayed as a hyperlink in the visualized reference overview (menu 'View' - menu item 'Views' - sub-menu item 'Visualize/hide reference overview') if the attribute "DEMI-/RACI Visibility" (DEMI-/RACI view in menu 'View' - menu item 'Views' - sub-menu item 'Configuration reference overview') in the line "In" (using horizontal modelling direction) or in the column "In" (using vertical modelling direction) is activated.

Referenzieren Sie jene Dokumente aus einem Dokumentenmodell, welche Input für den Geschäftsprozeß sind.

Die Referenz wird über das Hinzufügen-Icon ('Plus'-Symbol) ausgewählt bzw. geändert.

Die eingetragenen Input-Dokumente werden in der eingeblendeten Referenzenübersicht (Menü 'Ansicht' - Menüpunkt 'Sichten' - Untermenüpunkt 'Referenzenübersicht ein/ausblenden') bei aktivierter Input/Output-Sicht (Menü 'Ansicht' - Menüpunkt 'Sichten' - Untermenüpunkt 'Referenzenübersicht konfigurieren') in der Zeile "In" (bei horizontaler Modellierungsrichtung) bzw. in der Spalte "In" (bei vertikaler Modellierungsrichtung) als Hyperlink angezeigt.

- **Output (chapter "Documents"):**

In this field, you can reference documents from a document model, which are created as output from business process models.

The reference can be selected or changed by clicking on the add-icon (symbol 'plus').

If a document is entered, the output documents will be displayed as a hyperlink in the visualized reference overview (menu 'View' - menu item 'Views' - sub-menu item 'Visualize/hide reference overview') if the attribute "DEMI-/RACI Visibility" (DEMI-/RACI view in menu 'View' - menu item 'Views' - sub-menu item 'Configuration reference overview') in the line "Out" (using horizontal modelling direction) or in the column "Out" (using vertical modelling direction) is activated.

Referenzieren Sie jene Dokumente aus einem Dokumentenmodell, welche als Output des Geschäftsprozesses entstehen.

Die Referenz wird über das Hinzufügen-Icon ('Plus'-Symbol) ausgewählt bzw. geändert.

Die eingetragenen Output-Dokumente werden in der eingeblendeten Referenzenübersicht (Menü 'Ansicht' - Menüpunkt 'Sichten' - Untermenüpunkt 'Referenzenübersicht ein/ausblenden') bei aktivierter Input/Output-Sicht (Menü 'Ansicht' - Menüpunkt 'Sichten' - Untermenüpunkt 'Referen-

zenübersicht konfigurieren') in der Zeile "Out" (bei horizontaler Modellierungsrichtung) bzw. in der Spalte "Out" (bei vertikaler Modellierungsrichtung) als Hyperlink angezeigt.

- **Referenced documents (chapter "Documents"):**

It is possible to reference documents from a document model, which are required for the performance of the business process.

The reference can be selected or changed by clicking on the add-icon (symbol 'plus').

When entered, referenced documents are displayed by a document symbol on the right side above the object.

Referenzieren Sie jene Dokumente aus einem Dokumentenmodell, welche für die Durchführung des Geschäftsprozesses notwendig sind.

Die Referenz wird über das Hinzufügen-Icon ('Plus'-Symbol) ausgewählt bzw. geändert.

Eingetragene referenzierte Dokumente werden durch ein Dokumenten-Symbol rechts oberhalb des Objekts angezeigt.

- **External documentation (chapter "Documents"):**

The attribute "Externe Dokumentation" (external documentation) allows the integration of existing information sources (documents, tables, graphics, intranet pages...) into the start object of a business process model.

The integration is carried out by entering the path and the file name in the field 'Program arguments'.

When entered, external documents are displayed by a document symbol on the right side above the object.

Die "Externe Dokumentation" ermöglicht die Einbindung von bestehenden Informationsquellen (Dokumente, Tabellen, Grafiken, Intranet-Seiten ...) in das Startobjekt eines Geschäftsprozeßmodells.

Die Einbindung erfolgt durch das Eintragen des Pfades und des Dateinamens im Feld 'Parameter'.

Eingetragene externe Dokumente werden durch ein Dokumenten-Symbol rechts oberhalb des Objekts angezeigt.

- **Referenced IT system elements (chapter "System"):**

It is possible to reference one or more applications, IT infrastructure elements or services which will be used or which are necessary within the business process.

Referenzieren Sie hier ein oder mehrere Anwendungen, Infrastrukturelemente oder Services, die im Geschäftsprozeß genutzt bzw. benötigt werden werden.

- **Referenced products (chapter "Products"):**

In this field, you can reference one or more products or product components which will be worked on during the process.

Referenzieren Sie hier ein oder mehrere Produkte oder Produktkomponenten, die im Geschäftsprozeß bearbeitet werden.

- **Quantity (chapter "Simulation data"):**

Enter the number of occurrences of the business process within the chosen time period.

The value in this field will be used by the 'Capacity Analysis' simulation algorithm.

Geben Sie die Häufigkeit des Auftretens im gewählten Bezugszeitraum an.

Dieser Wert wird in der Simulation (Belastungsanalyse) verwendet.

- **Time period (chapter "Simulation data"):**

Select the time period (per day, per month or per year) in which the business process occurs 'quantity' number of times.

Wählen Sie den Zeitraum für das Auftreten der unter "Menge" angegebenen Anzahl von Geschäftsprozessen (Fälle pro Tag, pro Monat oder pro Jahr).

Wird in der Simulation (Belastungsanalyse) verwendet.

- **Process calendar (chapter "Simulation data"):**

The Process start calendar is evaluated and used in the simulation algorithm "Workload Analysis".

It describes the occurrences of the business processes over one year. It is possible to define a number of "typical" day profiles which can then be assigned to all the days of the year. The day profile is constructed by time intervals within which a probability distribution is assigned. Those probability distributions within the various day profiles describe the time between two process starts.

Dialogue windows can give you assistance in defining the calendar.

Der Prozeßkalender wird in der Simulation (Auslastungsanalyse) ausgewertet.

Er gibt das Auftreten des Geschäftsprozesses bezogen auf ein Jahr an. Sie können beliebig viele "Tagesprofile" definieren, die "typische" Tage beschreiben und diese Tagesprofile den einzelnen Tagen des Jahres zuordnen. Ein Tagesprofil besteht aus einer Folge von Zeitintervallen, denen Zufallsverteilungen zugeordnet sind. Diese Zufallsverteilungen stehen für den Abstand zwischen zwei Prozeßstarts.

Die Dialogfenster unterstützen Sie bei der Definition des Kalenders.

- **Tolerance waiting time (chapter "Simulation data"):**

Enter the tolerance waiting time, after which the process should be cancelled.

This will only be evaluated during the Workload Analysis.

Geben Sie die Toleranzwartezeit an, nach der der Prozeß abgebrochen werden soll.

Wird in der Simulation (nur in der Auslastungsanalyse) ausgewertet.

- **Abandon after tolerance waiting time (chapter "Simulation data"):**

If this option is selected, and the time interval between the process start and the execution of the first activity is greater than the tolerance waiting time, the process will be cancelled.

This will only be evaluated during the Workload Analysis.

Geben Sie an, ob der Prozeß abgebrochen wird, wenn zwischen Prozeßbeginn und Bearbeitungsbeginn der ersten Aktivität eine Wartezeit auftritt, die größer als die Toleranzwartezeit ist.

Wird bei der Simulation (nur in der Auslastungsanalyse) ausgewertet.

- **Cost driver (chapter "Simulation data"):**

Enter the cost driver for the process cost analysis.

Geben Sie den Kostentreiber für die Prozeßkostenanalyse an.

- **Cost driver quantity (chapter "Simulation data"):**

Enter the quantity of the cost driver for the process cost analysis.

Geben Sie die Menge des Kostentreibers für die Prozeßkostenanalyse an.

- **Aggregated cycle time (chapter "Simulation results"):**

The value of this attribute contains an estimation of the expected cycle time of the business process.

More information about the relevant period can be found in the attribute 'Info on results'.

Der Wert dieses Attributs enthält eine Schätzung für den Erwartungswert der Durchlaufzeit des Geschäftsprozesses.

Nähere Informationen zum Bezugszeitraum finden Sie im Attribut "Ergebnisinfo".

- **Aggregated execution time (chapter "Simulation results"):**

The value of this attribute contains an aggregated value of the expected execution time for the business process.

More information can be found in the attribute 'Info on results'.

Der Wert dieses Attributs enthält eine Schätzung für den Erwartungswert der Bearbeitungszeit dieses Geschäftsprozesses.

Nähere Informationen zum Bezugszeitraum finden Sie im Attribut "Ergebnisinfo".

- **Aggregated waiting time (chapter "Simulation results"):**

The value of this attribute contains an aggregated value of the waiting time expected for the business process.

More information can be found in the attribute 'Info on results'.

Der Wert dieses Attributs enthält eine Schätzung für den Erwartungswert der Wartezeit des Geschäftsprozesses.

Nähere Informationen zum Bezugszeitraum finden Sie im Attribut "Ergebnisinfo".

- **Aggregated resting time (chapter "Simulation results"):**

The value of this attribute contains an aggregated value of the resting time for the business-process.

More information about the relevant period can be found in the attribute 'Info on results'.

Der Wert dieses Attributs enthält eine Schätzung für den Erwartungswert der Liegezeit des Geschäftsprozesses.

Nähere Informationen zum Bezugszeitraum finden Sie im Attribut "Ergebnisinfo".

- **Aggregated transport time (chapter "Simulation results"):**

The value of this attribute contains an aggregated value of the transport time for the business-process.

More information about the relevant period can be found in the attribute 'Info on results'.

Der Wert dieses Attributs enthält eine Schätzung für den Erwartungswert der Transportzeit des Geschäftsprozesses.

Nähere Informationen zum Bezugszeitraum finden Sie im Attribut "Ergebnisinfo".

- **Aggregated costs (chapter "Simulation results"):**

The value of this attribute contains an estimation of the expected activity-costs of this business process.

More information about the relevant period can be found in the attribute 'Info on result'.

Der Wert dieses Attributs enthält eine Schätzung für den Erwartungswert der Aktivitätskosten des Geschäftsprozesses.

Nähere Informationen zum Bezugszeitraum finden Sie im Attribut "Ergebnisinfo".

- **Aggregated personnel costs (chapter "Simulation results"):**

The value of this attribute contains an estimation of the expected value of the personnel costs of the business process.

More information about the relevant period can be found in the attribute 'Info on results'.

Der Wert dieses Attributs enthält eine Schätzung für den Erwartungswert der Personalkosten des Geschäftsprozesses.

Nähere Informationen zum Bezugszeitraum finden Sie im Attribut "Ergebnisinfo".

- **Info on results (chapter "Simulation results"):**

The value of this attribute gives more information about the last evaluation carried out.

Der Wert dieses Attributs liefert nähere Informationen zur zuletzt durchgeführten Auswertung, deren Ergebnisse in das Modell übernommen wurden.

- **Bezeichnung (chapter "Deutsch"):**

Geben Sie eine Bezeichnung des Prozeßstarts an. Dient der Dokumentation.

- **Beschreibung (chapter "Deutsch"):**

Geben Sie einen Kommentar zum Prozeßstart ein (bspw. Eigenarten der Realisierung, technische Besonderheiten ...).

Dient der Dokumentation.

Enter any comments about the Process start.

The comments are used for documentation purposes.

- **Kommentar (chapter "Deutsch"):**

Geben Sie einen Kommentar zum Prozeßstart ein.

Dient der Dokumentation.

Enter a comment for the Process start.

For documentation purposes.

2.6 Class "Subprocess"



It is possible to call other processes with the object 'Subprocess'.

This makes sense especially when a particular process is carried out in several areas of the business. Rather than repeat the same process within a larger model a number of times, a subprocess can be called whenever necessary. The Subprocess object can also be useful when you want to structure your business processes to maximise clarity.

It must have at least one predecessor and at most one Subsequent relation.

If the name of a business process model is entered in the attribute 'Referenced subprocess', then that name will be appear on the graphical representation. Otherwise the object name will be shown.

Sie können über das Objekt "Prozeßaufruf" andere Prozesse aufrufen. Dies ist besonders dann sinnvoll, wenn Sie einen Subprozeß innerhalb eines Modells mehrmals aufrufen oder wenn Sie Ihren Geschäftsprozeß strukturieren wollen, um die Übersichtlichkeit zu erhöhen.

Das Objekt "Prozeßaufruf" muß mindestens einen Vorgänger und darf maximal einen Nachfolger haben.

Ist im Attribut "aufgerufener Prozeß" ein Geschäftsprozeßmodell eingetragen, wird der Name desselben angezeigt. Anderenfalls ist der eingetragene Objektname sichtbar.

The following attributes are defined for the class "Subprocess":

- **Name (chapter "Description"):**

- **Referenced subprocess (chapter "Description"):**

It is possible to reference a business process model, which is called by the current business process as a sub-process.

The reference can be selected or changed by clicking on the add-icon (symbol 'plus').

If the option 'show name and reference' is disabled (default setting), the name of the referenced process will be displayed as a hyperlink beneath the object instead of the object name.

If the option 'show name and reference' is enabled, the name of the referenced process will be displayed as a hyperlink beneath the object name in a smaller font size.

Referenzieren Sie ein Geschäftsprozeßmodell, welches als Subprozeß aus dem aktuellen Geschäftsprozeß aufgerufen wird.

Die Referenz wird über das Hinzufügen-Icon ('Plus'-Symbol) ausgewählt bzw. geändert.

Bei deaktivierter Option "Name und Referenz anzeigen" (Standardeinstellung) wird der Name des referenzierten Prozesses als Hyperlink unterhalb des Objekts statt dem Objektnamen angezeigt.

Bei aktivierter Option "Name und Referenz anzeigen" wird der Name des referenzierten Prozesses als Hyperlink unterhalb des Objektname in kleinerer Schrift angezeigt.

- **Display name and reference (chapter "Description"):**

If this option is activated, both the object name and the model name of the subprocess are displayed in the model graphic.

Aktivieren Sie diese Option, um sowohl den Objektname als auch den Modellnamen des aufgerufenen Prozesses in der Modellgrafik darzustellen.

- **Order (chapter "Description"):**

This attribute can be set with the help of the 'Object numbering' function, which numbers the objects of the business process model.

This can be useful for example within the component 'Documentation', to ensure that all objects are documented in the required order.

Dieses Attribut kann mit Hilfe der Numerierungsfunktion, mit der die Objekte des Geschäftsprozeßmodells nummeriert werden, belegt werden.

Die Reihenfolge wird beispielsweise bei Verwendung der Zusatzkomponente "Dokumentationskomponente" herangezogen, um die Objekte in gewünschter Abfolge zu dokumentieren.

- **Description (chapter "Description"):**

Describe the characteristics of the subprocess.

The description will be used for documentation purposes.

Geben Sie eine charakterisierende Beschreibung des Prozeßaufrufs ein.

Dient der Dokumentation.

- **Comment (chapter "Description"):**

Enter any comments about the subprocess.

The comments will be used for documentation purposes.

Geben Sie einen Kommentar zum Prozeßaufruf ein.

Dient der Dokumentation.

- **Open questions (chapter "Description"):**

Here you can enter any open questions which are still to be answered for this process.

If you enter any open questions, a red question mark appears above the object symbol on the drawing area.

Hinterlegen Sie hier eventuell noch vorhandene offene Fragen zu diesem Objekt.

Bei offenen Fragen erscheint auf der Zeichenoberfläche neben dem Objekt ein rotes Fragezeichen.

- **Performer (chapter "Working environment"):**

It is possible to assign a performer, that is, a reference between business processes and working environments.

The assigned performer will be used in all activities of the referenced process. In cases where this process references to another process, this performer will also be used in that process unless a new performer is assigned.

At the top right of the field "Performer" you will find a dialogue button which will give assistance in making performer assignments.

The value of this attribute is needed for the simulation.

Apart from the static elements of AQL, the dynamic elements of "performer of" and "done by" can also be used in the Capacity and Workload analysis.

"performer of": process intern, syntax: performer of <Activity>

The result is the performer of the working environment model, who executed the activity during simulation.

In this way it is ensured that an activity will be executed by the same performer that was assigned in the performer field.

Example: performer of "Contract be filed"

"done by": process interreferenced, syntax: done by <Variable>

The result is the performer of the working environment model, who executes the activity during simulation, at which the variable refers to. To use this construction the name of the variable of the referred activity should be entered in the "done by" attribute.

Example: done by "Contract performer"

Sie können eine "Bearbeiterzuordnung" (eine Verknüpfung von Geschäftsprozessen und Arbeitsumgebungen) vornehmen.

Der hier eingetragene Bearbeiter wird im aufgerufenen Prozeß in allen Aktivitäten verwendet. Ruft dieser Prozeß wieder Prozesse auf, so gilt der Bearbeiter auch für diese, wenn in den Aktivitäten keine weitere Bearbeiterzuordnung eingetragen ist.

Rechts über dem Feld "Bearbeiter" befindet sich ein Button für die Eingabehilfe.

Der Wert dieses Attributs wird für die Simulation benötigt.

Neben den statischen Elementen von AQL können zur Bearbeiterzuordnung insbesondere die beiden dynamischen Konstrukte "hat erledigt" und "erledigt durch" in der Be- und Auslastungsanalyse eingesetzt werden.

"hat erledigt": prozeßintern; Syntax: hat erledigt <Aktivität>

Das Ergebnis ist jener Bearbeiter aus dem Arbeitsumgebungsmodell, der die Aktivität während eines Simulationslaufs ausgeführt hat.

Damit wird gewährleistet, daß die Aktivität vom selben Bearbeiter ausgeführt wird, wie die in der Bearbeiterzuordnung referenzierte Aktivität (nützlich, wenn z.B. in einer Abteilung mehrere Bearbeiter sitzen, aber nur jeweils einer von ihnen einen kompletten Ablauf durchführt).

Beispiel: hat erledigt "Vertrag ablegen"

"erledigt durch": prozeßübergreifend; Syntax: erledigt durch <Variable>

Das Ergebnis ist jener Bearbeiter aus dem Arbeitsumgebungsmodell, der die durch diese Variable referenzierte Aktivität während eines Simulationslaufs ausgeführt hat. Zur Verwendung dieses Konstrukts ist es allerdings nötig, im Attribut 'Erledigt durch' der referenzierten Aktivität den Namen der Variablen einzutragen.

Beispiel: erledigt durch "Vertragsbearbeiter"

- **Aggregated execution time (chapter "Simulation results"):**

This attribute contains the aggregated execution time determined by the simulation for the business process model entered in the attribute 'Referenced subprocess' with respect to a year or a business process.

(More information about the relevant period can be found in the referenced business process model in the attribute 'Info on results' of the Process start object).

If no model has been referenced, the default value '00:000:00:00:00' is displayed.

Note: The attribute value is automatically updated and cannot be changed.

Dieses Attribut enthält die durch Simulation ermittelte Bearbeitungszeit des im Prozeßaufruf referenzierten Geschäftsprozeßmodells.

Nähere Informationen zum Bezugszeitraum (entweder ein Jahr oder ein einzelner Geschäftsprozeß) finden Sie im referenzierten Geschäftsprozeßmodell: Objekt Prozeßstart, Attribut "Ergebnis-info"

Sollte kein Modell referenziert sein, wird der Standardwert '00:000:00:00:00' angezeigt.

Hinweis: Der Attributwert wird automatisch aktualisiert und kann nicht manuell verändert werden.

- **Aggregated waiting time (chapter "Simulation results"):**

This attribute contains the aggregated waiting time determined by the simulation for the business process model entered in the attribute 'Referenced subprocess' with respect to a year or a business process.

(More information about the relevant period can be found in the referenced business process model in the attribute 'Info on results' of the Process start object).

If no model has been referenced, the default value '00:000:00:00:00' is displayed.

Note: The attribute value is automatically updated and cannot be changed.

Dieses Attribut enthält die durch Simulation ermittelte Wartezeit des im Prozeßaufruf referenzierten Geschäftsprozeßmodells.

Nähere Informationen zum Bezugszeitraum (entweder ein Jahr oder ein einzelner Geschäftsprozeß) finden Sie im referenzierten Geschäftsprozeßmodell: Objekt Prozeßstart, Attribut "Ergebnisinfo"

Sollte kein Modell referenziert sein, wird der Standardwert '00:000:00:00:00' angezeigt.

Hinweis: Der Attributwert wird automatisch aktualisiert und kann nicht manuell verändert werden.

- **Aggregated resting time (chapter "Simulation results"):**

This attribute contains the aggregated resting time determined by the simulation for the business process model entered in the attribute 'Referenced subprocess' with respect to a year or a business process.

(More information about the relevant period can be found in the referenced business process model in the attribute 'Info on results' of the Process start object).

If no model has been referenced, the default value '00:000:00:00:00' is displayed.

Note: The attribute value is automatically updated and cannot be changed

Dieses Attribut enthält die durch Simulation ermittelte Liegezeit des im Prozeßaufruf referenzierten Geschäftsprozeßmodells.

Nähere Informationen zum Bezugszeitraum (entweder ein Jahr oder ein einzelner Geschäftsprozeß) finden Sie im referenzierten Geschäftsprozeßmodell: Objekt Prozeßstart, Attribut "Ergebnisinfo"

Sollte kein Modell referenziert sein, wird der Standardwert '00:000:00:00:00' angezeigt.

Hinweis: Der Attributwert wird automatisch aktualisiert und kann nicht manuell verändert werden.

- **Aggregated transport time (chapter "Simulation results"):**

This attribute contains the aggregated transport time determined by the simulation for the business process model entered in the attribute 'Referenced subprocess' with respect to a year or a business process.

(More information about the relevant period can be found in the referenced business process model in the attribute 'Info on results' of the Process start object).

If no model has been referenced, the default value '00:000:00:00:00' is displayed.

Note: The attribute value is automatically updated and cannot be changed.

Dieses Attribut enthält die durch Simulation ermittelte Transportzeit des im Prozeßaufruf referenzierten Geschäftsprozeßmodells.

Nähere Informationen zum Bezugszeitraum (entweder ein Jahr oder ein einzelner Geschäftsprozeß) finden Sie im referenzierten Geschäftsprozeßmodell: Objekt Prozeßstart, Attribut "Ergebnisinfo"

Sollte kein Modell referenziert sein, wird der Standardwert '00:000:00:00:00' angezeigt.

Hinweis: Der Attributwert wird automatisch aktualisiert und kann nicht manuell verändert werden.

- **Aggregated costs (chapter "Simulation results"):**

This attribute contains the aggregated costs determined by the simulation for the business process model entered in the attribute 'Referenced subprocess' with respect to a year or a business process.

(More information about the relevant period can be found in the referenced business process model in the attribute 'Info on results' of the Process start object).

If no model has been referenced, the default value '00:000:00:00:00' is displayed.

Note: The attribute value is automatically updated and cannot be changed.

Dieses Attribut enthält die durch Simulation ermittelten Kosten des im Prozeßaufruf referenzierten Geschäftsprozeßmodells.

Nähere Informationen zum Bezugszeitraum (entweder ein Jahr oder ein einzelner Geschäftsprozeß) finden Sie im referenzierten Geschäftsprozeßmodell: Objekt Prozeßstart, Attribut "Ergebnisinfo"

Sollte kein Modell referenziert sein, wird der Standardwert '0,000000' angezeigt.

Hinweis: Der Attributwert wird automatisch aktualisiert und kann nicht manuell verändert werden.

- **Bezeichnung (chapter "Deutsch"):**

Geben Sie eine Bezeichnung des Prozeßaufrufes ein. Dient der Dokumentation.

- **Beschreibung (chapter "Deutsch"):**

Geben Sie eine charakterisierende Beschreibung des Prozeßaufrufs ein.

Dient der Dokumentation.

Describe the characteristics of the object.

The description will be used for documentation purposes.

- **Kommentar (chapter "Deutsch"):**

Geben Sie einen Kommentar zum Prozeßaufruf ein.

Dient der Dokumentation.

Enter any comments about the subprocess.

The comments will be used for documentation purposes.

2.7 Class "Activity"



Activities describe which tasks in a business process model are to be executed.

The object 'Activity' has at least one predecessor and at most one Subsequent. The level of granularity at which activities are described can vary according to the requirements of the modeller.

An activity can be set with one or more variables.

Aktivitäten beschreiben Tätigkeiten, die in einem Geschäftsprozeßmodell ausgeführt werden.

Das Objekt "Aktivität" hat mindestens einen Vorgänger und genau einen Nachfolger.

Eine Aktivität kann mit einer oder mehreren Variablen belegt werden.

The following attributes are defined for the class "Activity":

- **Name (chapter "Description"):**

- **Order (chapter "Description"):**

This attribute can be set with the help of the 'Object numbering' function, which numbers the objects of the business process model.

This can be useful for example within the component 'Documentation', to ensure that all objects are documented in the required order.

Dieses Attribut kann mit Hilfe der Numerierungsfunktion, mit der die Objekte des Geschäftsprozeßmodells numeriert werden, belegt werden.

Die Reihenfolge wird beispielsweise bei Verwendung der Zusatzkomponente "Dokumentationskomponente" herangezogen, um die Objekte in gewünschter Abfolge zu dokumentieren.

- **Description (chapter "Description"):**

Describe the characteristics of the activity.

The description will be used for documentation purposes.

Geben Sie eine charakterisierende Beschreibung der Aktivität an.

Dient der Dokumentation.

- **Comment (chapter "Description"):**

Enter any comments about the activity.

The comments will be used for documentation purposes.

Geben Sie einen Kommentar zur Aktivität an.

Dient der Dokumentation.

- **Responsible role (chapter "Description"):**

It is possible to reference a role from a working environment model, which is responsible for the realization of the activity.

The reference can be selected or changed by clicking on the add-icon (symbol 'plus').

The defined role will be transformed automatically into the performer assignment expression and assigned to the attribute 'Performer' (chapter 'Working environment') for the simulation.

When entered, a responsible role is displayed as a hyperlink in the activity if the option "Visualise responsible role" is enabled.

If a responsible role is entered, it will be displayed as a hyperlink in the visualized reference overview (menu 'View' - menu item 'Views' - sub-menu item 'Visualize/hide reference overview') if the attribute "DEMI-/RACI visibility" (DEMI-/RACI view in menu 'View' - menu item 'Views' - sub-menu item 'Configuration reference overview') in the line "V" (using horizontal modelling direction) or in the column "V" (using vertical modelling direction) is activated.

Referenzieren Sie jene Rolle aus einem Arbeitsumgebungsmodell, welche für die Durchführung der Aktivität verantwortlich ist.

Die Referenz wird über das Hinzufügen-Icon ('Plus'-Symbol) ausgewählt bzw. geändert.

Die hier definierte Rolle wird automatisch in einen gültigen Bearbeitungsordnungsdruck umgewandelt und dem Attribut 'Bearbeiter' (Kapitel 'Arbeitsumgebung') für die Simulation zugewiesen.

Eine eingetragene verantwortliche Rolle wird in der Aktivität als Hyperlink angezeigt, wenn die Option "Verantwortliche Rolle visualisieren" aktiviert ist.

Eine eingetragene verantwortliche Rolle wird in der eingblendeten Referenzenübersicht (Menü 'Ansicht' - Menüpunkt 'Sichten' - Untermenüpunkt 'Referenzenübersicht ein/ausblenden') bei aktivierter Verantwortliche Rolle-Sicht (Menü 'Ansicht' - Menüpunkt 'Sichten' - Untermenüpunkt 'Referenzenübersicht konfigurieren') in der Zeile "V" (bei horizontaler Modellierungsrichtung) bzw. in der Spalte "V" (bei vertikaler Modellierungsrichtung) als Hyperlink angezeigt.

- **Display responsible role (chapter "Description"):**

- **Classification (chapter "Description"):**

Enter one or more classification characteristics of the activity (for documentation purposes).

The selection of the following values will be displayed graphically in the activity object:

- "manual" by the Symbol 'Hand'
- "automatic" by the symbol 'Computer'
- "semi-automatic" by the symbols 'Computer' and 'Hand'
- "planning" by the symbol 'Reconciliation'
- "checking" by the symbol 'Eye'

- "administrating" by the symbol 'Reconciliation'
- "executing" by the symbol 'Tool'
- "value adding" by the symbol 'Dollars'
- "communicating" by the symbol 'Telephone'
- "external" by the symbol 'Globe'

HINT:

The multiple selection of "manual", "automatic" and/or "semi-automatic" will be displayed as 'Error', because this combination should not be used.

A multiple selection of other values will NOT be displayed graphically in the activity.

Geben Sie ein oder mehrere Klassifikationsmerkmale der Aktivität an. (Dient der Dokumentation.)

Die Auswahl folgender Werte wird im Aktivitätsobjekt grafisch dargestellt:

- "manuell" (manual) durch das Symbol 'Hand'
- "automatisch" (automatic) durch das Symbol 'Computer'
- "semiautomatisch" (semi-automatic) durch die Symbole 'Computer' und 'Hand'
- "planend" (planning) durch das Symbol 'Abstimmung'
- "kontrollierend" (checking) durch das Symbol 'Auge'
- "verwaltend" (administrating) durch das Symbol 'Kartei'
- "ausführend" (executing) durch das Symbol 'Werkzeug'
- "wertschöpfend" (value adding) durch das Symbol 'Dollars'
- "kommunizierend" (communicating) durch das Symbol 'Telefon'
- "extern" (external) durch das Symbol 'Globus'

HINWEIS:

Die Mehrfachauswahl von "manuell", "automatisch" und/oder "semiautomatisch" wird als 'Fehler' dargestellt, da diese Kombination nicht vorkommen sollte.

Bei Mehrfachauswahl (Kombination) anderer Werte erfolgt KEINE grafische Darstellung in der Aktivität.

- **Open questions (chapter "Description"):**

Here you can enter any open questions which are still to be answered for this activity.

If you enter any open questions, a red question mark appears above the object symbol on the drawing area.

Hinterlegen Sie hier eventuell noch vorhandene offene Fragen zu diesem Objekt.

Bei offenen Fragen erscheint auf der Zeichenoberfläche neben dem Objekt ein rotes Fragezeichen.

- **Responsible for execution (chapter "RACI/DEMI"):**

It is possible to reference a role from a working environment model, which is responsible for the realization of the activity.

The reference can be selected or changed by clicking on the add-icon (symbol 'plus').

If a role is entered, a realization responsibility will be displayed as a hyperlink in the visualized reference overview (menu 'View' - menu item 'Views' - sub-menu item 'Visualize/hide reference overview') if the attribute "DEMI-/RACI visibility" (DEMI-/RACI view in menu 'View' - menu item

'Views' - sub-menu item 'Configuration reference overview') in the line "R" (using horizontal modelling direction) or in the column "R" (using vertical modelling direction) is activated.

Referenzieren Sie jene Rolle aus einem Arbeitsumgebungsmodell, welche für die Durchführung der Aktivität verantwortlich ist.

Die Referenz wird über das Hinzufügen-Icon ('Plus'-Symbol) ausgewählt bzw. geändert.

Eine eingetragene Durchführungsverantwortung wird in der eingeblendeten Referenzenübersicht (Menü 'Ansicht' - Menüpunkt 'Sichten' - Untermenüpunkt 'Referenzenübersicht ein/ausblenden') bei aktivierter DEMI-/RACI-Sicht (Menü 'Ansicht' - Menüpunkt 'Sichten' - Untermenüpunkt 'Referenzenübersicht konfigurieren') in der Zeile "D" (bei horizontaler Modellierungsrichtung) bzw. in der Spalte "D" (bei vertikaler Modellierungsrichtung) als Hyperlink angezeigt.

- **Accountable for approving results (chapter "RACI/DEMI"):**

Reference a role from a working environment model, which is accountable for approving results of the activity.

The reference can be selected or changed by the add-icon (symbol 'plus').

If entered, a result responsibility will be displayed as a hyperlink in the visualized reference overview (menu 'View' - menu item 'Views' - sub-menu item 'Visualize/hide reference overview') in case of the activated attribute "DEMI-/RACI Sicht" (DEMI-/RACI view in menu 'View' - menu item 'Views' - sub-menu item 'Configuration reference overview') in the line "A" (using horizontal modelling direction) or in the column "A" (using vertical modelling direction).

Referenzieren Sie jene Rolle aus einem Arbeitsumgebungsmodell, welche für das Ergebnis der Aktivität verantwortlich ist.

Die Referenz wird über das Hinzufügen-Icon ('Plus'-Symbol) ausgewählt bzw. geändert.

Eine eingetragene Ergebnisverantwortung wird in der eingeblendeten Referenzenübersicht (Menü 'Ansicht' - Menüpunkt 'Sichten' - Untermenüpunkt 'Referenzenübersicht ein/ausblenden') bei aktivierter DEMI-/RACI-Sicht (Menü 'Ansicht' - Menüpunkt 'Sichten' - Untermenüpunkt 'Referenzenübersicht konfigurieren') in der Zeile "E" (bei horizontaler Modellierungsrichtung) bzw. in der Spalte "E" (bei vertikaler Modellierungsrichtung) als Hyperlink angezeigt.

- **Cooperation/participation (chapter "RACI/DEMI"):**

Reference roles from a working environment model, which are participating in the realization of the activity.

The reference can be selected or changed by the add-icon (symbol 'plus').

If entered, the role(s) will be displayed as a hyperlink in the visualized reference overview (menu 'View' - menu item 'Views' - sub-menu item 'Visualize/hide reference overview') in case of the activated attribute "DEMI-/RACI Sicht" (DEMI-/RACI view in menu 'View' - menu item 'Views' - sub-menu item 'Configuration reference overview') in the line "C" (using horizontal modelling direction) or in the column "C" (using vertical modelling direction).

Referenzieren Sie jene Rollen aus einem Arbeitsumgebungsmodell, welche bei Erledigung der Aktivität mitarbeiten oder mitwirken.

Die Referenz wird über das Hinzufügen-Icon ('Plus'-Symbol) ausgewählt bzw. geändert.

Eine eingetragene Durchführungsverantwortung wird in der eingeblendeten Referenzenübersicht (Menü 'Ansicht' - Menüpunkt 'Sichten' - Untermenüpunkt 'Referenzenübersicht ein/ausblenden') bei aktivierter DEMI-/RACI-Sicht (Menü 'Ansicht' - Menüpunkt 'Sichten' - Untermenüpunkt 'Referenzenübersicht konfigurieren') in der Zeile "C" (bei horizontaler Modellierungsrichtung) bzw. in der Spalte "C" (bei vertikaler Modellierungsrichtung) als Hyperlink angezeigt.

enzenübersicht konfigurieren") in der Zeile "M" (bei horizontaler Modellierungsrichtung) bzw. in der Spalte "M" (bei vertikaler Modellierungsrichtung) angezeigt.

- **To inform (chapter "RACI/DEMI"):**

Reference roles from a working environment model, which are informed after the realization of the activity.

The reference can be selected or changed by the add-icon (symbol 'plus').

The entered roles which have to be informed will be displayed as a hyperlink in the visualized reference overview (menu 'View' - menu item 'Views' - sub-menu item 'Visualize/hide reference overview') in case of the activated attribute "DEMI-/RACI Sicht" (DEMI-/RACI view in menu 'View' - menu item 'Views' - sub-menu item 'Configuration reference overview') in the line "I" (using horizontal modelling direction) or in the column "I" (using vertical modelling direction).

Referenzieren Sie jene Rollen aus einem Arbeitsumgebungsmodell, welche bei oder nach Erledigung der Aktivität informiert werden.

Die Referenz wird über das Hinzufügen-Icon ('Plus'-Symbol) ausgewählt bzw. geändert.

Die eingetragenen zu informierenden Rollen werden in der eingeblendeten Referenzenübersicht (Menü 'Ansicht' - Menüpunkt 'Sichten' - Untermenüpunkt 'Referenzenübersicht ein/ausblenden') bei aktivierter DEMI-/RACI-Sicht (Menü 'Ansicht' - Menüpunkt 'Sichten' - Untermenüpunkt 'Referenzenübersicht konfigurieren') in der Zeile "I" (bei horizontaler Modellierungsrichtung) bzw. in der Spalte "I" (bei vertikaler Modellierungsrichtung) als Hyperlink angezeigt.

- **Input (chapter "Documents"):**

It is possible to reference documents from a document model, which are used as input for the realization of the activity.

The reference can be selected or changed by clicking on the add-icon (symbol 'plus').

When entered, input documents are displayed by a downward arrow symbol on the left above the activity.

An input document entered will be displayed as a hyperlink in the visualized reference overview (menu 'View' - menu item 'Views' - sub-menu item 'Visualize/hide reference overview') if the attribute "DEMI-/RACI visibility" (DEMI-/RACI view in menu 'View' - menu item 'Views' - sub-menu item 'Configuration reference overview') in the line "In" (using horizontal modelling direction) or in the column "In" (using vertical modelling direction) is activated.

Referenzieren Sie jene Dokumente aus einem Dokumentenmodell, welche Input für die Erledigung der Aktivität sind.

Die Referenz wird über das Hinzufügen-Icon ('Plus'-Symbol) ausgewählt bzw. geändert.

Eingetragene Input-Dokumente werden durch das Symbol eines nach unten gerichteten Pfeils links oberhalb der Aktivität angezeigt.

Die eingetragenen Input-Dokumente werden in der eingeblendeten Referenzenübersicht (Menü 'Ansicht' - Menüpunkt 'Sichten' - Untermenüpunkt 'Referenzenübersicht ein/ausblenden') bei aktivierter Input/Output-Sicht (Menü 'Ansicht' - Menüpunkt 'Sichten' - Untermenüpunkt 'Referenzenübersicht konfigurieren') in der Zeile "In" (bei horizontaler Modellierungsrichtung) bzw. in der Spalte "In" (bei vertikaler Modellierungsrichtung) als Hyperlink angezeigt.

- **Output (chapter "Documents"):**

It is possible to reference documents from a document model, which are used as input for the realization of the activity.

The reference can be selected or changed by clicking on the add-icon (symbol 'plus').

When entered, input documents are displayed by a downward arrow symbol on the left above the activity.

An input document entered will be displayed as a hyperlink in the visualized reference overview (menu 'View' - menu item 'Views' - sub-menu item 'Visualize/hide reference overview') if the attribute "DEMI-/RACI visibility" (DEMI-/RACI view in menu 'View' - menu item 'Views' - sub-menu item 'Configuration reference overview') in the line "In" (using horizontal modelling direction) or in the column "In" (using vertical modelling direction) is activated.

Referenzieren Sie jene Dokumente aus einem Dokumentenmodell, welche Input für die Erledigung der Aktivität sind.

Die Referenz wird über das Hinzufügen-Icon ('Plus'-Symbol) ausgewählt bzw. geändert.

Eingetragene Input-Dokumente werden durch das Symbol eines nach unten gerichteten Pfeils links oberhalb der Aktivität angezeigt.

Die eingetragenen Input-Dokumente werden in der eingeblendeten Referenzenübersicht (Menü 'Ansicht' - Menüpunkt 'Sichten' - Untermenüpunkt 'Referenzenübersicht ein/ausblenden') bei aktivierter Input/Output-Sicht (Menü 'Ansicht' - Menüpunkt 'Sichten' - Untermenüpunkt 'Referenzenübersicht konfigurieren') in der Zeile "In" (bei horizontaler Modellierungsrichtung) bzw. in der Spalte "In" (bei vertikaler Modellierungsrichtung) als Hyperlink angezeigt.

- **Referenced documents (chapter "Documents"):**

It is possible to reference documents from a document model, which are required for the realization of the activity (e.g. connected documents).

The reference can be selected or changed by clicking on the add-icon (symbol 'plus').

When entered, referenced documents are displayed by a document symbol on the right side above the object.

Referenzieren Sie jene Dokumente aus einem Dokumentenmodell, welche für die Erledigung der Aktivität (z.B. mitgeltende Unterlagen) notwendig sind.

Die Referenz wird über das Hinzufügen-Icon ('Plus'-Symbol) ausgewählt bzw. geändert.

Eingetragene referenzierte Dokumente werden durch ein Dokumenten-Symbol rechts oberhalb des Objekts angezeigt.

- **External documentation (chapter "Documents"):**

The attribute "External documentation" allows the integration of existing information sources (documents, tables, graphics, intranet pages...) into the activities of a business process model.

The integration is carried out by entering the path and the file name in the field 'Program arguments'.

When entered, external documents are displayed by a document symbol on the right side above the object.

Die "Externe Dokumentation" ermöglicht die Einbindung von bestehenden Informationsquellen (Dokumente, Tabellen, Grafiken, Intranet-Seiten ...) in die Aktivitäten eines Geschäftsprozeßmodells.

Die Einbindung erfolgt durch das Eintragen des Pfades und des Dateinamens im Feld 'Parameter'.

Eingetragene externe Dokumente werden durch ein Dokumenten-Symbol rechts oberhalb des Objekts angezeigt.

- **Referenced IT system elements (chapter "Systems"):**

It is possible to reference IT system elements (application, service or infrastructure element) from an IT system model, which are required for the realization of the activity.

The reference can be selected or changed by clicking on the add-icon (symbol 'plus').

If a reference is entered, the elements are displayed as a hyperlink above the activity if the option "Visualise referenced IT system elements" is activated.

The IT system elements entered will be displayed as a hyperlink in the visualized reference overview (menu 'View' - menu item 'Views' - sub-menu item 'Visualize/hide reference overview') if the attribute "DEMI-/RACI visibility" (DEMI-/RACI view in menu 'View' - menu item 'Views' - sub-menu item 'Configuration reference overview') in the line "IT" (using horizontal modelling direction) or in the column "IT" (using vertical modelling direction) is activated.

Referenzieren Sie jene IT systemelemente (d.h. Anwendung, Service oder Infrastrukturelement) aus einem IT systemmodell, welche für die Erledigung der Aktivität notwendig sind.

Die Referenz wird über das Hinzufügen-Icon ('Plus'-Symbol) ausgewählt bzw. geändert.

Die eingetragenen IT systemelemente werden oberhalb der Aktivität als Hyperlink angezeigt, wenn die Option "Referenzierte IT systemelemente visualisieren" aktiviert ist.

Die eingetragenen IT systemelemente werden in der eingeblendeten Referenzenübersicht (Menü 'Ansicht' - Menüpunkt 'Sichten' - Untermenüpunkt 'Referenzenübersicht ein/ausblenden') bei aktivierter IT-Systeme-Sicht (Menü 'Ansicht' - Menüpunkt 'Sichten' - Untermenüpunkt 'Referenzenübersicht konfigurieren') in der Zeile "IT" (bei horizontaler Modellierungsrichtung) bzw. in der Spalte "IT" (bei vertikaler Modellierungsrichtung) als Hyperlink angezeigt.

- **Visualise referenced IT system elements (chapter "Systems"):**

- **Referenced use cases (chapter "Systems"):**

It is possible to reference a use case from a use case diagram, in which an IT-supported realization of the activity is described.

The reference can be selected or changed by clicking on the add-icon (symbol 'plus').

The use cases entered will be displayed as a hyperlink in the visualized reference overview (menu 'View' - menu item 'Views' - sub-menu item 'Visualize/hide reference overview') if the attribute "DEMI-/RACI visibility" (DEMI-/RACI view in menu 'View' - menu item 'Views' - sub-menu item 'Configuration reference overview') in the line "UC" (using horizontal modelling direction) or in the column "UC" (using vertical modelling direction) is activated.

Referenzieren Sie jene Anwendungsfälle aus einem Anwendungsfalldiagramm, in welchen eine IT-gestützte Durchführung der Aktivität beschrieben wird.

Die Referenz wird über das Hinzufügen-Icon ('Plus'-Symbol) ausgewählt bzw. geändert.

Die eingetragenen Anwendungsfälle werden in der eingeblendeten Referenzenübersicht (Menü 'Ansicht' - Menüpunkt 'Sichten' - Untermenüpunkt 'Referenzenübersicht ein/ausblenden') bei aktivierter Anwendungsfälle-Sicht (Menü 'Ansicht' - Menüpunkt 'Sichten' - Untermenüpunkt 'Referenzenübersicht konfigurieren') in der Zeile "UC" (bei horizontaler Modellierungsrichtung) bzw. in der Spalte "UC" (bei vertikaler Modellierungsrichtung) als Hyperlink angezeigt.

- **Referenced products (chapter "Products"):**

It is possible to reference products or product elements from a product model, which are concerned by the realization of the activity.

The reference can be selected or changed by clicking on the add-icon (symbol 'plus').

The products or product elements entered will be displayed as a hyperlink in the visualized reference overview (menu 'View' - menu item 'Views' - sub-menu item 'Visualize/hide reference overview') if the attribute "DEMI-/RACI visibility" (DEMI-/RACI view in menu 'View' - menu item 'Views' - sub-menu item 'Configuration reference overview') in the line "P" (using horizontal modelling direction) or in the column "P" (using vertical modelling direction) is activated.

Referenzieren Sie jene Produkte oder Produktelemente aus einem Produktmodell, welche von der Erledigung der Aktivität betroffen sind.

Die Referenz wird über das Hinzufügen-Icon ('Plus'-Symbol) ausgewählt bzw. geändert.

Die eingetragenen Produkte oder Produktelemente werden in der eingblendeten Referenzenübersicht (Menü 'Ansicht' - Menüpunkt 'Sichten' - Untermenüpunkt 'Referenzenübersicht ein/ausblenden') bei aktivierter Produkte-Sicht (Menü 'Ansicht' - Menüpunkt 'Sichten' - Untermenüpunkt 'Referenzenübersicht konfigurieren') in der Zeile "P" (bei horizontaler Modellierungsrichtung) bzw. in der Spalte "P" (bei vertikaler Modellierungsrichtung) als Hyperlink angezeigt.

- **Execution time (chapter "Times/Costs"):**

This is the time taken to actually execute the activity.

The format for time is yy:ddd:hh:mm:ss (years-days-hours-minutes-seconds). The default value for each time field is 00:000:00:00:00, i.e. the value of each time type will be zero in the simulation if no time value is entered.

The value in this field is used in the simulation algorithms.

Zeit, die direkt für die Erledigung der Aktivität benötigt wird.

Das Format für die Eingabe der Zeit ist jj:ttt:hh:mm:ss (Jahre-Tage-Stunden-Minuten-Sekunden). Der Standardwert für jedes Zeitfeld ist 00:000:00:00:00.

Die eingegebenen Werte werden in der Simulation verwendet. Nimmt man keine Eingabe vor, wird mit Zeit=0 gerechnet.

- **Waiting time (chapter "Times/Costs"):**

This is the time between the possible and the actual start of the execution of the activity.

The format for time is yy:ddd:hh:mm:ss (years-days-hours-minutes-seconds). The default value for each time field is 00:000:00:00:00, i.e. the value of each time type will be zero in the simulation, if no time value is entered.

The value in this field is used in the simulation algorithms.

Zeitspanne zwischen möglichem und tatsächlichem Bearbeitungsbeginn der Aktivität.

Das Format für die Eingabe der Zeit ist jj:ttt:hh:mm:ss (Jahre-Tage-Stunden-Minuten-Sekunden). Der Standardwert für jedes Zeitfeld ist 00:000:00:00:00.

Die eingegebenen Werte werden in der Simulation verwendet. Nimmt man keine Eingabe vor, wird mit Zeit=0 gerechnet.

- **Resting time (chapter "Times/Costs"):**

This is the time between the completion of an activity and its transport to the following activity.

The format for time is yy:ddd:hh:mm:ss (years-days-hours-minutes-seconds). The default value for each time field is 00:000:00:00:00, i.e. the value of each time type will be zero in the simulation, if no time value is entered.

The value in this field is used in the simulation algorithms.

Zeit zwischen dem Bearbeitungsende der Aktivität und dem Transport zur nachfolgenden Aktivität.

Das Format für die Eingabe der Zeit ist jj:ttt:hh:mm:ss (Jahre-Tage-Stunden-Minuten-Sekunden). Der Standardwert für jedes Zeitfeld ist 00:000:00:00:00.

Die eingegebenen Werte werden in der Simulation verwendet. Nimmt man keine Eingabe vor, wird mit Zeit=0 gerechnet.

- **Transport time (chapter "Times/Costs"):**

This is the time used for transport to the next activity.

The format for time is yy:ddd:hh:mm:ss (years-days-hours-minutes-seconds). The default value for each time field is 00:000:00:00:00, i.e. the value of each time type will be zero in the simulation, if no time value is entered.

The value in this field is used in the simulation algorithms.

Zeit, die für den Transport zur nachfolgenden Aktivität benötigt wird.

Das Format für die Eingabe der Zeit ist jj:ttt:hh:mm:ss (Jahre-Tage-Stunden-Minuten-Sekunden). Der Standardwert für jedes Zeitfeld ist 00:000:00:00:00.

Die eingegebenen Werte werden in der Simulation verwendet. Nimmt man keine Eingabe vor, wird mit Zeit=0 gerechnet.

- **Costs (chapter "Times/Costs"):**

Enter the costs associated with the execution of the activity.

Geben Sie die Kosten für die Verrichtung der Aktivität an.

- **EDP transaction costs (chapter "Times/Costs"):**

Enter the EDP transaction costs.

This attribute will be evaluated by the process cost analysis.

Geben Sie die EDV-Transaktionskosten an.

Wird bei der Prozeßkostenanalyse ausgewertet.

- **EDP batch costs (chapter "Times/Costs"):**

Enter the EDP batch costs.

This attribute will be evaluated by the process cost analysis.

Geben Sie die EDV-Batch-Kosten an.
Wird bei der Prozeßkostenanalyse ausgewertet.

- **Printing costs (chapter "Times/Costs"):**

Enter the printing costs.
This attribute will be evaluated by the process cost analysis.

Geben Sie die Druckkosten an.
Wird bei der Prozeßkostenanalyse ausgewertet.

- **Postal costs (chapter "Times/Costs"):**

Enter the postal costs.
This attribute will be evaluated by the process cost analysis.

Geben Sie die Versandkosten an.
Wird bei der Prozeßkostenanalyse ausgewertet.

- **Performer (chapter "Working environment"):**

It is possible to assign a performer, that is, a reference between business processes and working environments.

The assigned performer will be used in all activities of the referenced process. In cases where this process references to another process, this performer will also be used in that process unless a new performer is assigned.

At the top right of the field "Performer" you will find a dialogue button which will give assistance in making performer assignments.

The value of this attribute is needed for the simulation.

Apart from the static elements of AQL, the dynamic elements of "performer of" and "done by" can also be used in the Capacity and Workload analysis.

"performer of": process intern, syntax: performer of <Activity>

The result is the performer of the working environment model, who executed the activity during simulation.

In this way it is ensured that an activity will be executed by the same performer that was assigned in the performer field.

Example: performer of "Contract be filed"

"done by": process interreferenced, syntax: done by <Variable>

The result is the performer of the working environment model, who executes the activity during simulation, at which the variable refers to. To use this construction the name of the variable of the referred activity should be entered in the "done by" attribute.

Example: done by "Contract performer"

Sie können eine "Bearbeiterzuordnung" (eine Verknüpfung von Geschäftsprozessen und Arbeitsumgebungen) vornehmen.

Der hier eingetragene Bearbeiter wird im aufgerufenen Prozeß in allen Aktivitäten verwendet. Ruft dieser Prozeß wieder Prozesse auf, so gilt der Bearbeiter auch für diese, wenn in den Aktivitäten keine weitere Bearbeiterzuordnung eingetragen ist.

Rechts über dem Feld "Bearbeiter" befindet sich ein Button für die Eingabehilfe.

Der Wert dieses Attributs wird für die Simulation benötigt.

Neben den statischen Elementen von AQL können zur Bearbeiterzuordnung insbesondere die beiden dynamischen Konstrukte "hat erledigt" und "erledigt durch" in der Be- und Auslastungsanalyse eingesetzt werden.

"hat erledigt": prozeßintern; Syntax: hat erledigt <Aktivität>

Das Ergebnis ist jener Bearbeiter aus dem Arbeitsumgebungsmodell, der die Aktivität während eines Simulationslaufs ausgeführt hat.

Damit wird gewährleistet, daß die Aktivität vom selben Bearbeiter ausgeführt wird, wie die in der Bearbeiterzuordnung referenzierte Aktivität (nützlich, wenn z.B. in einer Abteilung mehrere Bearbeiter sitzen, aber nur jeweils einer von ihnen einen kompletten Ablauf durchführt).

Beispiel: hat erledigt "Vertrag ablegen"

"erledigt durch": prozeßübergreifend; Syntax: erledigt durch <Variable>

Das Ergebnis ist jener Bearbeiter aus dem Arbeitsumgebungsmodell, der die durch diese Variable referenzierte Aktivität während eines Simulationslaufs ausgeführt hat. Zur Verwendung dieses Konstrukts ist es allerdings nötig, im Attribut 'Erledigt durch' der referenzierten Aktivität den Namen der Variablen einzutragen.

Beispiel: erledigt durch "Vertragsbearbeiter"

- **Continuous execution (chapter "Working environment"):**

When the Continuous execution is activated (value= yes) it means this activity will be executed by the same performer (if possible) as the previous activity.

This activity will be placed at the top of the list of orders that should be executed by the performer, so that execution by the performer is secured in order to avoid any unrealistic waiting times.

Hint: The 'Continuous execution' is only evaluated by the simulation algorithm 'Workload Analysis'.

Ist die "Durchgehende Bearbeitung" aktiviert Wert=ja, wird diese Aktivität sofern grundsätzlich möglich vom gleichen Bearbeiter durchgeführt wie die vorangegangene Aktivität.

Außerdem wird die Aktivität an den Anfang des Auftragsstapels der von einem Bearbeiter zu erledigenden Aufträge eingeordnet, um eine sofortige Bearbeitung dieser Aktivität durch den Bearbeiter sicherzustellen und dadurch unrealistische Wartezeiten auszuschließen.

Hinweis: Die "Durchgehende Bearbeitung" wird nur in der Auslastungsanalyse ausgewertet.

- **Execution interruptable (chapter "Working environment"):**

If an activity is set as 'Execution interruptable' (Value: 'yes') then the execution of the process can be interrupted if the working time for the performer has ended (i.e. end of day etc.).

If the activity is not set as 'Execution interruptable' the process will continue until it is finished (i.e. in the performers free time).

Hint: This attribute is evaluated only in the Workload Analysis.

Wenn die "Bearbeitung unterbrechbar" ist (Wert=ja), wird der Prozeß bei dieser Aktivität unterbrochen, falls die Arbeitszeit des zuständigen Bearbeiters endet.

Wenn die Bearbeitung nicht unterbrechbar ist, wird sie auch in der Freizeit des Bearbeiters fortgesetzt.

Hinweis: Dieses Attribut wird nur in der Auslastungsanalyse ausgewertet.

- **Task stack (chapter "Working environment"):**

Choose 'personal' when the activity is to be executed directly by a specific performer.

If the performer is not available during simulations, the activity remains in the performer's task stack until he executes it.

Choose 'global' when the activity may be executed by the next free performer (not designated to a specific performer). Only available performers may execute activities during simulations.

Hint: This attribute is evaluated only in the Workload Analysis

Wählen Sie "persönlich", wenn die Aktivität einem zuständigen Bearbeiter direkt zugeteilt wird. Die Zuteilung erfolgt auch dann, wenn der Bearbeiter gerade nicht anwesend ist. Die Aktivität verbleibt im Wartestapel dieses Bearbeiters, bis dieser sie durchgeführt hat.

Wählen Sie "zentral", wenn die Aktivität durch den nächsten zuständigen Bearbeiter, der Zeit hat, aufgenommen werden soll. Nur anwesende Bearbeiter können Aktivitäten aufnehmen.

Hinweis: Dieses Attribut wird nur in der Auslastungsanalyse ausgewertet.

- **Done by (chapter "Working environment"):**

By entering a variable name into this attribute, the name of the performer who executes the activity will be saved. Through the "done by" construct it is possible to refer to this variable during execution of interreference AQL expression (Capacity and Workload analysis).

Example:

Assign in the "Done by" field: Application performer

The reference to the Application performer in an AQL expression: done by "Application performer"

Geben Sie den Namen für einen "Merker" an, in dem der Bearbeiter eingetragen wird, der die Aktivität ausgeführt hat. Bei prozeßübergreifenden AQL-Anfragen bezüglich des Bearbeiters einer Aktivität kann hierauf mit dem "erledigt durch"-Konstrukt referenziert werden (Be- und Auslastungsanalyse).

Beispiel:

Eintrag im "Erledigt durch"-Feld: Antragbearbeiter

Referenzierung auf den Antragbearbeiter innerhalb eines AQL-Ausdrucks: erledigt durch "Antragbearbeiter"

- **Cooperative (chapter "Other simulation data"):**

An activity is co-operative (value: yes) when more than one performer, out of potential performers, is chosen to execute it, when the activity is delegated to all potential performers.

The execution of the activity by the performers starts when enough performers are available (see 'Average number of participants' and 'Max start period'). The execution of an activity by the performers may be either synchronous which means that all performers must execute it at the same time or asynchronous where there is a time slack (see 'Cooperation mode').

 Ist eine Aktivität als kooperativ gekennzeichnet (Wert=ja), wird bei der Bearbeiterzuordnung nicht nur genau ein Bearbeiter aus der Menge der potentiellen Bearbeiter ausgewählt, sondern die Aktivität wird an alle potentiellen Bearbeiter delegiert.

Die Ausführung der Aktivität durch die Bearbeiter wird begonnen, sobald genügend Bearbeiter zur Verfügung stehen (siehe "Durchschnittl. Teilnehmerzahl" und "Max. Startzeitraum"). Eine Aktivität kann sowohl synchron, d.h. zeitgleich, als auch asynchron, d.h. zeitversetzt, von den Bearbeitern verrichtet werden (siehe "Kooperationsart").

- **Cooperation mode (chapter "Other simulation data"):**

A synchronous activity (value: synchron) is executed by all performers to whom the activity has been delegated at the same time (see 'Average number of participants' and 'Min. quota of presence').

An asynchronous executed activity (value: asynchron), is executed by all performers with the time slack, i.e. as soon as one performer is available for the execution of the delegated activity.

 Eine synchron bearbeitete Aktivität (Wert=synchron) wird von allen Bearbeitern, an die die Aktivität delegiert wurde, gleichzeitig erledigt (siehe "Durchschnittl. Teilnehmerzahl" und "Min. Anwesenheitsquote").

Asynchron bearbeitete Aktivitäten (Wert=asynchron) werden von allen Bearbeitern, an die die Aktivitäten delegiert wurden, zeitversetzt erledigt, d.h. sobald ein Bearbeiter zur Erledigung der Aktivität zur Verfügung steht, beginnt er mit der Bearbeitung.

- **Average number of participants (chapter "Other simulation data"):**

This attribute is evaluated by the simulation algorithm 'Path Analysis' during the execution of cooperative activities.

During path analysis, activities are not assigned to specific performers.

Therefore a co-operative activity is doubled during analysis by the 'Average number of participants' and these are then executed like parallel activities.

 Dieses Attribut wird bei der Bearbeitung von kooperativen Aktivitäten in der "Pfadanalyse" ausgewertet.

In der Pfadanalyse werden Aktivitäten nicht an konkrete Bearbeiter delegiert.

Eine kooperative Aktivität in der Pfadanalyse wird in Abhängigkeit des Werts des Attributs "Durchschnittl. Teilnehmerzahl" "dupliziert" und analog wie parallele Aktivitäten abgearbeitet.

- **Min. quota of presence (chapter "Other simulation data"):**

This attribute is evaluated during the execution of the co-operative activities by the simulation algorithm 'Workload Analysis'.

It refers to the minimum number of performers who must be present before a synchronous, cooperative activity can be executed.

If a sufficient number of performers are not available, the activity is delayed until they become available. The maximum time delay period is held in the attribute 'Max start period'.

Dieses Attribut wird bei der Bearbeitung von kooperativen Aktivitäten ausgewertet (in der Auslastungsanalyse).

Die minimale Anwesenheitsquote gibt an, wieviele Bearbeiter einer synchronen Aktivität gleichzeitig anwesend sein müssen, damit sie ausgeführt werden kann.

Sind nicht genügend Bearbeiter vorhanden, so wird die Abarbeitung der Aktivität solange verzögert, bis ausreichend viele Bearbeiter anwesend sind. Der Maximalwert der Verzögerung ist "Max. Startzeitraum".

- **Max. start period (chapter "Other simulation data"):**

This attribute is evaluated during the execution of the co-operative activities by the simulation algorithm 'Workload Analysis'.

The value of the 'Max. start period' attribute indicates the maximum length of time for which a co-operative activity may not be executed until a sufficient number of performers is available (see 'Min. quota of presence').

Dieses Attribut wird bei der Bearbeitung von kooperativen Aktivitäten ausgewertet (in der Auslastungsanalyse).

Der Wert von "Max. Startzeitraum" gibt die maximale Zeitdauer an, die eine kooperative Aktivität blockiert wird, bis eine zur Erledigung ausreichende Menge von Bearbeitern anwesend ist (siehe "Min. Anwesenheitsquote").

- **Priority (chapter "Other simulation data"):**

Enter the priority for the activity to be executed.

The higher the value of this attribute, the higher the activity's priority. The execution of activity's in the simulation is done according to the priority. Activities in the same priority are worked out in delivery order.

Geben Sie die Priorität für die Verrichtung der Aktivität an.

Je größer der Wert dieses Attributs ist, desto höher ist die Priorität der Aktivität. Die Erledigung der Aktivitäten in der Simulation erfolgt nach Priorität. Aktivitäten mit gleicher Priorität werden in der Reihenfolge ihrer Ankunft abgearbeitet.

- **Max. resource waiting time (chapter "Other simulation data"):**

The maximum resource waiting time declares the resource waiting time period for which a performer waits until the necessary resources to become available.

If the resource waiting time is greater than declared, the performer will reassign the activity within the task stack.

Example:

If the value of this attribute is: 00:000:00:05:00,

it means that the performer of this task will wait a maximum of 5 minutes for the necessary resource to become available. This task will then be attempted again when the following task has been completed.

Die "maximale Ressourcenwartezeit" gibt jene Zeitspanne an, die der Bearbeiter einer Aktivität maximal wartet, um den Zugriff auf eine Ressource zu bekommen, die zur Erledigung der Aktivität benötigt wird.

Muß der Bearbeiter länger als die angegebene Zeit warten, so stellt er die gerade zu bearbeitende Aktivität in seinen Aktivitätsstapel zurück und beginnt mit der Bearbeitung der im Wartestapel folgenden Aktivität.

Beispiel:

Eintrag im Attribut "max. Ressourcenwartezeit": 00:000:00:05:00.

Der Bearbeiter der Aktivität wartet maximal fünf Minuten zur Erlangung der zur Ausführung der Aktivität benötigten Ressource(n). Falls die Summe der Bearbeitungszeiten der auf die Ressource wartenden Aktivitäten größer als fünf Minuten ist, führt der Bearbeiter die nächste ihm zugeordnete Aktivität aus und stellt die derzeitige Aktivität zurück in seinen Wartestapel. Hat der Bearbeiter die nächste Aktivität ausgeführt, so versucht er die zurückgestellte Aktivität zu erledigen.

- **Number (chapter "Simulation results"):**

The number contains the number of times this activity was executed concerning the last evaluation carried out.

Die Anzahl enthält die Häufigkeit des Auftretens der Aktivität bezüglich der zuletzt durchgeführten Auswertung.

- **Aggregated execution time (chapter "Simulation results"):**

The value of this attribute contains an estimation of the expected value for the execution time of the business process.

More information can be found in the attribute 'Info on results'.

Dieses Attribut enthält die gesamte Bearbeitungszeit einer Aktivität (entweder bezogen auf ein Jahr oder einen einzelnen Geschäftsprozeß).

Nähere Informationen zum Bezugszeitraum finden Sie im Attribut "Ergebnisinfo".

- **Aggregated waiting time (chapter "Simulation results"):**

The value of this attribute contains an estimation of the expected value for the waiting time of the business process.

More information can be found in the attribute 'Info on results'.

Dieses Attribut enthält die gesamte Wartezeit einer Aktivität (entweder bezogen auf ein Jahr oder einen einzelnen Geschäftsprozeß).

Nähere Informationen zum Bezugszeitraum finden Sie im Attribut "Ergebnisinfo".

- **Aggregated resting time (chapter "Simulation results"):**

The value of this attribute contains an estimation of the expected value for the resting time of the of the business-process.

More information about the relevant period can be found in the attribute 'Info on results'.

Dieses Attribut enthält die gesamte Liegezeit einer Aktivität (entweder bezogen auf ein Jahr oder einen einzelnen Geschäftsprozeß).

Nähere Informationen zum Bezugszeitraum finden Sie im Attribut "Ergebnisinfo".

- **Aggregated transport time (chapter "Simulation results"):**

The value of this attribute contains an estimation of the expected value for the transport time of the business-process.

More information about the relevant period can be found in the attribute 'Info on results'.

Dieses Attribut enthält die gesamte Transportzeit einer Aktivität (entweder bezogen auf ein Jahr oder einen einzelnen Geschäftsprozeß).

Nähere Informationen zum Bezugszeitraum finden Sie im Attribut "Ergebnisinfo".

- **Aggregated costs (chapter "Simulation results"):**

The value of this attribute contains an estimation of the expected activity-costs for this business process.

More information about the relevant period can be found in the attribute 'Info on result'.

Dieses Attribut enthält die gesamten Aktivitätskosten (entweder bezogen auf ein Jahr oder einen einzelnen Geschäftsprozeß).

Nähere Informationen zum Bezugszeitraum finden Sie im Attribut "Ergebnisinfo".

- **Aggregated personnel costs (chapter "Simulation results"):**

The value of this attribute contains an estimator for the expected value of the personnel costs of the business process.

More information about the relevant period can be found in the attribute 'Info on results'.

Dieses Attribut enthält die gesamten Personalkosten einer Aktivität (entweder bezogen auf ein Jahr oder einen einzelnen Geschäftsprozeß).

Nähere Informationen zum Bezugszeitraum finden Sie im Attribut "Ergebnisinfo".

- **Info on results (chapter "Simulation results"):**

The value of this attribute gives more information about the last evaluation carried out.

Der Wert dieses Attributs liefert nähere Informationen zu jener zuletzt durchgeführten Auswertung, deren Ergebnisse in das Modell übernommen wurden.

- **Bezeichnung (chapter "Deutsch"):**

Geben Sie die Bezeichnung der Aktivität ein. Dient der Dokumentation.

- **Beschreibung (chapter "Deutsch"):**

Geben Sie eine charakterisierende Beschreibung der Aktivität an.

Dient der Dokumentation.

Describe the characteristics of the activity.

The description will be used for documentation purposes.

- **Kommentar (chapter "Deutsch"):**

Geben Sie einen Kommentar zur Aktivität an.

Dient der Dokumentation.

Enter any comments about the object.

The comments will be used for documentation purposes.

2.8 Class "Decision"



The decision object within a business process model allows pre-defined variables to be queried in order to determine the path through the process.

A decision has at least one predecessor and at least two Subsequent relations.

During a simulation only one of the Subsequents must evaluate to "true".

During the analytical evaluation, the subsequent connectors of the decisions have to be set with a transition probability, where the sum of all transition probabilities of the subsequent connectors outgoing from a decision object must always be (1).

If the sum of all transition probabilities of the subsequent connectors outgoing from a decision object is not (1), it will be displayed in the graphical representation with a red '!' (on the right above the decision object) meaning that no analytical evaluation is possible.

Die Klasse "Entscheidung" ermöglicht die Abfrage bereits definierter Variablen und eine entsprechende Entscheidung für einen Pfad, wobei aber eine Entscheidung während eines Durchlaufs nur einen Nachfolger haben kann.

Das Objekt "Entscheidung" hat mindestens einen Vorgänger und mindestens zwei Nachfolger.

Bei der Simulation des Geschäftsprozesses muß nach einer Entscheidung genau eine Nachfolger-Beziehung möglich sein, d.h. ein korrekter Wert im Attribut "Übergangsbedingung" der ausgehenden "Nachfolger"-Konnektoren.

Bei rechnerischer Auswertung müssen von Entscheidungen wegführende Nachfolger-Konnektoren mit Übergangswahrscheinlichkeiten belegt werden, wobei die Summe aller Übergangswahrscheinlichkeiten der von einer Entscheidung ausgehenden Nachfolger immer eins (1) ergeben muß.

Ist neben einer Entscheidung ein rotes Rufzeichen abgebildet, so ist keine rechnerische Auswertung des Modells möglich, da die Summe der Wahrscheinlichkeiten in den Nachfolgerkonnektoren ungleich 1 ist.

The following attributes are defined for the class "Decision":

- **Name (chapter "Description"):**

- **Order (chapter "Description"):**

This attribute can be set with the help of the 'Object numbering' function, which numbers the objects of the business process model.

This can be useful for example within the component 'Documentation', to ensure that all objects are documented in the required order.

Dieses Attribut kann mit Hilfe der Numerierungsfunktion, mit der die Objekte des Geschäftsprozeßmodells numeriert werden, belegt werden.

Die Reihenfolge wird beispielsweise bei Verwendung der Zusatzkomponente "Dokumentationskomponente" herangezogen, um die Objekte in gewünschter Abfolge zu dokumentieren.

- **Description (chapter "Description"):**

Describe the characteristics of the decision.

The description will be used for documentation purposes.

Geben Sie eine charakterisierende Beschreibung der Entscheidung an.

Dient der Dokumentation.

- **Comment (chapter "Description"):**

Enter any comments about the decision.

The comments will be used for documentation purposes.

Geben Sie einen Kommentar zur Entscheidung an.

Dient der Dokumentation.

- **Open questions (chapter "Description"):**

Here you can enter any open questions which are still to be answered for this decision.

If you enter any open questions, a red question mark appears above the object symbol on the drawing area.

Hinterlegen Sie hier eventuell noch vorhandene offene Fragen zu diesem Objekt.

Bei offenen Fragen erscheint auf der Zeichenoberfläche neben dem Objekt ein rotes Fragezeichen.

- **Bezeichnung (chapter "Deutsch"):**

Geben Sie eine Bezeichnung der Entscheidung ein. Dient der Dokumentation.

- **Beschreibung (chapter "Deutsch"):**

Geben Sie eine Beschreibung der Entscheidung ein. Dient der Dokumentation.

Describe the characteristics of the decision.

The description will be used for documentation purposes.

- **Kommentar (chapter "Deutsch"):**

Geben Sie einen Kommentar zur Entscheidung an.

Dient der Dokumentation.

Enter any comments about the decision.

The comments will be used for documentation purposes.

2.9 Class "Parallelity"



The parallelity makes it possible for several paths in a business process to be executed at the same time. Every parallelity ends with a union (Merging object).

The object parallelity has at least one predecessor and one subsequent relation. A transition condition can be set on a subsequent relation following a parallelity object. This means that one (or more) of the "parallel" paths may be followed only in certain conditions.

The object "parallelity" should have the same number of Subsequents as the corresponding "Merging" object has predecessors. The only exception allowed is when a "Decision" splits a path into two or more (logical) paths. The requirement of the parallelity is fulfilled if only one single path leads on after the decision. Only the paths which started from the object "Parallelity" may lead to the corresponding object "Merging", no more.

The name of a parallelity can be visualized if required by changing the "Representation" attribute in the Notebook.

Die Parallelität ermöglicht, mehrere Pfade in einem Geschäftsprozeßmodell gleichzeitig zu durchlaufen.

Part III

Durch die Parallelität können voneinander unabhängige Teile des Geschäftsprozesses gleichzeitig abgearbeitet werden. Durch eine Vereinigung wird sie beendet.

Das Objekt "Parallelität" hat mindestens einen Vorgänger und mindestens zwei Nachfolger. Den Nachfolgern kann eine Übergangsbedingung zugeordnet werden, um zeitlich unabhängige Pfade an eine Entscheidung zu koppeln.

Das Objekt "Parallelität" sollte grundsätzlich genauso viele Nachfolger haben wie das zugehörige Objekt "Vereinigung" Vorgänger. Die einzige zulässige Ausnahme ist, daß durch eine Entscheidung ein Pfad in zwei oder mehrere (logische) Pfade aufgespalten wird. Es dürfen dementsprechend in die Vereinigung nur genausoviele Pfade führen wie die Parallelität verlassen haben.

Der Name der Parallelität kann durch entsprechende Einstellung des Attributs "Darstellung" auf der grafischen Oberfläche abgebildet werden.

The following attributes are defined for the class "Parallellity":

- **Name (chapter "Description"):**

- **Representation (chapter "Description"):**

It is possible to choose whether the name of the parallelity should be visualized.

Geben Sie an, ob der Name der Parallelität auf der grafischen Oberfläche dargestellt werden soll oder nicht.

- **Modeling direction (chapter "Description"):**

- **Change modelling direction (global) (chapter "Description"):**

- **Order (chapter "Description"):**

This attribute can be set with the help of the 'Object numbering' function, which numbers the objects of the business process model.

This can be useful for example within the component 'Documentation', to ensure that all objects are documented in the required order.

Dieses Attribut kann mit Hilfe der Numerierungsfunktion, mit der die Objekte des Geschäftsprozeßmodells numeriert werden, belegt werden.

Die Reihenfolge wird beispielsweise bei Verwendung der Zusatzkomponente "Dokumentationskomponente" herangezogen, um die Objekte in gewünschter Abfolge zu dokumentieren.

- **Description (chapter "Description"):**

Describe the characteristics of the parallelity.

The description will be used for documentation purposes.

Geben Sie eine charakterisierende Beschreibung der Parallelität ein.

Dient der Dokumentation.

- **Comment (chapter "Description"):**

Enter any comments about the parallelity.

The comments will be used for documentation purposes.

Geben Sie einen Kommentar zur Parallelität ein.

Dient der Dokumentation.

- **Bezeichnung (chapter "Deutsch"):**

Geben Sie eine Bezeichnung der Parallelität ein. Dient der Dokumentation.

- **Beschreibung (chapter "Deutsch"):**

Geben Sie eine charakterisierende Beschreibung der Parallelität ein.

Dient der Dokumentation.

Describe the characteristics of the object.

The description will be used for documentation purposes.

- **Kommentar (chapter "Deutsch"):**

Geben Sie einen Kommentar zur Parallelität ein.

Dient der Dokumentation.

Enter any comments about the object.

The comments will be used for documentation purposes.

2.10 Class "Merging"



The "Merging" object re-joins parallel paths.

The object "Merging" has the same amount of predecessors as the corresponding object "Parallelity" has Subsequents, and it has at most one subsequent relation. The only exception allowed is when a "Decision" splits a path into two or more (logical) paths. Only the paths which started from the object "Parallelity" may lead to the corresponding object "Merging", no more.

Part III

The name of a Merging can be visualized if preferred by changing the "Representation" attribute in the Notebook.

Mit dem Objekt "Vereinigung" werden parallele Pfade wieder zusammengeführt.

Die Vereinigung hat genauso viele Vorgänger wie die zugehörige Parallelität Nachfolger hat und besitzt maximal einen Nachfolger. Die einzige zulässige Ausnahme ist, daß durch eine Entscheidung ein Pfad in zwei oder mehrere (logische) Pfade aufgespalten wurde. Es dürfen dementsprechend in die Vereinigung nur genausoviele Pfade führen wie die Parallelität verlassen haben.

Der Name der Vereinigung kann durch entsprechende Einstellung des Attributes 'Darstellung' auf der grafischen Oberfläche abgebildet werden.

The following attributes are defined for the class "Merging":

- **Name (chapter "Description"):**

- **Representation (chapter "Description"):**

Select whether the name should be displayed on the drawing area.

Geben Sie an, ob der Name der Vereinigung auf der grafischen Oberfläche angezeigt werden soll.

- **Change modelling direction (global) (chapter "Description"):**

- **Order (chapter "Description"):**

This attribute can be set with the help of the 'Object numbering' function, which numbers the objects of the business process model.

This can be useful for example within the component 'Documentation', to ensure that all objects are documented in the required order.

Dieses Attribut kann mit Hilfe der Numerierungsfunktion, mit der die Objekte des Geschäftsprozeßmodells numeriert werden, belegt werden.

Die Reihenfolge wird beispielsweise bei Verwendung der Zusatzkomponente "Dokumentationskomponente" herangezogen werden, um die Objekte in gewünschter Abfolge zu dokumentieren.

- **Description (chapter "Description"):**

Describe the characteristics of the object.

The description will be used for documentation purposes.

Geben Sie eine charakterisierende Beschreibung der Vereinigung ein.

Dient der Dokumentation.

- **Comment (chapter "Description"):**

Enter any comments about the object.

The comments will be used for documentation purposes.

Geben Sie einen Kommentar zur Vereinigung ein.

Dient der Dokumentation.

- **Bezeichnung (chapter "Deutsch"):**

Geben Sie eine Bezeichnung der Vereinigung ein. Dient der Dokumentation.

- **Beschreibung (chapter "Deutsch"):**

Geben Sie eine charakterisierende Beschreibung der Vereinigung ein.

Dient der Dokumentation.

Describe the characteristics of the object.

The description will be used for documentation purposes.

- **Kommentar (chapter "Deutsch"):**

Geben Sie einen Kommentar zur Vereinigung ein.

Dient der Dokumentation.

Enter any comments about the object.

The comments will be used for documentation purposes.

2.11 Class "End"



The object 'End' marks the end of a path in a business process. Several objects of the class 'End' are allowed in one model.

The object 'End' has at least one predecessor and no Subsequent.

The name of the end-object can be visualized by changing the attribute 'Representation'.

Das Objekt "Ende" kennzeichnet das Ende eines Pfads eines Geschäftsprozesses. Es können in einem Modell mehrere Objekte der Klasse "Ende" vorhanden sein.

Das Objekt "Ende" hat mindestens einen Vorgänger und keinen Nachfolger.

Der Name des Ende-Objekts kann durch entsprechende Einstellung des Attributs "Darstellung" visualisiert werden.

The following attributes are defined for the class "End":

- **Name (chapter "Description"):**

- **Representation (chapter "Description"):**

Select whether the name of the End object should be displayed.

Geben Sie an, ob der Name des Objekts "Ende" auf der grafischen Oberfläche dargestellt werden soll oder nicht.

- **Order (chapter "Description"):**

This attribute can be set with the help of the 'Object numbering' function, which numbers the objects of the business process model.

This can be useful for example within the component 'Documentation', to ensure that all objects are documented in the required order.

Dieses Attribut kann mit Hilfe der Numerierungsfunktion, mit der die Objekte des Geschäftsprozeßmodells numeriert werden, belegt werden.

Die Reihenfolge wird beispielsweise bei Verwendung der Zusatzkomponente "Dokumentationskomponente" herangezogen, um die Objekte in gewünschter Abfolge zu dokumentieren.

- **Type (chapter "Description"):**

A local end indicates the end of the current business process and the return to the business process that called it. The path will then follow on from there.

A global end indicates the end of the current business process and the return to the business process that called it. However the path in the process that called it is now interrupted and returns to the process that called it... and so on... until the entire process ends. If a global end occurs inside a parallelity, then the path continues until the corresponding merging and then the process ends as described above.

Ein lokales Ende bewirkt die Beendigung des aktuellen Geschäftsprozesses und den Rücksprung zum aufrufenden Geschäftsprozeß. Die Pfadabarbeitung wird im aufrufenden Prozeß fortgesetzt.

Ein globales Ende bewirkt die Beendigung des aktuellen Geschäftsprozesses und (ggf.) den Rücksprung zum aufrufenden Geschäftsprozeß. Die Pfadabarbeitung wird im aufrufenden Prozeß aber nicht fortgesetzt, sondern ebenfalls abgebrochen und (ggf.) zum aufrufenden Geschäftsprozeß zurückgesprungen usw.

Wird ein globales Ende innerhalb einer Parallelität erreicht, wird in den parallelen Pfaden die Pfadabarbeitung bis zur Vereinigung fortgesetzt. Nach der Vereinigung wird ein Abbruch der Prozeßabarbeitung (wie oben beschrieben) vorgenommen.

- **Description (chapter "Description"):**

Describe the characteristics of the end object.

The description will be used for documentation purposes.

Geben Sie eine charakterisierende Beschreibung ein.
Dient der Dokumentation.

- **Comment (chapter "Description"):**

Enter any comments about the end object.
The comments will be used for documentation purposes.

Geben Sie einen Kommentar ein.
Dient der Dokumentation.

- **Bezeichnung (chapter "Deutsch"):**

Geben Sie eine Bezeichnung des Endes ein. Dient der Dokumentation.

- **Beschreibung (chapter "Deutsch"):**

Geben Sie eine charakterisierende Beschreibung ein.
Dient der Dokumentation.

Describe the characteristics of the object.
The description will be used for documentation purposes.

- **Kommentar (chapter "Deutsch"):**

Geben Sie einen Kommentar ein.
Dient der Dokumentation.

Enter any comments about the object.
The comments will be used for documentation purposes.

2.12 Class "Variable"



Variables are used to define transition conditions in the model.

These transition conditions are set in the 'Subsequent' relation (after a Decision or Parallelity). The object 'Variable' has no predecessor or Subsequent relation. It can be related to the object 'Random generator' with the relation 'Sets variable'.

One variable can be set with different values at different times through the use of several 'Random generators'.

Variablen werden verwendet, um Übergangsbedingungen im Modell zu definieren.

Diese werden in den Beziehungen "Nachfolger" (nach einer Entscheidung oder Parallelität) festgelegt. Das Objekt "Variable" hat weder einen Vorgänger noch einen Nachfolger. Es steht in Beziehung zum Objekt "Variablenbelegung" über die Beziehung "belegt Variable".

Eine Variable kann von mehreren Objekten "Variablenbelegung" zu unterschiedlichen Zeiten mit unterschiedlichen Werten belegt werden.

The following attributes are defined for the class "Variable":

- **Name (chapter "Description"):**

- **Description (chapter "Description"):**

Describe the characteristics of the variable.

The description will be used for documentation purposes.

Geben Sie eine Charakterisierung der Variablen ein.

Dient der Dokumentation.

- **Comment (chapter "Description"):**

Enter any comments about the variable.

The comments will be used for documentation purposes.

Geben Sie einen Kommentar zur Variablen an.

Dient der Dokumentation.

- **Variable type (chapter "Description"):**

Select the variable type 'float' if the value of the variable should be defined using normals, exponential or uniform distribution and the variable type 'enumeration' when the value is defined by discrete distribution.

It is important to select the correct type as errors may occur during simulation if the wrong one is selected!

 Wählen Sie den Variablentyp

- "Gleitkommazahl", wenn die Variable mittels Normal-, Exponential- oder Gleichverteilung belegt wird,

- "Aufzählung", wenn Sie die Variable mit dem Wert aus einer diskreten Verteilung belegen wollen.

Achten Sie auf die richtige Zuordnung, da andernfalls keine Simulation durchgeführt werden kann!

- **Variable scope (chapter "Description"):**

The scope of a variable may be either local or global. A local variable may only be referred to in the model in which it was defined.

A global variable may be referenced anywhere within the related model structure i.e. in any sub-processes or parent processes of the model in which it was defined.

A local variable may however be passed as a parameter to a subprocess.

 Der Geltungsbereich der Variablen kann lokal oder global sein.

Eine lokale Variable kann nur in jenem Modell referenziert werden, in dem sie belegt wurde. Eine globale Variable kann auch in einem Subprozeß belegt und im Hauptprozeß referenziert werden (und umgekehrt).

Allerdings können lokale Variablen an einen Subprozeß übergeben werden.

- **Bezeichnung (chapter "Deutsch"):**

Geben Sie eine Bezeichnung der Variable ein. Dient der Dokumentation.

- **Beschreibung (chapter "Deutsch"):**

Geben Sie eine Charakterisierung der Variablen ein.

Dient der Dokumentation.

 Describe the characteristics of the variable.

The description will be used for documentation purposes.

- **Kommentar (chapter "Deutsch"):**

Geben Sie einen Kommentar zur Variablen an.

Dient der Dokumentation.

 Enter any comments about the variable.

The comments will be used for documentation purposes.

2.13 Class "Random generator"



The Random generator sets a variable with a certain value. The value can be set through a steady or a discrete distribution function. The object 'Random generator' has no predecessor or subsequent relations.

The object 'Random generator' can be related to the following objects:

- 'Variable' through the relation 'Sets variable'
- 'Process start', 'Activity' through the relation 'Sets'.

It can also be related to other objects such as 'Decision', 'Parallelity' etc through the relation 'Sets'.

Several Random generators can set the same 'Variable' object with values.

Die Variablenbelegung dient dazu, eine Variable mit einem bestimmten Wert zu belegen. Die Belegung kann durch eine stetige oder diskrete Verteilungsfunktion erfolgen.

Das Objekt "Variablenbelegung" hat weder einen Vorgänger noch einen Nachfolger. Es steht in Beziehung zu folgenden Objekten:

- "Variable" über die Beziehung "belegt Variable"
- "Prozeßstart" und "Aktivität" über die Beziehung "belegt"

Es können mehrere Variablenbelegungen einem Objekt "Variable" Werte zuordnen.

The following attributes are defined for the class "Random generator":

- **Value (chapter "Description"):**

Select the type of distribution and the corresponding parameters.

The syntax for entering a continuous distribution is:

- for normal distribution: Normal(<Number 1> ; <Number 2>)

Enter the expectancy and the standard deviation for the normal distribution

Example: Normal(1200; 100) - the variable has a normal distribution with an expected value of 1200 and a standard deviation of 100.

- for exponential distribution: Exponential(<Number>)

Enter the expected value for the exponential distribution where <Number> corresponds to 1 divided by the expectancy (1/E).

Example: Exponential(0.002) - the value is distributed exponentially with the expectancy of 500.

- for uniform distribution: Uniform (<Number1> ; <Number2>)

Enter the boundaries for the normal distribution where Number1 is the lower boundary and Number2 the upper

Example: Equal(0;100) - the variable is distributed uniformly between the boundaries of 0 and 100.

- for discrete distribution: Discrete(<Symbol1> <Number1>; <Symbol2> <Number2> ;...)

You can define one or more symbols with their probabilities of occurrence (Number1, Number2, ...).

Note the sum of all the probabilities for a discrete distribution must be 1!

Example: Discrete(YES 0.6; NO 0.4) - the variable is assigned with the value 'YES' with a probability of 0.6, and NO with a probability of 0.4.

Note the transition conditions are defined as follows <Variable name>='YES' or <Variable name>='NO'.

For cycles, it is possible to assign more than one distribution to the attribute 'Value' so that the value is changed after every cycle. Separate the distribution with a ';'. During simulation the first distribution will be run in the first cycle, the second distribution in the second cycle etc.

Geben Sie die gewünschte Art der Verteilung mit den zugehörigen Parametern an.

Die Syntax für die Eingabe der stetigen Verteilungsfunktion ist:

- bei Normalverteilung: Normal(<Zahl1> ; <Zahl2>), wobei <Zahl1> der Erwartungswert und <Zahl2> die Standardabweichung ist.

Beispiel: Normal(1200; 100) - die Variable wird normalverteilt mit dem Erwartungswert 1200 und der Standardabweichung 100.

- bei Exponentialverteilung: Exponential(<Zahl>), wobei <Zahl> 1 geteilt durch den Erwartungswert (1/E) ist.

Beispiel: Exponential(0,002) - die Variable wird exponentialverteilt mit dem Erwartungswert 500.

- bei Gleichverteilung: Gleich(<Zahl1> ; <Zahl2>), wobei <Zahl1> die untere Grenze und <Zahl2> die obere Grenze ist.

Beispiel: Gleich(0 ; 100) - die Variable wird gleichverteilt zwischen den Grenzen 0 und 100.

Die Syntax für eine diskrete Verteilung ist:

Diskret(<Symbol1> <Zahl1>; <Symbol2> <Zahl2> ; ...)

Sie können zwei oder mehr Symbole mit ihren Eintrittswahrscheinlichkeiten (Zahl1, Zahl2, ...) definieren. Die Summe der Wahrscheinlichkeiten muß aber immer 1 ergeben!

Beispiel: Diskret(JA 0.6; NEIN 0.4) - die Variable wird mit einer Wahrscheinlichkeit von 0,6 mit dem Wert 'JA' und mit einer Wahrscheinlichkeit von 0,4 mit dem Wert 'NEIN' belegt. Daraus ergeben sich die zwei Übergangsbedingungen <Variablenname>='JA' und <Variablenname>='NEIN'.

Für Schleifendurchläufe können Sie im Attribut 'Wert' mehrere Verteilungen angeben, um die Variablenbelegung nach einem Schleifendurchlauf zu ändern. Trennen Sie die Verteilungen durch ';'. Bei der Simulation wird beim ersten Schleifendurchlauf die erste Verteilung angewandt, beim zweiten Durchlauf die zweite Verteilung usw.

- **Name (chapter "Description"):**

- **Description (chapter "Description"):**

Describe the characteristics of the random generator.

The description will be used for documentation purposes.

Geben Sie eine charakterisierende Beschreibung der Variablenbelegung ein.
Dient der Dokumentation.

- **Comment (chapter "Description"):**

Enter any comments about the random generator.
The comments will be used for documentation purposes.

Geben Sie einen Kommentar zur Variablenbelegung an.
Dient der Dokumentation.

- **Information on data collection (chapter "Description"):**

The "Information on data collection" enables the integration of existing information (documents, tables, graphs, web pages etc.)

Enter a path and file name in the field "Program arguments". If you want to open the referenced document with the program different then system default, select the program in the field "Executable".

Die "Erhebungsinformation" ermöglicht die Einbindung bereits bestehender Informationsquellen (Dokumente, Tabellen, Grafiken, Intranet-Seiten ...) in die Geschäftsprozeßmodelle.

Geben Sie im Feld "Parameter" Pfad und Dateiname ein. Falls Sie das referenzierte Dokument mit einem anderen als vom Betriebssystem vorgesehenen Programm öffnen möchten, so wählen Sie dieses im Feld "Auszuführendes Programm" aus.

- **Manual random generator (chapter "Description"):**

The activation of the manual random generator (Value 'Yes') enables the manual allocation of variables during the simulation.

The activation of the manual random generator is visualized by the system with a hand symbol in the graphical representation (on the left above the random generator object).

Die Aktivierung der manuellen Variablenbelegung (Wert 'Ja') ermöglicht die manuelle Zuweisung von Variablen während der Simulation.

Dies wird in der grafischen Modelldarstellung durch das Symbol einer Hand (links oberhalb des Variablenbelegungsobjekts) angezeigt.

- **Info zum Wert der Variablenbelegung (chapter "Deutsch"):**

Geben Sie den Wert der Variablenbelegung ein.
Dient der Dokumentation.

Enter the value of random generator.
For documentation purposes.

- **Beschreibung (chapter "Deutsch"):**

Geben Sie eine charakterisierende Beschreibung der Variablenbelegung ein.

Dient der Dokumentation.

Describe the characteristics of the object.

The description will be used for documentation purposes.

- **Kommentar (chapter "Deutsch"):**

Geben Sie einen Kommentar zur Variablenbelegung an.

Dient der Dokumentation.

Enter any comments about the object.

The comments will be used for documentation purposes.

2.14 Class "Resource" (ADONIS BPMS BP Library 3.9)



Resources are taken into consideration in the simulation algorithms "Workload analysis" and "Capacity analysis". The object "resource" in a business process model represents exactly one object "resource" from a working environment model.

The relation is executed by an AQL-expression, which is evaluated dynamically during the simulation.

In the "Capacity analysis" the resource object is set at its first usage with the corresponding resource from the working environment and that resource remains in use until the process is finished.

Ressourcen werden in der Simulation (bei Belastungs- und Auslastungsanalysen) berücksichtigt. Ein Objekt "Ressource" eines Geschäftsprozeßmodells repräsentiert genau ein Objekt "Ressource" aus einem Arbeitsumgebungsmodell.

Die Zuordnung erfolgt über einen AQL-Ausdruck, der während der Auswertung dynamisch verarbeitet wird.

Beim Prozeßdurchlauf wird ein Ressourcenobjekt bei der ersten Benutzung mit seinem Pendant aus der Arbeitsumgebung belegt und bis zum Ende des Prozeßdurchlaufs verbunden.

The following attributes are defined for the class "Resource":

- **Name (chapter "Description"):**

- **Order (chapter "Description"):**

This attribute can be set with the help of the 'Object numbering' function, which numbers the objects of the business process model.

This can be useful for example within the component 'Documentation', to ensure that all objects are documented in the required order.

Dieses Attribut kann mit Hilfe der Numerierungsfunktion, bei der die Objekte des Geschäftsprozeßmodells numeriert werden, belegt werden.

Die Reihenfolge wird beispielsweise bei Verwendung der Zusatzkomponente "Dokumentationskomponente" herangezogen, um die Objekte in gewünschter Abfolge zu dokumentieren.

- **Description (chapter "Description"):**

Describe the characteristics of the resource.

The description will be used for documentation purposes.

Geben Sie eine charakterisierende Beschreibung der Ressource ein.
Dient der Dokumentation.

- **Comment (chapter "Description"):**

Enter any comments about the resource.

The comments will be used for documentation purposes.

Geben Sie einen Kommentar zur Ressource an.
Dient der Dokumentation.

- **Type of resource (chapter "Description"):**

Select the type of the resource. The graphical representation on the drawing area will be adjusted accordingly.

Wählen Sie den Typ der Ressource aus. Es erfolgt eine entsprechende Darstellung auf der Zeichenfläche.

- **Screenshot (chapter "Description"):**

Select an image file which will be visualized as a resource symbol on the drawing area.

Wählen Sie eine Grafikdatei aus, die als Ressourcensymbol auf der Zeichenfläche visualisiert wird.

- **Selection (chapter "Description"):**

The value of this attribute is used in the simulation algorithms 'Capacity Analysis' and 'Workload Analysis'. It is possible to assign resources, i.e. to link activities with the resources that are required to execute them.

The effect of resources on the cycle time and waiting time of a business process can be examined by investigating the activities which use resources.

Clicking on the dialogue button above the selection box will give support for assigning resources.

In addition to the static elements of AQL, it is possible to use the dynamic construct 'current Performer' for resource assignment.

(Syntax: current Performer -> <Ressource relation>

It guarantees that the particular performer will use assigned resources during the execution of the activities.

 Der Wert dieses Attributs wird für die Simulation benötigt (Be- und Auslastungsanalyse). Sie können Aktivitäten mit den für Ihre Erledigung benötigten Ressourcen verknüpfen ("Ressourcenzuordnung").

So können beispielsweise die Auswirkungen von Ressourcen auf die Durchlauf- und Wartezeiten von Geschäftsprozessen und deren Aktivitäten ermittelt werden.

Rechts über dem Feld "Auswahl" befindet sich ein Button für die Eingabehilfe zur Ressourcenzuordnung. Neben den statischen Elementen von AQL kann zur Ressourcenzuordnung insbesondere das dynamische Konstrukt "aktueller Bearbeiter" eingesetzt werden (Syntax: aktueller Bearbeiter -> <Ressourcenrelation>).

So wird sichergestellt, daß derjenige Bearbeiter, der die aktuelle Aktivität ausführt, die zugeordnete Ressource verwendet.

- **Bezeichnung (chapter "Deutsch"):**

Geben Sie eine Bezeichnung der Ressource ein. Dient der Dokumentation.

- **Beschreibung (chapter "Deutsch"):**

Geben Sie eine charakterisierende Beschreibung der Ressource ein.

Dient der Dokumentation.

 Describe the characteristics of the object.

The description will be used for documentation purposes.

- **Kommentar (chapter "Deutsch"):**

Geben Sie einen Kommentar zur Ressource an.

Dient der Dokumentation.

 Enter any comments about the object.

The comments will be used for documentation purposes.

2.15 Class "Process"



A 'Process' is a reference on a Company map or a business process model.

Depending on the model referenced, a process or a business process can be symbolized in the object.

Ein "Prozeß" ist ein Verweis auf eine Prozeßlandkarte oder ein Geschäftsprozeßmodell.

In Abhängigkeit vom referenzierten Modell wird im Objekt entweder ein Prozeß oder ein Geschäftsprozeß symbolisiert.

The following attributes are defined for the class "Process":

- **Name (chapter "Description"):**

- **Referenced process (chapter "Description"):**

It is possible to reference a business process model or a process map which show the actual process in a detailed form.

The reference can be selected or changed by clicking on the add-icon (symbol 'plus').

If the option 'show name and reference' is disabled (default setting), the name of the referenced process will be displayed as a hyperlink beneath the object instead of the object name.

If the option is enabled, the name of the referenced process will be displayed as a hyperlink beneath the object name in a smaller font size.

Referenzieren Sie ein Geschäftsprozeßmodell oder eine Prozeßlandkarte, in welchem bzw. welcher der aktuelle Prozeß in detaillierter Form dargestellt ist.

Die Referenz wird über das Hinzufügen-Icon ('Plus'-Symbol) ausgewählt bzw. geändert.

Bei deaktivierter Option "Name und Referenz anzeigen" (Standardeinstellung) wird der Name des referenzierten Prozesses als Hyperlink unterhalb des Objekts statt dem Objektnamen angezeigt.

Bei aktivierter Option "Name und Referenz anzeigen" wird der Name des referenzierten Prozesses als Hyperlink unterhalb des Objektnamens in kleinerer Schrift angezeigt.

- **Display name and reference (chapter "Description"):**

If this option is activated, both the object name and the model name of the subprocess are displayed in the model graphic.

Aktivieren Sie diese Option, um sowohl den Objektnamen als auch den Modellnamen des referenzierten Prozesses in der Modellgrafik sehen zu können.

- **Order (chapter "Description"):**

This attribute can be set by using the numbering function, which numbers objects of a process map.

For example, the order will be used when generating a documentation to document the objects in a specific sequence.

Dieses Attribut kann mit Hilfe der Numerierungsfunktion, bei der die Objekte der Prozeßlandkarte numeriert werden, belegt werden.

Die Reihenfolge wird beispielsweise beim Generieren der Dokumentation herangezogen, um die Objekte in einer bestimmten Abfolge zu dokumentieren.

- **Description (chapter "Description"):**

Describe the characteristics of the process.

The description will be used for documentation purposes.

Geben Sie eine charakterisierende Beschreibung des Prozesses ein.

Dient der Dokumentation.

- **Comment (chapter "Description"):**

Enter any comments about the process.

The comments will be used for documentation purposes.

Geben Sie einen Kommentar zum Prozeß ein.

Dient der Dokumentation.

- **External process (chapter "Description"):**

Activate this option to define a process as external. External processes are executed outside the organisation or company under consideration.

Aktivieren Sie diese Option, um einen Prozess als extern zu definieren. Externe Prozesse werden außerhalb der betrachteten Organisation bzw. des betrachteten Unternehmens durchgeführt.

- **Referenced IT system elements (chapter "Description"):**

It is possible to reference one or more applications, infrastructure elements or services in an IT system model.

If you check the option "Visualize referenced IT system elements", the assigned IT system elements will be visualized on the drawing area. by clicking on the visualized IT system elements, you can navigate from the event to the assigned IT system elements.

Referenzieren Sie hier ein oder mehrere Anwendungen, Infrastrukturelemente oder Services aus einem IT-Systemmodell.

Wenn Sie die Option "Referenzierte IT systemelemente visualisieren" anklicken, werden die IT systemelemente auch auf der Zeichenfläche angezeigt. Gleichzeitig entsteht dort ein "Hotspot", d.h. man kann mit einem Mausklick vom Prozeß zu den zugewiesenen IT systemelementen im entsprechenden IT systemmodell wechseln.

- **Visualise referenced IT system elements (chapter "Description"):**

- **Open questions (chapter "Description"):**

Here you can enter any open questions which are still to be answered for this object.

If you enter any open questions, a red question mark appears above the object symbol on the drawing area.

Hinterlegen Sie hier eventuell noch vorhandene offene Fragen zu diesem Objekt.

Bei offenen Fragen erscheint auf der Zeichenoberfläche neben dem Objekt ein rotes Fragezeichen.

- **Input (chapter "Input/Output"):**

It is possible to reference documents from a document model, which are used as input for the performance of the process.

The reference can be selected or changed by clicking on the add-icon (symbol 'plus').

Referenzieren Sie jene Dokumente aus einem Dokumentenmodell, welche Input für die Durchführung des Prozesses sind.

Die Referenz wird über das Hinzufügen-Icon ('Plus'-Symbol) ausgewählt bzw. geändert.

- **Output (chapter "Input/Output"):**

It is possible to reference documents from a document model, which are created as output when performing a process..

The reference can be selected or changed by clicking on the add-icon (symbol 'plus').

Referenzieren Sie jene Dokumente aus einem Dokumentenmodell, welche als Output bei Durchführung des Prozesses entstehen.

Die Referenz wird über das Hinzufügen-Icon ('Plus'-Symbol) ausgewählt bzw. geändert.

- **Aggregated cycle time (chapter "Simulation results"):**

This attribute contains the aggregated cycle time of a business process model, which has been produced through simulation, with respect to one year or one business process. (More information about the relevant period can be found in the attribute 'Info on results' of the process start object.)

If a model of type 'Company map' or no model is referenced, the default value '00:000:00:00:00' is displayed.

Note: The attribute value is automatically updated and cannot be changed.

Dieses Attribut wird mit der durch Simulation ermittelten Durchlaufzeit belegt. Der Wert stammt aus dem referenzierten Geschäftsprozeßmodell (siehe "referenzierter Prozeß") und bezieht sich auf einen dort definierten Zeitraum - ein Jahr oder ein einzelner Geschäftsprozeß (Details dazu im Attribut "Ergebnisinfo" des Prozeßstarts).

Sollte entweder ein Modell vom Typ "Prozeßlandkarte" oder gar kein Modell referenziert sein, wird der Standardwert "00:000:00:00:00" angezeigt.

Hinweis: Der Attributwert wird automatisch aktualisiert und kann nicht manuell verändert werden.

- **Aggregated execution time (chapter "Simulation results"):**

This attribute contains the aggregated execution time of an activity with respect to one year or one business process. (More information about the relevant period can be found in the attribute 'Info on results').

If a model of type 'Company map' or no model is referenced, the default value '00:000:00:00:00' is displayed.

Note: The attribute value is automatically updated and cannot be changed.

Dieses Attribut wird mit einer durch Simulation ermittelten Bearbeitungszeit belegt. Der Wert stammt aus dem referenzierten Geschäftsprozeßmodell (siehe "referenzierter Prozeß") und bezieht sich auf einen dort definierten Zeitraum - ein Jahr oder ein einzelner Geschäftsprozeß (Details dazu im Attribut "Ergebnisinfo" des Prozeßstarts).

Sollte entweder ein Modell vom Typ "Prozeßlandkarte" oder gar kein Modell referenziert sein, wird der Standardwert "00:000:00:00:00" angezeigt.

Hinweis: Der Attributwert wird automatisch aktualisiert und kann nicht manuell verändert werden.

- **Aggregated waiting time (chapter "Simulation results"):**

This attribute contains the aggregated waiting time of an activity with respect to one year or one business process. (More information about the relevant period can be found in the attribute 'Info on results'.)

If a model of type 'Company map' or no model is referenced, the default value '00:000:00:00:00' is displayed.

Note: The attribute value is automatically updated and cannot be changed.

Dieses Attribut wird mit einer durch Simulation ermittelten Wartezeit belegt. Der Wert stammt aus dem referenzierten Geschäftsprozeßmodell (siehe "referenzierter Prozeß") und bezieht sich auf einen dort definierten Zeitraum - ein Jahr oder ein einzelner Geschäftsprozeß (Details dazu im Attribut "Ergebnisinfo" des Prozeßstarts).

Sollte entweder ein Modell vom Typ "Prozeßlandkarte" oder gar kein Modell referenziert sein, wird der Standardwert "00:000:00:00:00" angezeigt.

Hinweis: Der Attributwert wird automatisch aktualisiert und kann nicht manuell verändert werden.

- **Aggregated resting time (chapter "Simulation results"):**

This attribute contains the aggregated resting time of an activity with respect to one year or one business process. (More information about the relevant period can be found in the attribute 'Info on results'.)

If a model of type 'Company map' or no model is referenced, the default value '00:000:00:00:00' is displayed.

Note: The attribute value is automatically updated and cannot be changed.

Dieses Attribut wird mit einer durch Simulation ermittelten Liegezeit belegt. Der Wert stammt aus dem referenzierten Geschäftsprozeßmodell (siehe "referenzierter Prozeß") und bezieht sich auf einen dort definierten Zeitraum - ein Jahr oder ein einzelner Geschäftsprozeß (Details dazu im Attribut "Ergebnisinfo" des Prozeßstarts).

Sollte entweder ein Modell vom Typ "Prozeßlandkarte" oder gar kein Modell referenziert sein, wird der Standardwert "00:000:00:00:00" angezeigt.

Hinweis: Der Attributwert wird automatisch aktualisiert und kann nicht manuell verändert werden.

- **Aggregated transport time (chapter "Simulation results"):**

This attribute contains the aggregated transport time of an activity with respect to one year or one business process. (More information about the relevant period can be found in the attribute 'Info on results'.)

If a model of type 'Company map' or no model is referenced, the default value '00:000:00:00:00' is displayed.

Note: The attribute value is automatically updated and cannot be changed.

Dieses Attribut wird mit einer durch Simulation ermittelten Transportzeit belegt. Der Wert stammt aus dem referenzierten Geschäftsprozeßmodell (siehe "referenzierter Prozeß") und bezieht sich auf einen dort definierten Zeitraum - ein Jahr oder ein einzelner Geschäftsprozeß (Details dazu im Attribut "Ergebnisinfo" des Prozeßstarts).

Sollte entweder ein Modell vom Typ "Prozeßlandkarte" oder gar kein Modell referenziert sein, wird der Standardwert "00:000:00:00:00" angezeigt.

Hinweis: Der Attributwert wird automatisch aktualisiert und kann nicht manuell verändert werden.

- **Aggregated costs (chapter "Simulation results"):**

This attribute contains the aggregated costs of an activity with respect to one year or one business process. (More information about the relevant period can be found in the attribute 'Info on results'.)

If a model of type 'Company map' or no model is referenced, the default value '00:000:00:00:00' is displayed.

Note: The attribute value is automatically updated and cannot be changed.

Dieses Attribut wird mit den durch Simulation ermittelten Kosten belegt. Der Wert stammt aus dem referenzierten Geschäftsprozeßmodell (siehe "referenzierter Prozeß") und bezieht sich auf einen dort definierten Zeitraum - ein Jahr oder ein einzelner Geschäftsprozeß (Details dazu im Attribut "Ergebnisinfo" des Prozeßstarts).

Sollte entweder ein Modell vom Typ "Prozeßlandkarte" oder gar kein Modell referenziert sein, wird der Standardwert "0,000000" angezeigt.

Hinweis: Der Attributwert wird automatisch aktualisiert und kann nicht manuell verändert werden.

- **Aggregated personnel costs (chapter "Simulation results"):**

This attribute contains the aggregated personnel costs of an activity with respect to one year or one business process. (More information about the relevant period can be found in the attribute 'Info on results'.)

If a model of type 'Company map' or no model is referenced, the default value '00:000:00:00:00' is displayed.

Note: The attribute value is automatically updated and cannot be changed.

Dieses Attribut wird mit den durch Simulation ermittelten Personalkosten belegt. Der Wert stammt aus dem referenzierten Geschäftsprozeßmodell (siehe "referenzierter Prozeß") und bezieht sich auf einen dort definierten Zeitraum - ein Jahr oder ein einzelner Geschäftsprozeß (Details dazu im Attribut "Ergebnisinfo" des Prozeßstarts).

Sollte entweder ein Modell vom Typ "Prozeßlandkarte" oder gar kein Modell referenziert sein, wird der Standardwert "0,000000" angezeigt.

Hinweis: Der Attributwert wird automatisch aktualisiert und kann nicht manuell verändert werden.

- **Color (chapter "Representation"):**

You can define the object color as follows:

- Select a color in the 'Color' window which can be opened by clicking on the dialog button (on the right above the attribute field).

- Enter a color name (e.g. 'cornflowerblue'; a list of the color names can be found in the user documentation or in the online help).

- Enter an hexadecimal value (e.g. '\$FFFFFF' for white), where the value begins with '\$' and contains the red, green and blue values with two digits for each.

Die Farbe des Objekts kann definiert werden durch:

- die Auswahl einer Farbe über das Fenster "Farben", welches Sie durch Anklicken des Dialog-Buttons (rechts oberhalb des Attributfelds) öffnen

- die Eingabe eines Farbnamens (z.B. "cornflowerblue"; eine Liste finden Sie in Benutzerdokumentation und Online-Hilfe)

- die Eingabe eines Hexadezimalwerts (z.B. "\$FFFFFF" für white/weiß), wobei der Wert mit '\$' beginnt und daran anschließend - jeweils zweistellig - die Rot-, Grün-, und Blauwerte beinhaltet

- **Font size (chapter "Representation"):**

Wählen Sie den Schriftgrad (Schriftgröße) für die Darstellung des angezeigten Texts aus.

- **Bezeichnung (chapter "Deutsch"):**

Geben Sie eine Bezeichnung des Prozesses ein. Dient der Dokumentation.

- **Beschreibung (chapter "Deutsch"):**

Geben Sie eine charakterisierende Beschreibung des Prozesses ein.

Dient der Dokumentation.

Describe the characteristics of the object.

The description will be used for documentation purposes.

- **Kommentar (chapter "Deutsch"):**

Geben Sie einen Kommentar zum Prozeß ein.

Dient der Dokumentation.

Enter any comments about the object.

The comments will be used for documentation purposes.

2.16 Class "Performance indicator overview"



The class 'Performance indicator overview' provides an overview of all performance indicators defined in a business process or a company map.

In each business process model or a company map with performance indicators, exactly one object of type 'Performance indicator overview' has to be defined in order to perform initialisation and calculation of current values.

Die Klasse 'Kennzahlenübersicht' gibt einen Überblick über alle Kennzahlen, die für einen Geschäftsprozeß bzw. eine Prozeßlandkarte definiert wurden.

In jedem Geschäftsprozeßmodell bzw. in jeder Prozeßlandkarte, in der Kennzahlen definiert werden, muß für die Initialisierung und die Aktualisierung der IST-Werte genau ein Objekt der Klasse 'Kennzahlenübersicht' definiert werden.

The following attributes are defined for the class "Performance indicator overview":

- **Name (chapter "Description"):**

- **Description (chapter "Description"):**

Describe the characteristics of the performance indicator overview.

The description will be used for documentation purposes.

Geben Sie eine charakterisierende Beschreibung der Kennzahlenübersicht an.

Dient der Dokumentation.

- **Comment (chapter "Description"):**

Enter any comments about the performance indicator overview.

The comments will be used for documentation purposes.

Geben Sie einen Kommentar zur Kennzahlenübersicht an.

Dient der Dokumentation.

- **Performance indicator overview (chapter "Performance indicators"):**

In each business process model or a company map with performance indicators, exactly one object of type 'Performance indicator overview' has to be defined in order to perform initialisation and calculation of current values.

Otherwise an error message is displayed during initialisation or calculation.

References can be added to performance indicators using the add button. After the calculation the detailed information about each performance indicator (target value, current value, status, score and updated) will be displayed on the drawing area.

In jedem Geschäftsprozeßmodell bzw. in jeder Prozeßlandkarte, in der Kennzahlen definiert werden sollen, muß für die Initialisierung und die Aktualisierung der IST-Werte genau ein Objekt der Klasse 'Kennzahlenübersicht' definiert werden.

Andernfalls werden entsprechende Hinweise bei der Initialisierung bzw. Aktualisierung ausgegeben.

Fügen Sie über den Hinzufügen-Button Referenzen auf Kennzahlen hinzu. Nach der Aktualisierung werden Detailinformationen zu den Kennzahlen (SOLL-Wert, IST-Wert, Aktueller Zustand, Score und updated) auf der Zeichenfläche visualisiert.

- **Database access (chapter "Database parameter"):**

The database access contains all relevant parameter to establish a connection to an external database, which contains the as-is values of the indicators.

Der Datenbankzugriff enthält alle relevanten Parameter, um eine Verbindung zu einer externen Datenbank aufzubauen, in der die IST-Werte der Kennzahlen zur Verfügung stehen.

- **Planning period (chapter "Period configuration"):**

Specify the planning period for the initialization and actualization of the target values records.

The description of the planning period (starting point, duration) is defined as a reusable profile and can be selected or changed by clicking on the add-icon (symbol 'plus').

NOTE:

If no planning period is defined, a warning message is displayed during the initialization resp. actualization.

HINT:

If none of the available profiles corresponding to your requirements, please refer to your ADONIS-Administrator to create a new profile.

Geben Sie die Planungsperiode für die Initialisierung und Aktualisierung der Zielwertetabellen an.

Die Beschreibung der Planungsperiode (d.h. Beginn und Länge) ist als wiederverwendbares Profil definiert und wird über das Hinzufügen-Icon ('Plus'-Symbol) ausgewählt bzw. geändert.

Die hinterlegte Planungsperiode hat Gültigkeit für alle Kennzahlen, die in einem Geschäftsprozeßmodell bzw. einer Prozeßlandkarte definiert werden.

HINWEIS:

Wenn keine Planungsperiode definiert ist, wird ein entsprechender Hinweis im Zuge der Initialisierung bzw. Aktualisierung ausgegeben.

HINWEIS:

Sollte keines der verfügbaren Profile Ihren Bedürfnissen entsprechen, wenden Sie sich an Ihren ADONIS-Administrator, um ein neues Profil erstellen zu lassen.

- **Bezeichnung (chapter "Deutsch"):**

Geben Sie die Bezeichnung ein. Dient der Dokumentation.

- **Beschreibung (chapter "Deutsch"):**

Geben Sie eine charakterisierende Beschreibung der Kennzahlenübersicht an.
Dient der Dokumentation.

Describe the characteristics of the object.
The description will be used for documentation purposes.

- **Kommentar (chapter "Deutsch"):**

Geben Sie einen Kommentar zur Kennzahlenübersicht an.
Dient der Dokumentation.

Enter any comments about the object.
The comments will be used for documentation purposes.

2.17 Class "Performance indicator"



Use the class "Performance indicator" to define performance indicators in business process models and company maps.

Performance indicators can be assigned to activity and process objects using the "Owns" relation.

Mit der Klasse "Kennzahl" können Prozeßkennzahlen in Geschäftsprozeßmodellen und Prozeßlandkarten definiert werden.

Kennzahlen können Aktivitäten und Prozeßstart-Objekten über die Beziehung "besitzt" zugeordnet werden.

The following attributes are defined for the class "Performance indicator":

- **Name (chapter "Description"):**

- **Order (chapter "Description"):**

This attribute can be set with the help of the 'Object numbering' function, which numbers the objects of the business process model.

This can be useful for example within the component 'Documentation', to ensure that all objects are documented in the required order.

Dieses Attribut kann mit Hilfe der Numerierungsfunktion, bei der die Objekte des Geschäftsprozeßmodells numeriert werden, belegt werden.

Die Reihenfolge wird beispielsweise bei Verwendung der Zusatzkomponente "Dokumentationskomponente" herangezogen, um die Objekte in gewünschter Abfolge zu dokumentieren.

- **Description (chapter "Description"):**

Describe the characteristics of the object.

The description will be used for documentation purposes.

Geben Sie eine charakterisierende Beschreibung der Kennzahl an.

Dient der Dokumentation.

- **Comment (chapter "Description"):**

Enter any comments about the performance indicator.

The comments will be used for documentation purposes.

Geben Sie einen Kommentar zur Kennzahl an.

Dient der Dokumentation.

- **Periodicity (chapter "Details"):**

Define the periodicity of the performance indicator.

Please note that the target values have to be entered with the corresponding period!

Legen Sie hier fest, auf welchen Zeitraum sich diese Kennzahl bezieht. Es können Jahres-, Halbjahres-, Quartals-, Monats-, Wochen- und Tageskennzahlen definiert werden.

Beachten Sie, daß die SOLL-Werte immer je Betrachtungsperiode angegeben werden müssen!

- **Change of referenced date (year) (chapter "Details"):**

By using this attribute you can determine which year is used to calculate the current values.

An entry of 0 results in a calculation corresponding to the current year. If you choose -1 the calculation corresponds to the previous year.

Über dieses Attribut können Sie bestimmen, auf welches Jahr sich die Berechnung dieser Kennzahl bei der Aktualisierung bezieht.

Das Jahr wird relativ zum aktuellen Datum angegeben. Eine Angabe von 0 bewirkt, daß sich die Berechnung auf das aktuelle Datum bezieht. Die Angabe von z.B. -1 bewirkt, daß sich die Berechnung auf das vergangene Jahr bezieht.

Wollen Sie z.B. immer eine Kennzahl aus dem Vorjahr beziehen, geben Sie bei der "Änderung des Bezugszeitraumes (Jahr)" den Wert "-1" ein.

- **Change of referenced date (month) (chapter "Details"):**

By using this attribute you can determine which month is used to calculate the current values.

An entry of 0 results in a calculation corresponding to the current month. If you choose -1 the calculation corresponds to the previous month.

Über dieses Attribut können Sie bestimmen, auf welches Monat sich die Berechnung dieser Kennzahl bei der Aktualisierung bezieht.

Das Monat wird relativ zum aktuellen Datum angegeben. Eine Angabe von 0 bewirkt, daß sich die Berechnung auf das aktuelle Monat bezieht. Die Angabe von z.B. -1 bewirkt, daß sich die Berechnung auf das letzte Monat bezieht.

Wollen Sie z.B. immer eine Kennzahl aus dem Vormonat beziehen, geben Sie bei der "Änderung des Bezugszeitraumes (Monat)" den Wert "-1" ein.

- **Indicator type (chapter "Details"):**

Determines whether the indicator is an absolute or relative indicator.

Absolute indicators are measured in a specific unit of measurement (e.g. revenue).

Relative indicators represent a ratio e.g. ROE (return on equity).

In cases of an absolute indicator, the current value is compared with the cumulated target values in the given time period.

In cases of a relative indicator, the current value is compared with the target value in the given time period, i.e. the target values are NOT cumulated.

Geben Sie an, ob es sich bei dieser Kennzahl um eine relative bzw. absolute Kennzahl handelt.

Absolute Kennzahlen geben in der Regel einen konkreten Wert (in einer Einheit gemessen) an. Durchlaufzeiten stellen beispielsweise absolute Kennzahlen dar.

Relative Kennzahlen stellen ein Verhältnis dar und sind meist dimensionslos (oder sind ein Prozentwert). Ein Beispiel für eine relative Kennzahl stellt der Anteil abgewiesener Überweisungsanträge dar.

Für absolute Kennzahlen wird der aktuelle IST-Wert der Kennzahl der zu aktualisierenden Periode mit den kumulierten Soll-Werten der Kennzahl verglichen. D.h. für Quartalskennzahlen sind dies die SOLL-Werte der Betrachtungsperioden des Quartals, für Halbjahreskennzahlen jene des halben Jahres usw.

Für relative Kennzahlen wird der aktuelle Wert der Kennzahl mit dem SOLL-Wert der zu aktualisierenden Periode verglichen. In diesem Fall werden die SOLL-Werte NICHT kumuliert.

- **Unit (chapter "Details"):**

Enter the unit of measurement.

Geben Sie hier die Maßeinheit der Kennzahl ein.

- **Limit type (chapter "Details"):**

It is possible to influence the calculation status with the attribute 'limit type'. The following options are available:

- Less is better: Current values higher than the target value are not desired (e.g. costs)
- More is better: Current values lower than the target value are not desired (e.g. revenue). The threshold limits will be subtracted from the target values.
- Two-sided: The threshold types have an effect in both directions around the target value.

Mit der Begrenzungsart können Sie die Statusberechnung der Kennzahlen beeinflussen. Folgende Modi können gewählt werden:

- von oben: Abweichungen nach oben vom Soll-Wert sind nicht erwünscht. (Bsp. Durchlaufzeiten) Hier werden die Toleranzgrenzen zu den Sollwerten hinzuaddiert.
- von unten: Abweichungen nach unten vom Soll-Wert sind nicht erwünscht. (Bsp. Umsatz) Hier werden die Toleranzgrenzen von den Sollwerten subtrahiert.
- beidseitig: Die Toleranzgrenzen wirken in beide Richtungen rund um den Soll-Wert. Hiermit kann eine bestimmte Bandbreite an Schwankungen erlaubt werden.

- **Threshold green/yellow (chapter "Details"):**

Enter the value from which the status of the performance indicator should be displayed with a yellow traffic-light.

Example: Target value = 150
 Threshold green/yellow = 10
 Threshold yellow/red = 20
 Limit type = More is better

The following traffic-light colors will be displayed:

- green: if current value > 140
- yellow: if current value <= 140 and > 130
- red: if current value <= 130

Enter an absolute target value.

Geben Sie hier die Toleranzgrenze für den SOLL-Wert an, ab dem der Status der Kennzahl mit grün visualisiert werden soll:

Beispiele: SOLL-Wert = 150
 Toleranzgrenze grün/gelb = 10

Part III

Toleranzgrenze gelb/rot = 20

Begrenzungsart = von unten

Folgende Bereiche ergeben sich für die Visualisierung des Status der Kennzahl:

- grün: ab einem IST-Wert von > 140
- gelb: ab einem IST-Wert von ≤ 140 bis > 130
- rot: ab einem IST-Wert von ≤ 130

Ein Kennzahlenwert von 141 wird mit einer grünen Ampelfarbe visualisiert.

Geben Sie absolute Werte vom SOLL-Wert an.

- **Threshold yellow/red (chapter "Details"):**

Enter the value from which the status of the performance indicator should be displayed with a yellow traffic-light.

Example: Target value = 150

Threshold green/yellow = 10

Threshold yellow/red = 20

Limit type = More is better

The following traffic-light colors will be displayed:

- green: if current value > 140
- yellow: if current value ≤ 140 and > 130
- red: if current value ≤ 130

Enter an absolute target value.

Geben Sie hier die Toleranzgrenze für den SOLL-Wert an, ab dem der Status der Kennzahl mit gelb visualisiert werden soll:

Beispiele: SOLL-Wert = 150

Toleranzgrenze grün/gelb = 10

Toleranzgrenze gelb/rot = 20

Begrenzungsart = von unten

Folgende Bereiche ergeben sich für die Visualisierung des Status der Kennzahl:

- grün: ab einem IST-Wert von > 140
- gelb: ab einem IST-Wert von ≤ 140 bis > 130
- rot: ab einem IST-Wert von ≤ 130

Ein Kennzahlenwert von 134 wird mit einer gelben Ampelfarbe visualisiert.

Geben Sie absolute Werte vom SOLL-Wert an.

- **Responsibility (chapter "Details"):**

It is possible to reference a role or a performer from a working environment model, which is responsible for the indicator.

The reference can be selected or changed by clicking on the add-icon (symbol 'plus').

Referenzieren Sie eine Rolle oder einen Bearbeiter aus einem Arbeitsumgebungsmodell, welche bzw. welcher für die Kennzahl verantwortlich ist.

Die Referenz wird über das Hinzufügen-Icon ('Plus'-Symbol) ausgewählt bzw. geändert.

- **Data source (chapter "Details"):**

This attributes determines the source of the data fetch.

If you choose 'Database', edit the attribute 'SQL-Statement' with an appropriate SQL-command. Additionally, a database access has to be defined for the business process model or the company map in the class 'Performance indicator overview'.

Make sure the entry 'Excel file' and the attributes in the chapter 'Excel file' are valid.

The attribute 'Manual data input' in the chapter of the same corresponds to the entry 'Manual data input'.

Geben Sie an, ob der Wert der Kennzahl aus operativen Daten einer relationalen

Datenbank aus den Daten einer Excel-Tabelle oder aus den Daten des Attributes "Manuelle Dateneingabe" berechnet wird.

Wird als Datenquelle 'Datenbank' angegeben, muß auf Ebene der Klasse 'Kennzahlenübersicht' der Datenbankzugriff pro Geschäftsprozeßmodell bzw. Prozeßlandkarte im Attribut 'Datenbankzugriff' definiert und das

Attribut 'SELECT-Statement' der Klasse 'Kennzahl' belegt werden.

Wird als Datenquelle 'Excel-Tabelle' angegeben, müssen die Attribute 'Tabelle', 'Name des Tabellenblatts' und 'Zelle' belegt werden.

Wird als Datenquelle 'Manuelle Dateneingabe' angegeben, wird der im Attribut 'Manuelle Dateneingabe' im Kapitel 'Manuelle Datenquelle' hinterlegte Wert für die Berechnung der Kennzahl herangezogen.

- **History (chapter "History"):**

This table is used to represent the results of the target/current comparisons.

The menu entry 'Current value initialisation' prepares the table. Afterwards the target values for each time period can be entered.

The menu entry 'Current value calculation' takes the current values in the corresponding rows of the table. Additional target level achievements and scores are calculated.

Current values are entered in the column 'Current value' and target values in the column 'Target value'.

The Status is calculated using the current value, target value, limit type and threshold values and is entered in the column 'Status'.

The Score is entered in the 'Score' column and the calculation date in the column 'Updated'.

Die Zielwerte-Tabelle dient dem SOLL-IST-Vergleich.

Die Tabelle wird mit dem Menüpunkt 'IST-Werte initialisieren' (in der Evaluationskomponente) vorbereitet. Danach können die SOLL-Werte für jede Betrachtungsperiode erfasst werden.

Mit dem Menüpunkt 'IST-Werte aktualisieren' wird der aktuelle IST-Werte aus dem operativen System gelesen und in die Zeilen der aktuellen Betrachtungsperiode eingetragen.

IST-Werte werden für die jeweiligen Betrachtungsperioden in der Spalte 'IST-Wert', die SOLL-Werte für die Perioden in der Spalte 'SOLL-Wert' eingetragen.

Der Aktuelle Zustand errechnet sich aus dem IST-Wert dem SOLL-Wert, der angegebenen Begrenzungsart und den Toleranzgrenzen und wird in die gleichnamige Spalte eingetragen.

Der Score der Kennzahl und das Datum der Aktualisierung wird in den Spalten 'Score' bzw. 'Updated' eingetragen. Kommentare können optional in der Spalte 'Kommentar' für jede Betrachtungsperiode hinterlegt werden.

- **SELECT-Statement (chapter "DB data source"):**

The value of the indicator is determined with this statement.

The SQL-statement must be entered only if a database is defined as the data source.

The interface to the operational database is entered for each business process model or a company map in the object 'Performance indicator overview' in the chapter 'Database parameter'.

Mit dieser Anweisung wird der Wert für die Kennzahl aus der operativen Datenbasis ermittelt.

Die SQL-Anweisung muß nur angegeben werden, wenn als Datenquelle 'Datenbank' angegeben wurde.

Die Schnittstelle zur Datenbank definieren Sie pro Geschäftsprozeßmodell bzw. pro Prozeßlandkarte in dem Objekt der Klasse 'Kennzahlenübersicht' im Kapitel 'DB-Parameter'.

- **Table (chapter "Excel data source"):**

Specify from which Excel-table the indicator should be read.

The reference to this Excel-table is defined as a reusable profile and can be selected or changed by clicking on the add-icon (symbol 'plus').

The relation to a sheet of the referenced Excel-table is specified by the attribute 'name of the Excel-sheet'.

The relation to a cell in the given sheet of the referenced Excel-table is specified by the attribute 'Cell'.

HINT:

The table has to be specified only if the value 'Excel-Tabelle' (Excel-table) has been selected from the attribute 'data source' in the chapter 'Details'.

HINT:

If none of the available profiles is corresponding to your requirements, please refer to your ADONIS-Administrator to create a new profile.

Geben Sie an, aus welcher Excel-Tabelle die Kennzahl gelesen werden soll.

Die Referenz auf diese Excel-Tabelle ist als wiederverwendbares Profil definiert und wird über das Hinzufügen-Icon ('Plus'-Symbol) ausgewählt bzw. geändert.

Der Bezug auf ein Blatt der referenzierten Excel-Tabelle erfolgt über das Attribut 'Name des Tabellenblatts'.

Der Bezug auf eine Zelle im angegebenen Blatt der referenzierten Excel-Tabelle erfolgt über das Attribut 'Zelle'.

HINWEIS:

Die Tabelle muß nur dann angegeben werden, wenn im Attribut 'Datenquelle' (Kapitel 'Details') der Wert 'Excel-Tabelle' gewählt wurde.

HINWEIS:

Sollte keines der verfügbaren Profile Ihren Bedürfnissen entsprechen, wenden Sie sich an Ihren ADONIS-Administrator, um ein neues Profil erstellen zu lassen.

- **Sheet (chapter "Excel data source"):**

Define the name of the Excel sheet of the referenced Excel file.

Bitte hinterlegen Sie hier den Namen des Tabellenblattes in der referenzierten Excel-Datei.

- **Cell (chapter "Excel data source"):**

The attribute 'cell' determines the value of the indicator. The format of the cell reference should be as follows: <Column>, <Row>.

Only numerical figures or expressions are allowed for columns and rows.

Example: the cell reference '4,(1+2*\$(MONTH_END))' indicates the fourth column of an Excel sheet. The indicated row is calculated by the current month * 2 + 1.

In this example, if the calculation takes place in Mai 2004, the result will be: column 4 and row 11 (5 * 2 + 1 = 11).

The cell reference corresponds to the attributes 'Sheet' and has to be defined only if 'Excel file' is chosen as data source.

Note: Excel functions can be used within cell references.

Die hier angegebene Zelle wird für die Ermittlung der Kennzahl verwendet. Der Zellenbezug hat das Format <Spalte>,<Zeile> wobei Spalte und Zeile numerische Werte bzw. Ausdrücke sein dürfen.

Beispielsweise entspricht der Zellenbezug '4,(1+2*\$(MONAT_ENDE))' dem Wert der vierten Spalte der Zeile: aktuelles_Monat * 2 + 1.

Bei einer Aktualisierung im Mai 2004 wird gemäß obenstehender Formel der Wert der Spalte 4 und der Zeile (5 * 2 + 1 = 11) herangezogen.

Die Zelle bezieht sich immer auf die im Attribut 'Tabelle' angegebene Excel-Tabelle und muß nur angegeben werden, wenn als Datenquelle 'Excel-Tabelle' angegeben wird.

Hinweis: Im Zellenbezug können auch Excel-Funktionen verwendet werden.

- **Manual data input (chapter "Manual data source"):**

Enter the value of the indicator. This value is used to calculate the current values of performance indicators for a specific time period in case of manual data input.

Geben Sie hier den Wert der Kennzahl ein, der bei manueller Datenanbindung für die jeweils aktualisierte Periode herangezogen werden soll.

- **Font size (chapter "Representation"):**

Choose the appropriate font size to display the description text.

Wählen Sie den Schriftgrad (Schriftgröße) für die Darstellung des angezeigten Texts aus.

- **Font style (chapter "Representation"):**

Choose the appropriate font style to display the description text.

Part III

Wählen Sie den Schriftstil für die Darstellung des Texts aus.

- **Display current value (chapter "Representation"):**

Choose whether the current value should be displayed or not.

Wählen Sie aus, ob der IST-Wert unterhalb der Kennzahl visualisiert werden soll.

- **Display score (chapter "Representation"):**

Choose whether the score should be displayed above the performance indicator.

Wählen Sie aus, ob der Score oberhalb der Kennzahl visualisiert werden soll.

- **Display periodicity (chapter "Representation"):**

Choose whether the periodicity should be displayed with the performance indicator.

Wählen Sie aus, ob der Bezugszeitraum neben der Kennzahl visualisiert werden soll.

- **Display status (chapter "Representation"):**

Choose whether the status should be displayed or not.

Wählen Sie aus, ob der Status neben der Kennzahl visualisiert werden soll.

- **Bezeichnung (chapter "Deutsch"):**

Geben sie eine Bezeichnung ein. Dient der Dokumentation.

- **Beschreibung (chapter "Deutsch"):**

Geben Sie eine charakterisierende Beschreibung der Kennzahl an.

Dient der Dokumentation.

Describe the characteristics of the object.

The description will be used for documentation purposes.

- **Kommentar (chapter "Deutsch"):**

Geben Sie einen Kommentar zur Kennzahl an.

Dient der Dokumentation.

Enter any comments about the object.

The comments will be used for documentation purposes.

2.18 Class "Document"



A 'Document' contains information and supports the execution of an activity.
The required documents are referenced to from the activities of a business process model.

Ein "Dokument" enthält Information und unterstützt die Verrichtung einer Tätigkeit (Aktivität).
Zur Verrichtung verwendete (benötigte) Dokumente werden aus den Aktivitäten eines Geschäftsprozessmodells referenziert.

The following attributes are defined for the class "Document":

- **Name (chapter "Description"):**

- **Referenced document (chapter "Description"):**

'Referenced documents' enable the integration of existing documents, as well as external documents.

"Referenziertes Dokument" ermöglicht sowohl die Einbindung von bereits bestehenden Dokumenten als auch von ergänzenden externen Dokumenten.

- **Display file extension (chapter "Description"):**

The option 'show file name' enables the visualization of the file name of the referenced document.

Die Option "Dateinamen anzeigen" ermöglicht die Visualisierung des Dateinamens des referenzierten Dokuments.

- **Description (chapter "Description"):**

Describe the characteristics of the document.

The description will be used for documentation purposes.

Geben Sie eine charakterisierende Beschreibung des Dokuments ein.

Dient der Dokumentation.

- **Comment (chapter "Description"):**

Enter any comments about the object.

The comments will be used for documentation purposes.

Geben Sie einen Kommentar zum Dokument ein.

Dient der Dokumentation.

- **Responsible role (chapter "Description"):**

It is possible to reference a role from a working environment model, which is responsible for the document.

The reference can be selected or changed by clicking on the add-icon (symbol 'plus').

Referenzieren Sie jene Rolle aus einem Arbeitsumgebungsmodell, welche für das Dokument verantwortlich ist.

Die Referenz wird über das Hinzufügen-Icon ('Plus'-Symbol) ausgewählt bzw. geändert.

- **Referenced document model (chapter "Description"):**

It is possible to reference a document model, which shows the actual document in a detailed form.

The reference can be selected or changed by clicking the add-icon (symbol 'plus').

When a reference is entered, an arrow symbol is displayed in the left lower part of the object.

You can navigate into the referenced sub-model by clicking this symbol.

Referenzieren Sie ein Dokumentenmodell, in welchem das aktuelle Dokument in detaillierter Form dargestellt ist.

Die Referenz wird über das Hinzufügen-Icon ('Plus'-Symbol) ausgewählt bzw. geändert.

Bei eingetragener Referenz wird ein Pfeil-Symbol links unten im Objekt angezeigt.

Über dieses Pfeil-Symbol kann durch Anklicken in das referenzierte Submodell navigiert werden.

- **Bezeichnung (chapter "Deutsch"):**

Geben Sie eine Bezeichnung des Dokuments ein. Dient der Dokumentation.

- **Beschreibung (chapter "Deutsch"):**

Geben Sie eine charakterisierende Beschreibung des Dokuments ein.

Dient der Dokumentation.

Describe the characteristics of the object.

The description will be used for documentation purposes.

- **Kommentar (chapter "Deutsch"):**

Geben Sie einen Kommentar zum Dokument ein.

Dient der Dokumentation.

Enter any comments about the object.

The comments will be used for documentation purposes.

2.19 Class "Note" (ADONIS BPMS BP Library 3.9)



The 'Note' allows free text to be placed within a model.

Die "Notiz" erlaubt die Darstellung von beliebigen Texten innerhalb der graphischen Modellbeschreibung.

The following attributes are defined for the class "Note":

- **Text (chapter "Description"):**

Enter the text for the note.

Geben Sie hier den Text der Notiz ein.

- **Font size (chapter "Description"):**

Select the font size for the text that is displayed on the drawing area.

Wählen Sie den Schriftgrad (Schriftgröße) für die Darstellung des angezeigten Texts aus.

- **Font style (chapter "Description"):**

Select the font style for the text that is displayed on the drawing area.

Wählen Sie den Schriftstil für die Darstellung des Texts aus.

- **Color (chapter "Description"):**

You can define the object color as follows:

Part III

- Select a color in the 'Color' window which can be opened by clicking on the dialog button (on the right above the attribute field).
- Enter a color name (e.g. 'cornflowerblue'; a list of the color names can be found in the user documentation or in the online help).
- Enter an hexadecimal value (e.g. '\$FFFFFF' for white), where the value begins with '\$' and contains the the red, green and blue values with two digits for each.

Die Farbe des Objekts kann definiert werden durch:

- die Auswahl einer Farbe über das Fenster "Farben", welches Sie durch Anklicken des Dialog-Buttons (rechts oberhalb des Attributfelds) öffnen
- die Eingabe eines Farbnamens (z.B. "cornflowerblue"; eine Liste finden Sie in Benutzerdokumentation und Online-Hilfe)
- die Eingabe eines Hexadezimalwerts (z.B. "\$FFFFFF" für white/weiß), wobei der Wert mit '\$' beginnt und daran anschließend - jeweils zweistellig - die Rot-, Grün-, und Blauwerte beinhaltet

- **External graphic (chapter "Description"):**

Reference a graphic file.

The following file formats are available:

- "bmp"
- "gif"
- "ico"
- "jpeg"
- "png"
- "targa"
- "tiff"
- "wbmp"
- "xpm"

Enter a path and file name in the field "Program arguments". If you want to open the referenced file with the program different then system default, select the program in the field "Executable".

Referenzieren Sie eine Grafikdatei, die eingebunden werden soll.

Folgende Grafikformate werden unterstützt:

- "bmp"
- "gif"
- "ico"
- "jpeg"
- "png"
- "targa"
- "tiff"
- "wbmp"
- "xpm"

Falls diese Datei mit einem bestimmten Tool geöffnet werden soll, geben Sie dieses in der Auswahl an. Andernfalls "<automatisch>" wird die Standardeinstellung gewählt.

Im Feld "Parameter" geben Sie bitte Pfad und Dateinamen der Grafik an.

- **Calculate size of graphic automatically (chapter "Description"):**

This attribute calculates the exact area a referenced graphic needs.

It is recommended to activate the automatic calculation before referencing an external graphic.

If this function is activated, the size of the object "Note" is automatically adjusted to the objects' size. When changing the size the aspect ratio will be kept.

If it is deactivated, the graphic will be inserted minimized. The graphic must be adjusted manually without keeping the aspect ratio.

Diese Funktion ermöglicht die exakte Berechnung jener Fläche, die in die Notiz eingebundene Grafiken benötigen.

Es wird empfohlen, die automatische Berechnung der Grafikgröße vor dem Einbinden der externen Grafik zu aktivieren.

Ist sie aktiviert, so wird die Größe der Grafik der Größe des Objekts "Notiz" angepasst und das Verhältnis der Seitenlängen bleibt bei späterem Skalieren konstant.

Ist sie hingegen deaktiviert, so erscheint die Grafik in Minimalgröße auf der Zeichenfläche und muß händisch in die gewünschte Form gebracht werden. Dabei kann das Seitenverhältnis beliebig verändert werden.

- **Notiz (chapter "Deutsch"):**

Geben Sie die Notiz ein.

Enter the text of the annotation.

- **Notiz (chapter "Beschreibung (deutsch)"):**

Geben Sie die Notiz ein.

Enter the text of the annotation.

- **Text (chapter "Beschreibung"):**

Enter the text for the note.

Geben Sie hier den Text der Notiz ein.

- **Font size (chapter "Beschreibung"):**

Select the font size for the text that is displayed on the drawing area.

Wählen Sie den Schriftgrad (Schriftgröße) für die Darstellung des angezeigten Texts aus.

- **Font style (chapter "Beschreibung"):**

Select the font style for the text that is displayed on the drawing area.

Wählen Sie den Schriftstil für die Darstellung des Texts aus.

- **Color (chapter "Beschreibung"):**

You can define the object color as follows:

- Select a color in the 'Color' window which can be opened by clicking on the dialog button (on the right above the attribute field).
- Enter a color name (e.g. 'cornflowerblue'; a list of the color names can be found in the user documentation or in the online help).
- Enter an hexadecimal value (e.g. '\$FFFFFF' for white), where the value begins with '\$' and contains the the red, green and blue values with two digits for each.

Die Farbe des Objekts kann definiert werden durch:

- die Auswahl einer Farbe über das Fenster "Farben", welches Sie durch Anklicken des Dialog-Buttons (rechts oberhalb des Attributfelds) öffnen
- die Eingabe eines Farbnamens (z.B. "cornflowerblue"; eine Liste finden Sie in Benutzerdokumentation und Online-Hilfe)
- die Eingabe eines Hexadezimalwerts (z.B. "\$FFFFFF" für white/weiß), wobei der Wert mit '\$' beginnt und daran anschließend - jeweils zweistellig - die Rot-, Grün-, und Blauwerte beinhaltet

- **External graphic (chapter "Beschreibung"):**

Reference a graphic file.

The following file formats are available:

- "bmp"
- "gif"
- "ico"
- "jpeg"
- "png"
- "targa"
- "tiff"
- "wbmp"
- "xpm"

Enter a path and file name in the field "Program arguments". If you want to open the referenced file with the program different then system default, select the program in the field "Executable".

Referenzieren Sie eine Grafikdatei, die eingebunden werden soll.

Folgende Grafikformate werden unterstützt:

- "bmp"
- "gif"
- "ico"
- "jpeg"
- "png"
- "targa"

- "tiff"
- "wbmp"
- "xpm"

Falls diese Datei mit einem bestimmten Tool geöffnet werden soll, geben Sie dieses in der Auswahl an. Andernfalls "<automatisch>" wird die Standardeinstellung gewählt.

Im Feld "Parameter" geben Sie bitte Pfad und Dateinamen der Grafik an.

- **Calculate size of graphic automatically (chapter "Beschreibung"):**

This attribute calculates the exact area a referenced graphic needs.

It is recommended to activate the automatic calculation before referencing an external graphic.

If this function is activated, the size of the object "Note" is automatically adjusted to the objects' size. When changing the size the aspect ratio will be kept.

If it is deactivated, the graphic will be inserted minimized. The graphic must be adjusted manually without keeping the aspect ratio.

Diese Funktion ermöglicht die exakte Berechnung jener Fläche, die in die Notiz eingebundene Grafiken benötigen.

Es wird empfohlen, die automatische Berechnung der Grafikgröße vor dem Einbinden der externen Grafik zu aktivieren.

Ist sie aktiviert, so wird die Größe der Grafik der Größe des Objekts "Notiz" angepasst und das Verhältnis der Seitenlängen bleibt bei späterem Skalieren konstant.

Ist sie hingegen deaktiviert, so erscheint die Grafik in Minimalgröße auf der Zeichenfläche und muß händisch in die gewünschte Form gebracht werden. Dabei kann das Seitenverhältnis beliebig verändert werden.

2.20 Class "Aggregation" (ADONIS BPMS BP Library 3.9)



The aggregation supports the logical structure of model contents on the drawing area.

For an object that is placed in an Aggregation, there is an automatic creation of connections between the Aggregation and the objects in the model with the relation 'Is inside'.

The relation 'Is inside' is not visualized!

Die Aggregation unterstützt die logische Strukturierung von Modellinhalten auf der Zeichenfläche.

Von einem Objekt, das auf einer Aggregation plaziert wird, wird automatisch ein (unsichtbarer) Konnektor des Typs "ist innerhalb" zur Aggregation angelegt.

The following attributes are defined for the class "Aggregation":

- **Name (chapter "Description"):**

- **Display name (chapter "Description"):**

Select whether the object name should be displayed on the drawing area.

Wählen Sie, ob der Name der Aggregation auf der Zeichenfläche dargestellt werden soll.

- **Representation (chapter "Description"):**

Select whether the object name should be displayed inside or outside the object.

Wählen Sie aus, ob der Name außerhalb oder innerhalb des Objekts dargestellt werden soll.

- **Font size (chapter "Description"):**

Select the font size for the text that is displayed on the drawing area.

Wählen Sie den Schriftgrad (die Schriftgröße) für die Darstellung des angezeigten Texts aus.

- **Font style (chapter "Description"):**

Select the font style for the text that is displayed on the drawing area.

Wählen Sie den Schriftstil für die Darstellung des angezeigten Texts aus.

- **Description (chapter "Description"):**

Describe the characteristics of the aggregation.

The description will be used for documentation purposes.

Geben Sie eine charakterisierende Beschreibung der Aggregation an.

Dient der Dokumentation.

- **Comment (chapter "Description"):**

Enter any comments about the aggregation.

The comments will be used for documentation purposes.

Geben Sie einen Kommentar zur Aggregation an.

Dient der Dokumentation.

- **Graphical representation (chapter "Object display"):**

Different options are available for the graphical representation of this object, e.g. rectangle, arrow or circle.

Es stehen unterschiedliche Optionen zur grafischen Darstellung des Objekts zur Verfügung, bspw. Rechteck, Pfeil und Kreis.

- **Color (chapter "Object display"):**

You can define the object color as follows:

- Select a color in the 'Color' window which can be opened by clicking on the dialog button (on the right above the attribute field).
 - Enter a color name (e.g. 'cornflowerblue'; a list of the color names can be found in the user documentation or in the online help).
 - Enter an hexadecimal value (e.g. '\$FFFFFF' for white), where the value begins with '\$' and contains the red, green and blue values with two digits for each.
-

Die Farbe des Objekts kann definiert werden durch:

- die Auswahl einer Farbe über das Fenster "Farben", welches Sie durch Anklicken des Dialog-Buttons (rechts oberhalb des Attributfelds) öffnen
- die Eingabe eines Farbnamens (z.B. "cornflowerblue"; eine Liste finden Sie in Benutzerdokumentation und Online-Hilfe)
- die Eingabe eines Hexadezimalwerts (z.B. "\$FFFFFF" für white/weiß), wobei der Wert mit '\$' beginnt und daran anschließend - jeweils zweistellig - die Rot-, Grün-, und Blauwerte beinhaltet

- **Lines (chapter "Object display"):**

Select the type of representation for the framework.

Wählen Sie die Darstellungsart des Rahmens aus.

- **Bezeichnung (chapter "Deutsch"):**

Geben Sie eine Bezeichnung der Aggregation ein. Dient der Dokumentation.

- **Beschreibung (chapter "Deutsch"):**

Geben Sie eine charakterisierende Beschreibung der Aggregation an.

Dient der Dokumentation.

Describe the characteristics of the object.

The description will be used for documentation purposes.

- **Kommentar (chapter "Deutsch"):**

Geben Sie einen Kommentar zur Aggregation an.

Dient der Dokumentation.

Enter any comments about the object.

The comments will be used for documentation purposes.

2.21 Class "Swimlane (horizontal)" (ADONIS BPMS BP Library 3.9)

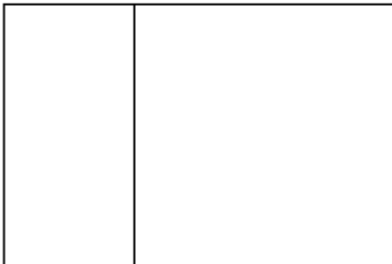

"Swimlanes" are areas of responsibilities (e.g. workgroups, units etc.) or represent IT System elements.

If a process is executed in multiple different areas of responsibilities, each area becomes a swimlane on its own. Each object of the process can be placed into its corresponding swimlane.

In each swimlane the responsible role, performer, or organizational unit from the working environment or an IT system element from the IT system model can be referenced.

"Schwimmbahnen" (engl. "swimlane") sind Verantwortlichkeitsbereiche (z.B. Arbeitsgruppen, Abteilungen etc.) oder repräsentieren IT systemelemente.

Läuft ein Prozeß in mehreren dieser Bereiche ab, so wird jeder Verantwortungsbereich in einer eigenen Schwimmbahn zusammengefasst und die entsprechenden Objekte des Geschäftsprozesses in dieser platziert.

In jeder Schwimmbahn kann die verantwortliche Rolle, der verantwortliche Mitarbeiter, die verantwortliche Organisationseinheit aus einem Arbeitsumgebungsmodell oder ein IT systemelement aus einem IT-Systemmodell referenziert werden.

The following attributes are defined for the class "Swimlane (horizontal)":

- **Name (chapter "Description"):**

- **Working environment (chapter "Description"):**

It is possible to reference an organizational element (role, performer or organizational unit) from a working environment model.

The reference can be selected or changed by clicking on the add-icon (symbol 'plus').

The name of the referenced organizational element will be displayed as a hyperlink on the left border of the lane instead of the object name.

Referenzieren Sie ein Organisationselement (d.h. Rolle, Bearbeiter oder Organisationseinheit) aus einem Arbeitsumgebungsmodell.

Die Referenz wird über das Hinzufügen-Icon ('Plus'-Symbol) ausgewählt bzw. geändert.

Der Name des referenzierten Organisationselements wird als Hyperlink am linken Rand der Schwimmbahn statt dem Objektnamen angezeigt.

- **Referenced IT system elements (chapter "Description"):**

It is possible to reference one application, infrastructure element or service in an IT System Model.

The reference can be selected or changed by clicking on the add-icon (symbol 'plus').

The name of the referenced IT System element will be displayed as a hyperlink on the left border of the lane instead of the object name unless some organizational elementattribute 'Working environment' is already referenced from this swimlane.

Referenzieren Sie hier eine Anwendung, ein Infrastrukturelement oder ein Service aus einem IT systemmodell.

Die Referenz wird über das Hinzufügen-Icon ('Plus'-Symbol) ausgewählt bzw. geändert.

Der Name des referenzierten IT systemelements wird als Hyperlink am linken Rand der Schwimmbahn statt dem Objektnamen angezeigt, sofern nicht bereits ein Organisationselement referenziert wird (Attribut 'Arbeitsumgebung').

- **Description (chapter "Description"):**

Describe the characteristics of the swimlane.

The description will be used for documentation purposes.

Geben Sie eine Beschreibung zur Schwimmbahn an.

Dient der Dokumentation.

- **Comment (chapter "Description"):**

Enter any comments about the swimlane.

The comments will be used for documentation purposes.

Geben Sie einen Kommentar zur Schwimmbahn an.

Dient der Dokumentation.

- **Open questions (chapter "Description"):**

Here you can enter any open questions which are still to be answered for the swimlane.

Hinterlegen Sie hier eventuell noch vorhandene offene Fragen zu dieser Schwimmbahn.

- **Color (chapter "Representation"):**

You can define the object color as follows:

- Select a color in the 'Color' window which can be opened by clicking on the dialog button (on the right above the attribute field).
- Enter a color name (e.g. 'cornflowerblue'; a list of the color names can be found in the user documentation or in the online help).
- Enter an hexadecimal value (e.g. '\$FFFFFF' for white), where the value begins with '\$' and contains the red, green and blue values with two digits for each.

Die Farbe des Objekts kann definiert werden durch:

- die Auswahl einer Farbe über das Fenster "Farben", welches Sie durch Anklicken des Dialog-Buttons (rechts oberhalb des Attributfelds) öffnen
- die Eingabe eines Farbnamens (z.B. "cornflowerblue"; eine Liste finden Sie in Benutzerdokumentation und Online-Hilfe)
- die Eingabe eines Hexadezimalwerts (z.B. "\$FFFFFF" für white/weiß), wobei der Wert mit '\$' beginnt und daran anschließend - jeweils zweistellig - die Rot-, Grün-, und Blauwerte beinhaltet

- **Display water marks (chapter "Representation"):**

Select, if the name of the swimlane should be visualized as a watermark. Using the watermark, the swimlane name will be repeated in the swimlane background periodically. The watermark helps reading large models.

Selektieren Sie, ob sie die Schwimmbahnbeschriftung auch als Wasserzeichen einblenden wollen. Mit Hilfe des Wasserzeichens wird die Schwimmbahnbeschriftung in periodischen Abständen im Schwimmbahnhintergrund dargestellt. Das Wasserzeichen hilft beim Lesen großer Modelle.

- **Alignment (chapter "Representation"):**

The alignment defines whether the name of the swimlane and the watermark will be visualized on top, centered or on the bottom of the swimlane.

Durch die Ausrichtung können Sie die Schwimmbahnbeschriftung und das Wasserzeichen am oberen Rand, zentriert oder am unteren Rand der Schwimmbahn anzeigen.

- **Bezeichnung (chapter "Deutsch"):**

Geben Sie eine Bezeichnung zur Schimmbahn ein. Dient der Dokumentation.

- **Beschreibung (chapter "Deutsch"):**

Geben Sie eine charakterisierende Beschreibung zur Schwimmbahn ein.
Dient der Dokumentation.

Describe the characteristics of the object.

The description will be used for documentation purposes.

- **Kommentar (chapter "Deutsch"):**

Geben Sie einen Kommentar zur Schwimmbahn ein.

Dient der Dokumentation.

 Enter any comments about the object.

The comments will be used for documentation purposes.

2.22 Class "Swimlane (vertical)" (ADONIS BPMS BP Library 3.9)

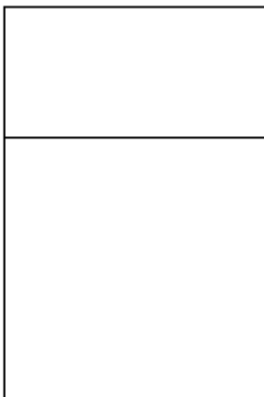

"Swimlanes" are areas of responsibilities (e.g. workgroups, units etc.) or represent IT System elements.

If a process is executed in different areas of responsibilities, each area becomes a swimlane on its own where each object can be placed according to its area.

In each swimlane the responsible role, performer, or organizational unit from the working environment or an IT system element from the IT system model can be referenced.

 "Schwimmbahnen" (engl. "swimlane") sind Verantwortlichkeitsbereiche (z.B. Arbeitsgruppen, Abteilungen etc.) oder repräsentieren IT systemelemente.

Läuft ein Prozeß in mehreren dieser Bereiche ab, so wird jeder Verantwortungsbereich in einer eigenen Schwimmbahn zusammengefasst und die entsprechenden Objekte des Geschäftsprozesses in dieser platziert.

In jeder Schwimmbahn kann die verantwortliche Rolle, der verantwortliche Bearbeiter, die verantwortliche Organisationseinheit aus einem Arbeitsumgebungsmodell oder ein IT systemelement aus einem IT-Systemmodell referenziert werden.

The following attributes are defined for the class "Swimlane (vertical)":

- **Name (chapter "Description"):**

- **Working environment (chapter "Description"):**

It is possible to reference an organizational element (role, performer or organizational unit) from a working environment model.

The reference can be selected or changed by clicking on the add-icon (symbol 'plus').

The name of the referenced organizational element will be displayed as a hyperlink on the upper border of the lane instead of the object name.

Referenzieren Sie ein Organisationselement (d.h. Rolle, Bearbeiter oder Organisationseinheit) aus einem Arbeitsumgebungsmodell.

Die Referenz wird über das Hinzufügen-Icon ('Plus'-Symbol) ausgewählt bzw. geändert.

Der Name des referenzierten Organisationselements wird als Hyperlink am oberen Rand der Schwimmbahn statt dem Objektnamen angezeigt.

- **Referenced IT system elements (chapter "Description"):**

It is possible to reference one application, infrastructure element or service in an IT System Model.

The reference can be selected or changed by clicking on the add-icon (symbol 'plus').

The name of the referenced IT System element will be displayed as a hyperlink on the left border of the lane instead of the object name unless some organizational elementattribute 'Working environment' is already referenced from this swimlane.

Referenzieren Sie hier eine Anwendung, ein Infrastrukturelement oder ein Service aus einem IT systemmodell.

Die Referenz wird über das Hinzufügen-Icon ('Plus'-Symbol) ausgewählt bzw. geändert.

Der Name des referenzierten IT systemelements wird als Hyperlink am linken Rand der Schwimmbahn statt dem Objektnamen angezeigt, sofern nicht bereits ein Organisationselement referenziert wird (Attribut 'Arbeitsumgebung').

- **Description (chapter "Description"):**

Describe the characteristics of the unit.

The description will be used for documentation purposes.

Geben Sie eine Beschreibung zur Schwimmbahn an.

Dient der Dokumentation.

- **Comment (chapter "Description"):**

Enter a comment for documentation purposes.

Geben Sie einen Kommentar zur Schwimmbahn an. Dient der Dokumentation.

- **Open questions (chapter "Description"):**

Here you can enter any open questions which are still to be answered for the swimlane.

Hinterlegen Sie hier eventuell noch vorhandene offene Fragen zu dieser Schwimmbahn.

- **Color (chapter "Representation"):**

You can define the object color as follows:

- Select a color in the 'Color' window which can be opened by clicking on the dialog button (on the right above the attribute field).

- Enter a color name (e.g. 'cornflowerblue'; a list of the color names can be found in the user documentation or in the online help).
 - Enter an hexadecimal value (e.g. '\$FFFFFF' for white), where the value begins with '\$' and contains the red, green and blue values with two digits for each.
-

Die Farbe des Objekts kann definiert werden durch:

- die Auswahl einer Farbe über das Fenster "Farben", welches Sie durch Anklicken des Dialog-Buttons (rechts oberhalb des Attributfelds) öffnen
- die Eingabe eines Farbnamens (z.B. "cornflowerblue"; eine Liste finden Sie in Benutzerdokumentation und Online-Hilfe)
- die Eingabe eines Hexadezimalwerts (z.B. "\$FFFFFF" für white/weiß), wobei der Wert mit '\$' beginnt und daran anschließend - jeweils zweistellig - die Rot-, Grün-, und Blauwerte beinhaltet

- **Display water marks (chapter "Representation"):**

Select if the name of the swimlane should be visualized as a watermark. Using the watermark, the swimlane name will be repeated in the swimlane background periodically. The watermark helps reading large models.

Selektieren Sie, ob sie die Schwimmbahnbeschriftung auch als Wasserzeichen einblenden wollen. Mit Hilfe des Wasserzeichens wird die Schwimmbahnbeschriftung in periodischen Abständen im Schwimmbahnhintergrund dargestellt. Das Wasserzeichen hilft beim Lesen großer Modelle.

- **Alignment (chapter "Representation"):**

The alignment defines whether the name of the swimlane and the watermark will be visualized on the left side, centered or on the right side of the swimlane.

Durch die Ausrichtung können Sie die Schwimmbahnbeschriftung und das Wasserzeichen am linken Rand, zentriert oder am rechten Rand der Schwimmbahn anzeigen.

- **Bezeichnung (chapter "Deutsch"):**

Geben Sie eine Bezeichnung zur Schimmbahn ein. Dient der Dokumentation.

- **Beschreibung (chapter "Deutsch"):**

Geben Sie eine charakterisierende Beschreibung zur Schwimmbahn ein.

Dient der Dokumentation.

Describe the characteristics of the object.

The description will be used for documentation purposes.

- **Kommentar (chapter "Deutsch"):**

Geben Sie einen Kommentar zur Schwimmbahn ein.

Dient der Dokumentation.

Enter any comments about the object.

The comments will be used for documentation purposes.

2.23 Class "External partner"



The External partner describes an interface or a business process, which is out of scope.

Der Externe Partner beschreibt eine Schnittstelle nach außen oder Geschäftsprozesse, welche außerhalb des Betrachtungsbereichs liegen.

The following attributes are defined for the class "External partner":

- **Name (chapter "Description"):**

- **Referenced organizational unit (chapter "Description"):**

It is possible to reference an organizational element (role, position, performer, organizational unit) from a working environment model, which is defined as an actor in the actual use case.

The reference can be selected or changed by clicking on the add-icon (symbol 'plus').

Referenzieren Sie ein Organisationselement (d.h. Rolle, Planstelle, Bearbeiter oder Organisationseinheit) aus einem Arbeitsumgebungsmodell, welches als Akteur im aktuellen Anwendungsfall definiert ist.

Die Referenz wird über das Hinzufügen-Icon ('Plus'-Symbol) ausgewählt bzw. geändert.

- **Description (chapter "Description"):**

Describe the characteristics of the External partner.

The description will be used for documentation purposes.

Geben Sie eine charakterisierende Beschreibung des externen Partners ein.

Dient der Dokumentation.

- **Comment (chapter "Description"):**

Enter any comments about the partner.

The comments will be used for documentation purposes.

Geben Sie einen Kommentar zum externen Partner ein.

Dient der Dokumentation.

- **Bezeichnung (chapter "Deutsch"):**

Enter a name.

For documentation purposes.

- **Beschreibung (chapter "Deutsch"):**

Geben Sie eine charakterisierende Beschreibung des externen Partners ein.

Dient der Dokumentation.

Describe the characteristics of the object.

The description will be used for documentation purposes.

- **Kommentar (chapter "Deutsch"):**

Geben Sie einen Kommentar zum externen Partner ein.

Dient der Dokumentation.

Enter any comments about the object.

The comments will be used for documentation purposes.

2.24 Class "Product"



Products are units to be sold for a certain price. These units may be either material or immaterial products or services.

Products can be composed from other products or product components.

Produkte sind verkaufbare Einheiten mit einem bestimmten Preis. Diese verkaufbaren Einheiten können sowohl materielle und immaterielle Produkte sein, als auch Dienstleistungen.

Produkte können sich aus anderen Produkten oder Produktkomponenten zusammensetzen.

The following attributes are defined for the class "Product":

- **Name (chapter "Description"):**

- **Description (chapter "Description"):**

Describe the characteristics of the product.

The description will be used for documentation purposes.

Geben Sie eine Beschreibung ein.

Dient der Dokumentenation.

- **Comment (chapter "Description"):**

Enter any comments about the product.

The comments will be used for documentation purposes.

Geben Sie einen Kommentar ein.

Dient der Dokumentation.

- **External documentation (chapter "Description"):**

The 'External documentation' allows the integration of existing information sources (documents, tables, graphics, intranet pages...) into the products of a product model.

The integration is carried out by entering the path and the file name in the field 'Program arguments'.

When entered, external documents are displayed by a document symbol on the right side above the object.

Die 'Externe Dokumentation' ermöglicht die Einbindung von bereits bestehenden Informationsquellen, wie Dokumente, Tabellen, Grafiken, Intranet-Seiten u.v.m. in die Produkte eines Produktmodells.

Die Einbindung erfolgt durch das Eintragen des Pfades und des Dateinamens im Feld 'Parameter'.

Eingetragene externe Dokumente werden durch ein Dokumenten-Symbol rechts oberhalb des Objekts angezeigt.

- **Open questions (chapter "Description"):**

Here you can enter any open questions which are still to be answered for this object.

If you enter any open questions, a red question mark appears above the object symbol on the drawing area.

Hinterlegen Sie hier eventuell noch vorhandene offene Fragen zu diesem Objekt.

Bei offenen Fragen erscheint auf der Zeichenoberfläche neben dem Objekt ein rotes Fragezeichen.

- **Total costs (chapter "Costs"):**

Total costs are the sum of product specific costs and all total costs of products and product components, which are connected with the product via the "has" relationship.

Die Gesamtkosten sind die Summe der spezifischen Kosten eines Produkts und aller Gesamtkosten der Produkte und Produktkomponenten, die über die Beziehung "hat" mit dem Produkt verbunden sind.

- **Specific costs (chapter "Costs"):**

Specific costs can be assigned directly to the product or they are caused directly by the product.

Die spezifischen Kosten sind direkt dem Produkt zurechenbare bzw. beim Produkt anfallende Kosten.

- **Display costs (chapter "Costs"):**

If this option is activated, the values of total costs and specific costs will be shown within the product symbol on the drawing area.

Falls diese Option aktiviert ist, werden die Werte der Gesamtkosten und der spezifischen Kosten im Produktsymbol auf der Zeichenfläche eingeblendet.

- **Product responsibility (chapter "References"):**

Select the role or person from the working environment which is responsible for the product.

Bestimmen Sie jene Rolle oder Person aus der Arbeitsumgebung, die für das Produkt verantwortlich ist.

- **Referenced product model (chapter "References"):**

It is possible to reference a product model to refine the current product in a new product model.

The reference can be selected or changed by clicking on the add-icon (symbol 'plus').

Referenzieren Sie ein Produktmodell zur Verfeinerung des aktuellen Produkts in einem weiteren Produktmodell.

Die Referenz wird über das Hinzufügen-Icon ('Plus'-Symbol) ausgewählt bzw. geändert.

- **Referenced documents (chapter "References"):**

It is possible to reference one or more documents in a document model.

Referenzieren Sie hier ein oder mehrere Dokumente aus einem Dokumentenmodell.

- **Referenced processes (chapter "References"):**

It is possible to reference one or more business process models, which are necessary to work on the product.

The reference can be selected or changed by clicking on the add-icon (symbol 'plus').

Referenzieren Sie ein oder mehrere Geschäftsprozesse, die für die Bearbeitung des Produkts notwendig sind.

Die Referenz wird über das Hinzufügen-Icon ('Plus'-Symbol) ausgewählt bzw. geändert.

- **Referenced IT system elements (chapter "References"):**

It is possible to reference IT system elements (application, service or infrastructure element) from an IT system model, which are required for the description of the product.

The reference can be selected or changed by the add-icon (symbol 'plus').

Referenzieren Sie jene IT systemelemente (d.h. Anwendung, Service oder Infrastrukturelement) aus einem IT systemmodell, welche für die Beschreibung des Produkts notwendig sind.

Die Referenz wird über das Hinzufügen-Icon ('Plus'-Symbol) ausgewählt bzw. geändert.

- **Bezeichnung (chapter "Deutsch"):**

Enter a name.

For documentation purposes.

- **Beschreibung (chapter "Deutsch"):**

Describe the characteristics of the object.

The description will be used for documentation purposes.

Geben Sie eine Beschreibung ein.

Dient der Dokumentation.

- **Kommentar (chapter "Deutsch"):**

Geben Sie einen Kommentar ein.

Dient der Dokumentation.

Enter any comments about the object.

The comments will be used for documentation purposes.

2.25 Class "Product component"



Product components are parts or properties of a product. Product components usually have direct assigned costs.

They are only be sold in combination with a product.

Produktkomponenten repräsentieren Bestandteile oder Eigenschaften eines Produkts. Produktkomponenten haben meist einen direkt zurechenbaren Preis. Sie sind jedoch keine eigenständig verkaufbaren Einheiten, sondern werden nur als Bestandteil eines Produkts verkauft.

The following attributes are defined for the class "Product component":

- **Name (chapter "Description"):**

- **Description (chapter "Description"):**

Describe the characteristics of the object.

The description will be used for documentation purposes.

Geben Sie eine Beschreibung ein.

Dient der Dokumentenation.

- **Comment (chapter "Description"):**

Geben Sie einen Kommentar ein.

Dient der Dokumentation.

Enter any comments about the object.

The comments will be used for documentation purposes.

- **External documentation (chapter "Description"):**

The attribute 'external documentation' allows the integration of existing information sources (documents, tables, graphics, intranet pages...) into the product components of a product model.

The integration is carried out by entering the path and the file name in the field 'Program arguments'.

When entered, external documents are displayed by a document symbol on the right side above the object.

Die 'Externe Dokumentation' ermöglicht die Einbindung von bereits bestehenden Informationsquellen, wie Dokumente, Tabellen, Grafiken, Intranet-Seiten u.v.m. in die Produktkomponenten eines Produktmodells.

Die Einbindung erfolgt durch das Eintragen des Pfades und des Dateinamens im Feld 'Parameter'.

Eingetragene externe Dokumente werden durch ein Dokumenten-Symbol rechts oberhalb des Objekts angezeigt.

- **Open questions (chapter "Description"):**

Here you can enter any open questions which are still to be answered for this object.

If you enter any open questions, a red question mark appears above the object symbol on the drawing area.

Hinterlegen Sie hier eventuell noch vorhandene offene Fragen zu diesem Objekt.

Bei offenen Fragen erscheint auf der Zeichenoberfläche neben dem Objekt ein rotes Fragezeichen.

- **Total costs (chapter "Costs"):**

Total costs are the sum of product component specific costs and all total costs of products and product components, which are connected with the product component via the "has" relationship.

Die Gesamtkosten sind die Summe der spezifischen Kosten einer Produktkomponente und aller Gesamtkosten der Produkte und Produktkomponenten, die über die Beziehung "hat" mit der Produktkomponente verbunden sind.

- **Specific costs (chapter "Costs"):**

Specific costs are costs that are assigned directly to the product component or they are caused directly by the product component.

Die spezifischen Kosten sind direkt der Produktkomponente zurechenbare bzw. bei der Produktkomponente anfallende Kosten.

- **Display costs (chapter "Costs"):**

If this option is activated, the values of total costs and specific costs will be shown within the product component symbol on the drawing area.

Falls diese Option aktiviert ist, werden die Werte der Gesamtkosten und der spezifischen Kosten im Produktkomponentensymbol auf der Zeichenfläche eingeblendet.

- **Component responsibility (chapter "References"):**

Select the role or person from the working environment which is responsible for the product component.

Bestimmen Sie jene Rolle oder Person aus der Arbeitsumgebung, die für die Produktkomponente verantwortlich ist.

- **Referenced product model (chapter "References"):**

It is possible to reference a product model to refine the current product component in a new product model.

The reference can be selected or changed by clicking on the add-icon (symbol 'plus').

Referenzieren Sie ein Produktmodell zur Verfeinerung der aktuellen Produktkomponente in einem weiteren Produktmodell.

Die Referenz wird über das Hinzufügen-Icon ('Plus'-Symbol) ausgewählt bzw. geändert.

- **Referenced documents (chapter "References"):**

It is possible to reference one or more documents in a document model from this attribute.

Referenzieren Sie hier ein oder mehrere Dokumente aus einem Dokumentenmodell.

- **Referenced processes (chapter "References"):**

It is possible to reference one or more business process models, which are necessary to work on the product component.

The reference can be selected or changed by clicking on the add-icon (symbol 'plus').

Referenzieren Sie ein oder mehrere Geschäftsprozesse, die für die Bearbeitung der Produktkomponente notwendig sind.

Die Referenz wird über das Hinzufügen-Icon ('Plus'-Symbol) ausgewählt bzw. geändert.

- **Referenced IT system elements (chapter "References"):**

It is possible to reference IT system elements (application, service or infrastructure element) from an IT system model, which are required for the description of the product.

The reference can be selected or changed by clicking on the add-icon (symbol 'plus').

Referenzieren Sie jene IT systemelemente (d.h. Anwendung, Service oder Infrastrukturelement) aus einem IT systemmodell, welche für die Beschreibung des Produkts notwendig sind.

Die Referenz wird über das Hinzufügen-Icon ('Plus'-Symbol) ausgewählt bzw. geändert.

- **Bezeichnung (chapter "Deutsch"):**

Enter a name.

For documentation purposes.

- **Beschreibung (chapter "Deutsch"):**

Enter any comments about the object.

The comments will be used for documentation purposes.

Geben Sie eine Beschreibung ein.

Dient der Dokumentation.

- **Kommentar (chapter "Deutsch"):**

Enter any comments about the object.

For documentation purposes.

Geben Sie einen Kommentar ein.

Dient der Dokumentation.

2.26 Class "Application"

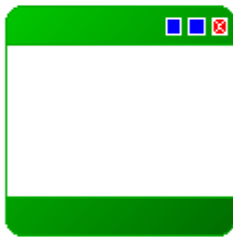

An application represents software which is used in the execution of business processes or in the work on products.

Eine Anwendung repräsentiert Software, welche für die Durchführung von Geschäftsprozessen oder der Bearbeitung von Produkten benötigt wird.

The following attributes are defined for the class "Application":

- **Name (chapter "Description"):**

- **Version (chapter "Description"):**

Geben Sie hier die Version der Anwendung ein.

Enter the version of the application.

- **Description (chapter "Description"):**

Describe the characteristics of the object.

The description will be used for documentation purposes.

Geben Sie eine Beschreibung ein.

Dient der Dokumentenation.

- **Comment (chapter "Description"):**

Enter any comments about the object.

The comments will be used for documentation purposes.

Geben Sie einen Kommentar ein.

Dient der Dokumentation.

- **Application responsibility (chapter "Description"):**

It is possibl to reference a role from a working environment model, which is responsible for the application.

The reference can be selected or changed by clicking on the add-icon (symbol 'plus').

Referenzieren Sie jene Rolle aus einem Arbeitsumgebungsmodell, welche für die Anwendung verantwortlich ist.

Die Referenz wird über das Hinzufügen-Icon ('Plus'-Symbol) ausgewählt bzw. geändert.

- **Type of application (chapter "Description"):**

Select the type of application from the predefined menu.

Wählen Sie den Typ der Anwendung aus der vorgegebenen Auswahl aus.

- **Other (chapter "Description"):**

Enter the type of the application, if no value from the predefined selection of the attribute "application type" is suitable.

Geben Sie hier den Typ der Anwendung ein, falls kein Wert aus der Auswahlliste des Attributs "Anwendungstyp" passend ist.

- **Screenshot (chapter "Description"):**

Select an image file which will be shown within the application symbol on the drawing area.

Wählen Sie eine Grafikdatei aus, die im Anwendungssymbol auf der Zeichenfläche visualisiert wird.

- **External documentation (chapter "Description"):**

The attribute 'external documentation' allows the integration of existing information sources (documents, tables, graphics, intranet pages...) into the applications of an IT system model.

The integration is carried out by entering the path and the file name in the field 'Program arguments'.

When entered, external documents are displayed by a document symbol on the right side above the object.

Die 'Externe Dokumentation' ermöglicht die Einbindung von bereits bestehenden Informationsquellen, wie Dokumente, Tabellen, Grafiken, Intranet-Seiten u.v.m. in die Anwendungen eines IT systemmodells.

Die Einbindung erfolgt durch das Eintragen des Pfades und des Dateinamens im Feld 'Parameter'.

Eingetragene externe Dokumente werden durch ein Dokumenten-Symbol rechts oberhalb des Objekts angezeigt.

- **Referenced documents (chapter "Description"):**

It is possible to reference documents from a document model, which are required for the description of the application.

The reference can be selected or changed by clicking on the add-icon (symbol 'plus').

When entered, referenced documents are displayed by a document symbol on the right side above the object.

Referenzieren Sie jene Dokumente aus einem Dokumentenmodell, welche für die Beschreibung der Anwendung notwendig sind.

Die Referenz wird über das Hinzufügen-Icon ('Plus'-Symbol) ausgewählt bzw. geändert.

Eingetragene referenzierte Dokumente werden durch ein Dokumenten-Symbol rechts oberhalb des Objekts angezeigt.

- **Open questions (chapter "Description"):**

Here you can enter any open questions which are still to be answered for this object.

If you enter any open questions, a red question mark appears above the object symbol on the drawing area.

Hinterlegen Sie hier eventuell noch vorhandene offene Fragen zu diesem Objekt.

Bei offenen Fragen erscheint auf der Zeichenoberfläche neben dem Objekt ein rotes Fragezeichen.

- **Referenced IT system model (chapter "Description"):**

It is possible to reference an IT system model, which shows the actual application in a detailed form.

The reference can be selected or changed by clicking on the add-icon (symbol 'plus').

When a reference is entered, an arrow symbol is displayed in the right lower part of the object.

You can navigate into the referenced sub-model by clicking this symbol.

Referenzieren Sie ein IT systemmodell, in welchem die aktuelle Anwendung in detaillierter Form dargestellt ist.

Die Referenz wird über das Hinzufügen-Icon ('Plus'-Symbol) ausgewählt bzw. geändert.

Bei eingetragener Referenz wird ein Pfeil-Symbol rechts unten im Objekt angezeigt.

Über dieses Pfeil-Symbol kann durch Anklicken in das referenzierte Submodell navigiert werden.

- **Input (chapter "Input/Output"):**

It is possible to reference documents from a document model, which are used as input for the application.

The reference can be selected or changed by clicking on the add-icon (symbol 'plus').

Referenzieren Sie jene Dokumente aus einem Dokumentenmodell, welche Input für die Anwendung sind.

Die Referenz wird über das Hinzufügen-Icon ('Plus'-Symbol) ausgewählt bzw. geändert.

- **Output (chapter "Input/Output"):**

It is possible to reference documents from a document model, which are created as output from an application.

The reference can be selected or changed by clicking on the add-icon (symbol 'plus').

Referenzieren Sie jene Dokumente aus einem Dokumentenmodell, welche Output der Anwendung sind.

Die Referenz wird über das Hinzufügen-Icon ('Plus'-Symbol) ausgewählt bzw. geändert.

- **Properties (chapter "Properties"):**

Enter the individual properties of the application and their values.

Hinterlegen Sie hier die individuellen Eigenschaften der Anwendung und deren Werte.

- **Bezeichnung (chapter "Deutsch"):**

Enter a name.

For documentation purposes.

- **Description (chapter "Deutsch"):**

Describe the characteristics of the object.

The description will be used for documentation purposes.

Geben Sie eine Beschreibung ein.

Dient der Dokumentenation.

- **Comment (chapter "Deutsch"):**

Enter any comments about the object.

The comments will be used for documentation purposes.

Geben Sie einen Kommentar ein.

Dient der Dokumentation.

2.27 Class "Service"



A service represents and delivers the functionality of an application or an IT system to a requester. A special kind of services are web services.

Ein Service repräsentiert einen Dienst, der Funktionen einer Anwendung oder eines IT systems zur Verfügung stellt. Eine spezielle Form von Diensten sind Web Services.

The following attributes are defined for the class "Service":

- **Name (chapter "Description"):**

- **Version (chapter "Description"):**

Enter the version of the service.

Geben Sie hier die Version des Service ein.

- **Description (chapter "Description"):**

Describe the characteristics of the object.

The description will be used for documentation purposes.

Geben Sie eine Beschreibung ein.

Dient der Dokumentenation.

- **Comment (chapter "Description"):**

Enter any comments about the object.

The comments will be used for documentation purposes.

Geben Sie einen Kommentar ein.

Dient der Dokumentation.

- **Service responsibility (chapter "Description"):**

It is possible to reference a role from a working environment model, which is responsible for the service.

The reference can be selected or changed by clicking on the add-icon (symbol 'plus').

Referenzieren Sie jene Rolle aus einem Arbeitsumgebungsmodell, welche für das Service verantwortlich ist.

Die Referenz wird über das Hinzufügen-Icon ('Plus'-Symbol) ausgewählt bzw. geändert.

- **Screenshot (chapter "Description"):**

Select an image file which will be shown within the service symbol on the drawing area.

Wählen Sie eine Grafikdatei aus, die im Servicesymbol auf der Zeichenfläche visualisiert wird.

- **External documentation (chapter "Description"):**

The attribute 'external documentation' allows the integration of existing information sources (documents, tables, graphics, intranet pages...) into the services of an IT system model.

The integration is carried out by entering the path and the file name in the field 'Program arguments'.

When entered, external documents are displayed by a document symbol on the right side above the object.

Die 'Externe Dokumentation' ermöglicht die Einbindung von bereits bestehenden Informationsquellen, wie Dokumente, Tabellen, Grafiken, Intranet-Seiten u.v.m. in die Services eines IT systemmodells.

Die Einbindung erfolgt durch das Eintragen des Pfades und des Dateinamens im Feld 'Parameter'.

Eingetragene externe Dokumente werden durch ein Dokumenten-Symbol rechts oberhalb des Objekts angezeigt.

- **Referenced documents (chapter "Description"):**

It is possible to reference documents from a document model, which are required for the description of the service.

The reference can be selected or changed by clicking on the add-icon (symbol 'plus').

When entered, referenced documents are displayed by a document symbol on the right side above the object.

Referenzieren Sie jene Dokumente aus einem Dokumentenmodell, welche für die Beschreibung des Service notwendig sind.

Die Referenz wird über das Hinzufügen-Icon ('Plus'-Symbol) ausgewählt bzw. geändert.

Eingetragene referenzierte Dokumente werden durch ein Dokumenten-Symbol rechts oberhalb des Objekts angezeigt.

- **Open questions (chapter "Description"):**

Here you can enter any open questions which are still to be answered for this object.

If you enter any open questions, a red question mark appears above the object symbol on the drawing area.

Hinterlegen Sie hier eventuell noch vorhandene offene Fragen zu diesem Objekt.

Bei offenen Fragen erscheint auf der Zeichenoberfläche neben dem Objekt ein rotes Fragezeichen.

- **Referenced IT system model (chapter "Description"):**

It is possible to reference an IT system model, which shows the actual service in a detailed form.

The reference can be selected or changed by clicking on the add-icon (symbol 'plus').

When a reference is entered, an arrow symbol is displayed in the right lower part of the object.

You can navigate into the referenced sub-model by clicking this symbol.

Referenzieren Sie ein IT systemmodell, in welchem das aktuelle Service in detaillierter Form dargestellt ist.

Die Referenz wird über das Hinzufügen-Icon ('Plus'-Symbol) ausgewählt bzw. geändert.

Bei eingetragener Referenz wird ein Pfeil-Symbol rechts unten im Objekt angezeigt.

Über dieses Pfeil-Symbol kann durch Anklicken in das referenzierte Submodell navigiert werden.

- **Input (chapter "Input/Output"):**

It is possible to reference documents from a document model, which are used as input for the service.

The reference can be selected or changed by clicking on the add-icon (symbol 'plus').

Referenzieren Sie jene Dokumente aus einem Dokumentenmodell, welche Input für das Service sind.

Die Referenz wird über das Hinzufügen-Icon ('Plus'-Symbol) ausgewählt bzw. geändert.

- **Output (chapter "Input/Output"):**

It is possible to reference documents from a document model, which are the output from the service.

The reference can be selected or changed by clicking on the add-icon (symbol 'plus').

Referenzieren Sie jene Dokumente aus einem Dokumentenmodell, welche Output des Service sind.

Die Referenz wird über das Hinzufügen-Icon ('Plus'-Symbol) ausgewählt bzw. geändert.

- **Properties (chapter "Properties"):**

Enter the individual properties of the service and their values.

Hinterlegen Sie hier die individuellen Eigenschaften des Service und deren Werte.

- **Bezeichnung (chapter "Deutsch"):**

Enter a name.

For documentation purposes.

- **Beschreibung (chapter "Deutsch"):**

Geben Sie eine Beschreibung ein.

Dient der Dokumentenation.

Describe the characteristics of the object.

The description will be used for documentation purposes.

- **Kommentar (chapter "Deutsch"):**

Geben Sie einen Kommentar ein.

Dient der Dokumentation.

Enter any comments about the object.

The comments will be used for documentation purposes.

2.28 Class "Performance"



The performance symbol represents either results of a business process (output) or prerequisites for executing a business process.

Eine Leistung ist das Ergebnis eines Geschäftsprozesses (Output) oder die Voraussetzung zur Durchführung eines Geschäftsprozesses (Input).

The following attributes are defined for the class "Performance":

- **Name (chapter "Description"):**

- **Referenced element (chapter "Description"):**

It is possible to reference an element (document from a document model, product or product component from a product model or application, service and infrastructure element respectively from an IT-system model).

The reference can be selected or changed by clicking on the add-icon (symbol 'plus').

The name of the referenced element will be displayed as a hyperlink in the object instead of the object name.

Referenzieren Sie ein Element (Dokument aus einem Dokumentenmodell, Produkt oder Produktkomponente aus einem Produktmodell oder Anwendung, Service bzw. Infrastrukturelement aus einem IT systemmodell).

Die Referenz wird über das Hinzufügen-Icon ('Plus'-Symbol) ausgewählt bzw. geändert.

Der Name des referenzierten Elements wird als Hyperlink im Objekts statt dem Objektnamen angezeigt.

- **Description (chapter "Description"):**

Describe the characteristics of the object.

The description will be used for documentation purposes.

Geben Sie eine Beschreibung ein.

Dient der Dokumentenation.

- **Comment (chapter "Description"):**

Enter any comments about the object.

The comments will be used for documentation purposes.

Geben Sie einen Kommentar ein.

Dient der Dokumentation.

- **External documentation (chapter "Description"):**

The attribute 'external documentation' allows the integration of existing information sources (documents, tables, graphics, intranet pages...) into the performance of a process map.

The integration is carried out by entering the path and the file name in the field 'Program arguments'.

When entered, external documents are displayed by a document symbol on the right side above the object.

Die "Externe Dokumentation" ermöglicht die Einbindung von bestehenden Informationsquellen (Dokumente, Tabellen, Grafiken, Intranet-Seiten ...) in die Leistungen einer Prozeßlandkarte.

Die Einbindung erfolgt durch das Eintragen des Pfades und des Dateinamens im Feld 'Parameter'.

Eingetragene externe Dokumente werden durch ein Dokumenten-Symbol rechts oberhalb des Objekts angezeigt.

- **Referenced documents (chapter "Description"):**

It is possible to reference documents from a document model, which are required for the description of the performance.

The reference can be selected or changed by clicking on the add-icon (symbol 'plus').

When entered, referenced documents are displayed by a document symbol on the right side above the object.

Referenzieren Sie jene Dokumente aus einem Dokumentenmodell, welche für die Beschreibung der Leistung notwendig sind.

Die Referenz wird über das Hinzufügen-Icon ('Plus'-Symbol) ausgewählt bzw. geändert.

Eingetragene referenzierte Dokumente werden durch ein Dokumenten-Symbol rechts oberhalb des Objekts angezeigt.

- **Open questions (chapter "Description"):**

Here you can enter any open questions which are still to be answered for this object.

If you enter any open questions, a red question mark appears above the object symbol on the drawing area.

Hinterlegen Sie hier eventuell noch vorhandene offene Fragen zu diesem Objekt.

Bei offenen Fragen erscheint auf der Zeichenoberfläche neben dem Objekt ein rotes Fragezeichen.

- **Bezeichnung (chapter "Deutsch"):**

Enter a name.

For documentation purposes.

- **Beschreibung (chapter "Deutsch"):**

Geben Sie eine Beschreibung ein.

Dient der Dokumentation.

Describe the characteristics of the object.

The description will be used for documentation purposes.

- **Kommentar (chapter "Deutsch"):**

Geben Sie einen Kommentar ein.

Dient der Dokumentation.

Enter any comments about the object.

The comments will be used for documentation purposes.

2.29 Class "Infrastructure element"



An infrastructure element represents resources within the IT infrastructure which are necessary to execute applications and services.

Ein Infrastrukturelement repräsentiert Ressourcen der informationstechnischen Infrastruktur, die für die Durchführung von Anwendungen und Services benötigt werden.

The following attributes are defined for the class "Infrastructure element":

- **Name (chapter "Description"):**

- **Version (chapter "Description"):**

Enter the version of the infrastructure element.

Geben Sie hier die Version des Infrastrukturelements ein.

- **Description (chapter "Description"):**

Describe the characteristics of the object.

The description will be used for documentation purposes.

Geben Sie eine Beschreibung ein.

Dient der Dokumentenation.

- **Comment (chapter "Description"):**

Enter any comments about the object.

The comments will be used for documentation purposes.

Geben Sie einen Kommentar ein.

Dient der Dokumentation.

- **Service responsibility (chapter "Description"):**

It is possible to reference a role from a working environment model, which is responsible for the infrastructure element.

The reference can be selected or changed by clicking on the add-icon (symbol 'plus').

Referenzieren Sie jene Rolle aus einem Arbeitsumgebungsmodell, welche für das Infrastrukturelement verantwortlich ist.

Die Referenz wird über das Hinzufügen-Icon ('Plus'-Symbol) ausgewählt bzw. geändert.

- **Screenshot (chapter "Description"):**

Select an image file which will be shown within the infrastructure element symbol on the drawing area.

Wählen Sie eine Grafikdatei aus, die im Infrastrukturelement auf der Zeichenfläche visualisiert wird.

- **External documentation (chapter "Description"):**

The attribute 'external documentation' allows the integration of existing information sources (documents, tables, graphics, intranet pages...) into the infrastructure elements of an IT system model.

The integration is carried out by entering the path and the file name in the field 'Program arguments'.

When entered, external documents are displayed by a document symbol on the right side above the object.

Die 'Externe Dokumentation' ermöglicht die Einbindung von bereits bestehenden Informationsquellen, wie Dokumente, Tabellen, Grafiken, Intranet-Seiten u.v.m. in die Infrastrukturelemente eines IT systemmodells.

Die Einbindung erfolgt durch das Eintragen des Pfades und des Dateinamens im Feld 'Parameter'.

Eingetragene externe Dokumente werden durch ein Dokumenten-Symbol rechts oberhalb des Objekts angezeigt.

- **Referenced documents (chapter "Description"):**

It is possible to reference documents from a document model, which are required for the description of the infrastructure element.

The reference can be selected or changed by clicking on the add-icon (symbol 'plus').

When entered, referenced documents are displayed by a document symbol on the right side above the object.

Referenzieren Sie jene Dokumente aus einem Dokumentenmodell, welche für die Beschreibung des Infrastrukturelements notwendig sind.

Die Referenz wird über das Hinzufügen-Icon ('Plus'-Symbol) ausgewählt bzw. geändert.

Eingetragene referenzierte Dokumente werden durch ein Dokumenten-Symbol rechts oberhalb des Objekts angezeigt.

- **Open questions (chapter "Description"):**

Here you can enter any open questions which are still to be answered for this object.

If you enter any open questions, a red question mark appears above the object symbol on the drawing area.

Hinterlegen Sie hier eventuell noch vorhandene offene Fragen zu diesem Objekt.

Bei offenen Fragen erscheint auf der Zeichenoberfläche neben dem Objekt ein rotes Fragezeichen.

- **Referenced IT system model (chapter "Description"):**

It is possible to reference an IT system model, which shows the actual infrastructure element in a detailed form.

The reference can be selected or changed by clicking on the add-icon (symbol 'plus').

When a reference is entered, an arrow symbol is displayed in the right lower part of the object.

You can navigate into the referenced sub-model by clicking this symbol.

Referenzieren Sie ein IT systemmodell, in welchem das aktuelle Infrastrukturelement in detaillierter Form dargestellt ist.

Die Referenz wird über das Hinzufügen-Icon ('Plus'-Symbol) ausgewählt bzw. geändert.

Bei eingetragener Referenz wird ein Pfeil-Symbol rechts unten im Objekt angezeigt.

Über dieses Pfeil-Symbol kann durch Anklicken in das referenzierte Submodell navigiert werden.

- **Input (chapter "Input/Output"):**

It is possible to reference documents from a document model, which are used as input for the infrastructure element.

The reference can be selected or changed by clicking on the add-icon (symbol 'plus').

Referenzieren Sie jene Dokumente aus einem Dokumentenmodell, welche Input für das Infrastrukturelement sind.

Die Referenz wird über das Hinzufügen-Icon ('Plus'-Symbol) ausgewählt bzw. geändert.

- **Output (chapter "Input/Output"):**

It is possible to reference documents from a document model, which are the output from the infrastructure element.

The reference can be selected or changed by clicking on the add-icon (symbol 'plus').

Referenzieren Sie jene Dokumente aus einem Dokumentenmodell, welche Output des Infrastrukturelements sind.

Die Referenz wird über das Hinzufügen-Icon ('Plus'-Symbol) ausgewählt bzw. geändert.

- **Properties (chapter "Properties"):**

Enter the individual properties of the infrastructure element and their values.

Hinterlegen Sie hier die individuellen Eigenschaften des Infrastrukturelements und deren Werte.

- **Bezeichnung (chapter "Deutsch"):**

Enter a name.

For documentation purposes.

- **Beschreibung (chapter "Deutsch"):**

Geben Sie eine Beschreibung ein.

Dient der Dokumentenation.

Describe the characteristics of the object.

The description will be used for documentation purposes.

- **Kommentar (chapter "Deutsch"):**

Geben Sie einen Kommentar ein.

Dient der Dokumentation.

Enter any comments about the object.

The comments will be used for documentation purposes.

2.30 Class "Cross-reference"



A cross-reference is a pointer to any model and represents a navigation aid, especially in large model bases.

Ein Querverweis ist ein Zeiger auf ein beliebiges Modell und stellt eine Navigationshilfe dar, insbesondere in komplexen Modellbeständen.

The following attributes are defined for the class "Cross-reference":

- **Name (chapter "Description"):**

- **Cross-reference (chapter "Description"):**

Reference any model to define an interdependency.

The reference can be selected or changed by clicking on the add-icon (symbol 'plus').

Referenzieren Sie ein beliebiges Modell, um eine Abhängigkeit festzulegen.

Die Referenz wird über das Hinzufügen-Icon ('Plus'-Symbol) ausgewählt bzw. geändert.

- **Type of Cross-reference (chapter "Description"):**

Enter whether this is an incoming or outgoing cross-reference.

An incoming cross-reference represents input, an outgoing cross-reference represents output.

Geben Sie an ob es sich um einen eingehenden oder ausgehenden Querverweis handelt.

Eingehende Querverweise stellen Inputs, ausgehende Querverweise Outputs dar.

- **Description (chapter "Description"):**

Describe the characteristics of the object.

The description will be used for documentation purposes.

Geben Sie eine Beschreibung ein.

Dient der Dokumentenation.

- **Comment (chapter "Description"):**

Enter any comments about the object.

The comments will be used for documentation purposes.

Geben Sie einen Kommentar ein.

Dient der Dokumentation.

- **Bezeichnung (chapter "Deutsch"):**

Enter a name.

For documentation purposes.

- **Beschreibung (chapter "Deutsch"):**

Geben Sie eine Beschreibung ein.

Dient der Dokumentenation.

Describe the characteristics of the object.

The description will be used for documentation purposes.

- **Kommentar (chapter "Deutsch"):**

Geben Sie einen Kommentar ein.

Dient der Dokumentation.

Enter any comments about the object.

The comments will be used for documentation purposes.

2.31 Class "Organizational unit"



The object "Organizational unit" allows you to show the hierarchy of the working environment.

- Performers belong to an organizational unit,

Part III

- an organizational unit can have a manager,
 - an organizational unit can be subordinated to other organizational unit(s),
 - an organizational unit can have one or more resources.
-

Das Einbinden von Organisationseinheiten ermöglicht es Ihnen, die Hierarchie Ihrer Arbeitsumgebung übersichtlich darzustellen.

- Einer Organisationseinheit gehören Bearbeiter an
- Eine Organisationseinheit kann einen Leiter haben
- Eine Organisationseinheit kann anderen Organisationseinheiten übergeordnet sein
- Eine Organisationseinheit kann eine oder mehrere Ressourcen haben

The following attributes are defined for the class "Organizational unit":

- **Name (chapter "Description"):**

- **Order (chapter "Description"):**

This attribute can be set with the help of the 'Object numbering' function, which numbers the objects of the business process model.

This can be useful for example within the component 'Documentation', to ensure that all objects are documented in the required order.

Dieses Attribut kann mit Hilfe der Numerierungsfunktion, mit der die ORG-Einheiten des Arbeitsumgebungsmodells numeriert werden, belegt werden.

Die Reihenfolge wird beispielsweise bei Verwendung der Zusatzkomponente "Dokumentationskomponente" herangezogen, um die Objekte in gewünschter Abfolge zu dokumentieren.

- **Description (chapter "Description"):**

Describe the characteristics of the organizational unit..

The description will be used for documentation purposes.

Geben Sie eine charakterisierende Beschreibung der Organisationseinheit an.

Dient der Dokumentation.

- **Comment (chapter "Description"):**

Enter any comments about the organizational unit.

The comments will be used for documentation purposes.

Geben Sie einen Kommentar zur Organisationseinheit an.

Dient der Dokumentation.

- **Model reference (chapter "Description"):**

Reference a working environment model, which shows the actual organizational unit in a detailed form.

The reference can be selected or changed by clicking on the add-icon (symbol 'plus').

The name of the referenced working environment model will be displayed as a hyperlink instead of the object name.

Referenzieren Sie ein Arbeitsumgebungsmodell, in welchem die aktuelle Organisationseinheit in detaillierter Form dargestellt ist.

Die Referenz wird über das Hinzufügen-Icon ('Plus'-Symbol) ausgewählt bzw. geändert.

Der Name des referenzierten Arbeitsumgebungsmodell wird als Hyperlink statt dem Objektnamen angezeigt.

- **Type (chapter "Information about organizational unit"):**

Select a type of the organizational unit based on the entries in the selection list. For function units the attribute must be empty.

Using the ADOorg component this attribute can be selected automatically.

Bestimmen Sie den Typ der Organisationseinheit anhand der Einträge in der Auswahlliste. Bei Stabstellen muss dieses Attribut leer bleiben.

Bei Verwendung der ADOorg Komponente wird dieses Attribut automatisch befüllt.

- **Functional unit (chapter "Information about organizational unit"):**

For functional units the attribute should be set to 'yes'.

Using the ADOorg component this attribute can be set automatically.

Bei Stabstellen muss dieses Attribut auf 'ja' gesetzt werden.

Bei Verwendung der ADOorg Komponente wird dieses Attribut automatisch gesetzt.

- **Cost center (chapter "Information about organizational unit"):**

Enter the cost center of the organizational unit.

Using the ADOorg component this attribute can be filled in automatically.

Geben Sie die Kostenstelle der Organisationseinheit an.

Bei Verwendung der ADOorg Komponente wird dieses Attribut automatisch befüllt.

- **Referenced organigram (chapter "Information about organizational unit"):**

It is possible to reference a working environment model, which shows the actual organizational unit in a detailed form.

The reference can be selected or changed by clicking on the add-icon (symbol 'plus').

When a reference is entered, an arrow symbol is displayed in the right lower part of the object.

You can navigate into the referenced sub-model by clicking this symbol.

Referenzieren Sie ein Arbeitsumgebungsmodell, in welchem die aktuelle Organisationseinheit in detaillierter Form dargestellt ist.

Die Referenz wird über das Hinzufügen-Icon ('Plus'-Symbol) ausgewählt bzw. geändert.

Bei eingetragener Referenz wird ein Pfeil-Symbol rechts unten im Objekt angezeigt.

Über dieses Pfeil-Symbol kann durch Anklicken in das referenzierte Submodell navigiert werden.

- **Organigram variant (chapter "Information about organizational unit"):**

- **Manager (chapter "Additional information"):**

Enter the head of the organizational unit.

Using the ADOorg component this attribute can be filled in automatically.

Geben Sie den Leiter der Organisationseinheit an.

Bei Verwendung der ADOorg Komponente wird dieses Attribut automatisch befüllt.

- **Function (chapter "Additional information"):**

Enter the function of the head of the organizational unit.

Using the ADOorg component this attribute can be filled in automatically.

Geben Sie die Funktion des Leiters der Organisationseinheit an.

Bei Verwendung der ADOorg Komponente wird dieses Attribut automatisch befüllt.

- **Planned number of positions (Org.- absolute) (chapter "Indicators for organizational unit"):**

Enter the planned number of the positions of the organizational unit.

Using the ADOorg component this attribute can be filled in automatically.

Geben Sie die geplante Anzahl der Planstellen der Organisationseinheit an.

Bei Verwendung der ADOorg Komponente wird dieses Attribut automatisch befüllt.

- **Number of occupied positions (Org.- absolute) (chapter "Indicators for organizational unit"):**

Enter the number of the occupied positions of the organizational unit.

Using the ADOorg component this attribute can be filled in automatically.

Geben Sie die Anzahl der besetzten Planstellen der Organisationseinheit an.

Bei Verwendung der ADOorg Komponente wird dieses Attribut automatisch befüllt.

- **Number of open positions (Org.- absolute) (chapter "Indicators for organizational unit"):**

Calculated number of the vacant positions of the organizational unit.

Ermittelte Anzahl der offenen Planstellen der Organisationseinheit.

- **Planned number of positions (Org.- relative) (chapter "Indicators for organizational unit"):**

Enter the planned capacity related number of the positions of the organizational unit.

Using the ADOorg component this attribute can be filled in automatically.

 Enter the planned capacity related number of the positions of the organizational unit.

Using the ADOorg component this attribute can be filled in automatically.

- **Number of occupied positions (Org.- relative) (chapter "Indicators for organizational unit"):**

Enter the capacity related number of the occupied positions of the organizational unit.

Using the ADOorg component this attribute can be filled in automatically.

 Geben Sie die kapazitätsbezogene Anzahl der besetzten Planstellen der Organisationseinheit an.

Bei Verwendung der ADOorg Komponente wird dieses Attribut automatisch befüllt.

- **Number of open positions (Org.- relative) (chapter "Indicators for organizational unit"):**

Calculated capacity related number of the vacant positions of the organizational unit.

 Ermittelte kapazitätsbezogene Anzahl der offenen Planstellen der Organisationseinheit.

- **Planned number of positions (Agg.- absolute) (chapter "Aggregated indicators"):**

Enter the planned number of the positions of the organizational unit including all subordinated organizational units.

Using the ADOorg component this attribute can be filled in automatically.

 Geben Sie die geplante Anzahl der Planstellen der Organisationseinheit inklusive aller untergeordneten Organisationseinheiten an.

Bei Verwendung der ADOorg Komponente wird dieses Attribut automatisch befüllt.

- **Number of occupied positions (Agg.- absolute) (chapter "Aggregated indicators"):**

Enter the number of the occupied positions of the organizational unit including all subordinated organizational units.

Using the ADOorg component this attribute can be filled in automatically.

 Geben Sie die Anzahl der besetzten Planstellen der Organisationseinheit inklusive aller untergeordneten Organisationseinheiten an.

Bei Verwendung der ADOorg Komponente wird dieses Attribut automatisch befüllt.

- **Number of open positions (Agg.- absolute) (chapter "Aggregated indicators"):**

Calculated number of the vacant positions of the organizational unit including all subordinated organisational units.

Ermittelte Anzahl der offenen Planstellen der Organisationseinheit inklusive aller untergeordneten Organisationseinheiten.

- **Planned number of positions (Agg.- relative) (chapter "Aggregated indicators"):**

Enter the planned capacity related number of the positions of the organizational unit including all subordinated organizational units.

Using the ADOorg component this attribute can be filled in automatically.

Geben Sie die geplante kapazitätsbezogene Anzahl der Planstellen der Organisationseinheit inklusive aller untergeordneten Organisationseinheiten an.

Bei Verwendung der ADOorg Komponente wird dieses Attribut automatisch befüllt.

- **Number of occupied positions (Agg.- relative) (chapter "Aggregated indicators"):**

Enter the capacity related number of the occupied positions of the organizational unit including all subordinated organizational units.

Using the ADOorg component this attribute can be filled in automatically.

Geben Sie die kapazitätsbezogene Anzahl der besetzten Planstellen der Organisationseinheit inklusive aller untergeordneten Organisationseinheiten an.

Bei Verwendung der ADOorg Komponente wird dieses Attribut automatisch befüllt.

- **Number of open positions (Agg.- relative) (chapter "Aggregated indicators"):**

Calculated capacity related number of the vacant positions of the organizational unit including all subordinated organizational units.

Ermittelte kapazitätsbezogene Anzahl der offenen Planstellen der Organisationseinheit inklusive aller untergeordneten Organisationseinheiten.

- **Bezeichnung (chapter "Deutsch"):**

Geben Sie eine Bezeichnung der Organisationseinheit ein. Dient der Dokumentation.

- **Beschreibung (chapter "Deutsch"):**

Geben Sie eine charakterisierende Beschreibung der Organisationseinheit an.

Dient der Dokumentation.

Describe the characteristics of the object.

The description will be used for documentation purposes.

- **Kommentar (chapter "Deutsch"):**

Geben Sie einen Kommentar zur Organisationseinheit an.
Dient der Dokumentation.

Enter any comments about the object.
The comments will be used for documentation purposes.

2.32 Class "Performer"

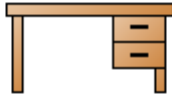

The objects of this class represent the individual performers in a working environment.
Every performer:

- can have one or more role(s),
- can belong to one or more organizational units,
- can be assigned to one or more cost centre,
- can be a manager of one or more organizational units and cost centres
- can use one or more resources.

Ein Objekt dieser Klasse repräsentiert einen einzelnen Bearbeiter innerhalb einer Arbeitsumgebung.
Jeder Bearbeiter kann:

- eine oder mehrere Rolle(n) haben
- zu einer oder mehrerer Organisationseinheit(en) gehören
- einer oder mehreren Kostenstellen zugerechnet werden
- eine oder mehrere Organisationseinheiten und Kostenstelle(n) leiten
- eine oder mehrere Ressourcen benutzen

The following attributes are defined for the class "Performer":

- **Name (chapter "Description"):**

- **Description (chapter "Description"):**

Describe the characteristics of the performer.

The description will be used for documentation purposes.

Part III

Geben Sie eine präzise Beschreibung des Bearbeiters ein.
Dient der Dokumentation.

- **Comment (chapter "Description"):**

Enter any comments about the performer.
The comments will be used for documentation purposes.

Geben Sie einen Kommentar zum Bearbeiter an.
Dient der Dokumentation.

- **Further education (chapter "Description"):**

Enter the title of the seminar (course) for further education of the employees in the column "Seminar title".

The column "Participated in" contains the time of the participation in the format MM.YYYY, i.e. month and year of participation in the seminar/course (e.g. 02.2002 for a course made in February 2002).

Geben Sie den Titel des Weiterbildungskurses in der Spalte "Seminartitel" an.
Die Spalte "Teilgenommen im" enthält Monat und Jahr der Teilnahme (im Format MM.JJJJ, z.B. 02.2002 für einen im Februar 2002 absolvierten Kurs).

- **Presence (chapter "Description"):**

The presence indicates how many days per week and how many hours per day the performer is present - i.e. available for work.

The entry of the values ('Days per week' and 'Hours per day') is set by selecting the appropriate presence profiles.

Note: If none of the available presence profiles are appropriate, please ask your ADONIS administrator to create the required profile.

Die Anwesenheit gibt an, wie viele Tage pro Woche und wie viele Stunden pro Tag der Bearbeiter anwesend ist.

Die Festlegung der Werte ("Tage pro Woche" und "Stunden pro Tag") erfolgt durch Auswahl des entsprechenden Anwesenheitsprofils.

Hinweis: Sollte keines der verfügbaren Profile Ihren Bedürfnissen entsprechen, wenden Sie sich an Ihren ADONIS-Administrator, um ein neues Profil erstellen zu lassen.

- **Hourly wages (chapter "Simulation data"):**

Enter the hourly wages of the performer.

Geben Sie den Stundenlohn des Bearbeiters ein.

- **Availability (chapter "Simulation data"):**

The value 'Availability' is referenced in the simulation algorithm 'Capacity analysis'.

The availability is automatically calculated based on the presence.

Formula: Days per week × Hours per day ÷ 40 × 100 (round number).

If necessary you can define the availability with an integer between 0 and 100.

Der Wert "Verfügbarkeit" dient der Simulation (Belastungsanalyse).

Die Verfügbarkeit wird standardmäßig in % angegeben und errechnet sich automatisch aus der Anwesenheit.

Formel: Tage pro Woche × Stunden pro Tag ÷ 40 × 100 (gerundet auf die nächste ganze Zahl).

Bei Bedarf können Sie die Verfügbarkeit auch durch Eingabe einer ganzen Zahl von 0 bis 100 definieren.

- **Calendar (chapter "Simulation data"):**

The value of the attribute 'Calendar' is evaluated in the simulation algorithm 'Workload analysis'.

It defines when a person is available for executing business processes respectively activities.

You can define the so-called 'day profiles' and assign them to the days of a year.

Der Wert des Attributs "Kalender" wird in der Simulation (Auslastungsanalyse) ausgewertet.

Mit ihm geben Sie an, wann der Akteur für die Bearbeitung von Geschäftsprozessen zur Verfügung steht.

Sie können sogenannte Tagesprofile ("Typen") definieren, die Sie den einzelnen Tagen eines Jahres zuordnen können.

- **Time dependent costs (chapter "Simulation data"):**

The 'time dependent costs' are evaluated in the process cost analysis.

Die "Zeitabhängigen Sachkosten" werden in der Simulation (Prozeßkostenanalyse) ausgewertet.

- **Personnel costs (chapter "Simulation results"):**

The personnel costs are the product of working time and hourly wage of the performer.

More information about the relevant period can be found in the attribute 'Info on results'.

Die Personalkosten sind das Produkt von Bearbeitungszeit und Stundenlohn des Bearbeiters.

Nähere Informationen zum Bezugszeitraum finden Sie im Attribut "Ergebnisinfo".

- **Capacity (chapter "Simulation results"):**

The capacity is the ratio of time a performer spent working on activities to the time he was actually present.

The performer cannot spend more time working on activities than he spends at work.

More information about the relevant period can be found in the attribute 'Info on results'.

Part III

Die Auslastung eines Bearbeiters ist das Verhältnis der zur Bearbeitung von Aktivitäten aufgewandten Zeit zur Anwesenheitszeit.

Der Bearbeiter kann dabei natürlich nicht mehr Zeit als er anwesend ist für die Verrichtung von Aufgaben aufwenden.

Nähere Informationen zum Bezugszeitraum finden Sie im Attribut "Ergebnisinfo".

- **Workload (chapter "Simulation results"):**

The workload is the ratio of the time one performer spent on working on activities compared to the time he has at his disposal in one year.

Because the workload analysis doesn't simulate on the time-axis, workloads of more than 100% can occur.

More information about the relevant period can be found in the attribute 'Info on results'.

Die Belastung eines Bearbeiters ist das Verhältnis der zur Bearbeitung von Aktivitäten aufgewandten Zeit zu der Zeit, die er im Jahr zur Verfügung steht.

Da die Belastungsanalyse nicht auf der Zeitachse simuliert, können Belastungen von mehr als 100% auftreten.

Nähere Informationen zum Bezugszeitraum finden Sie im Attribut "Ergebnisinfo".

- **Info on results (chapter "Simulation results"):**

The value of this attribute gives more information about the last evaluation carried out.

Dieses Attribut liefert nähere Informationen zur zuletzt durchgeführten Auswertung, deren Ergebnisse in das Modell übernommen wurden.

- **Bezeichnung (chapter "Deutsch"):**

Geben Sie eine Bezeichnung des Arbeiters ein. Dient der Dokumentation.

- **Beschreibung (chapter "Deutsch"):**

Geben Sie eine präzise Beschreibung des Bearbeiters ein.

Dient der Dokumentation.

Describe the characteristics of the object.

The description will be used for documentation purposes.

- **Kommentar (chapter "Deutsch"):**

Geben Sie einen Kommentar zum Bearbeiter an.

Dient der Dokumentation.

Enter any comments about the object.

The comments will be used for documentation purposes.

2.33 Class "Role"



The Role describes the task-range or job description of a performer.

- Every performer can have one or more roles.
- Several performers can have the same role.

Die "Rolle" beschreibt einen Aufgabenbereich des Bearbeiters.

- Jeder Bearbeiter kann eine oder mehrere Rollen haben
- Mehrere Bearbeiter können die gleiche Rolle haben

The following attributes are defined for the class "Role":

- **Name (chapter "Description"):**

- **Description (chapter "Description"):**

Describe the characteristics of the role.

The description will be used for documentation purposes.

Geben Sie eine detaillierte Beschreibung der Rolle an.

Dient der Dokumentation.

- **Comment (chapter "Description"):**

Enter any comments about the role.

The comments will be used for documentation purposes.

Geben Sie einen Kommentar zur Rolle an.

Dient der Dokumentation.

- **Referenced positions (chapter "Description"):**

Select the positions which are assigned to this role.

Part III

Bestimmen Sie die Planstellen, die dieser Rolle zugeordnet werden.

- **Referenced actor (chapter "Description"):**

It is possible to select an 'actor' from a use case diagram.

Bestimmen Sie einen "Akteur" aus einem Anwendungsfalldiagramm, der diese Rolle einnimmt.

- **Bezeichnung (chapter "Deutsch"):**

Geben Sie eine Bezeichnung der Rolle ein. Dient der Dokumentation.

- **Beschreibung (chapter "Deutsch"):**

Geben Sie eine detaillierte Beschreibung der Rolle an.

Dient der Dokumentation.

Describe the characteristics of the role.

The description will be used for documentation purposes.

- **Kommentar (chapter "Deutsch"):**

Geben Sie einen Kommentar zur Rolle an.

Dient der Dokumentation.

Enter any comments about the role.

The comments will be used for documentation purposes.

2.34 Class "Position"



A position is the individual assignment of a role to an organizational unit of the company.

- Every employee can be assigned to one or more positions.

- Several employees can be assigned to the same position.

Eine Planstelle ist die individuelle Zuordnung einer Rolle zu einer Organisationseinheit des Unternehmens.

- Jeder Mitarbeiter kann einer oder mehrerer Planstellen zugeordnet sein.
- Mehrere Mitarbeiter können der gleichen Planstelle zugeordnet sein.

The following attributes are defined for the class "Position":

- **Position name (chapter "Information about position"):**

Enter the name of the position.

Using the ADOorg component this attribute can be filled in automatically.

Geben Sie die Bezeichnung der Planstelle an.

Bei Verwendung der ADOorg Komponente wird dieses Attribut automatisch befüllt.

- **Position capacity (chapter "Information about position"):**

Enter the capacity of the position.

Using the ADOorg component this attribute can be filled in automatically.

Geben Sie die Kapazität der Planstelle an.

Bei Verwendung der ADOorg Komponente wird dieses Attribut automatisch befüllt.

- **Cost center (chapter "Information about position"):**

Enter the cost center of the position.

Using the ADOorg component this attribute can be filled in automatically.

Geben Sie die Kostenstelle der Planstelle an.

Bei Verwendung der ADOorg Komponente wird dieses Attribut automatisch befüllt.

- **Vacant (chapter "Information about position"):**

For vacant positions the attribute has to be set to 'yes'.

Using the ADOorg component this attribute can be set automatically.

Bei vakanten Planstellen muss diese Attribut auf 'ja' gesetzt werden.

Bei Verwendung der ADOorg Komponente wird dieses Attribut automatisch gesetzt.

- **Position holders (chapter "Personal information"):**

Enter the employees which are assigned to this position.

Using the ADOorg component this attribute can be filled in automatically.

Geben Sie die der Planstelle zugeordneten Mitarbeiter an.

Bei Verwendung der ADOorg Komponente wird dieses Attribut automatisch befüllt.

2.35 Class "Resource" (ADONIS BPMS WE Library 3.9)



Resources are taken into consideration in the algorithms 'Workload analysis' and 'Capacity Analysis'.

Ressourcen werden in der Simulation berücksichtigt (bei Belastungs- und Auslastungsanalyse).

The following attributes are defined for the class "Resource":

- **Name (chapter "Description"):**

- **Description (chapter "Description"):**

Describe the characteristics of the resource.

The description will be used for documentation purposes.

Geben Sie eine detaillierte Beschreibung der Ressource ein.

Dient der Dokumentation.

- **Comment (chapter "Description"):**

Enter any comments about the resource.

The comments will be used for documentation purposes.

Geben Sie einen Kommentar zur Ressource ein.

Dient der Dokumentation.

- **Type of resource (chapter "Description"):**

Select the type of the resource.

The graphical representation of the resource area will be adjusted accordingly.

Wählen Sie den Typ der Ressource aus.

Entsprechend erfolgt die Darstellung auf der Zeichenfläche.

- **Screenshot (chapter "Description"):**

Select an image file which will be shown as the resource symbol on the drawing area.

Wählen Sie eine Grafikdatei aus, die als Ressourcensymbol auf der Zeichenfläche visualisiert wird.

- **Hourly wages (chapter "Description"):**

Enter the hourly wages for using this resource.

Geben Sie den Stundensatz der Ressourcenbenützung an.

- **Bezeichnung (chapter "Deutsch"):**

Geben Sie eine Bezeichnung zur Ressource ein. Dient der Dokumentation.

- **Beschreibung (chapter "Deutsch"):**

Geben Sie eine detaillierte Beschreibung der Ressource ein.

Dient der Dokumentation.

Describe the characteristics of the resource.

The description will be used for documentation purposes.

- **Kommentar (chapter "Deutsch"):**

Geben Sie einen Kommentar zur Ressource ein.

Dient der Dokumentation.

Enter any comments about the resource.

The comments will be used for documentation purposes.

2.36 Class "Cost center"



The 'Cost center' will be evaluated in the process cost analysis.

Die "Kostenstelle" wird in der Simulation (Prozeßkostenanalyse) ausgewertet.

The following attributes are defined for the class "Cost center":

- **Name (chapter "Description"):**

- **Order (chapter "Description"):**

This attribute can be set with the help of the 'Object numbering' function, which numbers the objects of the business process model.

This can be useful for example within the component 'Documentation', to ensure that all objects are documented in the required order.

Dieses Attribut kann mit Hilfe der Numerierungsfunktion, mit der die Objekte des Arbeitsumgebungsmodells numeriert werden, belegt werden.

Die Reihenfolge wird beispielsweise bei Verwendung der Zusatzkomponente "Dokumentationskomponente" herangezogen, um die Objekte in gewünschter Abfolge zu dokumentieren.

- **Description (chapter "Description"):**

Describe the characteristics of the cost center.

The description will be used for documentation purposes.

Geben Sie eine detaillierte Beschreibung für die Kostenstelle ein.

Dient der Dokumentation.

- **Comment (chapter "Description"):**

Enter any comments about the cost center.

The comments will be used for documentation purposes.

Geben Sie einen Kommentar zur Kostenstelle ein.

Dient der Dokumentation.

- **Budget (chapter "Data for analysis"):**

Enter the budget of the Cost center.

The value in this field is used in the process cost analysis.

Geben Sie das Budget der Kostenstelle an.

Das Budget wird in der Simulation (Prozeßkostenanalyse) ausgewertet.

- **ON time (chapter "Data for analysis"):**

Enter the output neutral times.

The value in this field is used in the process cost analysis.

Geben Sie die leistungsmengenneutralen Zeiten an.

Wird in der Simulation (Prozeßkostenanalyse) ausgewertet.

- **ON fixed costs (chapter "Data for analysis"):**

Enter the output neutral fixed costs.

The value in this field is used in the process cost analysis.

Geben Sie die leistungsmengenneutralen Fixkosten an.

Wird in der Simulation (Prozeßkostenanalyse) ausgewertet.

- **ON processes (chapter "Data for analysis"):**

Enter the output neutral processes of the Cost center.

The value in this field is used in the process cost analysis.

Geben Sie die leistungsmengenneutralen Prozesse der Kostenstelle an.

Wird in der Simulation (Prozeßkostenanalyse) ausgewertet.

- **Bezeichnung (chapter "Deutsch"):**

Geben Sie eine Bezeichnung der Kostenstelle ein. Dient der Dokumentation.

- **Beschreibung (chapter "Deutsch"):**

Geben Sie eine detaillierte Beschreibung für die Kostenstelle ein.

Dient der Dokumentation.

Describe the characteristics of the cost center.

The description will be used for documentation purposes.

- **Kommentar (chapter "Deutsch"):**

Geben Sie einen Kommentar zur Kostenstelle ein.

Dient der Dokumentation.

Enter any comments about the cost center.

The comments will be used for documentation purposes.

2.37 Class "Aggregation" (ADONIS BPMS WE Library 3.9)



The aggregation supports the logical structure of model contents on the drawing area.

From an object that is placed on Aggregation, there is an automatic creation of connections between the Aggregation and the objects in the model with the relation 'Is inside'.

The relation 'Is inside' is not visualized!

Die Aggregation unterstützt die logische Strukturierung von Modellinhalten auf der Zeichenfläche.

Von einem Objekt auf einer Aggregation wird automatisch ein (nicht sichtbarer) Konnektor des Typs "ist innerhalb" zur Aggregation angelegt.

The following attributes are defined for the class "Aggregation":

- **Name (chapter "Description"):**

- **Display name (chapter "Description"):**

Select whether the name of the aggregation should be visualized on the drawing area.

Bestimmen Sie, ob der Name der Aggregation auf der Zeichenfläche aufscheinen soll.

- **Representation (chapter "Description"):**

Select whether the object name should be displayed inside or outside the object.

Bestimmen Sie, ob der Name der Aggregation außerhalb oder innerhalb des Rahmens dargestellt werden soll..

- **Font size (chapter "Description"):**

Select the font size for the text that is displayed on the drawing area.

Wählen Sie den Schriftgrad (die Schriftgröße) für die Darstellung des Texts aus.

- **Font style (chapter "Description"):**

Select the Font style for the text that is displayed on the drawing area.

Wählen Sie den Schriftstil für die Darstellung des angezeigten Texts aus.

- **Description (chapter "Description"):**

Describe the characteristics of the aggregation.

The description will be used for documentation purposes.

Geben Sie eine charakterisierende Beschreibung der Aggregation an.

Dient der Dokumentation.

- **Comment (chapter "Description"):**

Enter any comments about the aggregation.

The comments will be used for documentation purposes.

Geben Sie einen Kommentar zur Aggregation an.

Dient der Dokumentation.

- **Color (chapter "Object display"):**

You can define the object color as follows:

- Select a color in the 'Color' window which can be opened by clicking on the dialog button (on the right above the attribute field).

- Enter a color name (e.g. 'cornflowerblue'; a list of the color names can be found in the user documentation or in the online help).

- Enter an hexadecimal value (e.g.. '\$FFFFFF' for white), where the value begins with '\$' and contains the red, green and blue values with two digits for each.

Die Farbe des Objekts kann definiert werden durch:

- die Eingabe eines Farbnamens (z.B. "cornflowerblue"; eine Liste der Farbnamen finden Sie in der Benutzerdokumentation bzw. Online-Hilfe)

- die Eingabe eines Hexadezimalwerts (z.B. "\$FFFFFF" für white/weiß), wobei der Wert mit "\$" beginnt und daran anschließend - jeweils zweistellig - die Rot-, Grün-, und Blauwerte beinhaltet)

Part III

- die Auswahl einer Farbe über das Fenster "Farben", welches Sie durch Anklicken des Dialog-Buttons (rechts oberhalb des Attributfelds) öffnen.

- **Lines (chapter "Object display"):**

Select the type of representation for the framework.

Wählen Sie die Darstellungsart der Umrandungslinie aus.

- **Bezeichnung (chapter "Deutsch"):**

Optional. Geben Sie eine Bezeichnung der Aggregation ein.

- **Beschreibung (chapter "Deutsch"):**

Geben Sie eine charakterisierende Beschreibung der Aggregation an.

Dient der Dokumentation.

Describe the characteristics of the aggregation.

The description will be used for documentation purposes.

- **Kommentar (chapter "Deutsch"):**

Geben Sie einen Kommentar zur Aggregation an.

Dient der Dokumentation.

Enter any comments about the object.

The comments will be used for documentation purposes.

2.38 Class "Note" (ADONIS BPMS WE Library 3.9)



The 'Note' allows free text to be placed within a model.

Die "Notiz" erlaubt die Einbindung freier Texte in die grafische Modellbeschreibung.

The following attributes are defined for the class "Note":

- **Text (chapter "Description"):**

Enter the text for the note.

Geben Sie hier den Text der Notiz ein.

- **Font size (chapter "Description"):**

Select the font size for the text that is displayed on the drawing area.

Wählen Sie den Schriftgrad (die Schriftgröße) für die Darstellung des Texts aus.

- **Font style (chapter "Description"):**

Select the font style for the text that is displayed on the drawing area.

Wählen Sie den Schriftstil für die Darstellung des angezeigten Texts aus.

- **Color (chapter "Description"):**

You can define the object color as follows:

- Select a color in the 'Color' window which can be opened by clicking on the dialog button (on the right above the attribute field).

- Enter a color name (e.g. 'cornflowerblue'; a list of the color names can be found in the user documentation or in the online help).

- Enter an hexadecimal value (e.g. '\$FFFFFF' for white), where the value begins with '\$' and contains the red, green and blue values with two digits for each.

Die Farbe des Objekts kann definiert werden durch:

- die Auswahl einer Farbe über das Fenster "Farben", welches Sie durch Anklicken des Dialog-Buttons (rechts oberhalb des Attributfelds) öffnen

- die Eingabe eines Farbnamens (z.B. "cornflowerblue"; eine Liste finden Sie in Benutzerdokumentation und Online-Hilfe)

- die Eingabe eines Hexadezimalwerts (z.B. "\$FFFFFF" für white/weiß), wobei der Wert mit '\$' beginnt und daran anschließend - jeweils zweistellig - die Rot-, Grün-, und Blauwerte beinhaltet

- **External graphic (chapter "Description"):**

Reference a graphic file.

The following file formats are available:

- "bmp"

- "gif"

- "ico"

- "jpeg"

Part III

- "png"
- "targa"
- "tiff"
- "wbmp"
- "xpm"

Enter a path and file name in the field "Program arguments". If you want to open the referenced file with the program different than system default, select the program in the field "Executable".

Referenzieren Sie eine Grafikdatei, die eingebunden werden soll.

Folgende Grafikformate werden unterstützt:

- "bmp"
- "gif"
- "ico"
- "jpeg"
- "png"
- "targa"
- "tiff"
- "wbmp"
- "xpm"

Falls diese Datei mit einem bestimmten Tool geöffnet werden soll, geben Sie dieses in der Auswahl an. Andernfalls "<automatisch>" wird die Standardeinstellung gewählt.

Im Feld "Parameter" geben Sie bitte Pfad und Dateinamen der Grafik an.

- **Calculate size of graphic automatically (chapter "Description"):**

Die Aktivierung dieser Option ermöglicht die exakte Berechnung der von jeder extern eingebundenen Grafik auf dem Zeichenbereich benötigten Fläche.

Es wird empfohlen, die automatische Berechnung der Grafikgröße vor dem Einbinden der Grafik zu aktivieren.

Ist sie aktiv, wird die Größe der Grafik auf der Zeichenfläche anhand der Größe der Quelldatei errechnet und das Verhältnis zwischen Breite und Höhe bleibt konstant.

Ist sie hingegen deaktiviert, kann die Größe der Grafik manuell gesetzt (und auch das Verhältnis zwischen Breite und Höhe nachträglich geändert) werden.

This attribute allows it to calculate the exact area a referenced graphic needs.

It is recommended to activate the automatic calculation before referencing an external graphic.

Is this function activated, the size of the object "Note" is automatically adjusted to the objects' size. When changing the size the aspect ratio will be kept.

Is this function deactivated, the graphic will be inserted minimized. The graphic must be adjusted manually without keeping the aspect ratio.

- **Notiz (chapter "Deutsch"):**

Geben Sie die Notiz ein.

Enter the text for the note.

2.39 Class "Swimlane (horizontal)" (ADONIS BPMS WE Library 3.9)



"Swimlanes" are areas of responsibilities (e.g. workgroups, units etc.).

In a process executed in different areas of responsibilities, each area becomes a swimlane on its own where each object can be placed according to its area.

In each swimlane the responsible role, performer or organizational unit from the working environment can be referenced.

 "Schwimmbahnen" (engl. "swimlane") sind Verantwortlichkeitsbereiche (z.B. Arbeitsgruppen, Abteilungen etc.).

Läuft ein Prozeß in mehreren dieser Bereiche ab, so wird jeder Verantwortungsbereich in einer eigenen Schwimmbahn zusammengefasst und die entsprechenden Objekte des Geschäftsprozesses in dieser platziert.

In jeder Schwimmbahn kann die verantwortliche Rolle, der verantwortliche Bearbeiter oder die verantwortliche Organisationseinheit aus einem Arbeitsumgebungsmodell referenziert werden.

The following attributes are defined for the class "Swimlane (horizontal)":

- **Name (chapter "Description"):**

- **Description (chapter "Description"):**

Enter a description for the swimlane.

For documentation purposes.

 Geben Sie eine Beschreibung zur Schwimmbahn an.

Dient der Dokumentation.

- **Comment (chapter "Description"):**

Enter any comments about the swimlane.

The comments will be used for documentation purposes.

Geben Sie einen Kommentar zur Schwimmbahn an.

Dient der Dokumentation.

- **Open questions (chapter "Description"):**

Here you can enter any questions that are still open for this swimlane.

Hinterlegen Sie hier eventuell noch vorhandene offene Fragen zu dieser Schwimmbahn.

- **Color (chapter "Representation"):**

You can define the object color as follows:

- Select a color in the 'Color' window which can be opened by clicking on the dialog button (on the right above the attribute field).

- Enter a color name (e.g. 'cornflowerblue'; a list of the color names can be found in the user documentation or in the online help).

- Enter an hexadecimal value (e.g. '\$FFFFFF' for white), where the value begins with '\$' and contains the red, green and blue values with two digits for each.

Die Farbe des Objekts kann definiert werden durch:

- die Auswahl einer Farbe über das Fenster "Farben", welches Sie durch Anklicken des Dialog-Buttons (rechts oberhalb des Attributfelds) öffnen

- die Eingabe eines Farbnamens (z.B. "cornflowerblue"; eine Liste finden Sie in Benutzerdokumentation und Online-Hilfe)

- die Eingabe eines Hexadezimalwerts (z.B. "\$FFFFFF" für white/weiß), wobei der Wert mit '\$' beginnt und daran anschließend - jeweils zweistellig - die Rot-, Grün-, und Blauwerte beinhaltet

- **Display water marks (chapter "Representation"):**

Please select, if the name of the swimlane should be visualized as a watermark. Using the watermark, the swimlane name will be repeated in the swimlane background periodically. The watermark helps reading large models.

Selektieren Sie, ob sie die Schwimmbahnbeschriftung auch als Wasserzeichen einblenden wollen. Mit Hilfe des Wasserzeichens wird die Schwimmbahnbeschriftung in periodischen Abständen im Schwimmbahn hintergrund dargestellt. Das Wasserzeichen hilft beim Lesen großer Modelle.

- **Alignment (chapter "Representation"):**

The alignment defines whether the name of the swimlane and the watermark will be visualized on top, centered or on the bottom of the swimlane.

Durch die Ausrichtung können Sie die Schwimmbahnbeschriftung und das Wasserzeichen am oberen Rand, zentriert oder am unteren Rand der Schwimmbahn anzeigen.

- **Bezeichnung (chapter "Deutsch"):**

Enter a name.

For documentation purposes.

- **Beschreibung (chapter "Deutsch"):**

Geben Sie eine charakterisierende Beschreibung zur Schwimmbahn ein.

Dient der Dokumentation.

Describe the characteristics of the swimlane.

The description will be used for documentation purposes.

- **Kommentar (chapter "Deutsch"):**

Geben Sie einen Kommentar zur Schwimmbahn ein.

Dient der Dokumentation.

Enter any comments about the swimlane.

The comments will be used for documentation purposes.

2.40 Class "Swimlane (vertical)" (ADONIS BPMS WE Library 3.9)

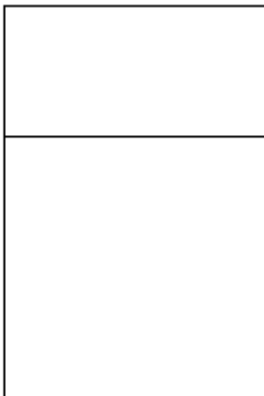

"Swimlanes" are areas of responsibilities (e.g. workgroups, units etc.).

Is a process executed in different areas of responsibilities, each area becomes a swimlane on its own where each object can be placed according to its area.

In each swimlane the responsible role, performer or organizational unit from the working environment can be referenced.

"Schwimmbahnen" (engl. "swimlane") sind Verantwortlichkeitsbereiche (z.B. Arbeitsgruppen, Abteilungen etc.).

Läuft ein Prozeß in mehreren dieser Bereiche ab, so wird jeder Verantwortungsbereich in einer eigenen Schwimmbahn zusammengefasst und die entsprechenden Objekte des Geschäftsprozesses in dieser platziert.

In jeder Schwimmbahn kann die verantwortliche Rolle, der verantwortliche Bearbeiter oder die verantwortliche Organisationseinheit aus einem Arbeitsumgebungsmodell referenziert werden.

The following attributes are defined for the class "Swimlane (vertical)":

- **Name (chapter "Description"):**

- **Description (chapter "Description"):**

Describe the characteristics of the swimlane.

The description will be used for documentation purposes.

Geben Sie eine Beschreibung zur Schwimmbahn an.

Dient der Dokumentation.

- **Comment (chapter "Description"):**

Enter any comments about the swimlane.

The comments will be used for documentation purposes.

Geben Sie einen Kommentar zur Schwimmbahn an.

Dient der Dokumentation.

- **Open questions (chapter "Description"):**

Here you can enter any open questions which are still to be answered for the swimlane.

Hinterlegen Sie hier eventuell noch vorhandene offene Fragen zu dieser Schwimmbahn.

- **Color (chapter "Representation"):**

You can define the object color as follows:

- Select a color in the 'Color' window which can be opened by clicking on the dialog button (on the right above the attribute field).

- Enter a color name (e.g. 'cornflowerblue'; a list of the color names can be found in the user documentation or in the online help).

- Enter an hexadecimal value (e.g. '\$FFFFFF' for white), where the value begins with '\$' and contains the red, green and blue values with two digits for each.

Die Farbe des Objekts kann definiert werden durch:

- die Auswahl einer Farbe über das Fenster "Farben", welches Sie durch Anklicken des Dialog-Buttons (rechts oberhalb des Attributfelds) öffnen

- die Eingabe eines Farbnamens (z.B. "cornflowerblue"; eine Liste finden Sie in Benutzerdokumentation und Online-Hilfe)

- die Eingabe eines Hexadezimalwerts (z.B. "\$FFFFFF" für white/weiß), wobei der Wert mit '\$' beginnt und daran anschließend - jeweils zweistellig - die Rot-, Grün-, und Blauwerte beinhaltet

- **Display water marks (chapter "Representation"):**

Select if the name of the swimlane should be visualized as a watermark. Using the watermark, the swimlane name will be repeated in the swimlane background periodically. The watermark helps reading large models.

Selektieren Sie, ob sie die Schwimmbahnbeschriftung auch als Wasserzeichen einblenden wollen. Mit Hilfe des Wasserzeichens wird die Schwimmbahnbeschriftung in periodischen Abständen im Schwimmbahnhintergrund dargestellt. Das Wasserzeichen hilft beim Lesen großer Modelle.

- **Alignment (chapter "Representation"):**

The alignment defines whether the name of the swimlane and the watermark will be visualized on top, centered or on the bottom of the swimlane.

Durch die Ausrichtung können Sie die Schwimmbahnbeschriftung und das Wasserzeichen am oberen Rand, zentriert oder am unteren Rand der Schwimmbahn anzeigen.

- **Bezeichnung (chapter "Deutsch"):**

Enter a name.

For documentation purposes.

- **Beschreibung (chapter "Deutsch"):**

Geben Sie eine charakterisierende Beschreibung zur Schwimmbahn ein.

Dient der Dokumentation.

Describe the characteristics of the swimlane.

The description will be used for documentation purposes.

- **Kommentar (chapter "Deutsch"):**

Geben Sie einen Kommentar zur Schwimmbahn ein.

Dient der Dokumentation.

Enter any comments about the swimlane.

The comments will be used for documentation purposes.

3. Relation classes

In the following chapters you will find a description of all relation classes available for modelling. The current availability depends on the selected **model type** (see chap. 1., p. 16) on the one hand and on the selected view mode on the other hand.

Hint: A description of the **view modes** you will find in the previous chapters for the particular model types.

3.1 Relation class "Subsequent"



The relation 'Subsequent' defines the flow of activities and decisions in a Business Process. It can be used to link all types of objects with the exception of 'Variable', 'Random generator', 'Resource', 'Aggregation', 'Performance indicator' and 'Performance indicator overview'. The 'Subsequent' relation may contain a transition condition when it follows a Decision or Parallelity.

The following attributes are defined for the relation class "Subsequent":

- **Denomination (chapter "Description"):**
Enter a characterizing denomination. For documentation purposes.
- **Description (chapter "Description"):**
Enter a description. Serves for documentation purposes.
- **Comment (chapter "Description"):**
Enter any comments about the relation.
The comments will be used for documentation purposes.
- **Visualized values (chapter "Description"):**
Choose one of the following values to display the attributes described beneath in the graphical model representation.
Each single value will be shown below or to the right from the edge of the middle point (green diamond), depending on the value specified by the attribute 'Representation'.
(a) 'denomination'
The value of the attribute "Bezeichnung" will be displayed beneath or right from the edge middle point.

(b) "transition condition"

The value of the attribute "transition condition" will be displayed beneath or right from the edge middle point.

(c) "transition probability"

The value of the attribute "transition probability" will be displayed beneath or right from the edge middle point.

(d) "transition probability and transition condition"

The value of the attribute "transition probability" will be displayed beneath or right, the value of the attribute "transition condition" will be displayed above or left from the edge middle point.

(e) "transition probability and denomination"

The value of the attribute "denomination" will be displayed beneath or right, the value of the attribute "transition probability" will be displayed above or left from the edge middle point.

(f) "transition condition and denomination"

The value of the attribute "denomination" will be displayed beneath or right, the value of the attribute "transition condition" will be displayed above or left from the edge middle point.

 Wählen Sie einen der folgenden Werte aus, um die untenstehend beschriebenen Attribute in der Modellgrafik anzuzeigen.

Die Anzeige eines einzelnen Wertes erfolgt - in Abhängigkeit vom gewählten Wert des Attributs 'Darstellung' - unterhalb des Kantenmittelpunktes bzw. rechts vom Kantenmittelpunkt (grüne Raute).

(a) "Bezeichnung"

Der Wert des Attributs 'Bezeichnung' wird unterhalb oder rechts angezeigt.

(b) "Übergangsbedingung"

Der Wert des Attributs 'Übergangsbedingung' wird unterhalb oder rechts angezeigt.

(c) "Übergangswahrscheinlichkeit"

Der Wert des Attributs 'Übergangswahrscheinlichkeit' wird unterhalb oder rechts angezeigt.

(d) "Übergangswahrscheinlichkeit und Übergangsbedingung"

Der Wert des Attributs 'Übergangsbedingung' wird unterhalb oder rechts, der Wert des Attributs 'Übergangswahrscheinlichkeit' wird oberhalb oder links angezeigt.

(e) "Übergangswahrscheinlichkeit und Bezeichnung"

Der Wert des Attributs 'Bezeichnung' wird unterhalb oder rechts, der Wert des Attributs 'Übergangswahrscheinlichkeit' wird oberhalb oder links angezeigt.

(f) "Übergangsbedingung und Bezeichnung"

Der Wert des Attributs 'Bezeichnung' wird unterhalb oder rechts, der Wert des Attributs 'Übergangsbedingung' wird oberhalb oder links angezeigt.

● **Representation (chapter "Description"):**

Define if the attribute values specified by the attribute 'visualized values' are displayed left (and right) from the edge middle point or beneath (and above) the edge middle point in the graphical representation.

 Geben Sie an, ob die im Attribut 'Visualisierte Werte' ausgewählten Attributwerte rechts (und links) vom Kantenmittelpunkt oder unterhalb (und oberhalb) des Kantenmittelpunktes in der Modellgrafik angezeigt werden sollen.

● **Font colour (chapter "Description"):**

Choose a colour for the visualisation of the attribute values specified by the attribute 'visualized values'.

Wählen Sie die Farbe zur Anzeige der im Attribut 'Visualisierte Werte' ausgewählten Attributwerte aus.

● **Transition condition (chapter "Details"):**

A transition condition consists either of one elementary expression or several elementary expressions which are linked together by OR, AND or NOT. The linking is succeeded with the expression NOT, OR or AND.

Examples:

- (a) (<elementary expression1>) AND (<elementary expression2>)
- (b) (<elementary expression1>) AND (<elementary expression2>)
- (c) NOT (<elementary expression1>)
- (d) (<elementary expression1>) AND (NOT (<elementary expression2>))

An elementary expression is defined as:

<Variable name><Operator><Constant> where

- <Variable name> - the name of an instantiated variable,
- <Operator> - may be <, > or =
- <Constant> - a numeric or alphanumeric expression (a numeric expression may only consist of integers; an alphanumeric expression must be delimited by single quotes).

For example:

- (a) X='Yes' - this condition is fulfilled if the variable X has the value 'Yes' (X is assigned values through a discrete distribution!)
- (b) (X='Yes') AND (Y='Yes'), this condition is fulfilled where variables X and Y have the value 'Yes' (X and Y are discrete distributed!)
- (c) Z<1000, this condition is fulfilled if Z is less than 1000 (Z is continually distributed!)
- (d) NOT(Z<1000), this condition is fulfilled if Z greater or equal 1000 is (complementary to Z<1000, Z is continually distributed!)
- (e) (X='NO') OR (NOT (Z=1000)), this condition is fulfilled if either X has the value 'NO' or Z is not equal to 1000 (X is discrete, Z is continually distributed!)

● **Transition probability (chapter "Details"):**

For simulation and assessment (modelling), alternative paths (these are paths starting from decisions) have to be set with transition conditions.

The transition condition consists of:

- A) one or more connected elementary expressions
- B) a probability or
- C) a macro definition

A) elementary expressions:

An elementary expression is defined as <Variable name><Operator><Constant>.

Use the support dialogue for defining an correct expression.

The connection can be created by using the expressions NOT, OR or AND.

B) Probabilities:

Transition probabilities are represented by floating point numbers > 0 and < 1 (e.g. 0.7)

HINT:

The sum of the values in the attribute 'transition condition' of all alternative paths starting from decisions has to be 1.

NOTE:

The value of the attribute 'transition condition' is used only for simulation and evaluation purposes. For analytic evaluation (analysis component) you have to enter probabilities for alternative paths in the attribute 'transition probability'.

C) Macro definitions:

Macros are supporting you when using complex and/or frequently repeating transition values and are defined in the transition conditions of the subsequent relation.

The definition of a macro is made by entering a colon and then the name of the macro.

ATTENTION:

The macro name must not start with numbers from 0 to 9, the symbols + - : = < > * / () . , ' and blanks or return. Also the macro name must not contain the symbols + - : = < > * / () . , ' and blanks or return.

Für die Simulation sowie die Bewertung (Modellierung) müssen alternative Pfade (d.s. jene Pfade, welche von einer Entscheidung ausgehen) mit Übergangsbedingungen belegt werden.

Die Übergangsbedingung besteht aus:

- A) einem elementaren Ausdruck (bzw. mehreren verknüpften elementaren Ausdrücken),
- B) einer Wahrscheinlichkeit oder
- C) einer Makro-Definition.

A) Elementare Ausdrücke:

Ein elementarer Ausdruck ist definiert als <Variablenname><Operator><Konstante>.

Zur Definition eines korrekten Ausdrucks verwenden Sie die Eingabeunterstützung.

Die Verknüpfung erfolgt mit den Ausdrücken NICHT, ODER oder UND.

B) Wahrscheinlichkeiten:

Übergangswahrscheinlichkeiten werden durch eine Fließkommazahl > 0 und < 1 ausgedrückt (z.B. 0.7).

HINWEIS:

Die Summe der Wahrscheinlichkeiten im Attribut 'Übergangsbedingung' aller alternativen Pfade nach einer Entscheidung muß genau 1 ergeben.

ACHTUNG:

Der Wert im Attribut 'Übergangsbedingung' wird ausschließlich für die Simulation und die Bewertung verwendet.

Für die Rechnerische Auswertung (Analysekomponente) müssen Sie Wahrscheinlichkeiten für alternative Pfade im Attribut 'Übergangswahrscheinlichkeit' eintragen.

C) Makro-Definitionen:

Makros unterstützen Sie bei komplexen und/oder häufig wiederkehrenden Übergangswerten und werden in den Übergangsbedingungen der Nachfolger-Beziehungen definiert.

Die Definition eines Makros erfolgt, indem Sie anschließend an die jeweilige Übergangsbedingung einen Doppelpunkt und darauf folgend den Makronamen angeben.

ACHTUNG:

Der Makroname darf nicht mit Ziffern von 0 bis 9, den Zeichen + - : = < > * / () . , ' sowie Leerzeichen (Blank) oder Zeilenschaltung (Return) beginnen. Weiters sind die Zeichen + - : = < > * / () . , ' sowie Leerzeichen (Blank) oder Zeilenschaltung (Return) im Makronamen nicht zulässig.

- **Info zur Übergangsbedingung (chapter "Deutsch"):**

Geben Sie Info zur Übergangsbedingung ein. Dient der Dokumentation.

- **Bezeichnung (chapter "Deutsch"):**

Geben Sie einen Namen ein. Dient der Dokumentation.

- **Beschreibung (chapter "Deutsch"):**

Geben Sie eine Beschreibung ein. Dient der Dokumentation.

- **Kommentar (chapter "Deutsch"):**

Geben Sie einen Kommentar ein. Dient der Dokumentation.

3.2 Relation class "Sets variable"

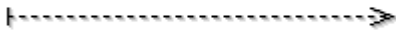

The relation "Sets variable" connects 1 object of the class "Random generator" with 1 object of the class "Variable". The relation is used from the random generator to the variable.

Hint: There are no attributes defined for the relation class "Sets variable".

3.3 Relation class "Sets"

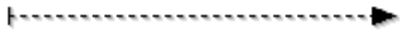

The relation "Sets" connects 1 object of the class "Random generator" with one object of "Process start", "Subprocess", "Activity", "Decision", "Parallelity" oder "Merging". The relation is used from random generator to the target.

Hint: There are no attributes defined for the relation class "Sets".

3.4 Relation class "Uses"



The relation "Uses" connects 1 object of the class "Activity" with 1 object of the class "Resource". The relation is used from the activity to the resource.

Hint: There are no attributes defined for the relation class "Uses".

3.5 Relation class "communicates"

The relation "communicates" connects "actors" with "use cases". It states that actors are involved in some form in the use cases to which a connection exists through a relation "communicates". -----
----- Die Beziehung "kommuniziert" verbindet 2 Objekte der Klassen "Akteur" und "Anwendungsfall" in beliebiger Kombination miteinander. Sie besagt, daß zwischen diesen Akteuren und Anwendungsfällen irgendeine Interaktion stattfindet.

The following attributes are defined for the relation class "communicates":

- **Name (chapter "Description"):**
- **Description (chapter "Description"):**
Describe the characteristics of the object.
The description will be used for documentation purposes.

Geben Sie eine charakterisierende Beschreibung zur "kommuniziert"-Beziehung ein.
Dient der Dokumentation.
- **Comment (chapter "Description"):**
Enter any comments about the object.
The comments will be used for documentation purposes.

Geben Sie einen Kommentar zur "kommuniziert"-Beziehung ein.
Optional. Dient der Dokumentation.
- **Bezeichnung (chapter "Deutsch"):**
Geben sie eine Bezeichnung ein. Dient der Dokumentation.
- **Beschreibung (chapter "Deutsch"):**
Geben Sie eine charakterisierende Beschreibung zur "kommuniziert"-Beziehung ein.
Dient der Dokumentation.

Describe the characteristics of the object.
The description will be used for documentation purposes.

- **Kommentar (chapter "Deutsch"):**

Geben Sie einen Kommentar zur "kommuniziert"-Beziehung ein.

Optional. Dient der Dokumentation.

Enter any comments about the object.

The comments will be used for documentation purposes.

3.6 Relation class "Value flow"



The value flow describes the value exchange between business processes. You can select either information flow, material flow or control flow. -----

----- Der Leistungsfluß beschreibt den Leistungsaustausch zwischen Geschäftsprozessen. Es wird Informations-, Material- und Kontrollfluß unterschieden.

The following attributes are defined for the relation class "Value flow":

- **Type (chapter "Description"):**

Select the value flow type. You can select either information flow, material flow or control flow.

Bitte wählen Sie den Typ des Leistungsflusses. Es wird zwischen Informations-, Material- und Kontrollfluß unterschieden.

3.7 Relation class "Generalisation"



The relation "Generalisation" connects two objects of the class "use case" hierarchically. It displays that one "use case" is a special case of another "use case". The special case contains besides all characteristics of the general use cases. The relation is used from the special "use case" to the general "use case".

----- Die Beziehung "Generalisierung" verbindet zwei Objekte der Klasse "Anwendungsfall" hierarchisch. Sie zeigt an, daß ein Anwendungsfall ein Spezialfall eines anderen, allgemeineren Anwendungsfalls ist. Der Spezialfall beinhaltet alle Eigenschaften des allgemeinen Anwendungsfalls. Der Konnektor wird dabei vom Spezialfall zum allgemeinen Anwendungsfall gezogen. Die Beziehung "erweitert" wird also verwendet, wenn man eine Abweichung vom Normalfall als Ganzes beschreiben und ausführen möchte.

The following attributes are defined for the relation class "Generalisation":

- **Name (chapter "Description"):**

- **Description (chapter "Description"):**

Describe the characteristics of the object.

The description will be used for documentation purposes.

Geben Sie eine charakterisierende Beschreibung zur "Generalisierung"-Beziehung ein.

Dient der Dokumentation.

- **Comment (chapter "Description"):**

Enter any comments about the relation.

The comments will be used for documentation purposes.

Geben Sie einen Kommentar zur "Generalisierung"-Beziehung ein.

Optional. Dient der Dokumentation.

- **Bezeichnung (chapter "Deutsch"):**

Geben sie eine Bezeichnung ein. Dient der Dokumentation.

- **Beschreibung (chapter "Deutsch"):**

Geben Sie eine charakterisierende Beschreibung zur "Generalisierung"-Beziehung ein.

Dient der Dokumentation.

Describe the characteristics of the relation.

The description will be used for documentation purposes.

- **Kommentar (chapter "Deutsch"):**

Geben Sie einen Kommentar zur "Generalisierung"-Beziehung ein.

Optional. Dient der Dokumentation.

Enter any comments about the relation.

The comments will be used for documentation purposes.

3.8 Relation class "contains"

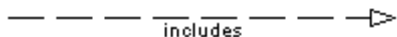

The relation "contains" connects two objects of the class "use case" hierarchically. It indicates that the execution of one "use case" will implicitly trigger the execution of another "use case". This relation is used to represent separately these parts of a diagram which appear often and are referenced from another "use case". The relation is used from the object which is super ordered to the referenced one.

Die Beziehung "beinhaltet" verbindet 2 Objekte der Klasse "Anwendungsfall" hierarchisch. Sie zeigt an, daß die Ausführung eines Anwendungsfalls die Ausführung eines anderen Anwendungsfalls beinhaltet. Sie wird verwendet, um häufig auftretende Teile separat darzustellen und von anderen Anwendungsfällen zu referenzieren. Dieser beinhaltet Anwendungsfall ist dabei aber immer nur Teil eines Ganzen (vgl. "benutzt"). Der Konnektor wird immer vom übergeordneten zum aufgerufenen Fall gezogen.

The following attributes are defined for the relation class "contains":

- **Name (chapter "Description"):**

- **Description (chapter "Description"):**

Describe the characteristics of the relation.

The description will be used for documentation purposes.

Geben Sie eine charakterisierende Beschreibung zur "beinhaltet"-Beziehung ein.

Dient der Dokumentation.

- **Comment (chapter "Description"):**

Enter any comments about the object.

The comments will be used for documentation purposes.

Geben Sie einen Kommentar zur "beinhaltet"-Beziehung ein.

Optional. Dient der Dokumentation.

- **Bezeichnung (chapter "Deutsch"):**

Geben sie eine Bezeichnung ein. Dient der Dokumentation

- **Beschreibung (chapter "Deutsch"):**

Geben Sie eine charakterisierende Beschreibung zur "beinhaltet"-Beziehung ein.

Dient der Dokumentation.

Describe the characteristics of the relation.

The description will be used for documentation purposes.

- **Kommentar (chapter "Deutsch"):**

Geben Sie einen Kommentar zur "beinhaltet"-Beziehung ein.

Optional. Dient der Dokumentation.

Enter any comments about the relation.

The comments will be used for documentation purposes.

3.9 Relation class "extends"

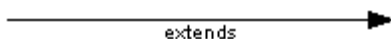

The relation "extends" connects two objects of the class "use case" hierarchically. One case is a "normal case" and the second one (extension) appears only under certain conditions. The relation is used from the extending "use case" to the "normal case".

Die Beziehung "erweitert" verbindet 2 Objekte der Klasse "Anwendungsfall" hierarchisch. Dabei ist ein Anwendungsfall der "Normalfall" und der zweite (die Erweiterung) ein Zusatz, der nur unter bestimmten Bedingungen auftritt. Der Konnektor wird dabei vom erweiternden "Anwendungsfall" zum "Normalfall" gezogen. Die Beziehung "erweitert" wird verwendet, wenn man eine Variante des Normalverhaltens beschreiben und präzise Reglementierungen aufstellen möchte.

The following attributes are defined for the relation class "extends":

- **Name (chapter "Description"):**

- **Description (chapter "Description"):**

Describe the characteristics of the relation.

The description will be used for documentation purposes.

Geben Sie eine charakterisierende Beschreibung zur "erweitert"-Beziehung ein.

Dient der Dokumentation.

- **Comment (chapter "Description"):**

Enter any comments about the relation.

The comments will be used for documentation purposes.

Geben Sie einen Kommentar zur "erweitert"-Beziehung ein.

Optional. Dient der Dokumentation.

- **Bezeichnung (chapter "Deutsch"):**

Geben Sie eine Bezeichnung ein. Dient der Dokumentation.

- **Beschreibung (chapter "Deutsch"):**

Geben Sie eine charakterisierende Beschreibung zur "erweitert"-Beziehung ein.

Dient der Dokumentation.

Describe the characteristics of the relation.

The description will be used for documentation purposes.

- **Kommentar (chapter "Deutsch"):**

Geben Sie einen Kommentar zur "erweitert"-Beziehung ein.

Optional. Dient der Dokumentation.

Enter any comments about the relation.

The comments will be used for documentation purposes.

3.10 Relation class "uses"

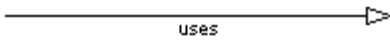

The relation "uses" connects 1 object of the class "Activity" with 1 object of the class "Resource". The relation is used from the activity to the resource.

The following attributes are defined for the relation class "uses":

- **Name (chapter "Description"):**

- **Description (chapter "Description"):**

Describe the characteristics of the relation.

The description will be used for documentation purposes.

Geben Sie eine charakterisierende Beschreibung zur "benutzt"-Beziehung ein.

Dient der Dokumentation.

- **Comment (chapter "Description"):**

Enter any comments about the relation.

The comments will be used for documentation purposes.

Geben Sie einen Kommentar zur "benutzt"-Beziehung ein.

Optional. Dient der Dokumentation.

- **Bezeichnung (chapter "Deutsch"):**

Geben Sie eine Bezeichnung ein.

Dient der Dokumentation.

- **Beschreibung (chapter "Deutsch"):**

Geben Sie eine charakterisierende Beschreibung zur "benutzt"-Beziehung ein.

Dient der Dokumentation.

Describe the characteristics of the relation.

The description will be used for documentation purposes.

- **Kommentar (chapter "Deutsch"):**

Geben Sie einen Kommentar zur "benutzt"-Beziehung ein.

Optional. Dient der Dokumentation.

 Enter any comments about the relation.

The comments will be used for documentation purposes.

3.11 Relation class "Has process"



The relation "Has process" connects two objects of the class "Process" hierarchically. The relation is used from the object which is super ordered to the lower ordered one. -----

----- Die Beziehung "hat Prozeß" verbindet 2 Objekte der Klasse "Prozeß" hierarchisch. Der Konnektor wird dabei immer vom übergeordneten zum Subprozeß gezogen.

The following attributes are defined for the relation class "Has process":

- **Name (chapter "Description"):**

Geben Sie eine charakterisierende Bezeichnung des Nachfolgers an.

Dient der Dokumentation.

- **Representation (chapter "Description"):**

Select if the attribute values specified by the attribute 'visualized values' are displayed left (and right) from the edge middle point or beneath (and above) the edge middle point in the graphical representation.

 Geben Sie an, ob die im Attribut 'Visualisierte Werte' ausgewählten Attributwerte rechts (und links) vom Kantenmittelpunkt oder unterhalb (und oberhalb) des Kantenmittelpunkts in der Modellgrafik angezeigt werden sollen.

- **Fontcolor (chapter "Description"):**

Choose a colour for the visualisation of the attribute values specified by the attribute 'visualized values'.

 Wählen Sie die Farbe zur Anzeige der im Attribut 'Visualisierte Werte' ausgewählten Attributwerte aus.

- **Bezeichnung (chapter "Deutsch"):**

Enter a name.

For documentation purposes.

3.12 Relation class "has Subdocument"



The relation "has Subdocument" connects two objects of the class "Document" hierarchically. It is used from an upper graded Document to a subordinated Document. -----
----- Die Beziehung "hat Subdokument" verbindet zwei Objekte der Klasse "Dokument" hierarchisch. Die Verbindung wird vom übergeordneten Dokument zum untergeordneten Dokument gezogen.

Hint: There are no attributes defined for the relation class "has Subdocument".

3.13 Relation class "has "

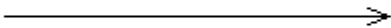

This relation represents dependencies between elements of a product model. The element with the outgoing connector owns the other element. This relation is valid for products as well as product components. -----
-- Über diese Beziehungen werden Abhängigkeiten zwischen den Elementen eines Produktmodells beschrieben. Das Element, von dem der Pfeil wegführt, besitzt das andere Element. Diese Beziehung gilt sowohl für Produkte als auch Produktkomponenten.

The following attributes are defined for the relation class "has ":

- **Bezeichnung (chapter "Description"):**

Enter a name.

For documentation purposes.

- **Representation (chapter "Description"):**

Define if the attribute values specified by the attribute 'Name' are displayed right from the edge middle point or beneath the edge middle point in the graphical representation.

Geben Sie an, ob die im Attribut 'Bezeichnung' ausgewählten Attributwerte rechts vom Kantenmittelpunkt oder unterhalb des Kantenmittelpunkts in der Modellgrafik angezeigt werden sollen.

- **Fontcolor (chapter "Description"):**

Wählen Sie die Farbe zur Anzeige der Übergangsbedingung bzw. Übergangswahrscheinlichkeit aus.

- **Description (chapter "Description"):**

Describe the characteristics of the relation.

The description will be used for documentation purposes.

Geben Sie eine charakterisierende Beschreibung ein.

Dient der Dokumentation.

- **Comment (chapter "Description"):**

Enter any comments about the relation.

The comments will be used for documentation purposes.

Geben Sie einen Kommentar ein.

Dient der Dokumentation.

- **Bezeichnung (chapter "Deutsch"):**

Enter a name.

For documentation purposes.

- **Beschreibung (chapter "Deutsch"):**

Geben Sie eine charakterisierende Beschreibung ein.

Dient der Dokumentation.

Describe the characteristics of the relation.

The description will be used for documentation purposes.

- **Kommentar (chapter "Deutsch"):**

Geben Sie einen Kommentar ein.

Dient der Dokumentation.

Enter any comments about the relation.

The comments will be used for documentation purposes.

3.14 Relation class "has"



This relation represents dependencies between elements of an IT system model. The element with the outgoing connector owns the other element. -----
----- Über diese Beziehungen werden Abhängigkeiten zwischen den Elementen eines IT systemmodells beschrieben. Das Element, von dem der Pfeil wegführt, besitzt das andere Element.

The following attributes are defined for the relation class "has":

- **Name (chapter "Description"):**
- **Representation (chapter "Description"):**
Define if the attribute values specified by the attribute 'Name' are displayed right from the edge middle point or beneath the edge middle point in the graphical representation.

Geben Sie an, ob die im Attribut 'Bezeichnung' ausgewählten Attributwerte rechts vom Kantenmittelpunkt oder unterhalb des Kantenmittelpunkts in der Modellgrafik angezeigt werden sollen.
- **Fontcolor (chapter "Description"):**
Wählen Sie die Farbe zur Anzeige der Übergangsbedingung bzw. Übergangswahrscheinlichkeit aus.
- **Description (chapter "Description"):**
Describe the characteristics of the relation.
The description will be used for documentation purposes.

Geben Sie eine charakterisierende Beschreibung ein.
Dient der Dokumentation.
- **Comment (chapter "Description"):**
Enter any comments about the relation.
The comments will be used for documentation purposes.

Geben Sie einen Kommentar ein.
Dient der Dokumentation.
- **Bezeichnung (chapter "Deutsch"):**

Enter a name.

For documentation purposes.

- **Beschreibung (chapter "Deutsch"):**

Enter a characterizing description.

For documentation purposes.

 Geben Sie eine charakterisierende Beschreibung ein.

Dient der Dokumentation.

- **Kommentar (chapter "Deutsch"):**

Geben Sie einen Kommentar ein.

Dient der Dokumentation.

 Enter any comments about the relation.

The comments will be used for documentation purposes.

3.15 Relation class "uses "



This relation represents dependencies between elements of an IT system model. The element with the outgoing connector uses the other element. -----

----- Über diese Beziehungen werden Abhängigkeiten zwischen den Elementen eines IT systemmodells beschrieben. Das Element, von dem der Pfeil wegführt, nutzt das andere Element.

The following attributes are defined for the relation class "uses ":

- **Name (chapter "Description"):**

- **Representation (chapter "Description"):**

Define if the attribute values specified by the attribute 'Name' are displayed right from the edge middle point or beneath the edge middle point in the graphical representation.

 Geben Sie an, ob die im Attribut 'Bezeichnung' ausgewählten Attributwerte rechts vom Kantenmittelpunkt oder unterhalb des Kantenmittelpunkts in der Modellgrafik angezeigt werden sollen.

- **Fontcolor (chapter "Description"):**

Part III

Wählen Sie die Farbe zur Anzeige der Übergangsbedingung bzw. Übergangswahrscheinlichkeit aus.

- **Description (chapter "Description"):**

Describe the characteristics of the relation.

The description will be used for documentation purposes.

Geben Sie eine charakterisierende Beschreibung ein.

Dient der Dokumentation.

- **Comment (chapter "Description"):**

Enter any comments about the relation.

The comments will be used for documentation purposes.

Geben Sie einen Kommentar ein.

Dient der Dokumentation.

- **Bezeichnung (chapter "Deutsch"):**

Enter a name.

For documentation purposes.

- **Beschreibung (chapter "Deutsch"):**

Geben Sie eine charakterisierende Beschreibung ein.

Dient der Dokumentation.

Describe the characteristics of the object.

The description will be used for documentation purposes.

- **Kommentar (chapter "Deutsch"):**

Geben Sie einen Kommentar ein.

Dient der Dokumentation.

Enter any comments about the relation.

The comments will be used for documentation purposes.

3.16 Relation class "Is dependent on"

This relation represents a general dependency between elements of an IT system model. -----
 ----- Diese Beziehung repräsentiert eine generelle Abhängigkeit zwischen den Elementen eines IT systemmodells.

The following attributes are defined for the relation class "Is dependent on":

- **Name (chapter "Description"):**

- **Representation (chapter "Description"):**

Define if the attribute values specified by the attribute 'Name (english)' are displayed right from the edge middle point or beneath the edge middle point in the graphical representation.

 Geben Sie an, ob die im Attribut 'Bezeichnung' ausgewählten Attributwerte rechts vom Kantenmittelpunkt oder unterhalb des Kantenmittelpunkts in der Modellgrafik angezeigt werden sollen.

- **Fontcolor (chapter "Description"):**

Choose a colour for the visualisation of the transition condition or transition probability.

- **Description (chapter "Description"):**

Describe the characteristics of the relation.

The description will be used for documentation purposes.

 Geben Sie eine charakterisierende Beschreibung ein.

Dient der Dokumentation.

- **Comment (chapter "Description"):**

Enter any comments about the object.

The comments will be used for documentation purposes.

 Geben Sie einen Kommentar ein.

Dient der Dokumentation.

- **Bezeichnung (chapter "Deutsch"):**

Enter a name.

For documentation purposes.

- **Beschreibung (chapter "Deutsch"):**

Geben Sie eine charakterisierende Beschreibung ein.

Dient der Dokumentation.

Describe the characteristics of the relation.

The description will be used for documentation purposes.

- **Kommentar (chapter "Deutsch"):**

Geben Sie einen Kommentar ein.

Dient der Dokumentation.

Enter any comments about the relation.

The comments will be used for documentation purposes.

3.17 Relation class "Owns"



Hint: There are no attributes defined for the relation class "Owns".

3.18 Relation class "has Note" (ADONIS BPMS BP Library 3.9)

.....

The relation "has Note" joins 1 object of any class (also "Note") with 1 object of the class "Note". It is used from any object to the "Note".

Hint: There are no attributes defined for the relation class "has Note".

3.19 Relation class "has Cross-reference"

—————▶

Hint: There are no attributes defined for the relation class "has Cross-reference".

3.20 Relation class "Is subordinated"



The relation "Is subordinated" connects 2 objects of the class "Organizational unit" hierarchically. The relation is used from the object which is super ordered to the lower ordered one.

The following attributes are defined for the relation class "Is subordinated":

- **Representation (chapter "Description"):**

Select if the relation should be visualized with or without an arrow.



Geben Sie an, ob die Beziehung mit oder ohne Pfeilspitze angezeigt werden soll.

3.21 Relation class "has Resource"



The relation "has Resource" connects one object of the class "Organizational unit" with 1 object of the class "Resource". It is used from the organizational unit to the resource.

Hint: There are no attributes defined for the relation class "has Resource".

3.22 Relation class "has position"



Hint: There are no attributes defined for the relation class "has position".

3.23 Relation class "Belongs to"



The relation "Belongs to" connects 1 object of the class "Performer" with 1 object of the class "Organizational unit". The relation is used from the performer to the organizational unit.

Hint: There are no attributes defined for the relation class "Belongs to".

3.24 Relation class "Is manager"



The relation "Is manager" connects 1 object of the class "Performer" with 1 object of the class "Organizational unit". The relation is used from the performer to the organizational unit.

Hint: There are no attributes defined for the relation class "Is manager".

3.25 Relation class "Has role"



The relation "Has role" connects 1 object of the class "Performer" with 1 object of the class "Role". The relation is used from the performer to the role.

Hint: There are no attributes defined for the relation class "Has role".

3.26 Relation class "Uses resource"



The relation "Uses resource" connects 1 object of the class "Performer" with 1 object of the class "Resource". The relation is used from the performer to the resource.

Hint: There are no attributes defined for the relation class "Uses resource".

3.27 Relation class "Is charged to"



The relation "Is charged to" connects 1 object of the class "Performer" with 1 object of the class "Cost center". The relation is used from the performer to the cost center.

Hint: There are no attributes defined for the relation class "Is charged to".

3.28 Relation class "Is cost center manager"



The relation "Is cost center manager" connects 1 object of the class "Performer" with 1 object of the class "Cost center". The relation is used from the performer to the cost center.

Hint: There are no attributes defined for the relation class "Is cost center manager".

3.29 Relation class "has Note" (ADONIS BPMS WE Library 3.9)



The relation "has Note" connects 1 object of the class "Organizational unit", "Performer", "Role", "Resource", "Cost center", "Aggregation" or "Note" with 1 object of the class "Note". The relation is used from any object to the note.

Hint: There are no attributes defined for the relation class "has Note".

4. Predefined queries and relation tables

The predefined queries are specific queries for defined model types which deliver results. Predefined relation tables are used to show relations between objects.

In the ADONIS BPMS application library predefined queries and relation tables are offered in the Analysis component (see chap. 4.1.1, p. 199) and the Evaluation component (see chap. 4.2, p. 211).

4.1 Analysis component

In the analysis component of the ADONIS BPMS application library 3.9 the following is available

- Queries:
 - Evaluation of the open questions in company maps (see chap. 4.1.1, p. 199)
 - Consistency checks on Business Process Models (see chap. 4.1.2, p. 200)
 - Predefined queries on Business Process Models (see chap. 4.1.3, p. 202)
 - Evaluation of the open questions in Business Process Models (see chap. 4.1.4, p. 203)
 - Predefined queries on Working Environment models (see chap. 4.1.5, p. 204)
 - Evaluation of the open questions in use case diagrams (see chap. 4.1.6, p. 206)
- Relation tables:
 - Activity-Resource table (see chap. 4.1.7, p. 207)
 - Activity-Document table (see chap. 4.1.8, p. 208)
 - Activity-Input-Document table (see chap. 4.1.8, p. 208)
 - Activity-Output-Document table (see chap. 4.1.10, p. 209)
 - Variable-Activity table (see chap. 4.1.11, p. 209)
- Role table (see chap. 4.1.12, p. 210)
- Organisational hierarchy table (see chap. 4.1.13, p. 210)

4.1.1 Evaluation of the open questions in company maps

To evaluate the open questions in company maps select in the menu **"Analysis"** the item **"Queries on Company maps"** and the sub-menu point **"Evaluation of the open questions in company maps"**.

In the window "Evaluation of the open questions in company maps - Model selection" select the models to be analysed and click on the OK button.

In the window "Evaluation of the open questions in company maps - Queries" (see fig. 3) the predefined query will be shown.

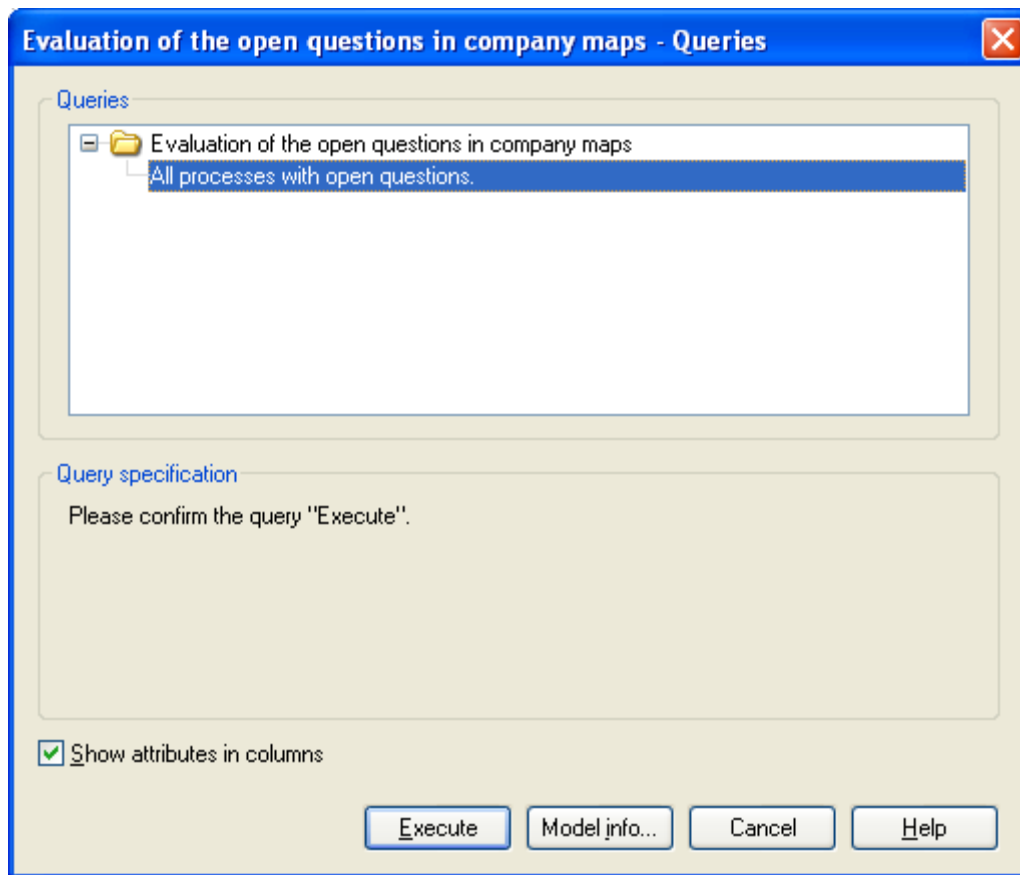

Figure 3: Evaluation of the open questions in company maps - Queries

Select the query "Evaluation of the open questions in company maps.", to show all processes which have input into the field "Open questions" and click on the button "Execute".

The result of your query will be shown in the ADONIS browser.

4.1.2 Consistency checks on Business Process Models

To perform consistency checks for Business Process Models select in the menu "Analysis" the item "Queries on Business Process Models" and the sub-menu point "Consistency checks on Business Process Models".

In the window "Consistency checks on Business Process Models - Model selection" select the models to be analysed and click on the OK button.

In the window "Consistency checks on Business Process Models - Queries" (see fig. 4) the predefined queries will be shown.

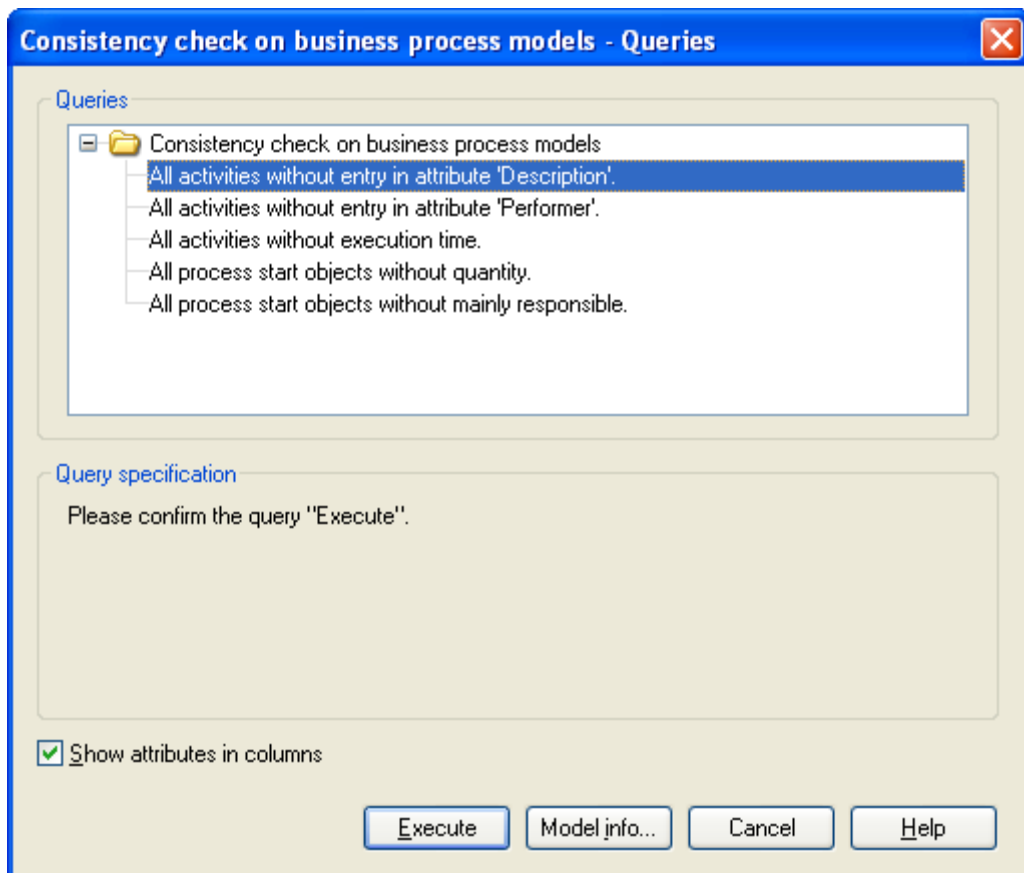

Figure 4: Consistency checks on Business Process Models - Queries

To run a consistency check select one of the predefined queries from the list "Queries".

The following queries for consistency checks are available:

- **All activities without entry in the attribute 'Description'.**
This query lists all activities which do not contain information in the attribute "Description".
- **All activities without entry in the attribute 'Performer'.**
This query lists all activities which have no performer assigned in the attribute "Performer".
- **All activities without Execution time.**
This query enables you to identify which activities have no execution time assigned.
- **All process start objects without quantity.**
This query will find all process start objects without a quantity.
- **All process start objects without mainly responsible.**
This query will identify all process start objects where no mainly responsible have been defined.

Run the consistency check by clicking on the button "**Execute**", the result of your query will be shown in the ADONIS browser.

4.1.3 Predefined queries on Business Process Models

To perform predefined queries for Business Process Models select in the menu "Analysis" the item "Queries on Business Process Models" and the sub-menu point "Predefined queries on Business Process Models".

In the window "Predefined queries on Business Process Models - Model selection" select the models to be analysed and click on the OK button.

In the window "Predefined queries on Business Process Models - Queries" (see fig. 5) the predefined queries will be shown.

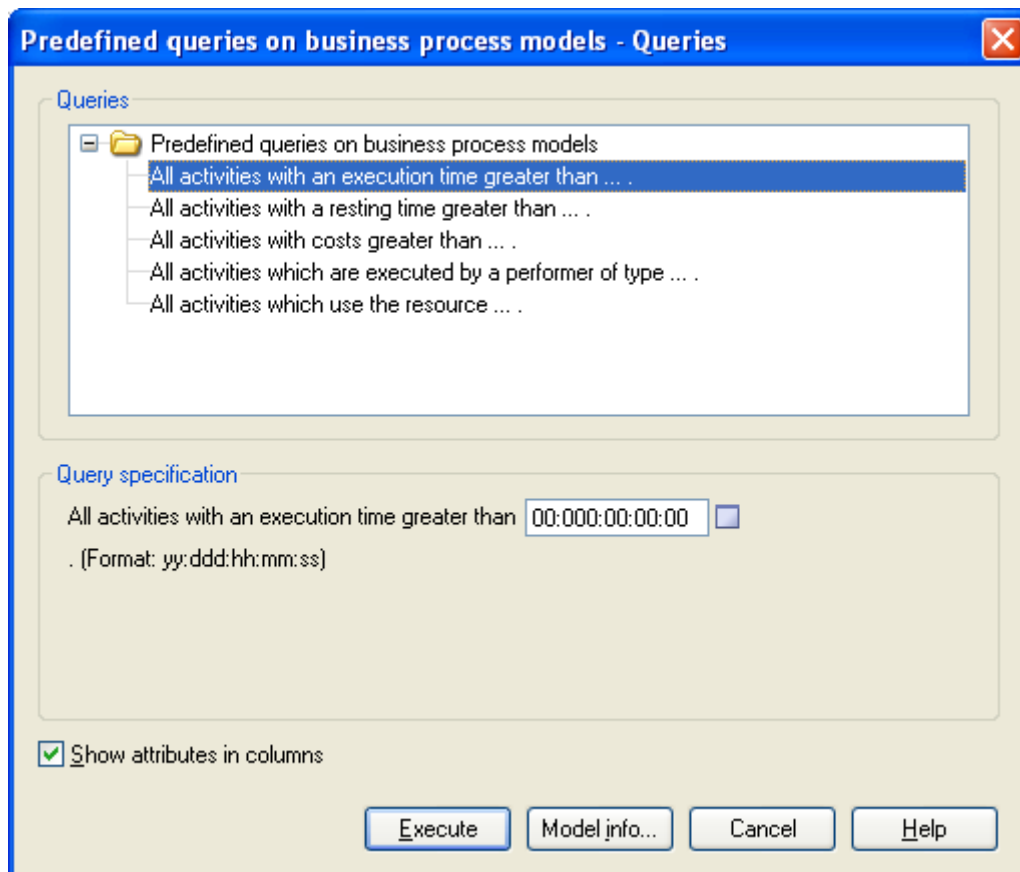

Figure 5: Predefined queries on Business Process Models - Queries

To run a predefined query select one from the list of predefined queries. In the next window of the query an empty input field (text with a gap) will be shown. Enter the necessary information (e.g. Execution time, Resting time, Costs, Type of Performer).

The following queries are available as predefined queries on Business Process Models:

- All activities with an execution time greater than *[input]*.

This query lists all activities with an execution time greater than the value provided.

Example: By providing the input "00:000:03:45:00" all activities will be shown with an execution time greater than 03 hour 45 minutes.

- All activities with a resting time greater than *[input]*.

This query lists all activities with a resting time greater than the value provided.

Example: By providing the input "00:000:05:20:00" all activities will be shown with a resting time greater than 05 hours 20 minutes.

- All activities with costs greater than *[input]* .

This query will determine all activities where the costs exceed the input value.

Example: Input the value "10000" to show all activities with costs higher than 10000,00.

- All activities which are executed by a type of performer *[input]* .

This query will determine all activities where a specific type of performer has been assigned.

Example: The input "Clerk" determines all activities which are performed by clerks.

- All activities which use the resource *[input]* .

This query will list all activities which use a specific type of resource for their execution.

Run the completed predefined query by clicking on the button "**Execute**"; the result of your query will be shown in the ADONIS browser.

By enabling the option "**Show attributes in columns**" the objects are shown in rows and the corresponding attributes in columns.

4.1.4 Evaluation of the open questions in Business Process Models

To evaluate the open questions in Business Process Models select in the menu "**Analysis**" the item "**Queries on Business Process Models**" and the sub-menu point "**Evaluation of the open questions in Business Process Models**".

In the window "Evaluation of the open questions in Business Process Models - Model selection" select the models to be analysed and click on the OK button.

In the window "Evaluation of the open questions in Business Process Models - Queries" (see fig. 6) the open questions will be shown.

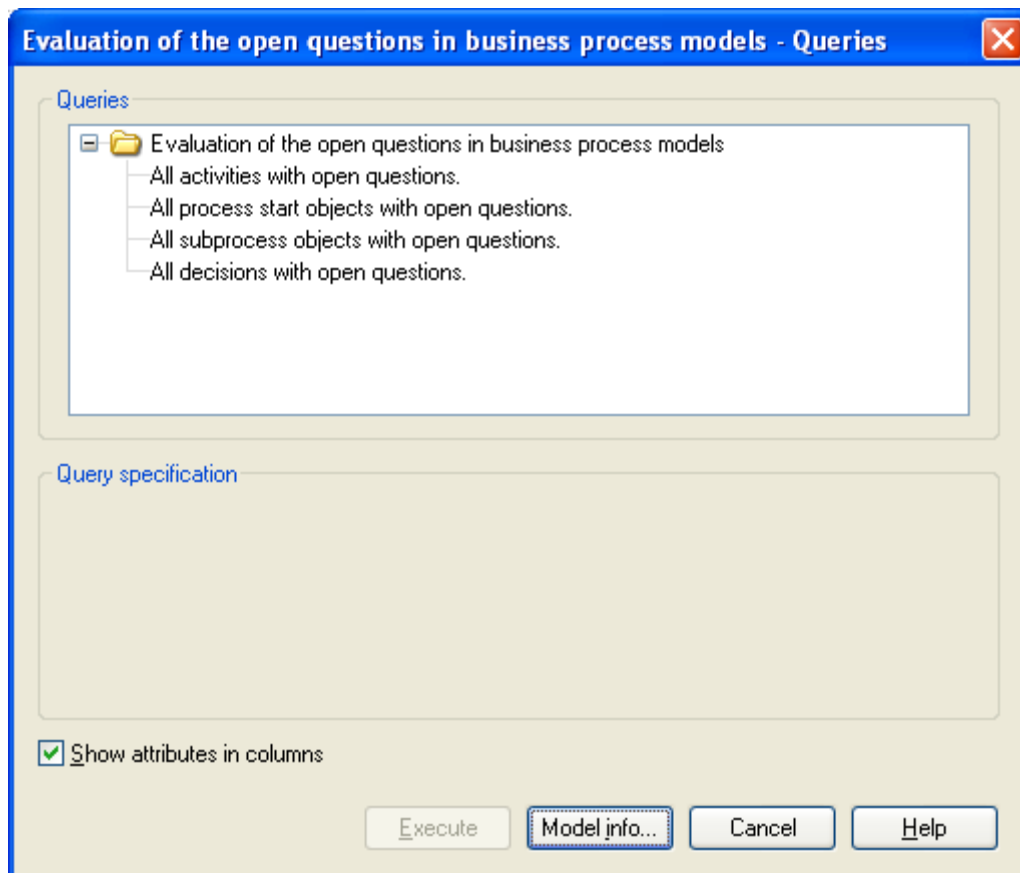

Figure 6: Evaluation of the open questions in Business Process Models - Queries

To analyse the open questions select one of the queries from the list and confirm it by clicking on the button "Execute".

The following queries are available for determining open questions in the ADONIS BPMS application library 3.9:

- **All activities with open questions**
This query lists all activities with text in the attribute "Open questions".
- **All process start objects with open questions**
This query determines all process start objects with text in the attribute "Open questions".
- **All subprocess objects with open questions**
This query enables you to identify all subprocess objects with text in the attribute "Open questions".
- **All decisions with open questions**
This query lists all decisions with text in the attribute "Open questions".

4.1.5 Predefined queries on Working Environment models

To run predefined queries for Working Environment models select in the menu "Analysis" the item "Queries on Working Environment models" and the sub-menu point "Predefined queries on Working Environment models".

In the window "Predefined queries on Working Environment models - Model selection" select the models to be analysed and click on the OK button.

In the window "Predefined queries on Working Environment models - Queries" (see fig. 7) the predefined queries will be shown.

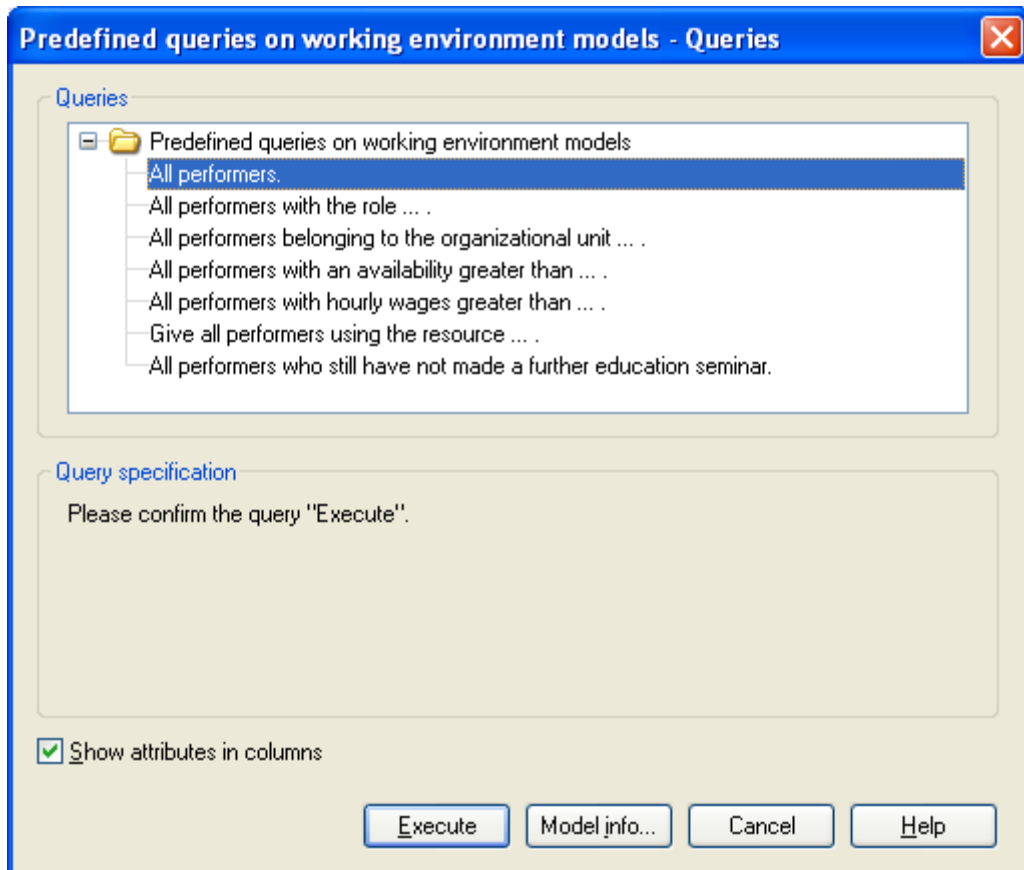

Figure 7: Predefined queries on Working Environment models - Queries

To run a query select one of the predefined queries from the list. In the next window of the query an empty input field (text with a gap) will be shown. Enter the necessary information (e.g. role, organisational unit).

The following predefined queries are available for Working Environment models:

- **All performers.**
This query lists all performers in the selected model(s).
- **All performers with the role. [input].**
This query lists all performers assigned to the selected role.
Example: By providing the input "Clerk" all performers assigned to the role clerk will be shown.
- **All performers belonging to the organisational unit [input].**
This query determines all performers who are members of a selected organisational unit.
Example: By providing the input "Sales" all performers belonging to the sales department in the selected (models) will be listed.
- **All performers with an availability greater than [input].**

Part III

This query determines all performers with an availability greater than the percentage value provided.

Example: By providing the input "50" all performers with an availability greater than 50 percent will be listed in the result spreadsheet.

- All performers with a hourly wage rate greater than *[input]*.

This query determines all performers with an hourly wage rate greater than the value provided.

Example: By providing the input "15" all performers with an hourly wage rate greater than 15,00 will be shown.

- All performers using the resource *[input]*.

This query lists all performers using a specific resource.

Example: By providing the input "Telephone" all performers are listed who use the telephone.

- All performers who still have not completed a further education seminar.

This query lists all performers who have not yet had any further education.

Run the completed predefined query by clicking the button "**Execute**"; the result of your query will be shown in the ADONIS browser.

By enabling the option "**Show attributes in columns**" the objects are shown in rows and the corresponding attributes in columns.

4.1.6 Evaluation of the open questions in Use Case diagrams

To evaluate open questions in use case diagrams select in the menu "**Analysis**" the item "**Queries on Use case diagrams**" and the sub-menu item "**Evaluation of the open questions in use case diagrams**".

In the window "Evaluation of the open questions in use case diagrams - Model selection" select the models to be analysed and click on the OK button.

In the window "Evaluation of the open questions in use case diagrams - Queries" (see fig. 8) the available queries will be displayed.

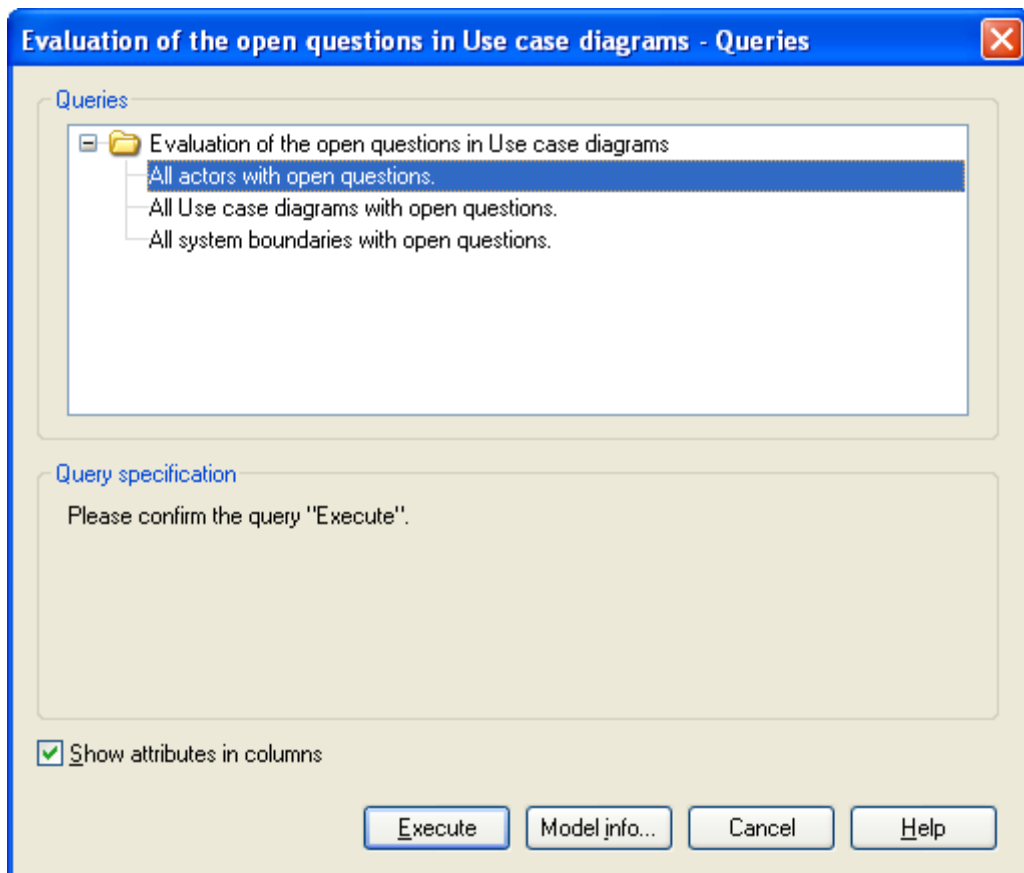

Figure 8: Evaluation of the open questions in use case diagrams - Queries

To analyse the open questions select a query from the list.

The following queries are available to determine open questions in use case diagrams:

- **All actors with open questions.**
This query will list all actors with text in the attribute "Open questions".
- **All use cases with open questions.**
This query will list all use cases with text in the attribute "Open questions".
- **All system boundaries with open questions.**
This query will list all system boundaries with text in the attribute "Open questions".

4.1.7 Activity-Resource table

Create an activity-resource table by selecting in the menu "**Relation tables**" the item "**Relation tables on Business Process Models**" and the sub-menu item "**Activity-Resource table**".

In the window "Activity-Resource table - Model selection" select the model for which you want to create the table and click on the OK button.

If the relations exist in the selected model, the window "Activity-Resource table for model <Model name>" (see fig. 9) will show the existing relations between activities and resources in the ADONIS browser.

	PC-1	PC-2	PC-3	PC-4	PC-5
Check application form		x			
File application			x		
Inform applicant				x	
Process application form	x				
Update vacation files			x		

Figure 9: Activity-Resource table (Example)

4.1.8 Activity-Document table

Create an activity-document table by selecting in the menu **"Relation tables"** the item **"Relation tables on Business Process Models"** and the sub-menu item **"Activity-Document table"**.

In the window "Activity-Document table - Model selection" select the model for which you want to create the table and click on the OK button.

If the relations exist in the selected model, the window "Activity-Document table for model <Model name>" (see fig. 10) will show the existing relations between activities and documents in the ADONIS browser.

	Application	Application data
Add completion remark	x	
Check application formally	x	
Check content of application data		x
Enter application data		x
Lay the application in the act of the day	x	

Figure 10: Activity-Document table (Example)

4.1.9 Activity-Input document table

Create an activity-input document table by selecting in the menu **"Relation tables"** the item **"Relation tables on Business Process Models"** and the sub-menu item **"Activity-Input document table"**.

In the window "Activity-Input document table - Model selection" select the model for which you want to create the table and click on the OK button.

If the relations exist in the selected model the window "Activity-Input document table for model <Model name>" (see fig. 10) will show the existing relations between activities and input documents in the ADONIS browser.

Application data	
complete and print application	x

Figure 11: Activity-Input document table (Example)

4.1.10 Activity-Output document table

Create an activity-output document table by selecting in the menu **"Relation tables"** the item **"Relation tables on Business Process Models"** and the sub-menu item **"Activity-Output document table"**.

In the window "Activity-Output document table - Model selection" select the model for which you want to create the table and click on the OK button.

If the relations exist in the selected model the window "Activity-Output document table for model <Model name>" (see fig. 10) will show the existing relations between activities and output documents in the ADONIS browser.

Application	
complete and print application	x

Figure 12: Activity-Output document table (Example)

4.1.11 Variable-Activity table

Create a variable-activity table by selecting in the menu **"Relation tables"** the item **"Relation tables on Business Process Models"** and the sub-menu item **"Variable-Activity table"**.

In the window "Variable-Activity table - Model selection" select the model for which you want to create the table and click on the OK button

If the relations exist in the selected model the window "Variable-Activity table for model <Model name>" (see fig. 13) will show the existing relations between variables and activities in the ADONIS browser.

	Check if account is blocked	Check signature	Decide on the release
Block	x		
Release			x
Signature		x	

Figure 13: Variable-Activity table (Example)

4.1.12 Role table

Create a role table by selecting in the menu **"Relation tables"** the item **"Relation tables on Working Environment models"** and the sub-menu item **"Role table"**.

In the window "Role table - Model selection" select the model for which you want to create the table and click on the OK button.

If the relations exist in the selected model the window "Role table for model <Model name>" (see fig. 14) will show the existing relations between performers and roles in the ADONIS browser.

	Enquiries Clerk	Service Clerk
Antonio Vivaldi	x	
Erich Holiday	x	
Henry Autumn		x
Jack Summer		x
Tom Winter		x

Figure 14: Role table (Example)

4.1.13 Organisational hierarchy table

Create an organisational hierarchy table by selecting in the menu **"Relation tables"** the item **"Relation tables on Working Environment models"** and the sub-menu item **"Organisational hierarchy table"**.

In the window "Organisational hierarchy table - Model selection" select the model for which you want to create the table and click on the OK button.

If the relations exist in the selected model the window "Organisational hierarchy table for model <Model name>" (see fig. 15) will show the existing relations between organisational units in the ADONIS browser.

	Admission administration	Patient service/Reception
Patient administration	x	x

Figure 15: Organisational hierarchy table (Example)

4.2 Evaluation component

The evaluation component in the ADONIS BPMS application library 3.9 provides:

- process-oriented queries on Business Process Models (see chap. 4.2.1, p. 211)
- Activity-oriented queries on Business Process Models (see chap. 4.2.2, p. 213)
- Queries on Working Environment models (see chap. 4.2.3, p. 214)

4.2.1 Process-oriented queries on Business Process Models

To run process-oriented queries on Business Process Models select in the menu "**Evaluation**" the item "**Evaluation queries on Business Process Models**" and the sub-menu point "**Process-oriented queries on Business Process Models**".

In the window "Process-oriented queries on Business Process Models - Model selection" select the model for which you want to create the table and click on the OK button.

In the window "Process-oriented queries on Business Process Models - Queries" (see fig. 16) the process related queries will be shown.

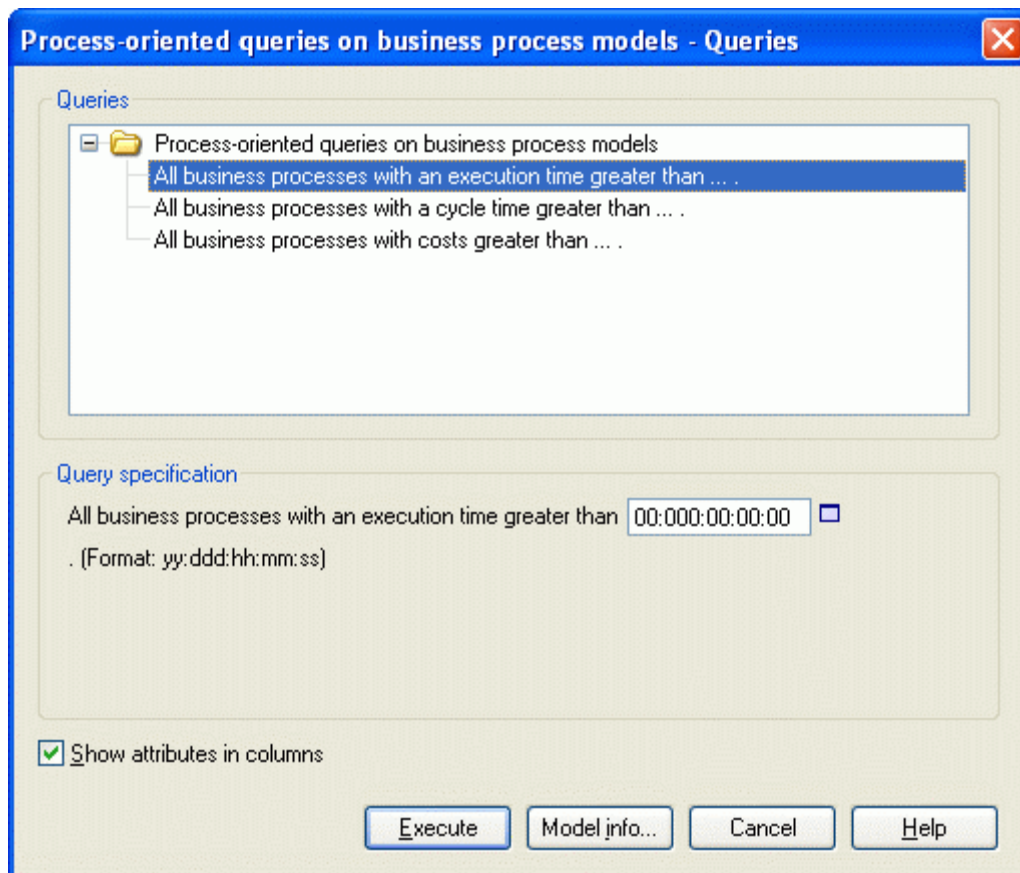

Figure 16: Process-oriented queries on Business Process Models - Queries

To run a query select one of the predefined queries from the list.

The following queries are available for process-oriented queries on Business Process Models:

- **All business processes with an execution time greater than [input] .**

This query lists all business processes with an execution time greater than the value provided.

Example: By providing the input "00:023:04:55:00" all business processes will be determined with an execution time greater than 23 days 04 hours and 55 minutes.

- **All business processes with a cycle time greater than [input] .**

The results of this query are all business processes with a cycle time greater than the value provided.

Example: By providing the input "00:000:00:05:00" all business processes with a cycle time greater than 5 minutes will be determined.

- **All business processes with costs greater than [input] .**

This query lists all business processes that have costs that are greater than the input value.

Example: By providing the input "50000" all business processes will be shown with costs greater than 50000.00.

Run the completed predefined query by clicking the button "**Execute**"; the result of your query will be shown in the ADONIS browser.

By enabling the option "**Show attributes in columns**" the objects are shown in rows and the corresponding attributes in columns.

4.2.2 Activity-oriented queries on Business Process Models

To run process-oriented queries on Business Process Models select in the menu "Evaluation" the item "Evaluation queries on Business Process Models" and the sub-menu item "Activity-oriented queries on Business Process Models".

In the window "Activity-oriented queries on Business Process Models - Model selection" select the model for which you want to create the table and click on OK.

In the window "Activity-oriented queries on Business Process Models - Queries" (see fig. 17) the activity-oriented queries will be shown.

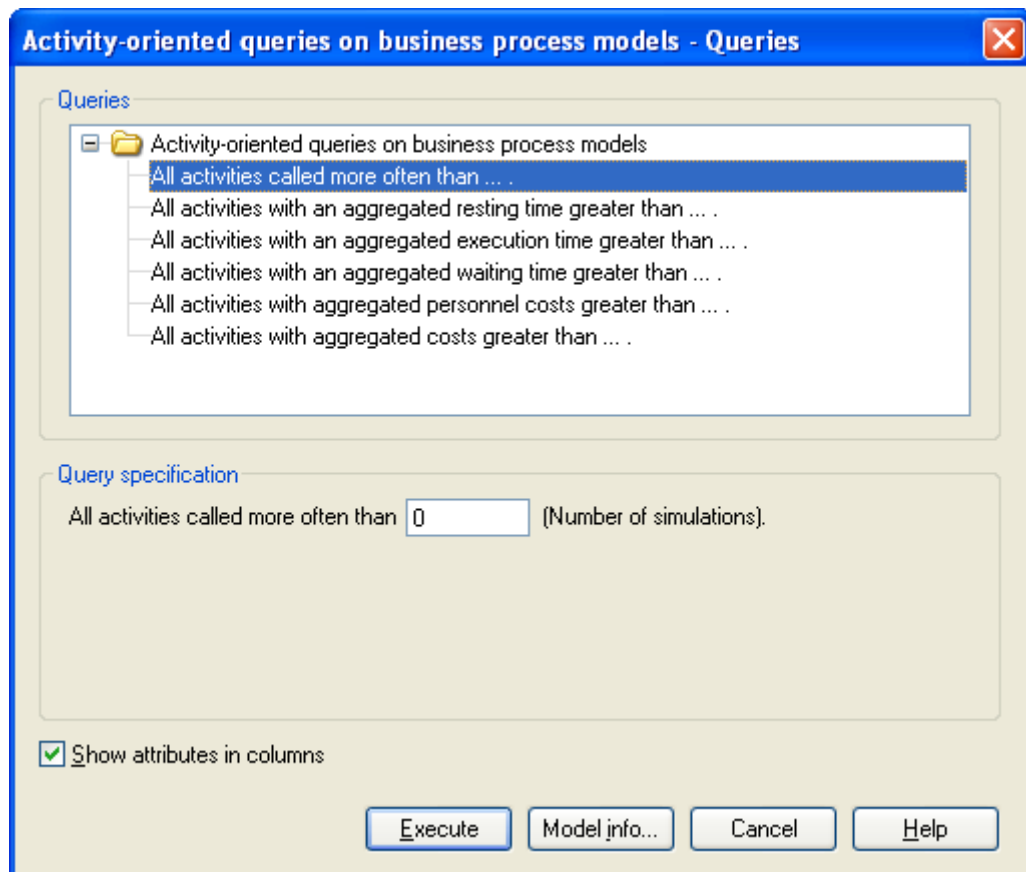

Figure 17: Activity-oriented queries on Business Process Models - Queries

To run a query select one of the predefined queries from the list. In the next window of the query an empty input field (text field) will be shown. Enter the necessary information (e.g. Aggregated execution time, Aggregated resting time, Aggregated costs, etc.).

The following queries are available for activity-oriented queries on Business Process Models:

- All activities called more often than *[input]*.

This query determines all activities which are "used" (called) more often than the value provided.

Example: Providing the value "25" all activities will be shown which are called more than 25 times.

- All activities with an aggregated resting time greater than *[input]*.

This query determines all activities with an aggregated resting time greater than the value provided.

Example: By providing the input "00:000:02:20:00" all activities are shown with an aggregated resting time greater than 2 hours and 20 minutes.

- All activities with aggregated costs greater than [input].

This query determines all activities with costs higher than the value provided.

Example: Enter "50" to determine all activities with costs greater than 50.00.

Run the completed predefined query by clicking the button "Execute"; the result of your query will be shown in the ADONIS browser.

By enabling the option "Show attributes in columns" the objects are shown in rows and the corresponding attributes in columns.

4.2.3 Queries on Working Environment models

To run process-oriented queries on Working Environment models select in the menu "Evaluation" the item "Evaluation queries on Working Environment models" and the sub-menu item "Queries on Working Environment models".

In the window "Queries on Working Environment models - Model selection" select the model for which you want to create the table and click on the OK button.

In the window "Queries on Working Environment models - Queries" (see fig. 18) the queries will be shown.

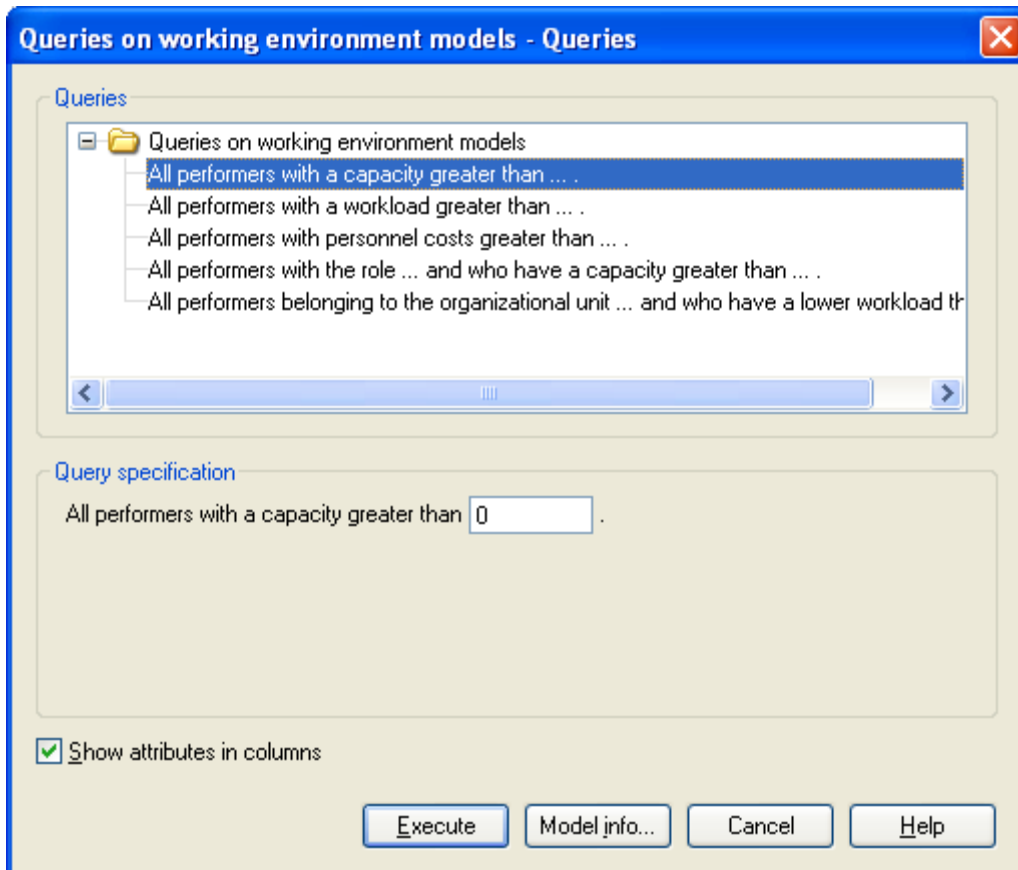

Figure 18: Queries on Working Environment models - Queries

To run a query select one of the predefined queries from the list. In the next window of the query an empty input field (text with a gap) will be shown. Enter the necessary information (e.g. Aggregated execution time, Aggregated resting time, Aggregated costs, etc.).

The following queries are available for Working Environment models:

- **All performers with a capacity greater than [input].**
This query determines all performers with a capacity greater than the value provided.
Example: Enter "1" to find all performers who are used beyond their capacity.
- **All performers with a workload greater than [input].**
This query determines all performers with a workload greater than the value provided.
Example: Enter "0.5" to find all performers who have a workload greater than 50%.
- **All performers with personnel costs greater than [input].**
This query determines all performers with personnel costs greater than the value provided.
Example: Enter "65000" to determine all performers with personnel costs greater than 65,000.00.
- **All performers with the role [input] and who have a capacity greater than [input].**
This query determines all performers with a specific role and a capacity greater than the value provided.
Example: Enter "secretary" and "1" to find all secretaries who are used beyond their capacity.
- **All performers belonging to the organisational unit [input] and who have a workload smaller than [input].**
This query will list all performers belonging to the specified organisational unit and who have a workload smaller than the values provided.
Example: Enter "PR" and "1" to find all PR employees who have a workload smaller than 100%.

Run the completed predefined query by clicking the button "**Execute**"; the result of your query will be shown in the ADONIS browser.

By enabling the option "**Show attributes in columns**" the objects are shown in rows and the corresponding attributes in columns.

5. Library specific functions

The library specific functions are defined in the ADONIS-BPMS-Application library 3.9 and are available in following components of ADONIS business process management toolkit:

- **Acquisition** (see chap. 5.1, p. 216)
- **Modelling** (see chap. 5.2, p. 218)
- **Simulation** (see chap. 5.3, p. 235)
- **Import/Export** (see chap. 5.5, p. 238)

5.1 Acquisition component

In the acquisition component the library specific functions are defined in the form of HOMER scenarios (see chap. 5.1.1, p. 216) supporting the data acquisition.

5.1.1 HOMER scenarios

For the data acquisition with HOMER you can either use one of the following scenarios or use the HOMER scenario manager to adapt the scenario according to your needs:

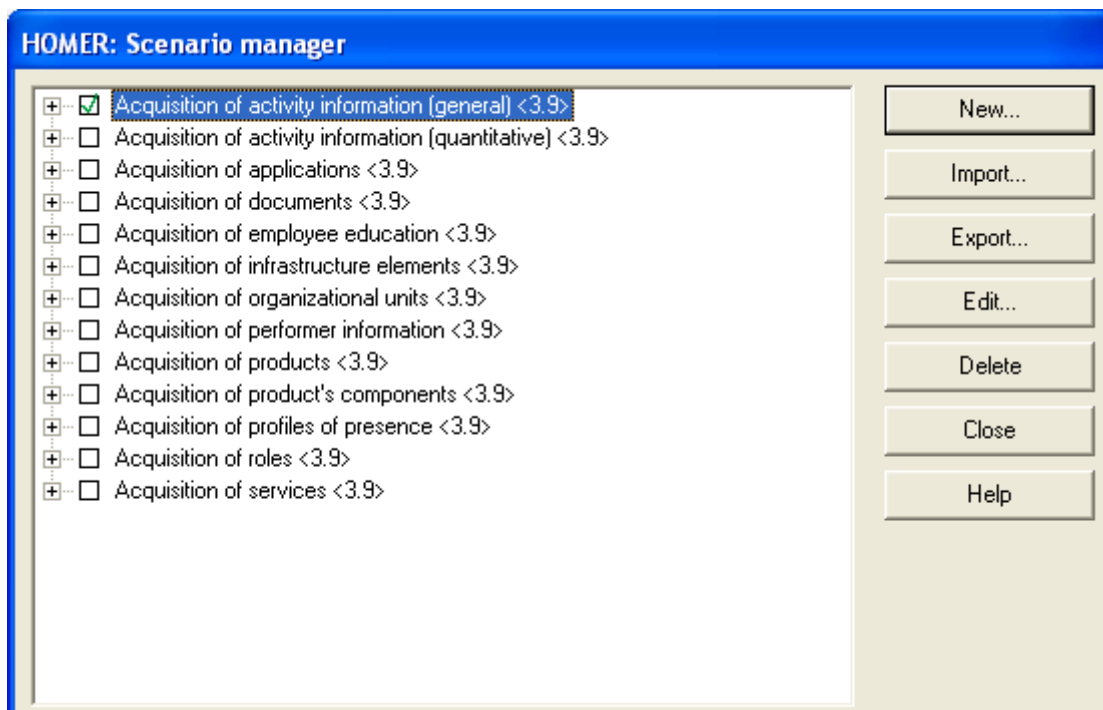

Figure 19: HOMER scenarios for ADONIS BPMS Application Library

- Acquisition of activity information (general)
- Acquisition of activity information (quantitative)

- Acquisition of profiles of presence
- Acquisition of performer information
- Acquisition of employee education
- Acquisition of documents
- Acquisition of organisational units
- Acquisition of roles

The **scenario "Acquisition of activity information (general)"** scenario collects information for activities in Business Process Models (see chap. 2.5, p. 44) and the following attributes:

- Description
- Comment

In addition it is possible to collect the author of a particular model.

The **"Acquisition of activity information (quantitative)" scenario** collects information for activities in Business Process Models (see chap. 1.3, p. 20) and the following attributes:

- Execution time
- Waiting time
- Resting time
- Transport time
- Costs
- EDP transaction costs
- EDP batch costs
- Print costs
- Postal costs

The **scenario "Acquisition of profiles of presence"** scenario collects attribute profiles of the class "Presence" with the following attributes:

- Days per week
- Hours per day

The **"Acquisition of performer information" scenario** collects information for performers in Working Environment models (see chap. 1.7, p. 30) and the following attributes:

- Description
- Comment

The **"Acquisition of employee education"** collects information for performers in Working Environment models (see chap. 1.7, p. 30) and their further education with the attributes:

Part III

- Seminar title
- Participation in

The **scenario "Acquisition of documents"** collects documents for the document models (see chap. 1.6, p. 29) and the following attributes:

- Description
- Comment

The **"Acquisition of organisational units"** scenario collects the organisational units for the Working Environment models (see chap. 2.11, p. 79) and the following attributes:

- Description
- Comment

The **"Acquisition of roles"** scenario collects roles for Working Environment models (see chap. 1.7, p. 30) and the following attributes:

- Description
- Comment

5.2 Modelling component

The modelling component provides the following library specific functionalities:

- Hierarchical model copy (copying model tree) (see chap. 5.2.1, p. 219)
- Class cardinality (see chap. 5.2.2, p. 219)
- Inter-model references (multiple models) (see chap. 5.2.3, p. 220)
- Number objects (see chap. 5.2.4, p. 222)
- Reset object numbering (see chap. 5.2.5, p. 224)
- Object conversion (see chap. 5.2.6, p. 224)
- Display visualised attributes in English/German (see chap. 5.2.7, p. 225)
- Monochrome view (see chap. 5.2.8, p. 230)
- Display incorrect transition probability (see chap. 5.2.9, p. 230)
- Show/hide responsible roles (see chap. 5.2.10, p. 230)
- Show/hide reference overview (see chap. 5.2.11, p. 231)
- Configure reference overview (see chap. 5.2.12, p. 231)
- Change modelling direction (see chap. 5.2.13, p. 231)
- Page layout (see chap. 5.2.14, p. 232)
- Process Stepper (see chap. 5.2.15, p. 232)

5.2.1 Hierarchical model copy

Copying a model tree allows the creation of a copy of a Business Process Model or a company map including all referenced submodels. The model tree copies can be put into the selected model group.

After selecting the menu option "Hierarchical model copy" in the menu "Model" a Business Process Model or a company map should be chosen. Subsequently the goal model group should be marked and a version number for the copies of the models should be entered.

5.2.2 Class cardinality

The table (see Table 1) lists all classes with defined cardinality rules. Cardinality rules help to determine how many objects should be contained in the model and how many incoming and outgoing connectors of relation classes should be assigned to the object.

Hint: During cardinality check (Menu "Model" - item "Check cardinalities") models are examined with respect to defined cardinality rules.

Hint: Cardinality checks do not occur during modelling, but it has to be performed explicitly. I.e. while modelling you do not need to consider cardinality rules (modelling can also be performed without considering cardinality rules).

Class	Description
Activity (Business Process Model)	At least one incoming connector of relation "subsequent" has to lead to the object and exactly one connector of relation "Subsequent" should lead out from the object. At most one connector of relation "uses" is allowed to come out from the object. Connectors of the relation class "has cross-reference" may be used only for connecting objects of the class "Cross-reference".
Cost center (Working Environment model)	A maximum one incoming connector of relation "is cost center manager" is allowed to lead into the object model. Connectors of the relation class "has cross-reference" may be used only for connecting objects of the class "Cross-reference".
Decision (Business Process Model)	At least one incoming connector of relation "subsequent" has to lead into the object and at least two objects of relation "subsequent" have to come out from the object. Connectors of the relation class "has cross-reference" may be used only for connecting objects of the class "Cross-reference".
Merging (Business Process Model)	At least two incoming connectors of relation "subsequent" have to lead into the object and exactly one connector of relation "Subsequent" has to come out from the object. Connectors of the relation class "has cross-reference" may be used only for connecting objects of the class "Cross-reference".
Parallelity (Business Process Model)	At least one incoming connector of relation "subsequent" has to lead into the object and at least two object of relation "subsequent" have to come out from the object. Connectors of the relation class "has cross-reference" may only be used for connecting objects of the class "Cross-reference".
Performance indicator overview (Company Map and Business Process Model)	A maximum of one object of relation "performance indicator overview" is allowed in a model. No connector of relation "owns" is allowed to come out from the object.

	Connectors of the relation class "has cross-reference" may be used only for connecting objects of the class "Cross-reference".
Process start (Business Process Model)	There must be exactly one "process start" in a model. No connector of relation class "subsequent" is allowed to come into the object and exactly one should come out from the object. Connectors of the relation class "has cross-reference" may be used only for connecting objects of the class "Cross-reference".
Subprocess (Business Process Model)	At least one incoming connector of relation "subsequent" has to lead into the object and at least one object of relation "subsequent" has to come out from the object. Connectors of the relation class "has cross-reference" may be used only for connecting objects of the class "Cross-reference".
Variable (Business Process Model)	At least one incoming connector of relation "sets variable" has to lead to the object. Connectors of the relation class "has cross-reference" may be used only for connecting objects of the class "Cross-reference".
Random generator (Business Process Model)	At least one incoming connector of relation "sets variable" should lead out from the object. At least one incoming connector of relation "sets" should lead out from the object. Connectors of the relation class "has cross-reference" may be used only for connecting objects of the class "Cross-reference".

Table 1: Description of the cardinality rules

5.2.3 Inter-model references (multiple models)

This function checks if outgoing references (in any number of models and model types) are still valid (not broken) or if there are invalid references (broken). In addition, it is possible to open source or target models directly from the result window to fix the problem.

Checking inter-model references

Select item "**Inter-model references (multiple models)**" from the "**model**" menu. A window with the model hierarchy appears (see fig. 20).

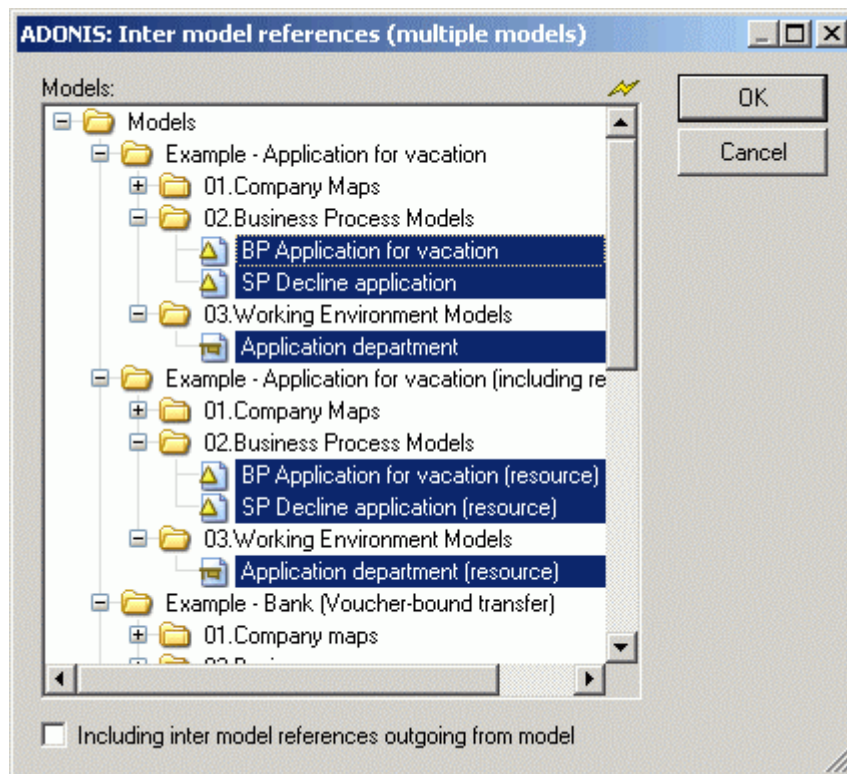

Figure 20: Model selection for checking references

Select models that you want to check. The option **"including inter-model references outgoing from the model"** will check all models in the model hierarchy. Click **"OK"** to begin.

ADONIS will then check all references of the selected models. It may take some time depending on the data size and computer's computing capability. Afterwards a window with a list of all references appears (valid and broken ones). To improve the result view you can expand or collapse branches (see fig. 21).

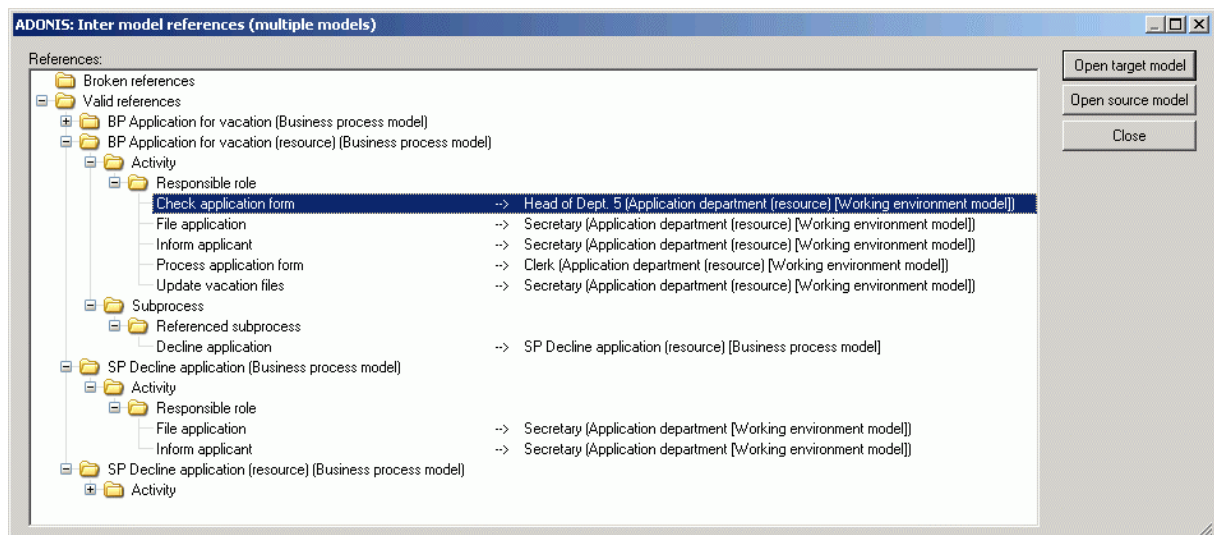

Figure 21: Result window (without broken references)

It is possible to open (in the background) the source or target model of a displayed reference (with write access). To do so, click on the reference and on the button **"open target model"** or **"open source model"**. The relevant object will be highlighted in the model (see fig. 22).

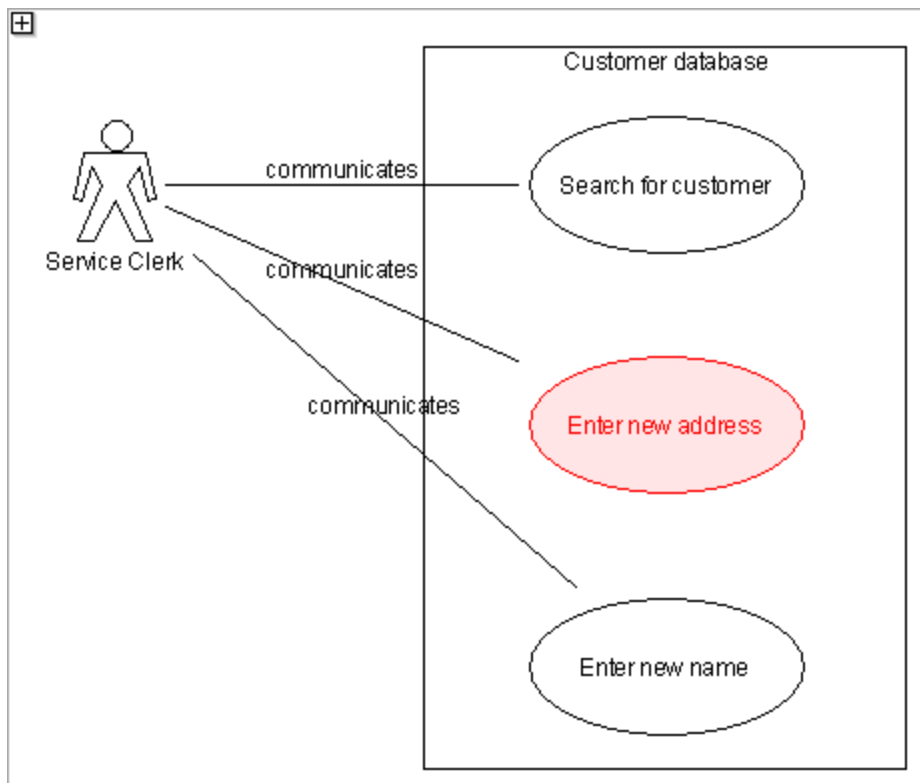

Figure 22: Target model (Highlighted use case "Enter new address")

5.2.4 Number objects

The function "number objects" assigns a unique number with respect to its position in the diagram to the objects of model type "Business Process Model", "Company Map" and "Working Environment model".

The numbering function is defined for objects of the following classes:

- Business Process Models (using the relation "Subsequent")
 - **Process start**
 - **Subprocess**
 - **Activity**
 - **Decision**
 - **Parallellity**
 - **Merging**
 - **End**
- Company Maps (using the relation "Has process")
 - **Process**
- Working Environment models (using the relation "Is subordinated")
 - **Organisational unit**

The number that is assigned to the object is stored in the attribute "Order" and at the same time it is displayed in object's graphical representation.

Performing numbering

In menu "edit", select the item "update attributes" and its sub menu item "Number objects".

Objects will be numbered and the object number will be displayed in graphical form (see fig. 23).

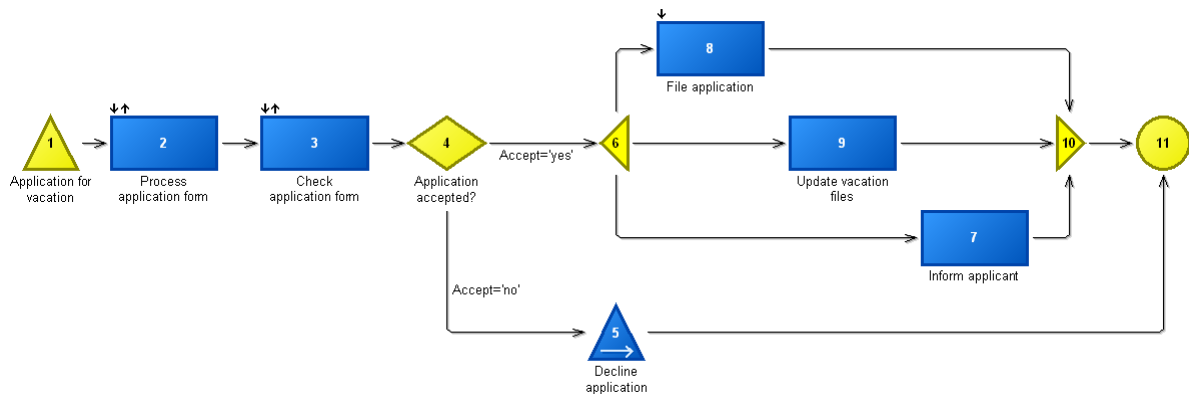

Figure 23: Numbered objects in a Business Process Model

All newly numbered objects will be listed in the window "enumeration - info" (see fig. 24).

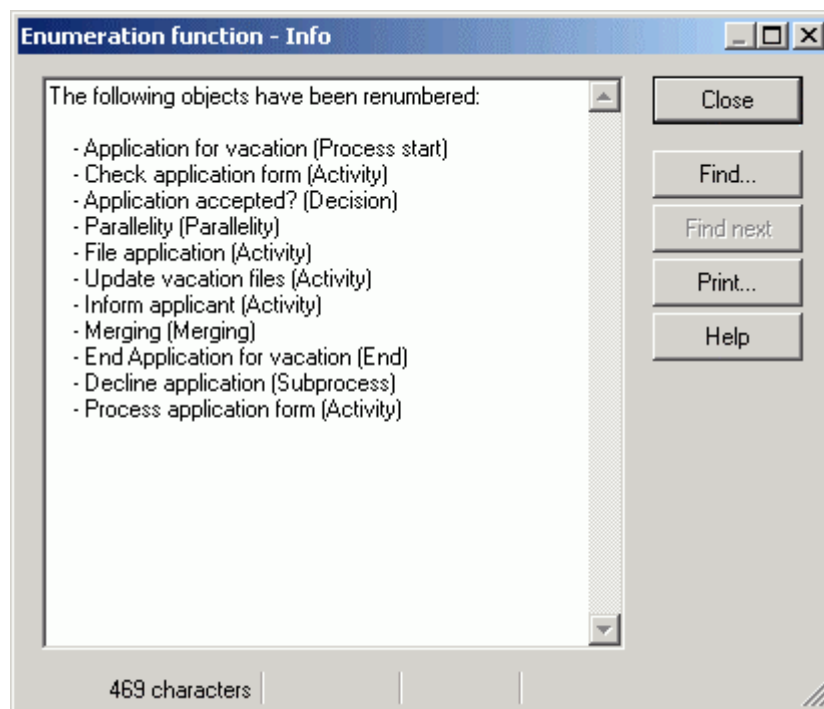

Figure 24: List of numbered objects

Hint: At any time you can undo (see chap. 5.2.5, p. 224) the object numeration.

Hint: The object numeration should always be done **before** generation of Word documentation (see chap. 5.5.2, p. 240). It is very important in the business process models, where object description could be generated with respect to the numbering order, therefore, it makes documentation easier to read.

5.2.5 Reset object numbering

The function "reset object numbering" removes numbers from objects (see chap. 5.2.4, p. 222) that are located in the actual model. The value of particular objects will be set to null in the attribute "order" and numbering will be removed from the model's graphical representation.

To reset object numbering, select in menu "edit", the item "update attributes" and its sub menu item "reset object numbering". Reset will be followed by an appropriate safety question (see fig. 25).

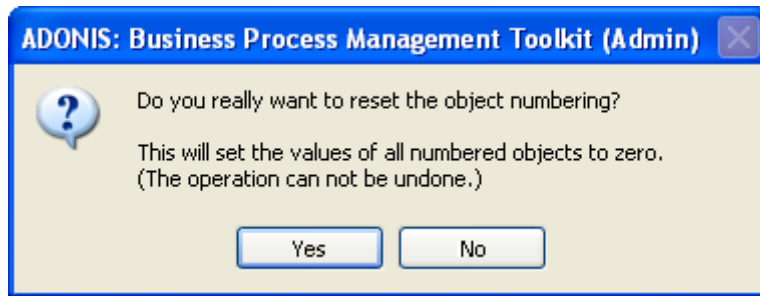

Figure 25: Security question before resetting the object numbers

Click on the button "yes" to continue. The object numbering in the model will be set to null and numbers displayed in the model's graphical representation will be deleted (see fig. 23).

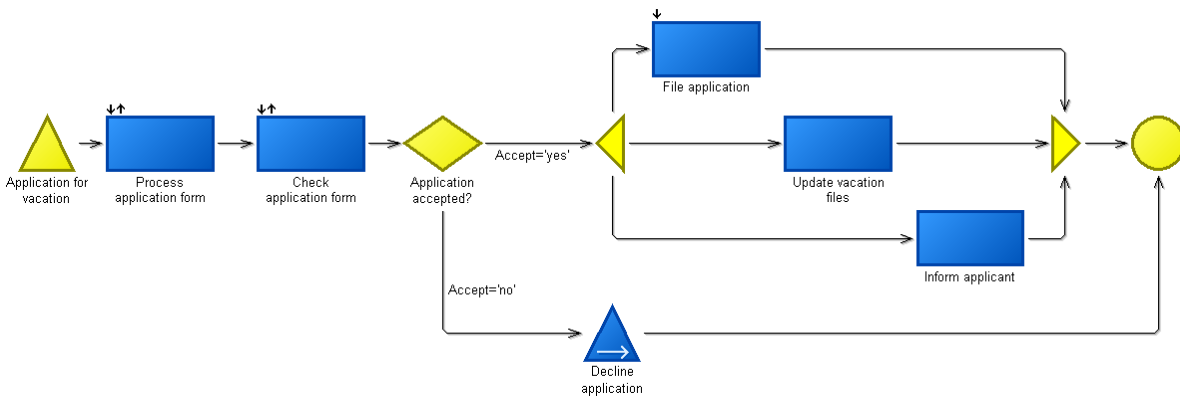

Figure 26: Unnumbered objects in a Business Process Model

5.2.6 Object conversion

In Business Process Models, it is possible to convert an object of the class "activity" into an object of the class "subprocess" and the other way around..

By converting an activity into a subprocess, it is possible to model the activity in detail (by presenting the activity as a subprocess). While converting a subprocess into an activity, it is possible to reduce the complexity of the process. It is very useful when going through simulations and analysing its results, as the results of subprocesses cannot be calculated separately, but taken over as an aggregation.

During object conversion the following information (attributes) will be over taken:

- "Activity" <-> "Subprocess"
 - Name (Description)
 - Order (Description)

- Description (Description)
- Commentary (Description)
- Questions (Description)
- Performer (working environment)

● **"Subprocess" --> "Activity"**

- Located Execution time (evaluation result) --> Execution time (time/Costs)
- Estimated waiting time (evaluation result) --> Waiting time (time/Costs)
- Estimated resting time (evaluation result) --> Resting time (time/Costs)
- Estimated transport time (evaluation result) --> Transport time (time/Costs)
- Estimated Costs (evaluation result) --> Costs (time/Costs)

Hint: The evaluation results in the subprocess contain the (taken over) simulation result of referenced processes. Pay attention to the referenced values (e.g. per year, per process) in the simulation result.

Hint: While converting a subprocess into an activity, the referenced process will be saved internally, so that during re-conversion into a subprocess, the reference will be displayed again.

Performing object conversion

To convert the object of class "activity" into the object of class "subprocess" select from the object's context menu (right mouse click) item **"convert"** and then its sub menu item **"subprocess"**.

To convert the object of class "subprocess" into the object of class "activity" select from the object's context menu (right mouse click) item **"convert"** and then its sub menu item **"activity"**.

5.2.7 Display visualised attributes in English/German

By default, visualised attributes (object names, notes, random generators etc.) are displayed in English (see fig. 27).

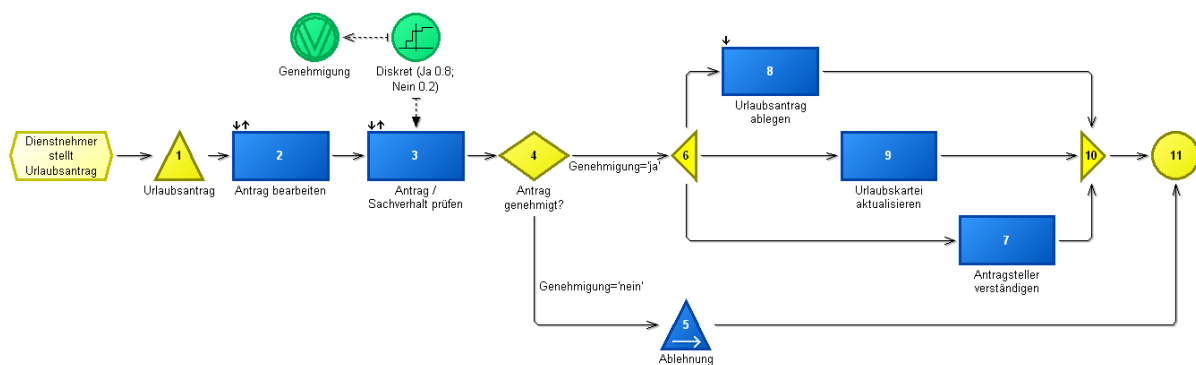

Figure 27: Model representation in English

Additionally, it is possible - after successful translation of attributes (see chap. 5.2.7.1, p. 226) - to display those attributes in German (see fig. 28).

Part III

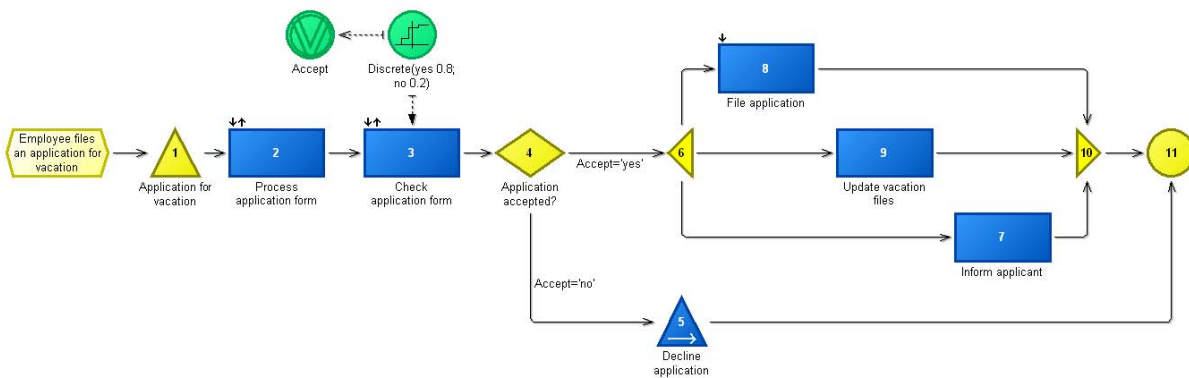

Figure 28: Model representation in German

Hint: Before visualising attributes in German (see chap. 5.2.7.2, p. 228), see requirements to change a language (see chap. 5.2.7.1, p. 226).

5.2.7.1 Requirements

When visualising the attribute value, the attribute value of a particular object (at least the value of the attribute 'name') is displayed on the drawing area. In order to display German attribute values, it is necessary to translate the other attributes.

To change the attribute language the following requirements must be satisfied:

- All models that will be translated have to have write access.
- All attribute values that will be visualised on the drawing area, have to have corresponding (German) attribute translated (see p. 226).
- Optionally, the attributes "description" and "comment" can be translated in the model documentation (see p. 228) (for example HTML documentation).

Requirements for model representation

To show attributes in German the following objects' attributes need to be translated:

Class	Attribute (English)	Attribute (German)
Process start	Name	Bezeichnung
Subprocess	Name	Bezeichnung
Activity	Name	Bezeichnung
Decision	Name	Bezeichnung
Parallelism	Name	Bezeichnung
Merging	Name	Bezeichnung
End	Name	Bezeichnung
Variable	Name	Bezeichnung
Random generator	Info for Value of Random Generator	Wert
Resource (BP-Model)	Name	Bezeichnung
Process	Name	Bezeichnung

Class	Attribute (English)	Attribute (German)
Document	Name	Bezeichnung
Organizational unit	Name	Bezeichnung
Performer	Name	Bezeichnung
Role	Name	Bezeichnung
Resource (WE-Model)	Name	Bezeichnung
Cost centre	Name	Bezeichnung
Use case	Name	Bezeichnung
Actor	Name	Bezeichnung
System boundary	Name	Bezeichnung
Note	Note	Text
Aggregation	Name	Bezeichnung

Table 2: Visualized objects' attributes in English/German

Hint: In the object of the class "random generator" the value is translated as text only i.e. during simulation, the expression entered in the attribute "Value" (in German) is taken into account during analysis.

To show attributes fully in German the following connectors' attributes need to be translated.

Relation	Attribute (English)	Attribute (German)
Subsequent	Info for transition condition	Bezeichnung
communicates	Name	Bezeichnung
contains	Name	Bezeichnung
extends	Name	Bezeichnung
Generalisation	Name	Bezeichnung
uses	Name	Bezeichnung

Table 3: Visualized connectors' attributes in English/German

Hint: In the connector of the relation "Subsequent", the transition condition is translated as text only i.e. during simulation, the expression entered in the attribute "transition condition" (in German) is taken into account during analysis.

ATTENTION: While using model references (for example a referenced process in a company map), model names (see p. 227) should be translated in the model attribute "keywords"

Translation of model names

Translation of model names is necessary if model references (for example subprocess in the business process models, process in company map) have to be used.

In the model references, the name of the model is used instead of object name that is contained in the reference.

The model name translation has to be done in the model attribute "denomination" (see fig. 29). To translate, select the menu item **"model attributes"** (or <Alt>+"Enter") from the **"model"** menu.

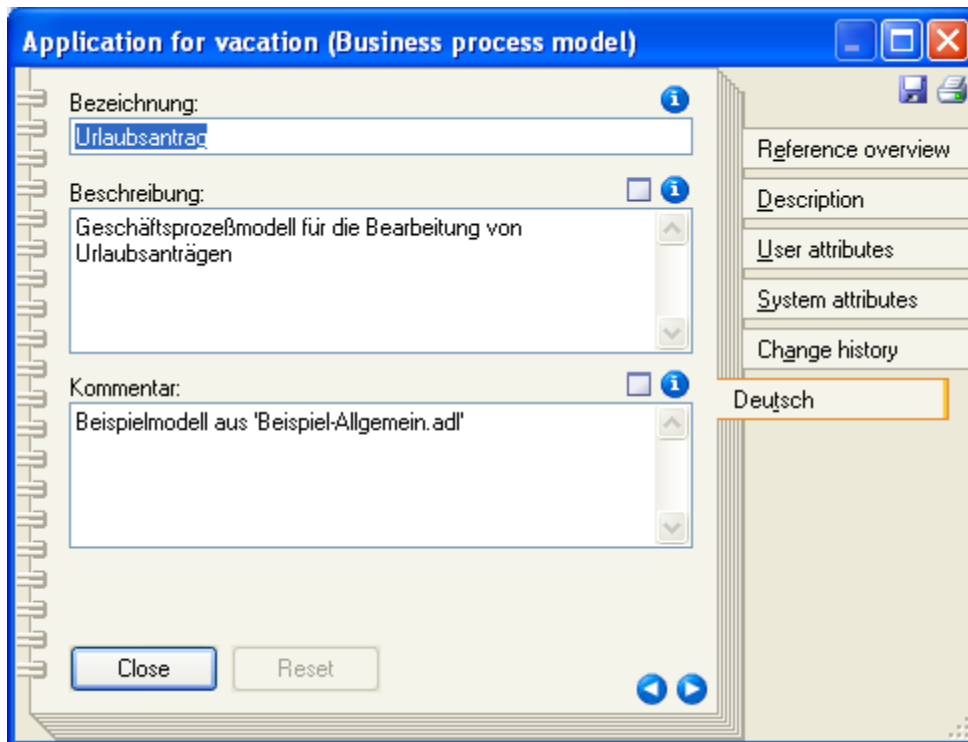

Figure 29: Model names translation

Requirements for documentation

Besides the translation of visualised attribute's values, it is also possible to translate the attributes "description" and "comments" into the corresponding attributes "Beschreibung" and "Kommentar".

It is very important, if you generate model documentation, with the language set to "German".

5.2.7.2 Implementation

Hint: You must have write access to models you wish to translate.

To change the language of visualised attributes, select the item **"views"** from the menu **"view"** and its sub menu item **"Select attribute visualisation language"**.

All opened models will be listed in the window "select language - model selection" (see fig. 30).

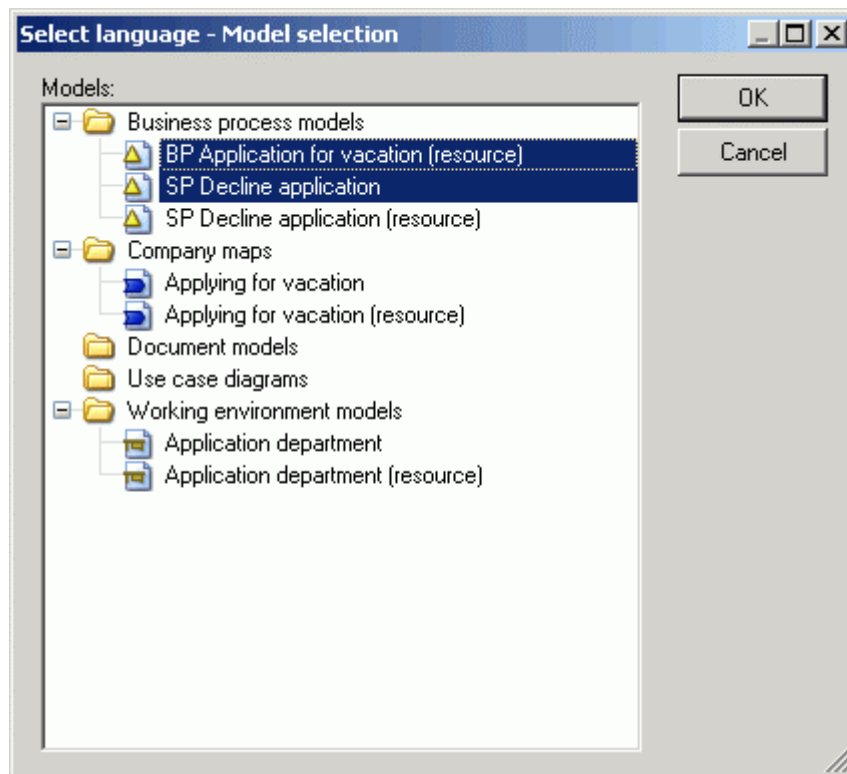

Figure 30: Selecting models for language settings

Select the models you want to use and click the OK button.

Select the language for the visualised attribute values in the window "select language" (see fig. 31).

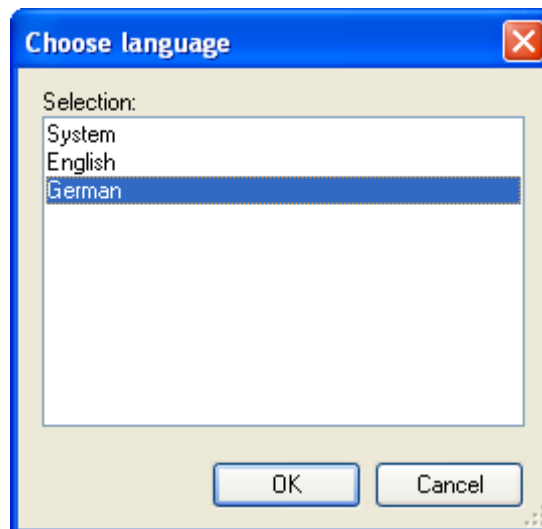

Figure 31: Language selection window

Hint: Choosing menu option "system" automatically changes the UI language (to the one chosen at ADONIS startup).

Click the OK button to continue.

An appropriate message will be displayed after successful language selection.

Note:

When selecting the language, the attribute "key words" with appropriate identifier (`LANGUAGE='DE'` ; for German or `LANGUAGE='EN'` ; for English) automatically pops-up. This identifier is further used to generate model documentation with the current set language.

5.2.8 Monochrome view

The monochrome view allows the representing of models in grayscale (see fig. 32) instead of full-colour representation.

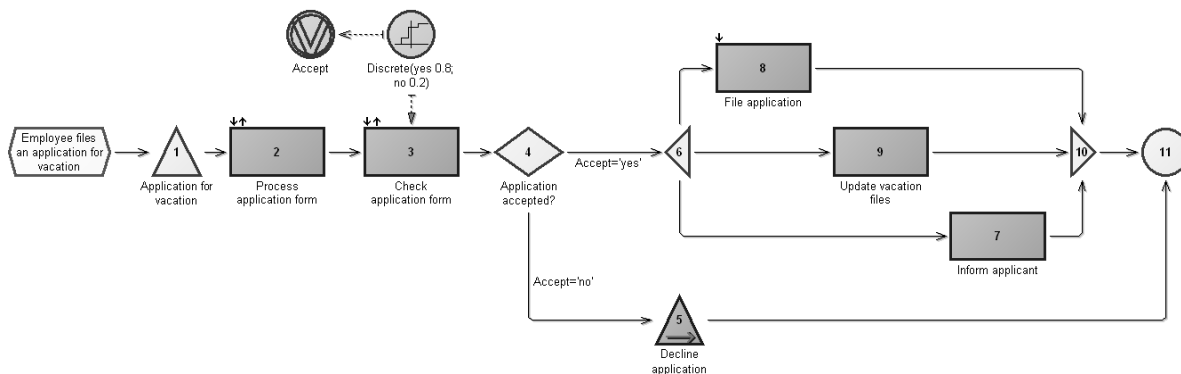

Figure 32: Model in monochrome view (example)

To present all models in grayscale please select the menu option "View", "Views" and the point of submenu "Monochrome view". When this option is selected a checkmark appears next to the point of submenu.

Hint: The representation in grayscale is possible for all models

5.2.9 Display incorrect transition probability

Visualizing incorrect transition probabilities supports you while modelling Business Process Models for analytical evaluation purposes (analysis component).

Activating this function in the menu "View" - menu option "Views" - point of submenu "Display incorrect transition probability" indicates decisions with incorrect transition probabilities with the red exclamation mark. In order to be correct transition probabilities of the connectors coming from the decision **must add up to one**.

5.2.10 Show/hide responsible roles

The function "Show responsible roles" (menu "View" - menu option "Views" - "Show responsible roles") allows showing responsible roles in several Business Process Models.

Hint: The Business Process Models must be loaded with write permission.

Activating the function "Show responsible roles" automatically sets attribute "Show responsible role" value to "Yes".

The function **"Hide responsible roles"** (menu "View" - menu option "Views" - "Hide responsible roles") allows hiding responsible roles in several Business Process Models.

Hint: The Business Process Models must be loaded with write permission.

Activating the function **"Hide responsible roles"** automatically sets attribute "Show responsible role" value to "No".

5.2.11 Show/hide reference overview

The function **"Show/hide reference overview"** (menu "View" - menu option "Views" - "Show/hide reference overview") allows showing and hiding the reference overview.

5.2.12 Configure reference overview

The function **"Configure reference overview"** (menu "View" - menu option "Views" - "Configure reference overview") allows adjusting the reference overview in the current Business Process Model.

After choosing the submenu point the window "Configure reference overview" (see fig. 33) appears.

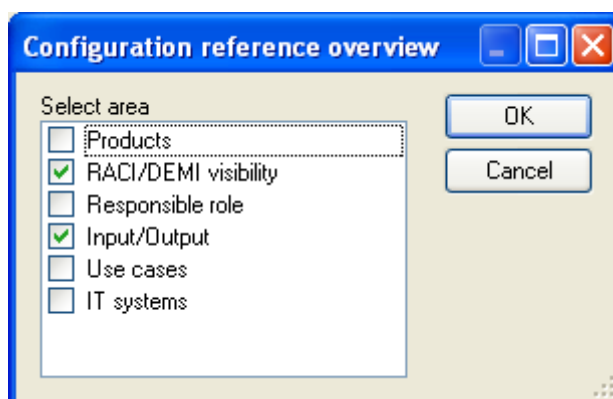

Figure 33: Configure reference overview

Activate () or deactivate () areas by clicking their checkboxes.

Hint: If no area is activated, no reference overview will be displayed.

5.2.13 Change modelling direction

The function **"Change modelling direction"** (menu "View" - menu option "Views" - "Change modelling direction") allows changing modelling direction in the selected Business Process Models.

The current model direction (horizontal i.e. from left to right or vertical i.e. from top to down) is indicated in the notebook of the model attributes in the chapter reference overview.

Changing the modelling direction causes the following changes in the graphical representation of models:

- Parallelity and Merging objects are represented corresponding to the direction;
- TheThe reference overview (see chap. 5.2.11, p. 231) objects are shown in the top of the model (horizontal modelling direction) or on the left sight of the model (vertical modelling direction).

5.2.14 Page layout

The option "full page (without header and footer)" prints the model without a header and footer (see fig. 34). The option "ADONIS BPMS page layout", adds a header and footer to the printing document.

Reference overview	Clerk	Clerk	Secretary	Secretary	Clerk
R					
A	Head of Dept. 5	Head of Dept. 5	Head of Dept. 5	Head of Dept. 5	Head of Dept. 5
C					
I					Secretary
In	Application for vacation	Application for vacation (processed)		Application for vacation (approved)	
Out	Application for vacation (processed)	Application for vacation (approved)	Application for...		

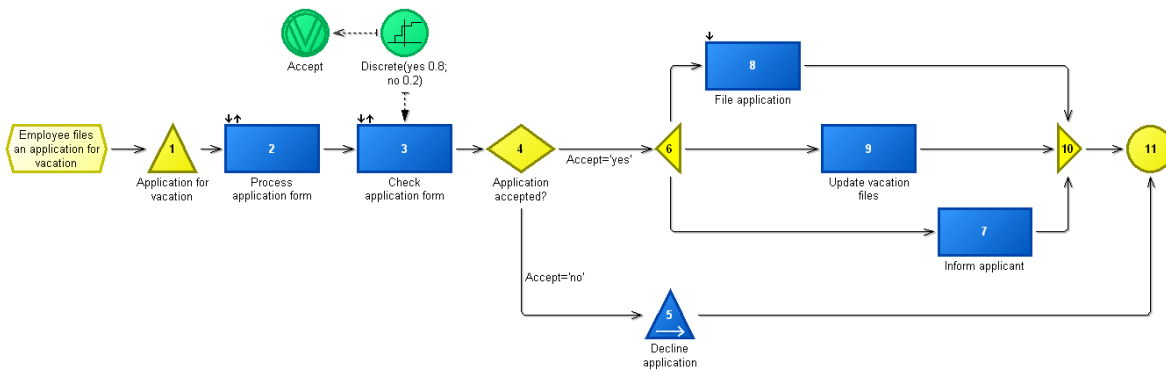

Figure 34: Page layout "full page (without header and footer) "

5.2.15 Process Stepper

The process stepper is a small tool that animates the process flow and also allows to correctly reconstruct the execution time of each process path, each decision can be made by the user. The following functions are available:

- Process animation (see chap. 5.2.15.1, p. 233)**
Starts the process flow, the result can be saved.
- Play back process animation (see chap. 5.2.15.2, p. 234)**
Open and play process animation.
- Remove marking of objects (see chap. 5.2.15.3, p. 234)**
Delete marks in the animated model.

Settings (see chap. 5.2.15.3, p. 234)

Change the animation speed and turn the execution time on or off.

5.2.15.1 Process animation

This function manually creates process animation. It can be saved in XML files.

ATTENTION: The animation always occurs in the currently active model. The animation may not begin if the model of the other type is opened in the background.

Starting the process animation:

To start the animation, select the item "**process animation**" from the "**process stepper**" menu. It will be executed in a step-by-step manner beginning from the process start object.

Hint: While the stepper flows, the objects on the drawing area will be highlighted (one after the other).

Once the stepper encounters the decision a selection window appears, where you can choose further stepper path:

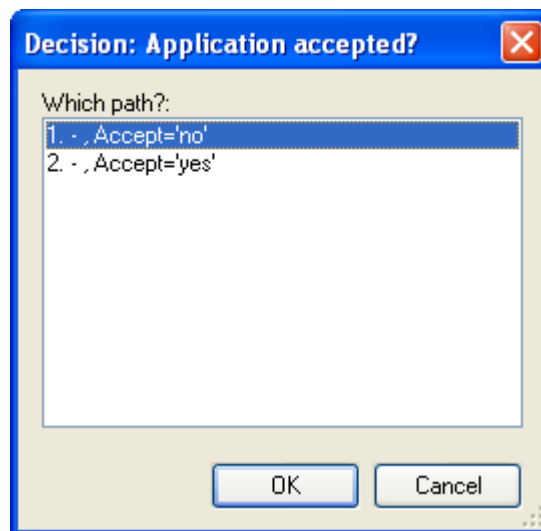

Figure 35: Process stepper - decision

Select further path and click "**OK**". If the stepper encounters a subprocess, there is a possibility to link an animation to this subprocess or to continue without it:

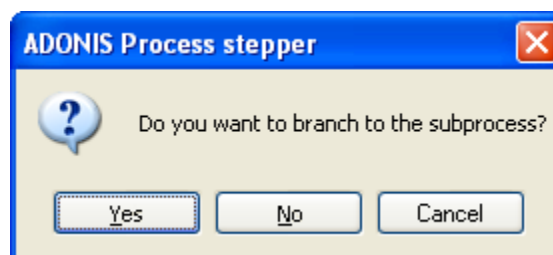

Figure 36: Process stepper - subprocess

If you want a subprocess to be part of animation click "**yes**", otherwise click "**no**".

Saving process animations:

At the end of an animation, the results dialogue will be displayed. It will show the execution time of the process and there is also the possibility to save the result of the animation::

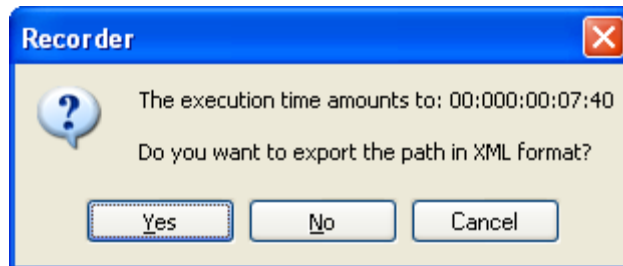

Figure 37: Process stepper - result

Click on **"yes"**, to save the animation. Otherwise click on **"no"** or **"cancel"**. The result will be deleted and stepper will stop.

5.2.15.2 Play back process animation

It is possible to load and play the saved animation at anytime. The exact process flow will be reconstructed as it was recorded. However, there is a difference - by playback, the execution time considered for calculation will be taken from the saved models (i.e. changes after saving the animation will not apply).

Launching the process animation :

Select the option **"playback process animation"** from the **"process stepper"** menu. A dialogue will be displayed, where you can choose the desirable animation file (*.step.xml format). After selection, the stepper will be executed with the model that is necessary for animation.

While the animation flows, the individual steps are displayed as it was saved in the animation file. At the same time, the actual execution time is calculated. At the end, an information dialogue with the actual execution time is shown:

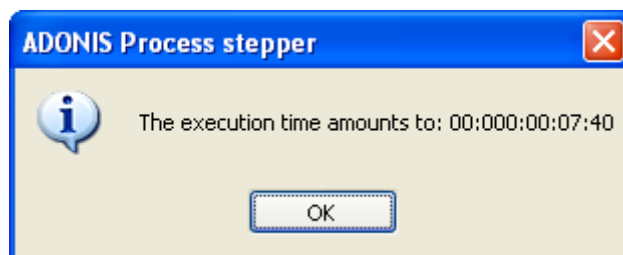

Figure 38: The result

5.2.15.3 Additional functions

Besides recording and playback other functions are available:

Remove marking of objects:

Select the option "**Remove marking of objects**" from the "**Process Stepper**" menu to hide marked process path and re-set to a standard view. The marks will then be hidden.

Hint: Closing models or starting a new animation will automatically remove markings.

Settings:

With the use of settings you can adjust the process steppers to fit your needs. To do so, select the "**setting**" option from "**process stepper**" menu and the following dialogue appears:

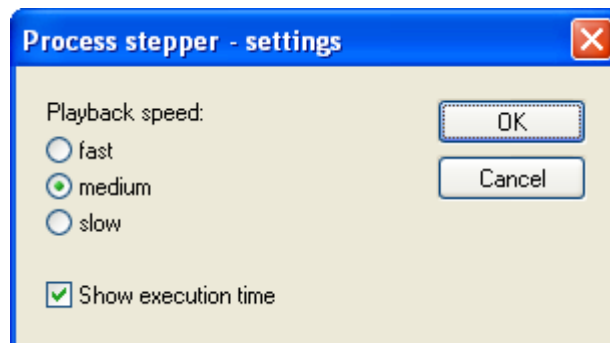

Figure 39: Process stepper - settings

By clicking on the appropriate radio button, you can set a desirable animation **speed**.

Hint: At the first time, the speed of process stepper is set to "medium". After this it will run with the most recently selected speed.

Generally, the process animation will be recorded to show the execution time for a specific path. If necessary, deactivate the option "**display execution times**" to hide the display of execution times.

Hint: With the same function, you can activate the display of execution time.

5.3 Simulation component

The simulation component contains the following library specific functions:

- Activation of manual random generator (see chap. 5.3.1, p. 235)
- Activation of automatic random generator (see chap. 5.3.2, p. 236)

5.3.1 Activation of manual random generator

A manual random generator can be activated in the simulation component. To activate it, select the "**Edit**" menu, its submenu **Random generator** and then click on the menu point **Activate manual random generator**.

The "Activate manual random generator - model selection" window (see fig. 40) will be displayed, in which you can select models that should be used for the generation.

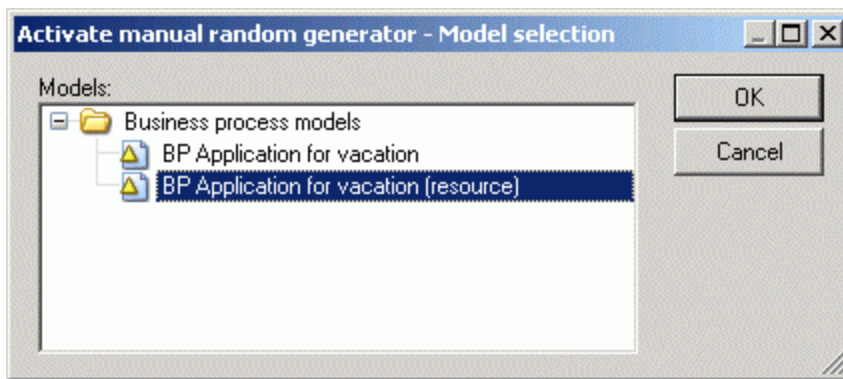

Figure 40: Selection of models for manual variable assignment

Hint: Only open models with write access are available for selection!

The activation of a manual random generator will be confirmed by an appropriate message window.

All "Manual random generator" attributes in the "random generator" objects of the selected model will be occupied with value "yes" (the representation occurs through a checkmark in the notebook). On the drawing area a hand symbol will appear next to objects.

The user can decide whether to activate manual random generator, by selecting the value of the random generator during the simulation.

5.3.2 Activation of automatic random generator

An automatic random generator can be activated in the simulation component. For activation click on the "Edit" menu and then select the "Random generator" submenu and choose the menu point "Activate automatic random generator".

The "Activate automatic random generator - model selection" window will be displayed (see fig. 41), in which you can select the models that should be used for the generation.

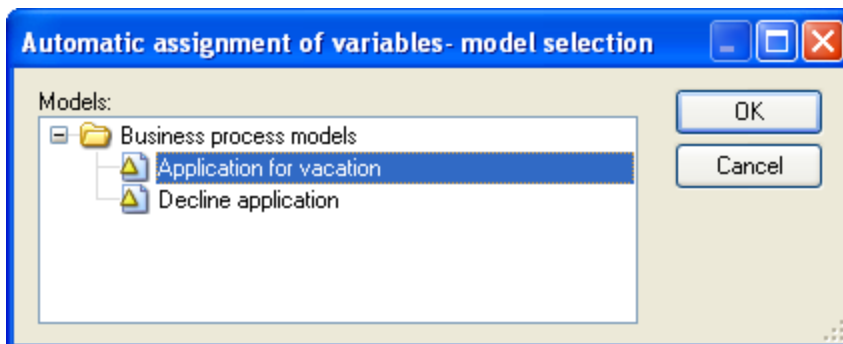

Figure 41: Selection of models for automatic random generator

Deactivation of the manual random generator will be confirmed by an appropriate message window.

All "Manual random generator" attributes in "random generator" objects of the selected model will be occupied with value "no".

If the automatic random generator is activated, the value of the random generator will be assigned automatically during the simulation.

5.4 Evaluation component

The evaluation component contains the library specific function "monitoring" (see chap. 5.4.1, p. 237).

5.4.1 Monitoring

5.4.1.1 Initialise current values

During the initialisation the current value will be created in rows and columns of the performance indicator's table target value in the selected models depending on the performance indicator's selected period. References in the "Performance indicator overview" table will determine what ratio should be initialised.

Hint: Take into consideration the requirements for current value initiation (see p. 237).

The current value initialisation is carried out as follows:

1. Select the "initialise current values" from the "monitoring" menu that is located in the evaluation component.
2. Select the model or models and click on the "initialisation" button.

Note: If there is not exactly one object of the class "performance indicator overview" per model, then an appropriate message window is displayed and initialisation cannot be performed.

Note: If no planning period is defined, the initialisation can be interrupted.

After initialisation, the rows of the referenced performance indicator (defined period) will be initialised.

The Calculate current values (see chap. 5.4.1.2, p. 238) is now possible.

Requirements for current value initialisation

1. Define the performance indicators in the Business Process Model.
2. Arrange the periods for the performance indicators.

The following periods are available:

- Day
- Week
- Month
- Quarter
- Half year
- Year

3. Define exactly one object of the class "performance indicators overview" per model.
4. Define references on the performance indicator, that are in the "performance indicators overview" table in the "performance indicator" chapter.

From the model initialisation, only those performance indicators that have defined references in the table 'performance indicator overview' will be initiated. In this manner, selective initialisations and the actualisations can be carried out.

5. Establish the period configuration in the object "performance indicator overview".

The settings in the chapter "period configuration" influence current value initialisation.

5.4.1.2 Calculate current values

After the successful initialisation of current values (see chap. 5.4.1.1, p. 237), it is possible to calculate the current value.

There are three calculation options:

- manual coupling
- excel coupling
- database coupling

Independently from the data source that will be used for calculation of performance indicators the actualisation will be carried out as follows:

1. Select the "calculate current values" from the monitoring menu that is located in the evaluation component.
2. Select the model with the actualised performance indicators.

Option "show warnings": Warnings encountered during actualisation can be shown or can remain hidden.

Option "use system date": If this attribute is selected, the actualisation is made with use of system dates. If you want to use a different date for actualisation, activate the actualisation button and select the date through the date dialogue:

3. Data selection through the data dialogue.

Hint: If there is more than one object of the class "performance indicator overview" per model, a message will be displayed.

Hint: If the selected data is out of the defined planning period (for the actualisation), the performance indicators of respective models will not be actualised and a corresponding message will be displayed.

An appropriate message will be displayed after the calculation of current values;

5.5 Import-/Export-Component

The import/export component contains the following library specific functions:

- HTML-Generation (see chap. 5.5.1, p. 238)
- Word-Generation (see chap. 5.5.2, p. 240)
- Settings (see chap. 5.5.3, p. 242) for documentation generation
- Attribute and class filter (see chap. 5.5.4, p. 247) for documentation generation
- Corporate Identity (CI) (see chap. 5.5.5, p. 249)

5.5.1 HTML generation

Start the HTML generation by choosing from the menu "**Documentation**" menu option "**HTML generation**" or by clicking the smart icon  from the quick access bar.

In the window "ADONIS BPMS modelling method - HTML settings" (see fig. 42) the **language** or **corporate identity schema** (see chap. 5.5.5, p. 249) for the generated documentation can be chosen.

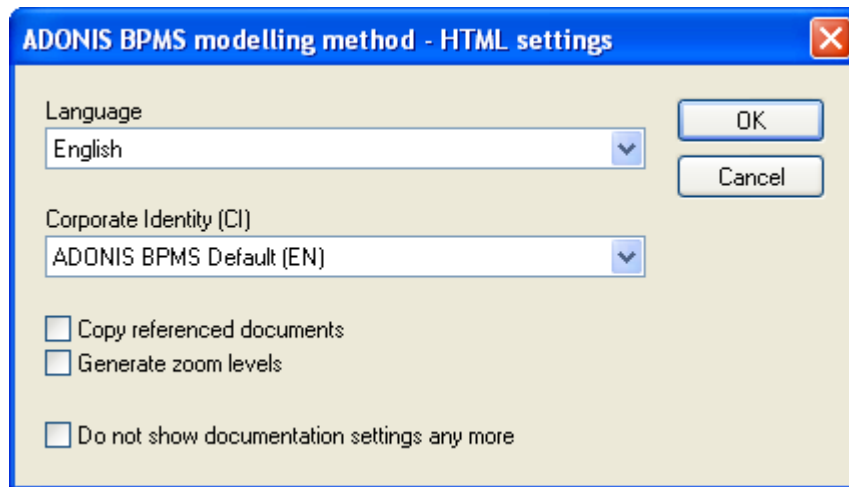

Figure 42: Settings for the HTML generation

If the option "**Copy referenced documents**" is chosen, all files referenced in the ADONIS models will be copied into the target HTML directory. If the option "**Generate zoom levels**" is selected, ADONIS models will be generated in several sizes (zoom levels).

Activating the option "**Do not show documentation settings any more**" means that during the next HTML generation this window will not appear and the current settings will be used.

Click on the OK button to continue the HTML generation.

In window "HTML generation" (see fig. 43) select the models to be included in the documentation.

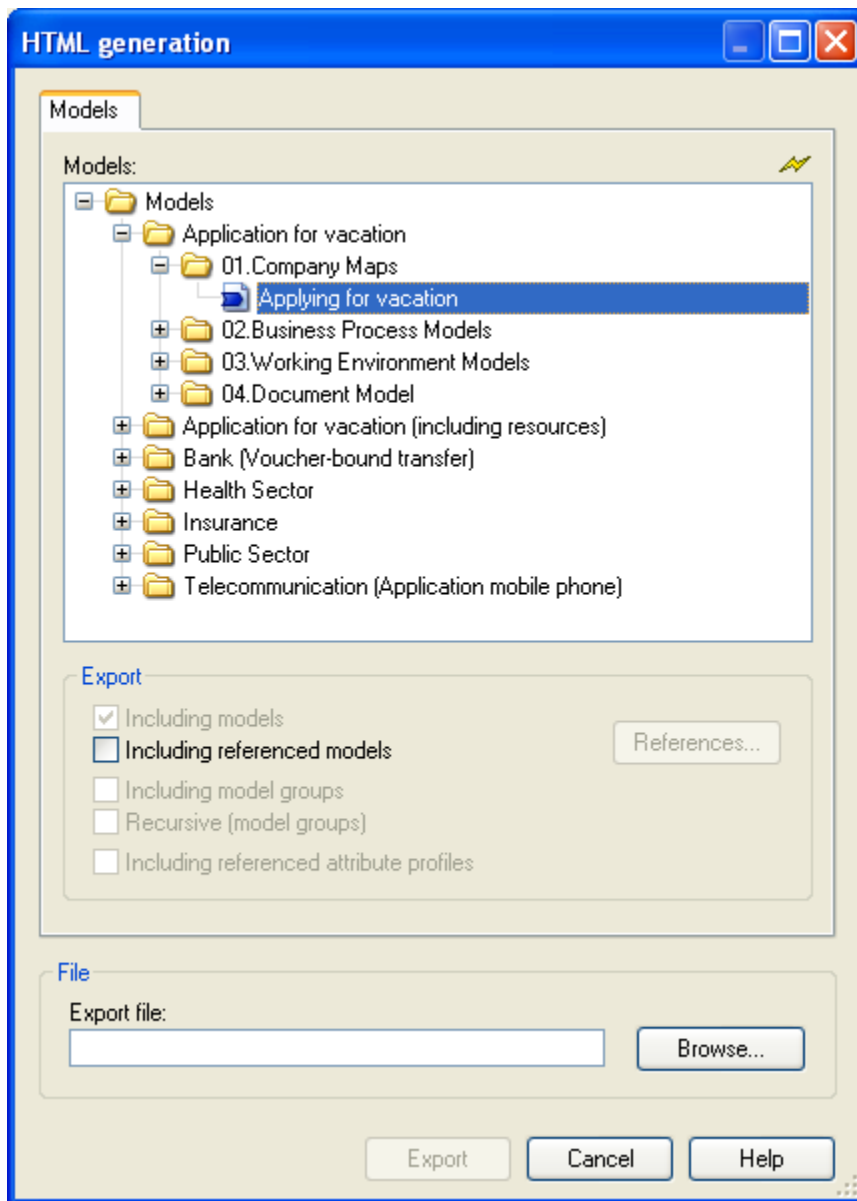

Figure 43: Model selection for the HTML generation

Activate the option **"Including referenced models"** if all of the selected models as well as their referenced models should be contained in the documentation. Click the **"References"** button to change the settings.

Enter into the field **"Export file"** the path and file name where the documentation of the selected models should be generated. Click the OK button to start the HTML generation process with current settings (see chap. 5.5.3, p. 242).

After successful generation, an information window will appear and the HTML documentation will be available in the selected folder.

5.5.2 Word generation

Hint: It is advisable to number (see chap. 5.2.4, p. 222) objects prior to the Word generation (relevant to company maps, Business Process Models and Working Environment models) because objects descriptions are generated according to the sequence of numbers

and therefore the documentation is easier to read (especially in the Business Process Models).

Start a generation of Word documents by choosing from the menu **"Documentation"** menu option **"Word generation"** or by clicking the smart icon  from the quick access bar.

In the window "ADONIS BPMS modelling method - Word settings" (see fig. 44), **the language** or **corporate identity schema** (see chap. 5.5.5, p. 249) for the generated documentation can be chosen.

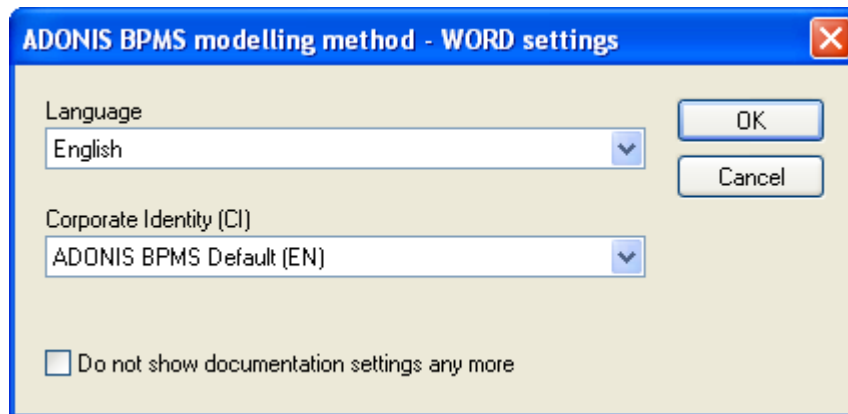

Figure 44: Settings for Word generation

Activating the option **"Do not show documentation settings any more"** means that during the next Word generation this window will not appear and the current settings will be used.

Click on the OK button to continue with the Word generation.

In the window "Word generation" (see fig. 45) select the models to be included in the documentation.

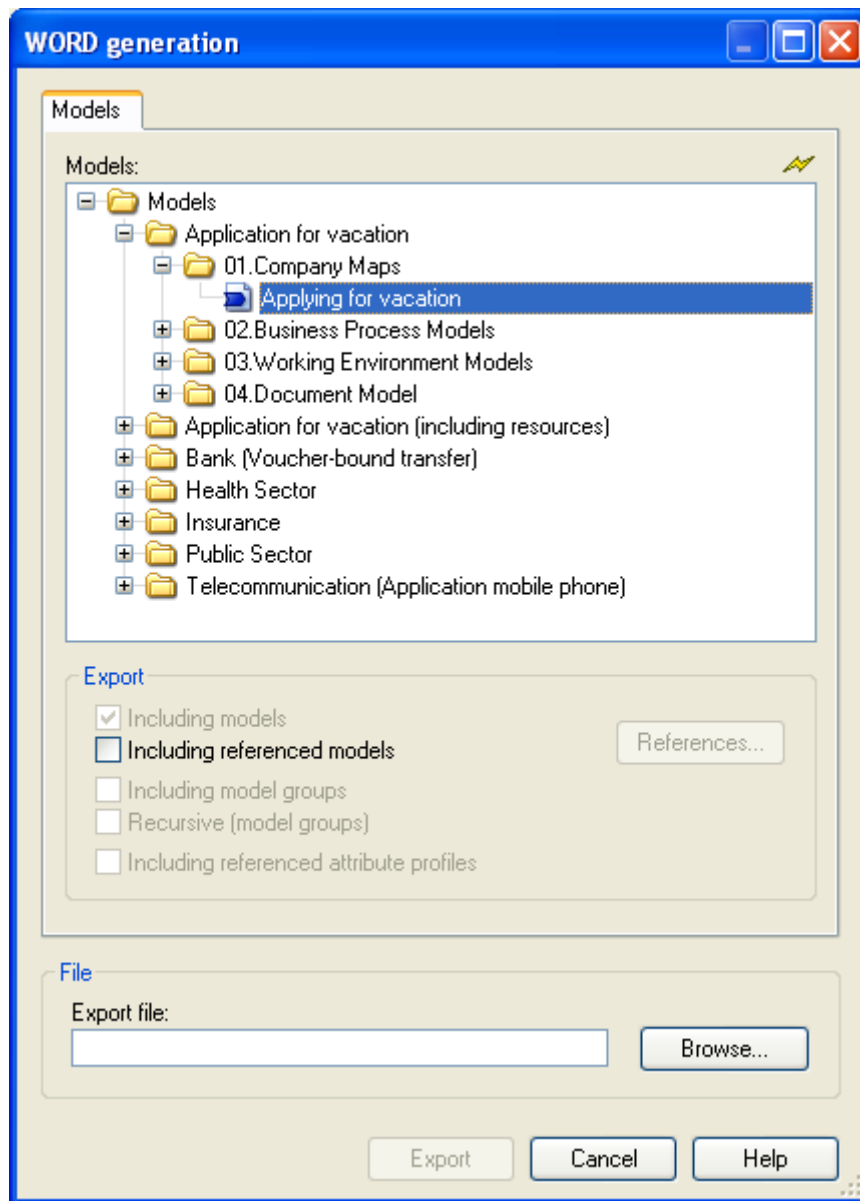

Figure 45: Model selection for the Word generation

Activate the option **"Including referenced models"** if all of the selected models as well as their referenced models should be contained in the documentation. Click the **"References"** button to change the settings.

Enter the path and file name, where the documentation of the selected models should be generated, into the field **"Export file"**. Click the OK button to start the Word generation process with the current settings (see chap. 5.5.3, p. 242).

After successful generation an information window will appear and the Word documentation will be available in the selected folder.

5.5.3 Options (Documentation)

To open the ADONIS notebook for documentation settings, select the "Options" menu point from the "Documentation" menu (see fig. 46).

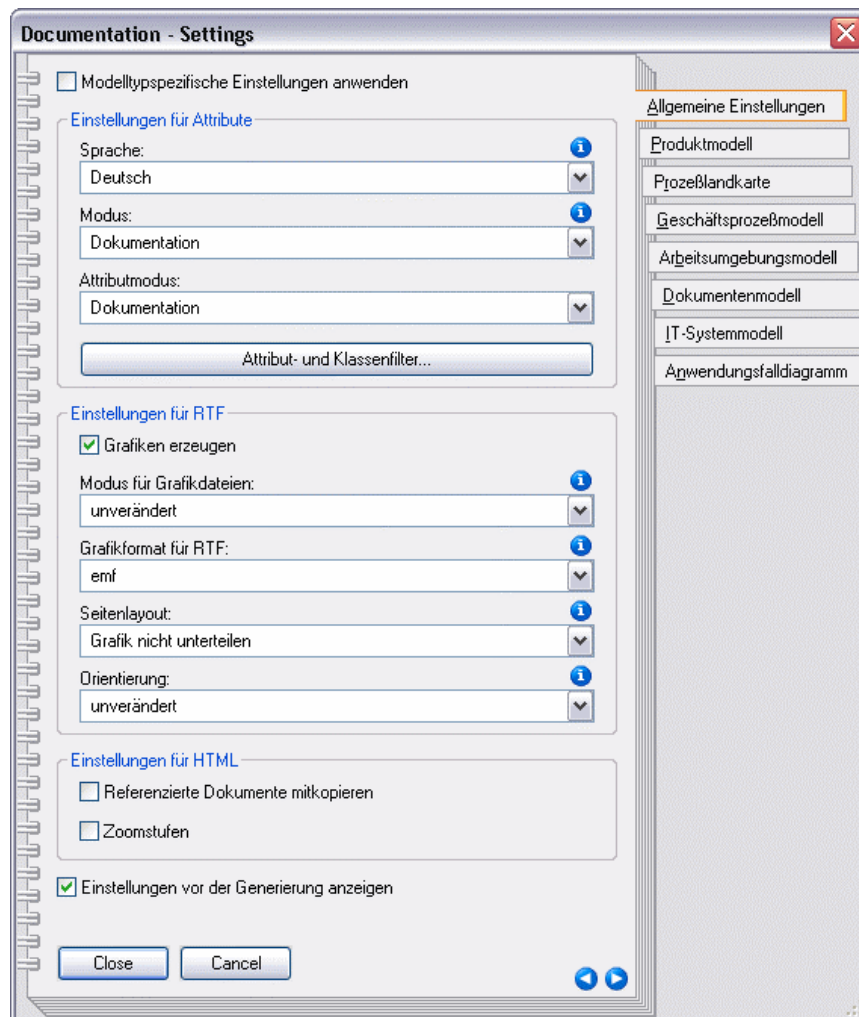

Figure 46: Documentation settings of the ADONIS BPMS application library

Next to the "general settings" chapter, there are additional chapters for each model type.

Hint: Options "mode", "attribute mode", mode for "graphic file mode", "orientation", "page layout" and "graphic generation" are available in every notebook chapter..

While using the ADONIS BPMS application library, you can carry out the following options:

General options:

Option "Apply model specific settings"

By default, the standard settings apply to all models, however it is possible to adjust the settings for the given model by clicking on the "apply model specific options" option. If this option is activated, the options from the corresponding chapter will be used during the generation of documents to the given model type.

Option "Language"

The language selected language does not have any influence on the graphical representation of exported models. To adjust the language to the graphical representation, select the "views" from the "view" menu and click on the "select the language for visualising attributes" menu point. Follow the further instructions.

Option "Copy referenced documents"

If you activate this option, documents referenced from the models will be copied into the sub-folder in the HTML documentation folder. All copied documents will be available for the HTML documentation users. It allows creating standalone HTML documentation..

General options / Model specific settings:

Mode

The documentation component supports the model view i.e. the result of a generation can be represented in a similar way to the models and modelling components through the view mode. By choosing a mode, only objects of the given modelling class, will be taken in the document generation.

Example:

In the working environment model, the "standard" mode will display objects of classes "organizational unit", "performer" and "role" whereas the "role diagram" mode limits objects representation to "performer" and "role" (see fig. 47). In "role diagram" options, only objects of classes "performer" and "role" and their attributes will be taken in the documents generation.

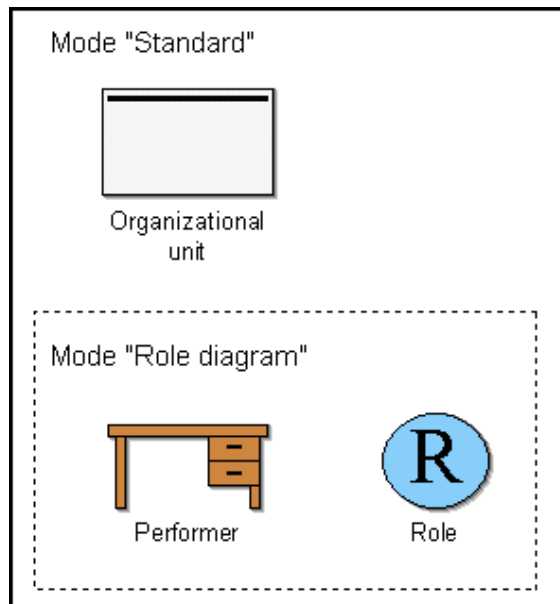

Figure 47: Modes in the Working Environment

Hint: The mode options only influence text representation of the model content. The model's graphical representation is handled by the option "Modes for graphics generation".

Attribute mode

An active attribute mode determines which object's attributes will be used in the document generation.

Example:

Objects of the "performer" class (see fig. 48) contains the following represented attributes. Attribute mode "Documentation" limits the output to attributes "name", "description" and "comment".

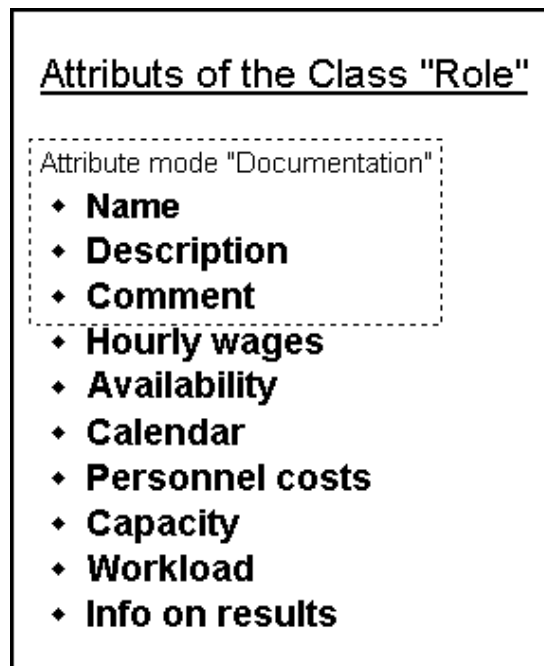

Figure 48: Attributes of the "performer class"

Attribute and class filter

Attribute and class filter (see chap. 5.5.4, p. 247) determines what information (classes, relations, and attributes) should be exported to the document generation.

Option "Create graphics"

If the document should not contain any graphics, deactivate this option. The document will be then generated without graphics and will not contain any references to the graphics.

Graphic format for Word

Here you can determine what file format should be used for Word generations. There are two file formats available: .emf (default) and .bmp.

Graphic format for HTML

Here you can determine what file format should be used for HTML generations. There are two file formats available: .png (default) and .jpg.

Graphic file mode

Documentation components support the model view in a similar way to modelling components through view modes. By choosing a mode, only objects of the given modelling class will be included in the model graphics generation.

Hint: In contrast to view modes in the modelling of a single model, chosen settings will apply to all models of the given type.

The selected graphic file mode does not affect the view mode for modelling.

Example:

In working environment model, mode "standard" will display objects of classes "organizational unit", "performer" and "role" whereas mode "role diagram" limits objects representation to "performer" and "role" (see fig. 47). In "role diagram" options, only objects of classes "performer" and "role" and their attributes will be taken in the documents generation.

Hint: The "Graphic file mode" option influences only the graphical representation of the model content. The text representation of the model is controlled by the option "Modes".

Orientation

Graphic files can be generated without rotation, rotation by 90° (left or right), or rotation by 180° (upside down). Select and adapt the orientation of the graphic files (layout) to the page layout

Part III

setting. **Note:** The option "orientation" has an effect exclusively on the Word generation. The model graphics in the HTML documentation will always remain unchanged.

Example:

Following figure (see fig. 49) illustrates an example of the graphics orientation in the document. Word document on the left side contains unchanged graphics. On right side, Word document has graphics rotated by 90° (counter clockwise direction). Rotated graphics is displayed in a bigger format and therefore is easier to read.

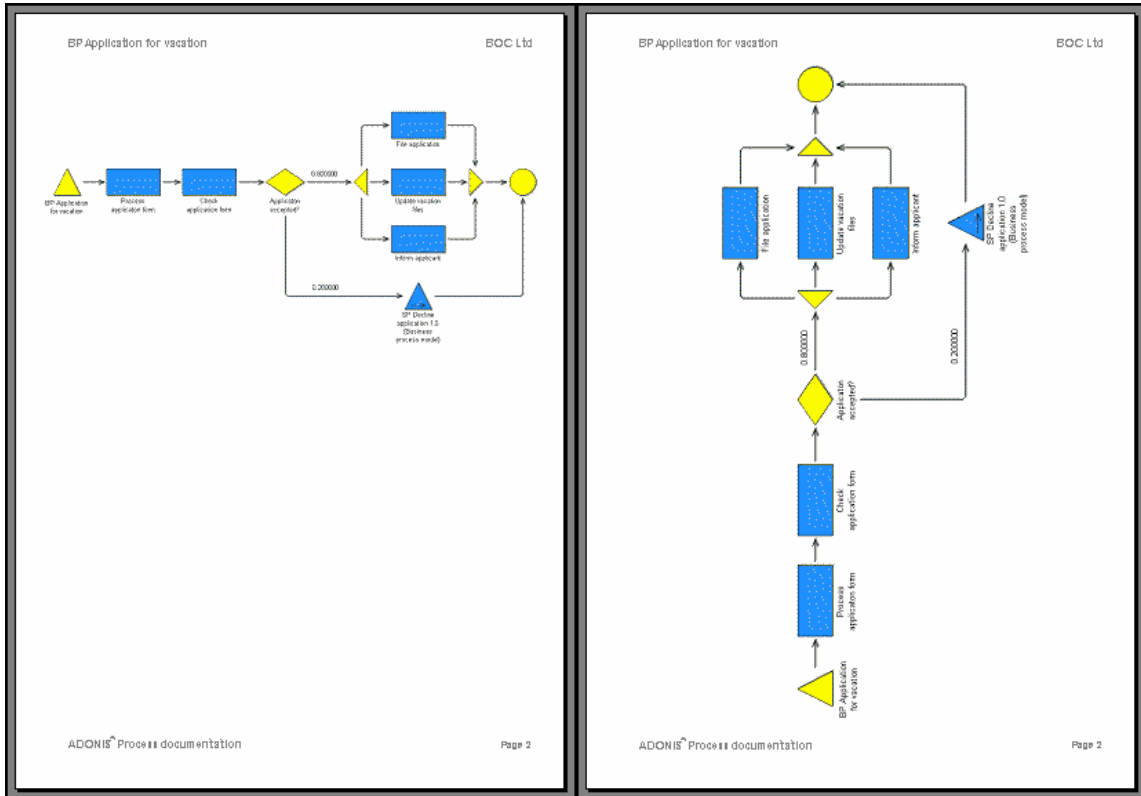

Figure 49: Example of Word generation (unchanged - left side, rotated by 90° - right side)

Page layout

Select this option to adjust the page layout for graphics to be generated.

ATTENTION: In this section, selected page layouts refer exclusively to graphics of the generated models, not on the documentation's page layout itself.

Note: The option "page layout" has an effect exclusively on the Word generation. The model graphics in the HTML documentation will always remain unchanged.

Hint: Choosing the option "Apply layout settings from model" causes that scale factor, direction and page borders to be inherited directly from the model.

Example:

The following figure (see fig. 50) illustrates an example of the graphic's page layout in the documentation. The Word document is generated with the BPMS ADONIS page layout settings, whereby the graphics size is set to fit on two pages.

Hint: Connector marks that were represented on the figure have to be explicitly created.

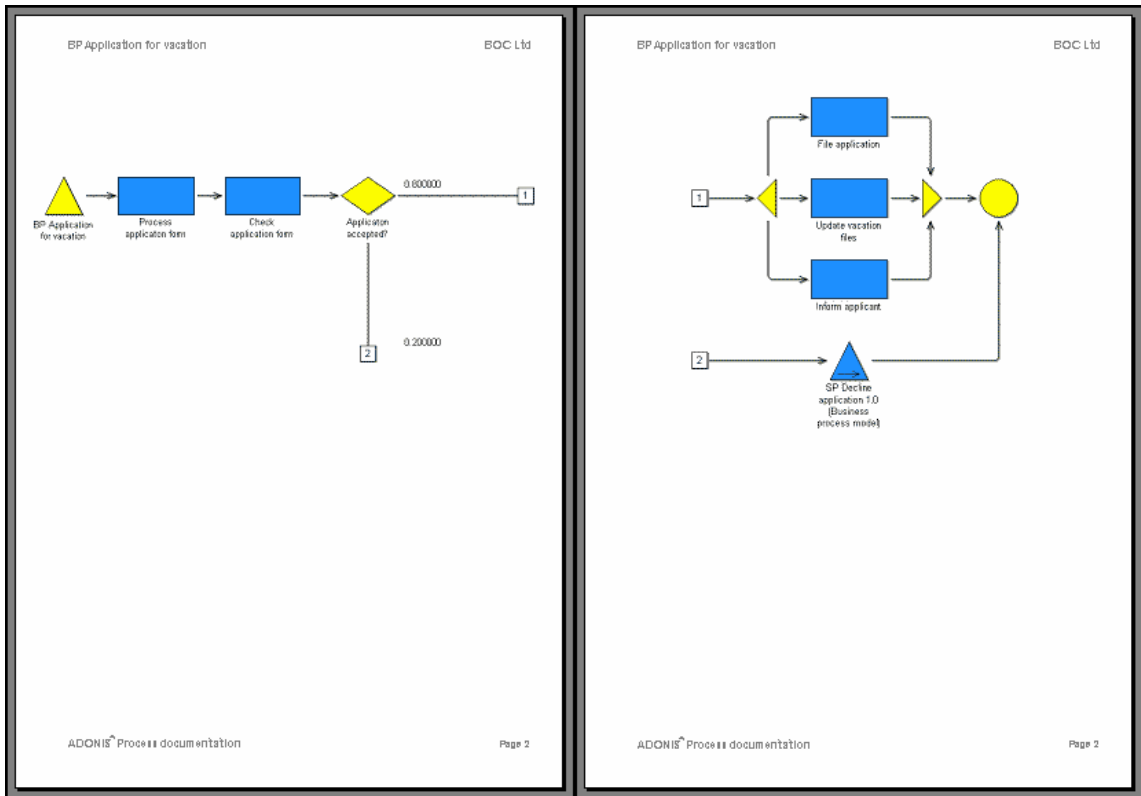

Figure 50: Example of Word generation with page layout settings

To save the current settings, click on the "close" button. If you click on "cancel" button, changes will not be saved.

5.5.4 Attribute and class filter

To edit settings for the document generation select the "attribute and class filter" menu point from "documentation".

In the window "Documentation - Attribute and class filter" (see fig. 51), you can select the information (classes, relations and attributes) that should be exported to the document generation.

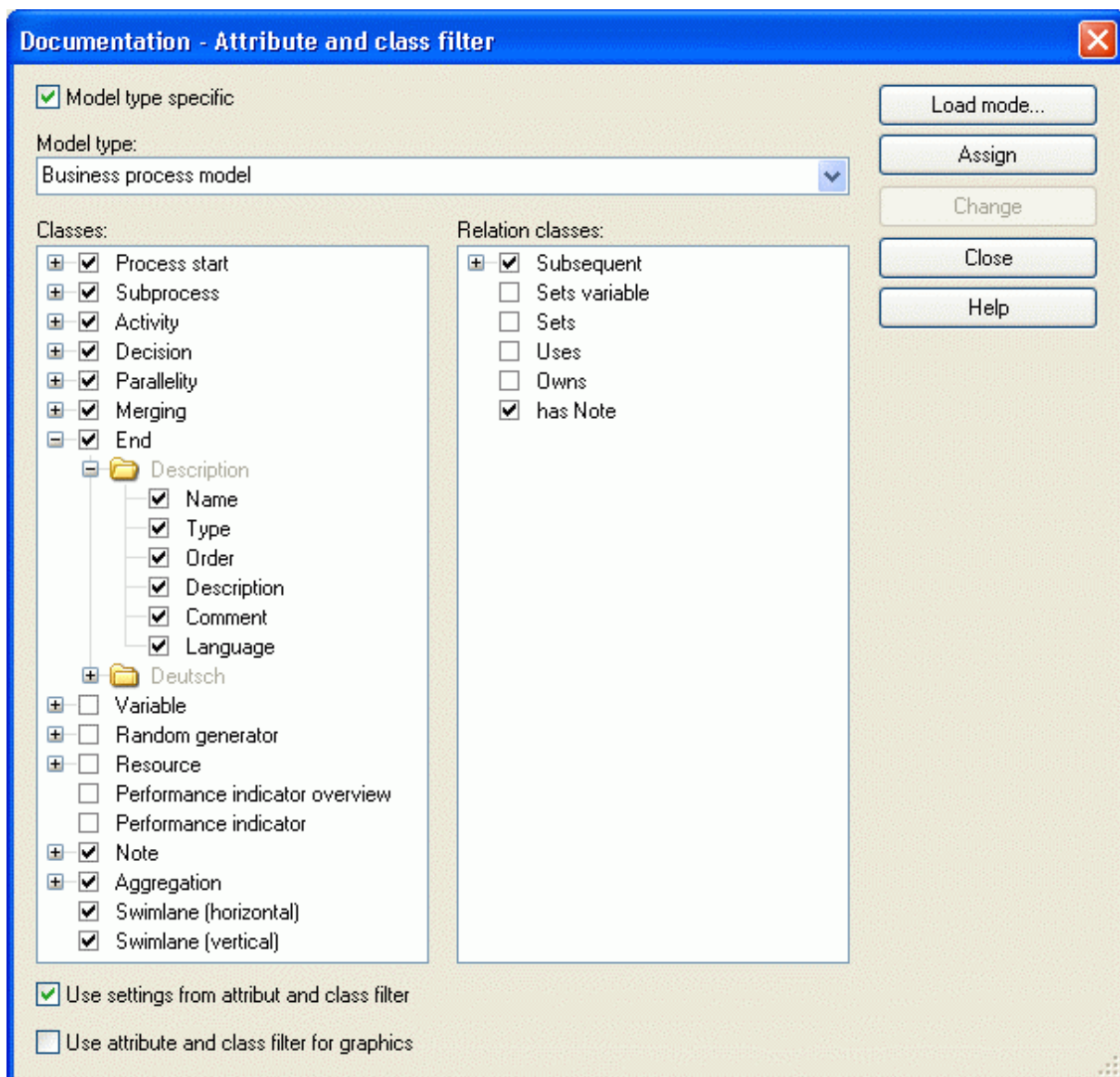

Figure 51: Attribute and class filter for the documentation (settings in the ADONIS BPMS application library)

Activate the box "**Model specific type**" if you want to define an individual criteria for each model type. Deactivate this option if the same rules should be applied for the whole library.

If the box is activated () , select every **model type**, for which you wish to set information for export.

Now, you see both lists - **classes** and **relations** with all selected objects and connectors.

The symbol in front of a class, relation or an attribute indicates that class, relation or attribute will be taken in the documentation. Classes, relations or other attributes that will not be exported to the documentation are marked with .

To deselect a particular class, relation or attribute click on the symbol (check mark will disappear) i.e. this particular element will not be taken in the documentation.

Click on the symbol (the check mark will appear), to select a particular class, relation or attribute i.e. this particular element will be taken in the documentation.

If you want to change several elements at once, select them and then click on the button "**change**". The status of all selected elements (either blank or marked) will change at the same time.

To activate or deactivate an individual object, click on the box, or select its name and then click on the **"change"** button.

To obtain a mode that is also available in the modelling component, click on the **"load mode"** button. A small dialogue window appears (see fig. 52), where you can set model type, mode and attribute mode. Modes that are displayed there, correspond to the view modes. As soon as you approve settings, the corresponding mode will be imported and applied. In terms of documentation it means that only the classes and relations, that are visible in the selected mode (in modelling component) and attributes that are visible in attribute mode will be also included in the generation.

The box **"use settings from attribute and class filter"** has to be activated if the selected settings have to be applied. Otherwise the selected options from the "Option - documentation" menu remain valid (see fig. 46).

Similarly, the box **"use attribute and class filter for graphics"** has to be activated in order to initiate settings for graphics.

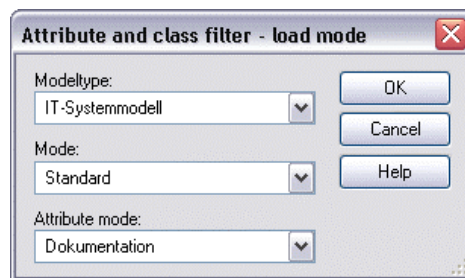

Figure 52: Attribute and class filter - loading mode

Click on the **"assign"** button, to save your settings and press **"Close"** to close the dialogue

5.5.5 Corporate Identity (CI)

For HTML or Word document generations customer specific Corporate Identity Schemas (CI Schema) can be defined and used.

This option allows using company logos as well as defined header or footer texts.

For administration of CI Schemas, the following functions are available (menu "Documentation", menu point "Corporate Identity (CI)"):

- Create CI** Design new CI Schema and define the CI elements.
- Delete CI** Delete existing CI Schema.
- Edit CI** Edit existing CI Schema
- Set Default CI** Select CI Schema to be used
- CI Export** Export existing CI Schemas
- CI Import** Import existing CI Schemas

6. Expressions

In the ADONIS-BPMS-Application library 3.9 the following attributes of "expression" type are defined:

-  **Activity (see chap. 2.7, p. 57)**
 - Performer

The value of the attribute "performer" is calculated on the basis of the attribute "responsible role" in the notebook of the "activity" class. From the content of this attribute, a valid AQL expression will be created in the attribute "performer". Alternatively, the value can be defined by the ADONIS-user.
-  **Process (see chap. 2.15, p. 90)**
 - Estimated execution time
 - Estimated cycle time
 - Estimated costs
 - Estimated resting time
 - Estimated personal costs
 - Estimated transport time
 - Estimated waiting time

The value of this attribute is calculated on the basis of simulation results that were entered into the process start object of referenced Business Process Model. If the other model type is referenced, those attributes are empty. The ADONIS user cannot change the values entered.
-  **Subprocess (see chap. 2.6, p. 51)**
 - Performer

While switching between classes "Activity" and "Sub process" the values of the "activity" class attribute are taken over. Alternatively, the value can also be defined by the ADONIS-user.
 - Estimated execution time
 - Estimated cycle time
 - Estimated costs
 - Estimated resting time
 - Estimated personal costs
 - Estimated transport time
 - Estimated waiting time

The value of this attribute is calculated on the basis of simulation results that were entered into the process start object of a referenced Business Process Model. The ADONIS user cannot change the values entered.
-  **>Process start (see chap. 2.5, p. 44)**
 - Quantity

There is no expression defined. ADONIS users can decide what value to enter.
-  **Resource (see chap. 2.14, p. 87)**

- Selection

There is no expression defined. ADONIS user can decide by itself what value to enter.

- **Performer (see chap. 2.32, p. 151)**

- Availability

The value of this attribute is calculated from values of attributes: "Days per week" and "Hours per day". The number of week hours is set to 40 (=100 percent).

7. Attribute profiles

Attribute profiles are used for the central management of common attributes that can be referenced in the notebook.

In objects of "Performer" (working environment model) (see chap. 2.32, p. 151) references can be created in the attribute "presence" in the attribute profile of the "**presence**" class. The attribute profile class "presence" contains the attributes "days per week" and "hours per day" (see fig. 53). The work time of the particular performer can be set by reference to the corresponding attribute profile.

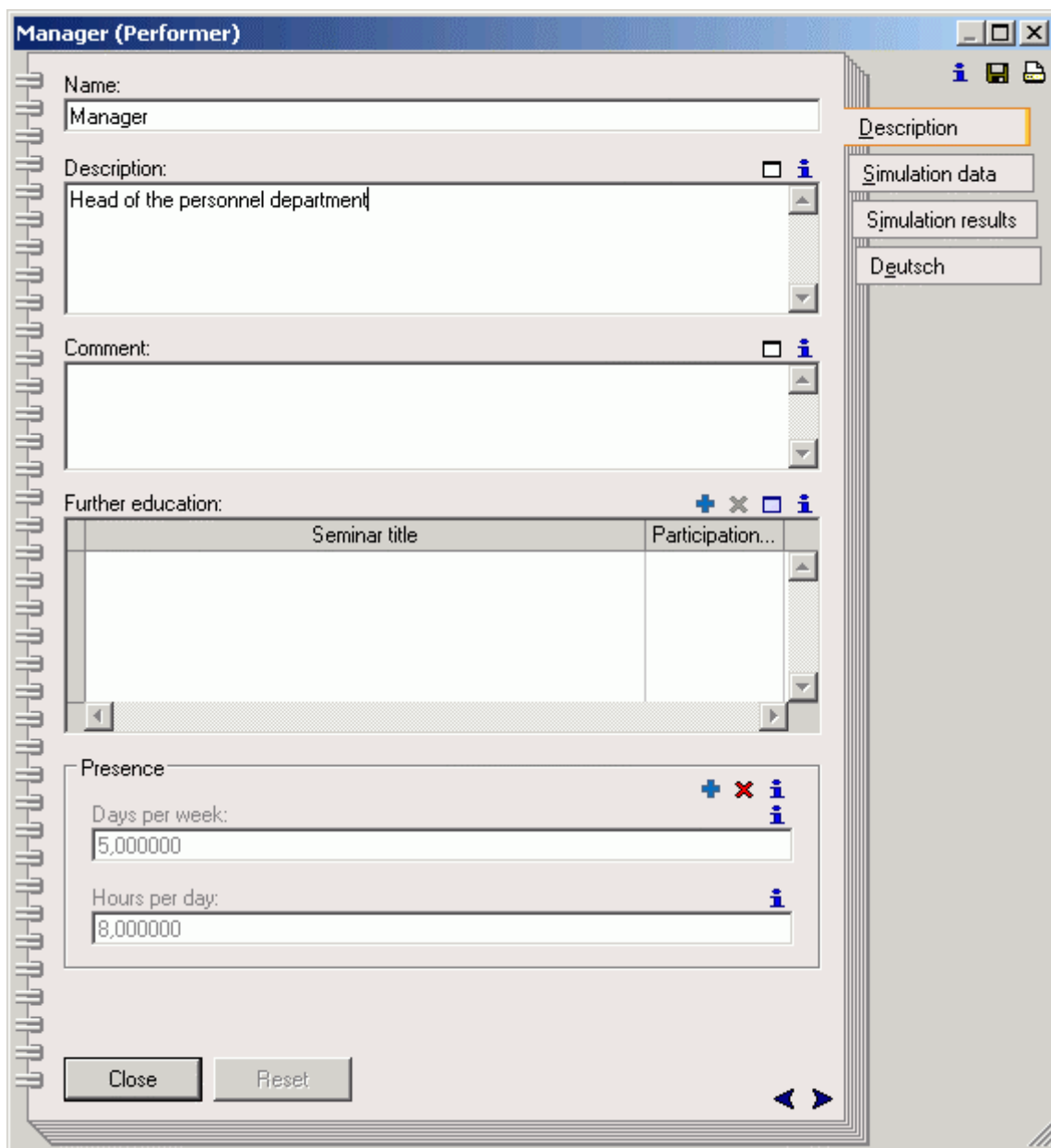



Figure 53: A window "editing attribute profile"

To assign the attribute profile to a performer, open the performer's notebook and click on the "add" icon  in the "presence" section. The window "Adonis-BPMS-application library 3.9 attribute profile selection" will be displayed (see fig. 54).

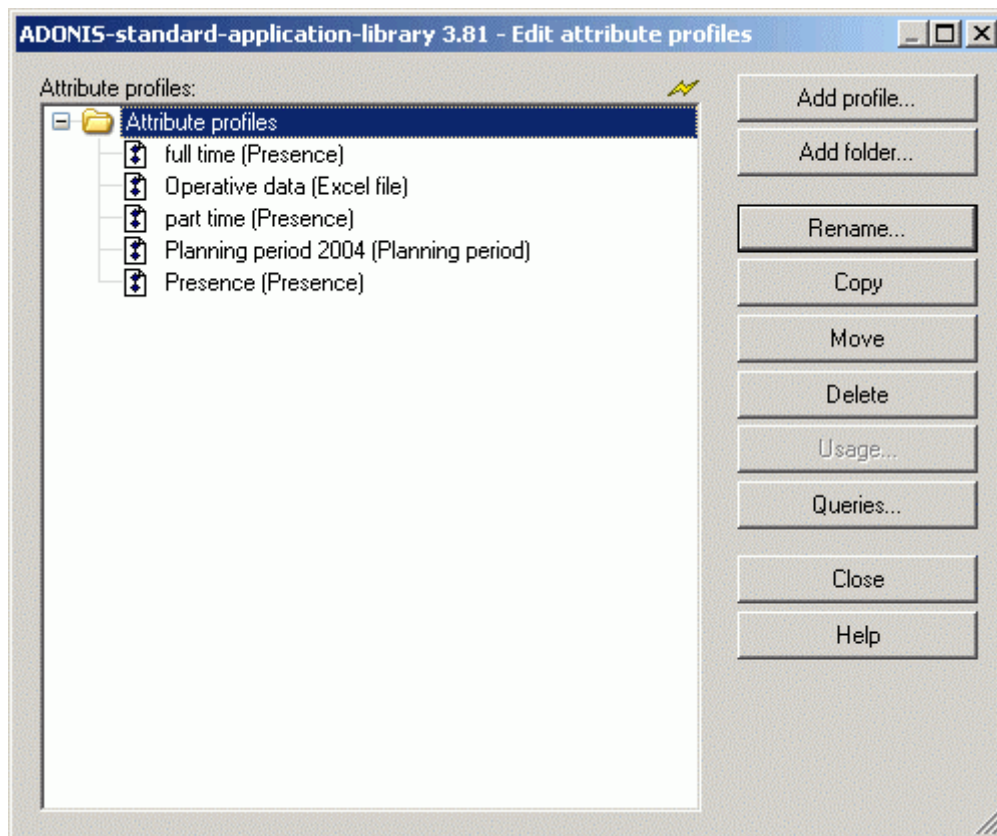



Figure 54: A window "attribute profile selection"

Select one of the existing profiles from the list or create a new one by clicking on the "add profile" button.

Hint: Only user with special rights can create a new attribute profiles. If you do not have those rights, there will be no "new attribute profile" button in the window "ADONIS BPMS application library 3.81 - attribute profile selection". If necessary, contact your ADONIS administrator.

After selection of the desired attribute profile click on the "assign" button to assign selected profile to the performer. Attributes "days per week" (by default 5, if no attribute profile will be referenced) and "hours per day" (by default 8, if no attribute profile will be referenced) of assigned attribute profile will be displayed in the notebook

To delete the reference of attribute profile, click on the "delete" icon in the presence section .

8. Tables

Tables are located in the Business Process Model "process start" class (see chap. 2.5, p. 44) and in the Working Environment "performer" class (see chap. 2.32, p. 151). They are centrally managed and assigned to the notebook.

	Seminar title	Participation in
1	ADONIS 1a - Process Modeller	03.2004
2	ADONIS 1b - Process Modeller Expert	03.2004
3	ADONIS 2a - Process Manager	03.2004
4	ADONIS 3a - Administrator	05.2004

Figure 55: An example of a table in the "performer" class

To **add a row**, open the notebook and click on the **"add"** button above the particular attribute (+).

To **delete a row**, open the notebook, click on the particular row number and then the **"delete"** button (X).

To **see the entire content** of the table, open the particular notebook and click on the icon "window" that is above particular attribute (□).

In a "dialogue" window there is an option, to save a table for printing purposes or search for browser contents.

	Seminar title	Participatio...
1	ADONIS 1a - Process Modeller	03.2004
2	ADONIS 1b - Process Modeller Expert	03.2004
3	ADONIS 2a - Process Manager	03.2004
4	ADONIS 3a - Administrator	05.2004

Buttons: Save... Print... Search... Close Help

Figure 56: Table - "dialogue" (example)

9. Example models

During the installation of the ADONIS Business Process Management toolkit, the following ADL files will be copied in the \examples subfolder of the ADONIS installation folder

- Example-General.adl (see chap. 9.1, p. 255)
- Example-General_incl_resources.adl (see chap. 9.2, p. 262)
- Example-Assurance.adl (see chap. 9.3, p. 267)
- Example-Bank.adl (see chap. 9.4, p. 279)
- Example-Health.adl (see chap. 9.5, p. 280)
- Example-PublicServices.adl (see chap. 9.6, p. 281)
- Example-Telecommunication.adl (see chap. 9.7, p. 282)

The files above contain exemplary models of the ADONIS BPMS application library that can be imported to ADONIS.

When models are described in this document, some details are omitted to improve clarity. More detailed information about the business process management toolkit can be found in the ADONIS user manual.

9.1 Models of the file Example-General.adl

The file Example - General.adl consists of

Company map

- **"Applying for vacation"** (see chap. 9.1.2, p. 256),

Business Process Models

- **"Application for vacation"** (see chap. 9.1.2.3, p. 258) and
- **"Decline application"** (see chap. 9.1.2.4, p. 261)

Working Environment model

- **"Application department"** (see chap. 9.1.2.2, p. 257)

and Document model

- **"Document model (Application for vacation)"**.

Problem description (see chap. 9.1.1, p. 256) documents the organisation structure and a flow of business processes.

Defining an application model:

If you want to simulate models of the file "example-general", you have to define an application model before the execution of a "capacity analysis" or "workload analysis".

Application models consists of at least one Business Process Model

Part III

- "Application for vacation"

and the Working Environment model

- "Application department".

9.1.1 Problem description

An enterprise has an application department (named "Application department") with 5 workers. It employs a department manager, two specialists and two secretaries (remark: all of them belong to the same cost centre).

Each employee's vacation application goes to the personal department and is handled by one of the department workers. The department clerk passes an application to the department manager. The department manager checks the application and makes the decision upon approval (80% of applications will be approved).

If the application is approved, the department manager gives the application to the office. The office archives the application, updates the vacation file and informs the applicant about the decision.

If the vacation application is declined, it will be sent to the office and filed there. The applicant is informed about rejection.

9.1.2 Modelling in ADONIS

A solution to the problem description (see chap. 9.1.1, p. 256) also takes place in the working environment model "Application department" (see chap. 9.1.2.2, p. 257), where the personnel department "Department 5" will be modelled as in the business process models "Application for vacation" (see chap. 9.1.2.3, p. 258) (modelling the application flow) and "Decline application" (see chap. 9.1.2.4, p. 261) (modelling the rejection).

9.1.2.1 Company map "Applying for vacation"

The company map contains the process models in a hierarchical structure (see fig. 57).

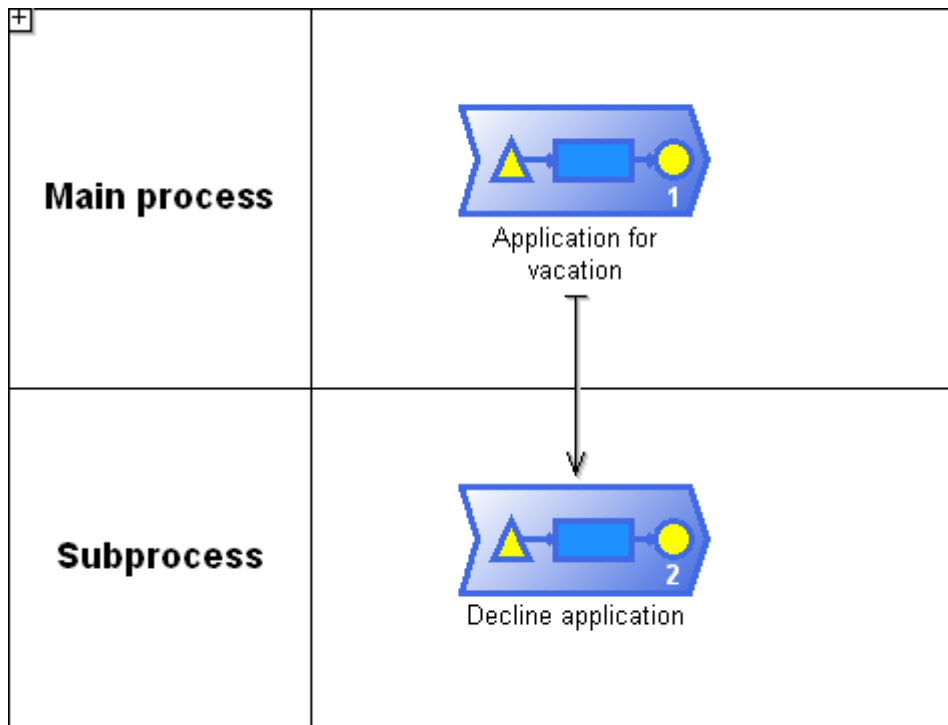

Figure 57: Company Map "Applying for vacation"

9.1.2.2 WE Model "Application department"

A description of the organisational structure is shown in the working environment model (see fig. 58).

☒

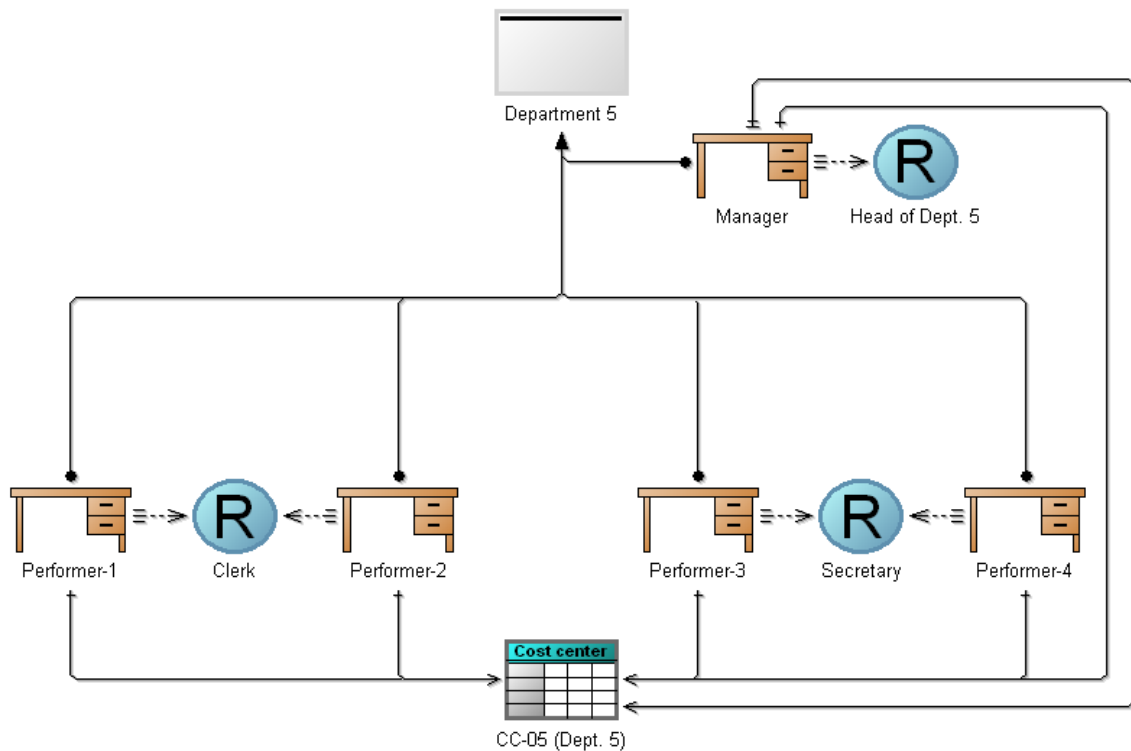

Figure 58: Working Environment model "Department 5"

Part III

The model contains an organisational unit with five performers. The organisational unit appears under the name "application department" and performers are anonymous: "manager", "performer-1", "performer-2", "performer-3" and "performer-4".

Performer duties are modelled as "roles". The performer "manager" is assigned to the role "head of department", "performer-1" and "performer-2" to the role "clerk", "performer-3" and "performer-4" to the role "secretary".

The relation "is manager" connects the performer "manager" to the organisational unit "department 5". The relation "belongs to" assigns all performers to the application department.

Hint: The relation "is manager" complements the relation "belongs to". It does *not* replace it.

Object's notebooks contain varied information. Next to described attributes, objects of the class "performer" contain simulation data. The following table (see fig. 59) presents the employee's hourly wages.

	Hourly wages
⊖ 1. Application department	
☞ Manager	100,00
☞ Performer-1	50,00
☞ Performer-2	50,00
☞ Performer-3	60,00
☞ Performer-4	70,00

Figure 59: Employee's hourly wages in the department 5

The performer's calendar shows the structure of a regular working week or absent time (weekend, holidays or vacation). This calendar information will be analysed by the workload simulation.

Hint: The performer's calendar is set with default values (working time: Monday - Friday, 9.00 - 12.00 and 12:30 - 16:30, free days and vacations etc. are not considered).

9.1.2.3 BP Model "Application for vacation"

Subprocess modelling takes place in the Business Process Model (see fig. 60).

Reference overview					
R	Clerk	Clerk	Secretary	Secretary	Clerk
A	Head of Dept. 5	Head of Dept. 5	Head of Dept. 5	Head of Dept. 5	Head of Dept. 5
C					
I					Secretary
In	Application for vacation	Application for vacation (processed)		Application for vacation (approved)	
Out	Application for vacation (processed)	Application for vacation (approved)	Application for...		

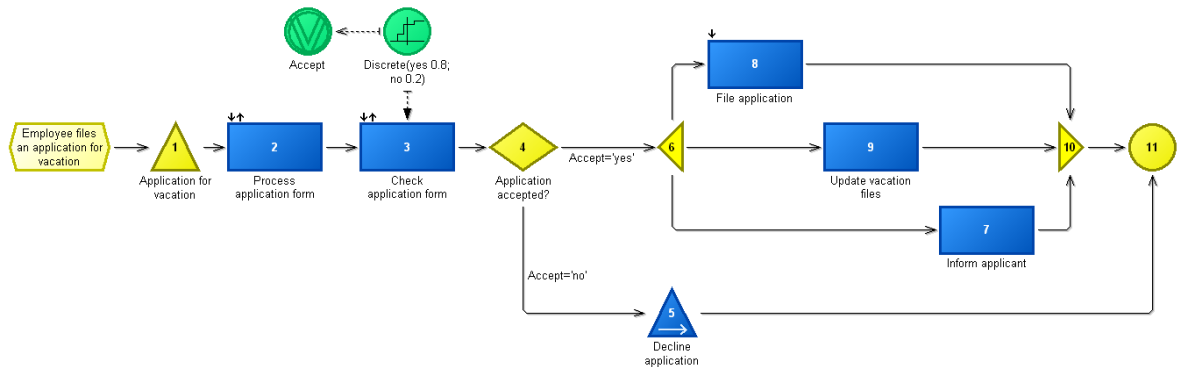

Figure 60: Business Process Model "application for vacation"

The process begins with class object "**process start**" named "application for vacation".

Next there are two objects of the class "**activity**": "process application form" and "check application form". The activity "process application form" is assigned to the performer with the role "Clerk" (i.e. performer-1 or performer-2), while the activity "check application form" has to be carried out by the "head of department 5".

After activities "process application form" and "check application form" the process branches out into two paths through the class object "decision" ("application accepted?").

● **Path 1:**

For application approvals, activities "update vacation files", "inform applicant", "file application" are carried out simultaneously (not sequentially). The parallelism will be symbolised by the class "parallelity", that has three outgoing branches to activities. The performer with the role "secretary" (i.e. performer-3 or performer - 4) carries out the three parallel activities. Parallel activities that are carried out by the same performer can only be completed in the sequential manner.

After parallel processes, the object of the class "**merge**" will merge the individual branches after the business process ends in the class object "end".

● **Path 2:**

The second path describes an application rejection. As written in the problem description, many business processes carry out declination of the applications in the identical form, independently from the business process "application for vacation".

Hence, "decline application" is modelled as the separated business process, to be used by different business processes.

For that purpose, an object of the class "subprocess" (with the name "decline application") will be modelled in the business process model "Application for vacation". The reference to the model "decline application" is set in the object's "decline application" notebook. The name of the referenced model is entered in the section "referenced process" (in this case it is "decline application" (see chap. 9.1.2.4, p. 261)).

Part III

After execution of the subprocess "decline application" (see chap. 9.1.2.4, p. 261), the main process will continue. The branch ends, because there are no further activities.

The logic flow - time and logic flow of the business processes, is represented by the relation "subsequent".

After the decision "application accepted?", both paths are required to define a "variable" to enable the simulation of the business process model "application for vacation" with the referenced subprocess "decline application". They are described with the name "accept".

The relation "sets variable" assigns the class object "random generator" to this variable.

The discrete distribution "Discrete (YES 0.8, NO 0.2)" (the attribute "value" in the class object "random generator") that is referenced to the object "application accepted?", is arranged in the transition condition of both relations "sets variable". Through this distribution, the object "acceptance" of the class "variable" is given the probabilities 0,8 for the value "yes" and 0,2 for the value "no".

The object of the class "random generator" is connected to the flow via the relation "sets". It has to be arranged **before** the object of the class "decision" (for example in the activity "check application form").

The flow conditions of the individual path are defined in the transition condition of the relation "subsequent", after the decision "application accepted?". In the transition condition of the acceptance proposal path the acceptance is set to yes (accept=yes). In the decline application path the acceptance is set to no (accept=no). The transition condition consists of the variable name "accept", the logical operator '=' and the constants from the object of the class "random generator" (YES or NO).

The objects notebook stores the information (attributes) such as the technical descriptions of activities.

The table below (see fig. 61) presents values of the attributes "execution time", "waiting time", "resting time", "transport time" and costs of all objects in the activity class. These attributes are required for simulation.

	Execution time	Waiting time	Resting time	Transport time	Costs
⊖ 1. BP Application for vacation					
■ Check application form	00:000:00:00:30	00:003:00:00:00	00:003:00:00:00	00:000:00:00:00	0,00
■ File application	00:000:00:01:00	00:000:00:00:00	00:000:00:00:00	00:000:01:00:00	6,00
■ Inform applicant	00:000:00:00:10	00:000:00:10:00	00:000:01:00:00	00:000:01:00:00	1,00
■ Process application form	00:000:00:01:00	00:000:00:00:00	00:000:00:00:00	00:000:00:00:00	0,00
■ Update vacation files	00:000:00:05:00	00:000:00:00:00	00:000:00:00:00	00:000:00:00:00	30,00

Figure 61: Simulation data of the activity in the business process model "application for vacation"

The attribute "performer" in the class object "activity" carries out the assignment to the performer from the organisational structure. Assignment of the performer is defined by AQL-query (AQL = **ADONIS Query Language**). ADONIS offers input supporting dialogs for entering data. The table below (see fig. 62) shows the performer assignment in objects of the class "activity" in the model "application for vacation".

	Performer
⊖ 1. BP Application for vacation	
■ Check application form	{{"Head of Dept. 5": "Role"} <- "Has role"}
■ File application	{{"Secretary": "Role"} <- "Has role"}
■ Inform applicant	{{"Secretary": "Role"} <- "Has role"}
■ Process application form	{{"Clerk": "Role"} <- "Has role"}
■ Update vacation files	{{"Secretary": "Role"} <- "Has role"}

Figure 62: Performer assignment in the business process model "application for vacation"

9.1.2.4 BP model "Decline application"

The subprocess "decline application" is modelled as a separate business process (see fig. 63).

Reference overview		
Ⓡ R	Clerk	Secretary
Ⓡ A	Head of Dept. 5	Head of Dept. 5
Ⓡ C		
Ⓡ I		Clerk
□ In		Application for vacation (declined)
□ Out		

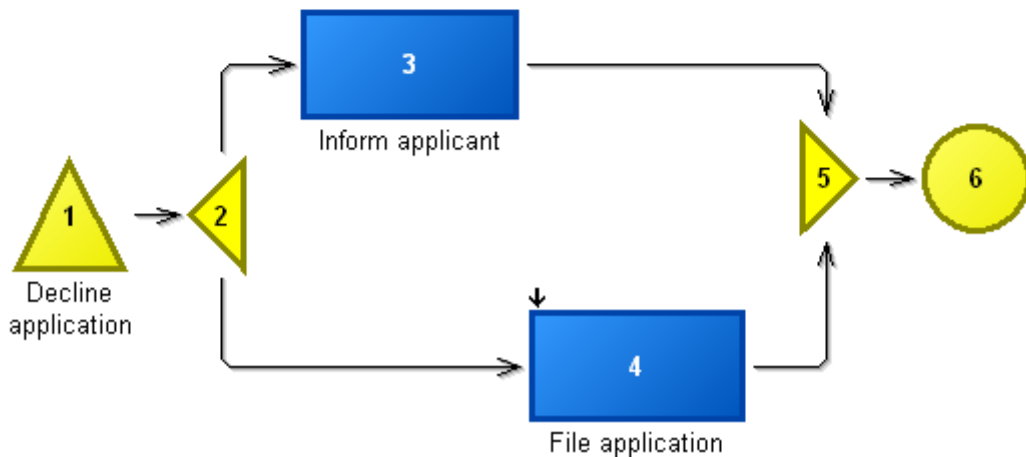

Figure 63: Business Process Model "decline application"

The flow within models starts from the object "decline application" of the class "process start". It follows the parallel activities "file application" and "inform applicant", which will be carried out by the performer with the role "secretary (i.e. performer-3 or performer-4).

Parallelism starts with the object of the class "parallelity" and ends with the object of the class "merge".

The business process ends after performing all parallel activities.

The logic is created by the connection of the illustrated objects via the relation "subsequent".

Part III

The notebook of objects "file application" and "inform applicant" contains the value of the attributes "execution time", "waiting time", "resting time", "transport time" and costs that are presented in the table below (see fig. 64).

	Execution time	Waiting time	Resting time	Transport time	Costs
⊖ 1. SP Decline application					
■ File application	00:000:00:05:00	00:000:01:00:00	00:000:00:00:00	00:000:01:00:00	30,00
■ Inform applicant	00:000:00:00:10	00:000:00:00:00	00:000:00:00:00	00:000:00:00:00	1,00

Figure 64: Simulation data of the activity in the business process model "decline application"

The attribute "performer" of the class object "activity" carries out the assignment of the performer from the organisational structure. Assignment of the performer is defined by AQL-query (AQL = ADONIS Query Language). ADONIS offers input supporting dialogs for entering data. The table below (see fig. 65) shows the performer assignment in the objects of the class "activity" in the model "decline application".

	Performer
⊖ 1. SP Decline application	
■ File application	{{"Secretary" : "Role"} <- "Has role"}
■ Inform applicant	{{"Secretary" : "Role"} <- "Has role"}

Figure 65: Performer assignment in the business process model "decline application"

9.2 Models from the file Example-General_with_resources.adl

The file "Example-General_with_resources.adl" consists of

Company map

- ""**Applying for vacation (resource)**"" (see chap. 9.2.2, p. 263),

Business Process Model

- "**Application for vacation (resource)**" (see chap. 9.2.2.3, p. 264),
- "**Decline application (resource)**" (see chap. 9.2.2.4, p. 266)

, Working Environment model

- "**Application department (resource)**" (see chap. 9.2.2.2, p. 264).

and Document model

- ""**Document model (Application for vacation - resource)**"".

This file contains the same models as the file "Example-General.adl" (see chap. 9.1, p. 255) but additionally includes **resources** that are required to execute activities.

Defining application model:

If you want to simulate models of the file "example - general", you have to define the application model before running "capacity analysis" or "workload analysis".

The application model consists of a Business Process Model

- "Application for vacation (resource)" as well as a Working Environment model
- "Application department (resource)".

9.2.1 Problem description

In addition to the problem statement, there also are the following requirements:

- Each performer in the "Application department" has their own PC. There is an additional PC for the department as well.
- Activities in the business process "Application for vacation" and in subprocess "Decline application" are performed with support of the resources (PC).
- Simulation runs should assure that the performer uses its own PC to carry out the activity.

9.2.2 Modelling in ADONIS

The described problem (see chap. 9.2.1, p. 263) is implemented through the working environmental model "Application department" (see chap. 9.2.2.2, p. 264), (where "department 5" is modelled), Business Process Models "Application for vacation (resource)" (see chap. 9.2.2.3, p. 264) and "Decline application (resource)" (see chap. 9.2.2.4, p. 266).

9.2.2.1 Company map "Applying for vacation (resource)"

Company map "Applying for vacation (resource)" contains the process models in their hierarchical structure (see fig. 66).

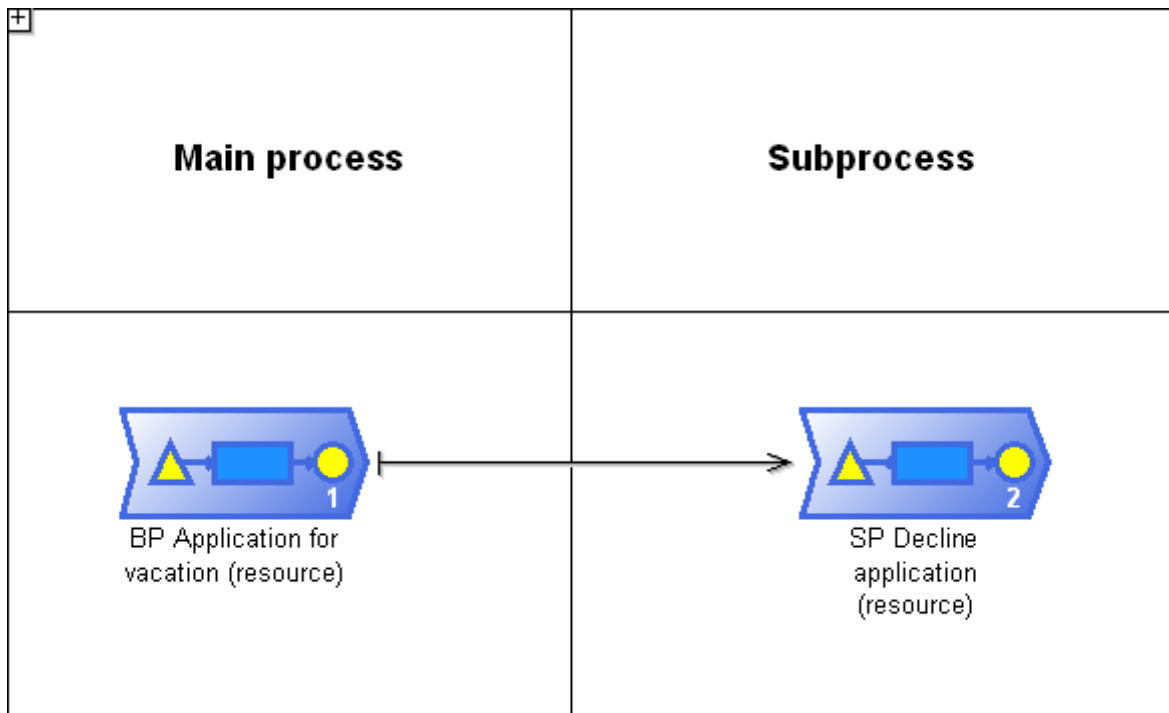

Figure 66: Company map "Applying for vacation (resources)"

9.2.2.2 WE Model "Application department (resource)"

The Working Environment model "Application department (Resource) 3.9" (see fig. 67) is the same as "Application department" (see chap. 9.1.2.2, p. 257) but also includes resources.

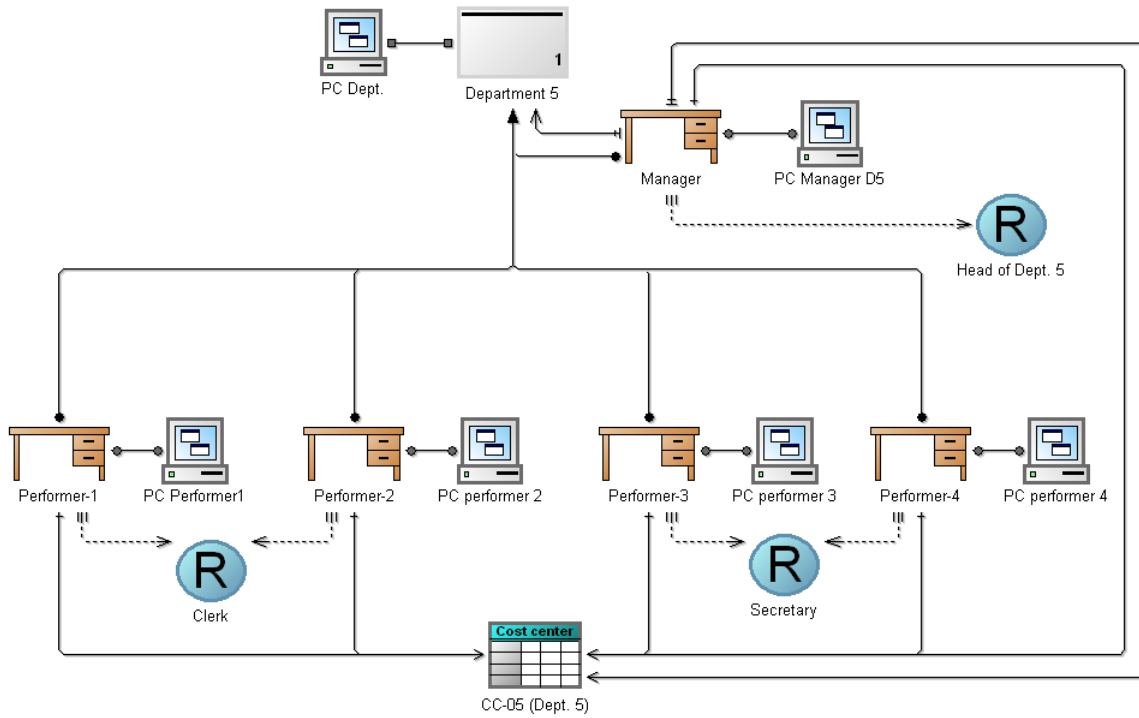

Figure 67: Working Environment model "Application department (resource)"

Objects of the class "resource" upgrade the working environment model.

The relation "uses resource" assigns performer to their "own" PC.

The relation "has resource" is used to assign "PC-dept." to the "department 5".

The table below (see fig. 68) shows values of individual resources that are located in the attribute "hourly wages".

	Hourly wages
⊖ 1. Application department (resource)	
🖨 PC Dept.	10,00
🖨 PC Manager D5	10,00
🖨 PC Performer1	10,00
🖨 PC performer 2	10,00
🖨 PC performer 3	10,00
🖨 PC performer 4	10,00

Figure 68: Hourly wages of resource in application department

9.2.2.3 BP Model "Application for vacation (resource)"

BP Model "Application for vacation (resource)" (see fig. 69) represents the business process model "application for vacation" (see chap. 9.1.2.3, p. 258) expanded with resources.

Reference overview					
R	A	C	I	In	Out
Cleek	Head of Dept. 5			Application for vacation	
Cleek	Head of Dept. 5				
Cleek	Head of Dept. 5	Secretary			
Secretary	Head of Dept. 5				
Secretary	Head of Dept. 5			Application for vacation (approved)	

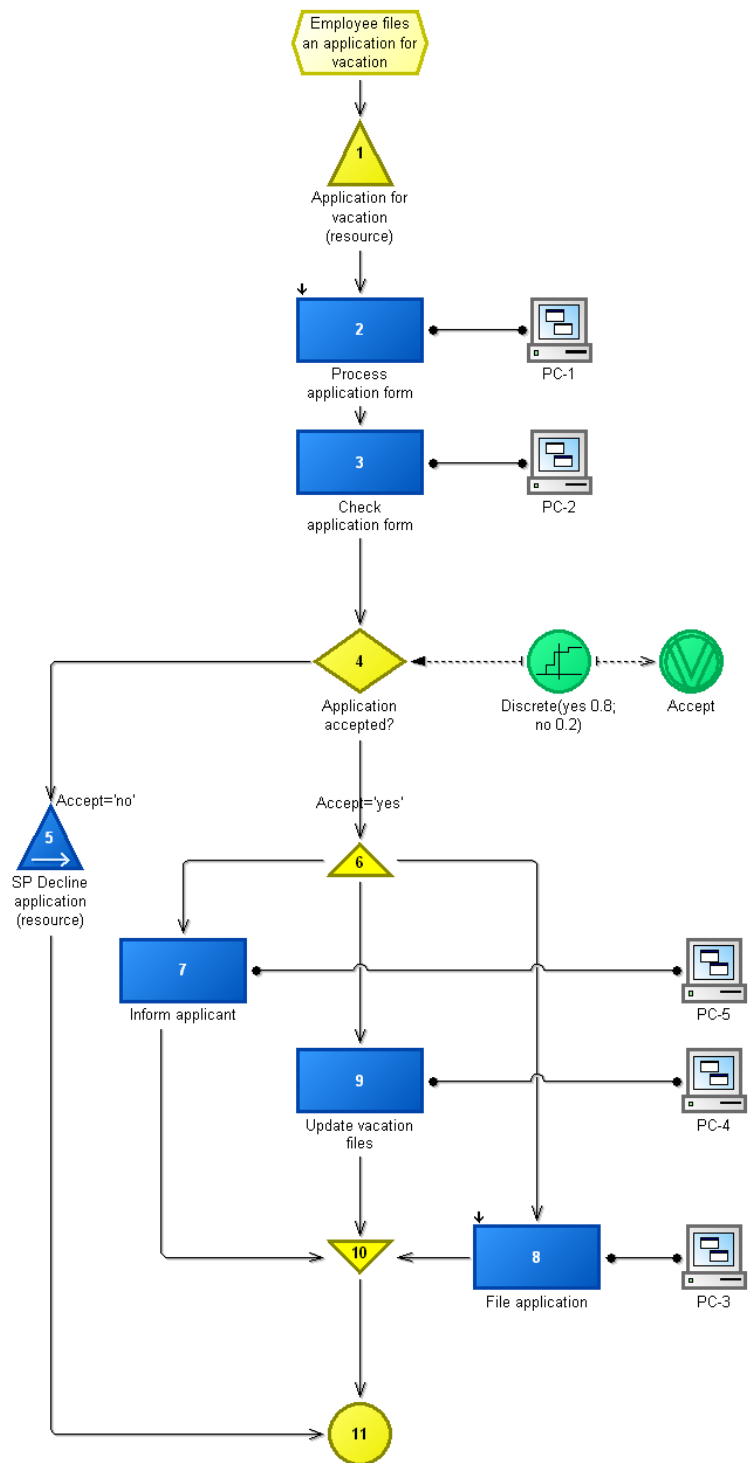

Figure 69: Business process model "Application for vacation (resource)"

To show that activities are supported by resources, objects of class "activity" are connected with resources via the relation "uses". Those resources are considered as placeholders.

Part III

Then in the attribute "selection" of class object "resource" a particular resource is assigned from the appropriate working environment model (see fig. 70).

	Selection
⊖ 1. BP Application for vacation (resource)	
PC-1	(current performer -> "Uses resource")
PC-2	(current performer -> "Uses resource")
PC-3	(current performer -> "Uses resource")
PC-4	(current performer -> "Uses resource")
PC-5	(current performer -> "Uses resource")

Figure 70: Resource assignment in the business process model "Application for vacation (resource)"

To ensure that a performer carries out an activity with their own PC, the value (current performer -> "uses resource") is entered in the attribute "selection".

9.2.2.4 BP Model "Decline application (resource)"

BP Model "Decline application (resource)" (see fig. 71) contains the business process model "Decline application" (see chap. 9.1.2.4, p. 261) updated with resources.

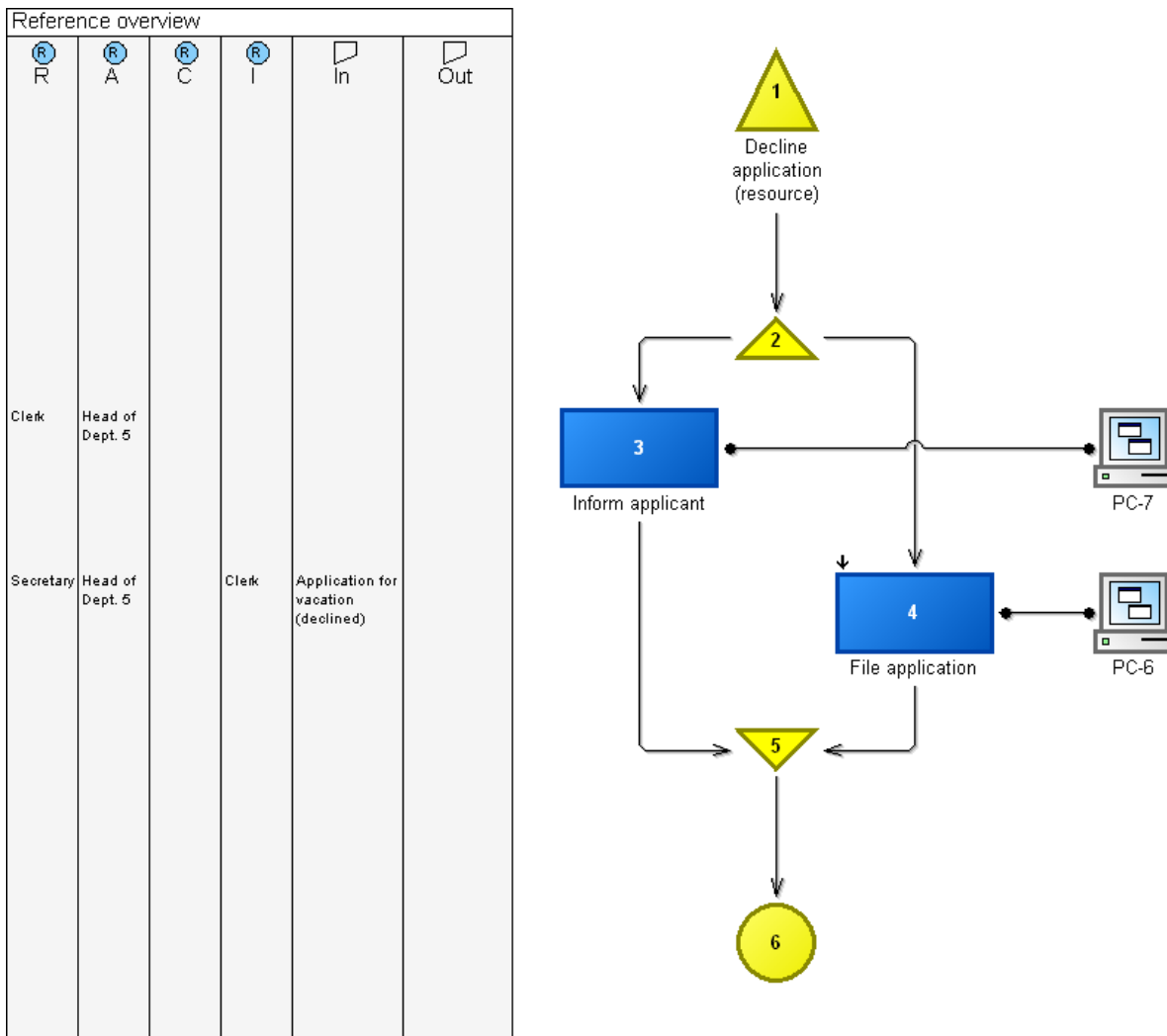

Figure 71: Business process model "Decline application (resource)"

Relation "uses" assigns a resource to objects "decline application (resources)" and "inform applicant" of the class "activity". Those resources (PC-6 and PC-7) are placeholders for assigned resources in the working environment model.

In the attribute "selection" of the object "PC-6" and "PC-7" the activity will assign a concrete resource from the corresponding working environmental model (see fig. 72).

	Selection
⊖ 1. SP Decline application (resource)	
PC-6	(current performer -> "Uses resource")
PC-7	(current performer -> "Uses resource")

Figure 72: Resources assignment in the business process model "Decline application (resource)"

To ensure that performers use their own PC to perform the activity, the attribute "selection" of the class "resource" contains the value "(current performer -> uses resource)".

9.3 Models from the file "example-assurance.adl"

The file "example-assurance.adl" consists of:

Company map

- **"Processes in Customer service dept Life Assurance"** (see chap. 9.3.2, p. 268),

Business process models

- **"BP Contract value enquiries (written)"** (see chap. 9.3.2.2, p. 271),
- **"BP Change of address"** (see chap. 9.3.2.3, p. 273),
- **"BP Change Name of Policy Holder"** (see chap. 9.3.2.4, p. 274),
- **"BP Change of beneficiary"** (see chap. 9.3.2.5, p. 275),
- **"SP Policy Update"** (see chap. 9.3.2.6, p. 276),
- **"SP Dispatch written evaluation"** (see chap. 9.3.2.7, p. 277),

Working Environments model

- **"Customer Service Dept"** (see chap. 9.3.2.1, p. 269),

Document model

- **"Customer service dept Life assurance"** (see chap. 9.3.2.8, p. 277)

and Use case diagram

- **"Customer database"** (see chap. 9.3.2.9, p. 278).

With these models, it is not possible to represent business processes of the life insurance company. You will find more detailed model descriptions in the chapter modelling in ADONIS (see chap. 9.3.2, p. 268).

Defining the application model:

If you want to simulate models of the file "example - assurance", you have to define the application model before running "capacity analysis" or "workload analysis".

Part III

The application model consists of: Business process models

- "BP Change of address",
- BP Change name of policy holder",
- BP "Change of beneficiary"
- BP "Contract value enquiries (written)"

as well as Working environmental model

- "Customer service dept".

9.3.1 Problem description

A branch of an insurance company has a "customer service department" with 2 departments: "services" and "enquiries". One performer works in the "enquiries" department and 3 performers in the "services" department.

A performer in "enquiries" manages customers' questions regarding current contracts. The clerk gets performance data and responds to clients in the form of letters. Department "services" updates clients' data (addresses, names or beneficiary). Applied changes are sent to clients by mail. All clerks in the "service" department have the possibility to perform corrections on client's data.

During **the contract value enquiries** the existing contract is checked. The established values are checked and obtained performance data is reported to customers (in written form). However, the process of "writing letters" occurs in an identical form in a different department of the enterprise. If the performance data does not exist, the customer and agent will be informed (in written form).

The business process **change of beneficiary** describes that changed applications will be issued to the existing beneficiary. Then the check has to be performed to examine if changes have been applied or not. There are two possible results: either it is possible to change and apply beneficiary or it cannot be changed and the business process ends, because the request cannot be fulfilled.

In the case of an address change, the address will be searched for in the address database to check if it exists and a decision made about the address origin (home or foreign). If it is a home address, a new address can be entered into the system. If the address is foreign, authorization of delivery has to be checked before entering the data into the system. The business process ends with the letter preparation that informs the customer about the change.

If a policy holder requests to change his name, the existing name will be searched in the address database and the name will be changed. A letter regarding the change will be sent to the customer.

The flow of the process "writing a letter" is the same in every department.

9.3.2 Modelling in ADONIS

The modelling of the problem description (see chap. 9.3.1, p. 268) occurs

- In the working environment model "Customer service dept", where both departments "services" and "enquiries" are established,
- In the business processes "BP Contract value enquiries (written)", "BP Change of address", "BP Change name of policy holder" and "BP Change of beneficiary", as well as in sub processes "SP dispatch written evaluation" and "SP policy update".
- in the document model "Customer service dept. Life Assurance" and
- in use case diagram "Customer database"

A connection between processes and subprocesses and appropriate departments are represented in the company map (see fig. 73):

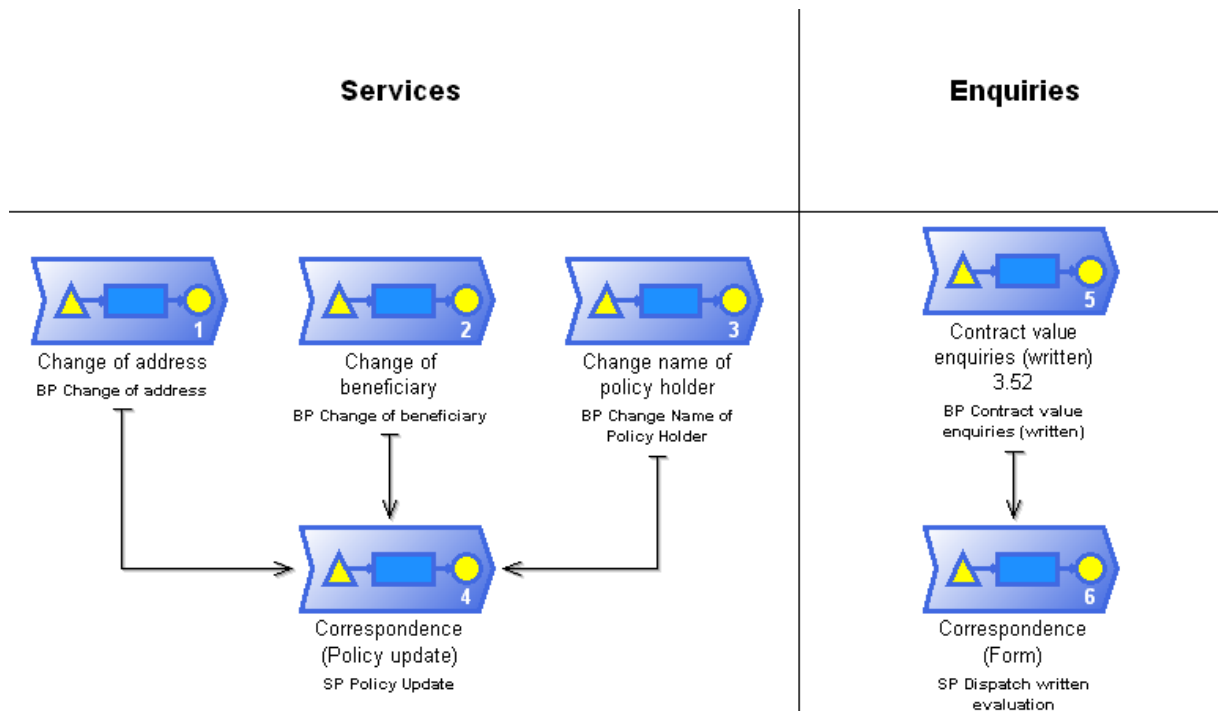

Figure 73: Company map "processes in the customer service dept."

9.3.2.1 WE Model "Customer service dept."

Modelling the organisational structure is drawn in a working environment model (see fig. 74).

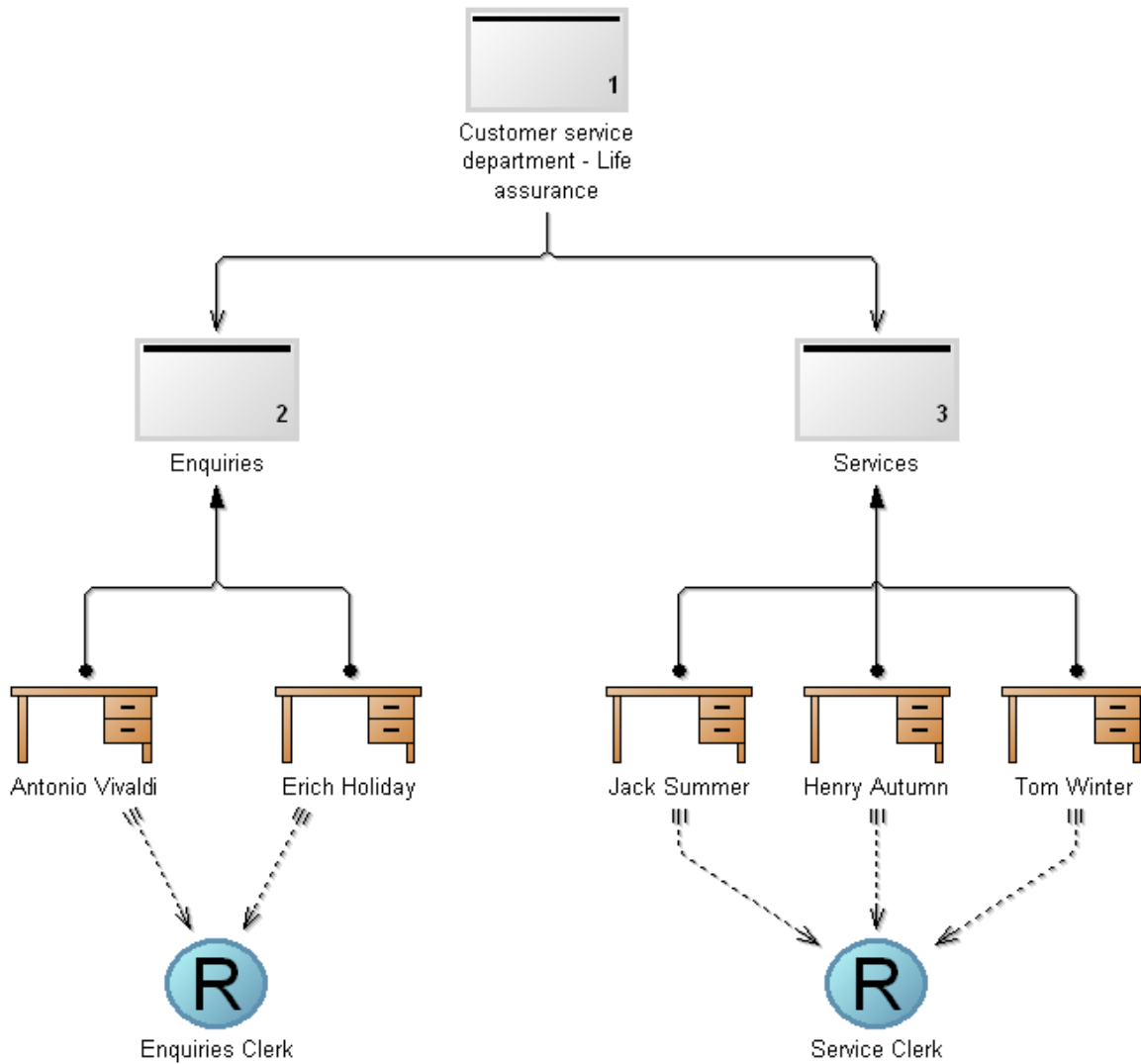

Figure 74: WE Model "customer service dept."

The model contains three organisation units and four performers. The organisation units have the following names: "Services", "Enquiries" and "Customer service dept. Life assurance". This time, performers have names: "Edward Spring" from "Enquiries" department and "Jack Summer", "Henry Autumn" and "Tom Winter" from "services" department.

The area of a performer's responsibility is modelled as a "role". The performer of "enquiries" has the role "Clerk Enquiries". Three performers from the department "Services" have the role "Service Clerk". The role assignment is arranged by the relations "has role" and the assignment to the department is arranged by the relation "belongs to".

The below table (see fig. 75) shows the assignment of performers to activities in all of the business process models.

	Performer
⊖ 1. BP Change Name of Policy Holder	
■ Enter new name into database	{{"Service Clerk": "Role"} <- "Has role"}}
■ Search for customer in customer database	{{"Service Clerk": "Role"} <- "Has role"}}
⊖ 2. SP Policy Update	
■ Send endorsement	{{"Enquiries Clerk": "Role"} <- "Has role"}}
■ Write policy endorsement	{{"Enquiries Clerk": "Role"} <- "Has role"}}
⊖ 3. BP Change of beneficiary	
■ Check change request for modifications	{{"Service Clerk": "Role"} <- "Has role"}}
■ Determine creditor	{{"Service Clerk": "Role"} <- "Has role"}}
■ Enter new names in system	{{"Service Clerk": "Role"} <- "Has role"}}
■ Inform insurance agent	{{"Service Clerk": "Role"} <- "Has role"}}
■ Inspect policy contract	{{"Service Clerk": "Role"} <- "Has role"}}
■ Search for customer in customer database	{{"Service Clerk": "Role"} <- "Has role"}}
⊖ 4. BP Contract value enquiries (written)	
■ Calculate the value	{{"Enquiries Clerk": "Role"} <- "Has role"}}
■ Check contract	{{"Enquiries Clerk": "Role"} <- "Has role"}}
■ Inform insurance agent	{{"Enquiries Clerk": "Role"} <- "Has role"}}
⊖ 5. SP Dispatch written evaluation	
■ Dispatch letter	{{"Service Clerk": "Role"} <- "Has role"}}
■ Write letter	{{"Service Clerk": "Role"} <- "Has role"}}
⊖ 6. BP Change of address	
■ Check address (domestic/foreign)	{{"Service Clerk": "Role"} <- "Has role"}}
■ Check country in risk table	{{"Service Clerk": "Role"} <- "Has role"}}
■ Contact the customer	{{"Service Clerk": "Role"} <- "Has role"}}
■ Enter new address in system	{{"Service Clerk": "Role"} <- "Has role"}}
■ Search for customer in customer database	{{"Service Clerk": "Role"} <- "Has role"}}

Figure 75: Performers assignment in the business process models

In the main business process model ("BP Application for Vacation"), the performer with the role "clerk" (services or enquiries) is assigned to the activity. At the same time, the attribute "done by" of this activity is given the value "Service clerk" or "Enquiries clerk". It guarantees, that the performer that is assigned to the first activity also performs all of the following activities and thus there is no performer exchange.

Hint: It is possible to create a performer calendar for each performer. Check hints in the example model "Application for vacation" (see chap. 9.1.2.3, p. 258).

9.3.2.2 BP Model "Contract value enquiries (written)"

The modelling of a process flow occurs in the business process model, where "BP contract value enquiries" is represented (see fig. 76).

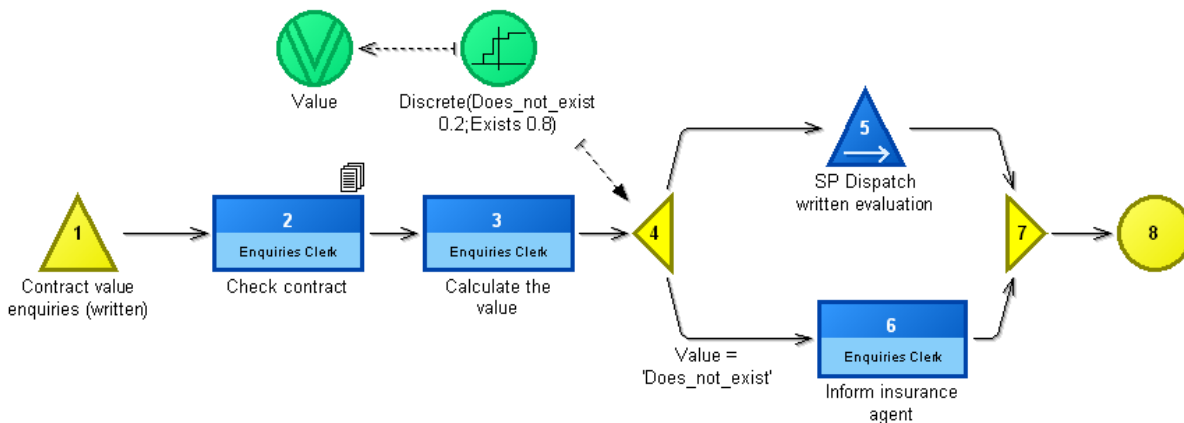

Figure 76: Business process model "BP contract value enquires"

The process flow starts with the object "process start" named "Contract value enquiries (written)".

Next, the flow follows with the objects of the class "activity": "check contract" and "calculate the value". Both activities will be carried out by the performer with the role "enquiries clerk". In this example, there is only one performer with such a status.

If the performance value is calculated, the flow splits into parallel streams. It is arranged by the "parallelity" object.

Path 1: The "SP Dispatch written evaluation" is called in most cases. As described in the problem description, the process of "Writing letters" is consistently activated. Therefore this activity is represented as a separate business process model (subprocess) to be used by different business process models.

In the business process model "contract value enquiries (written)", an object of the class "sub process" (SP dispatch written evaluation) is modelled for the process "writing letters". The reference on the model "SP dispatch written evaluation" is arranged in the ADONIS-Notebook of objects "SP dispatch written evaluation" (business process model), in the attribute "referenced subprocess" (in this case it is "SP dispatch written evaluation").

Path 2: If no performance values are present, which happens in 20% of cases where the business process model is activated, it will be presented by the random generator. The path you have to choose will be shown by the transition condition "Value=None". This value is displayed on the connector (or relation "subsequent"). If there is no performance value, it is necessary to get the written agreement from the agent regarding the missing performance value.

The "conditional parallelity" will be brought together by the object "organization". The process flows directly to the object "end", because there are no further activities.

The logic flow, and the timing of the business processes is represented in the relation "subsequent".

A "variable" is defined to enable simulation capabilities for the business process model of the "BP Contract value enquiries (written)" including referenced subprocess "SP Dispatch written evaluation". The variable is named "value". The object of the class "random generator" (statistical distribution) will be assigned to this variable by the relation "assign variable".

The discrete distribution (exists: 0,8; does not exist 0,2) (the attribute "Value" in the "random generator" class object) is referenced on the object "X" of the "parallelity" class in the "transition condition" of both relations of the "subsequent" type. With this distribution, the object "Value" of the class "variable" with probability 0,8 is set to "exists" and with probability 0,2 is set for "none". The transition condition consists of the variables "Value", logical operator "=" and a constant from the class object "Random generator" ('exists' or 'does not exist'). In this example only the transition condition "none" is modelled.

The relation "sets" connects an object of the class "random generator" with the flow. It has to be done before the object of the class "decision". In this example the "random generator" is arranged in the "parallelity" object.

The object's notebooks contain information about the objects. For example: Technical description in activities.

Hint: The performer's assignment to the activity is presented in the description of the working environmental model (see fig. 75).

9.3.2.3 BP Model "Change of address"

Modelling the process flows is described in the BP model "BP change of address" (see fig. 77).

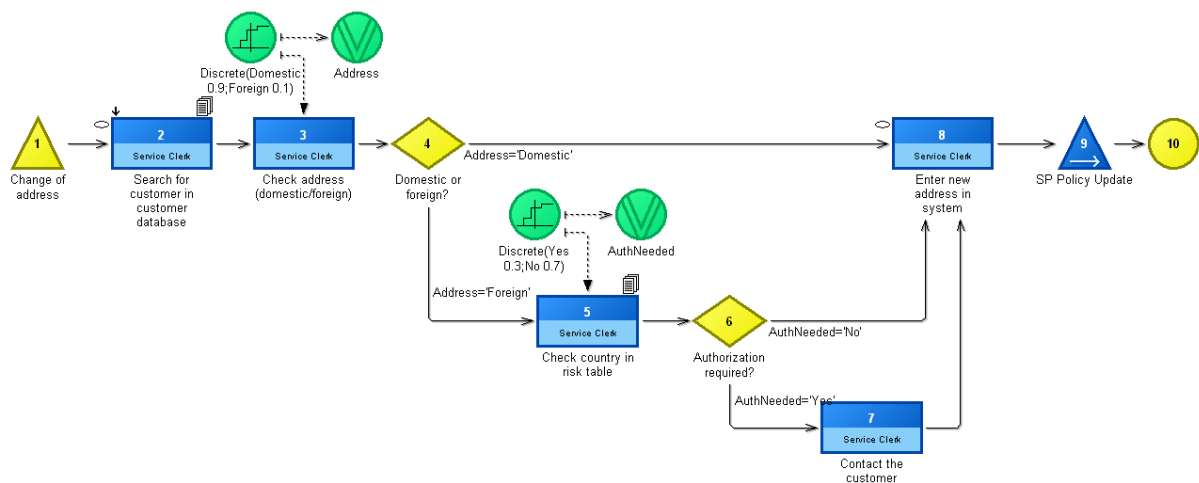

Figure 77: Business process model "BP change of address"

The flow begins with the object "change of address" of the class "process start".

After the process start object, there are two activities: "Search for customer in customer database" and "Check address (domestic/foreign)". These activities are performed by the performer with the role "service clerk".

After the activity "Check address (domestic/foreign)", the flow branches out into two paths (through the object "Domestic or foreign?" of the class "decision").

Path 1: If the address is domestic, the activity "Enter new address in system" will be carried out immediately.

Path 2: If the address is foreign, the flow is extended by some class objects. The activity "Check country in risk table" follows the class "decision" (Name: "Authorization required?") that again provides two possibilities in the process flow.

Path 3: The "decision" permits that no authorization is required. Then the flow path goes directly to the activity "Enter new address in system", that can be carried out without additional activities in the path 1.

Path 4: If the "decision" indicates that authorisation is required, the process path goes through the activity "Contact the customer" and then to the activity "Enter new address in system".

After the end of the activity "Enter new address in system", the process of "Writing letters" is shown in the form of "subprocess" ("SP Policy update"). In a different business process, the process of "Writing letters" is performed in the same form. Therefore the "Sending letters" activity is modelled on the basis of business process models in the form of subprocesses.

Part III

If the subprocess "SP Policy update" ends, the main process "BP Change of address" continues. Because there is no further activities, it ends with the object "end".

To enable simulation capability for the business process model "BP Change of address", including its subprocess "SP Policy update", the variables (in this case "Address" and "AuthNeeded") have to be defined for three optional paths. It has to be described for the decisions "Domestic or foreign?" and "Authorization required?".

The relation "sets variable" assigns the variable to the "random generator" (statistical distribution).

The statistical distribution "Discrete (domestic 0,9; foreign 0,1) (attribute "value" in the class object "random generator") is referenced after the decision class object "Domestic or foreign?" in the "transition condition" of both relations "subsequent". Through this distribution, the object "Address" of the class "Variable" is occupied with probabilities 0,8 for the value "Domestic" and 0,2 for the value "Foreign".

The relation "sets" connects the class object "random generator" with the flow. It should be arranged in the "decision" class object. Optionally, you can arrange it in the activity just before the decision.

Conditions for each path (after the decision "Domestic or foreign?") are defined in the "transition condition" of the relation type "subsequent". In path 1, where address is domestic, the value "Address='Domestic'" is entered. If address is "foreign", in the case the field is occupied with the value "Address='Foreign'" (path 2). The transition condition consists of the variables "Address", logical operator "=" and a constant from the class object "random generator" ('domestic' or 'foreign').

Hint: The performers assignment to the activity is presented by a description of a working environmental model (see fig. 75).

Hint: Take note of the models descriptions entered in the ADONIS Notebooks.

9.3.2.4 BP Model "Change name of policy holder"

The modelling of the process flow is designed in the BP Model "BP Change name of policy holder" (see fig. 78).

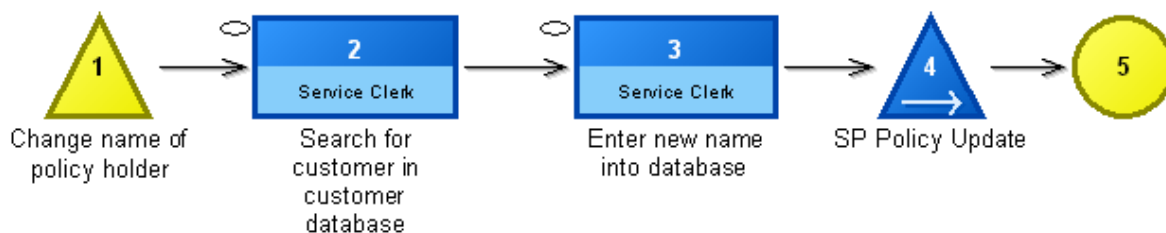

Figure 78: Business process model "BP Change name of policy holder"

The flow begins with the object "change name of policy holder" of the class "Process start".

The process flow is a sequence that begins with activities "Search for customer in customer database" and "Enter new name into database". The flow path navigates through the sub process "SP Policy Update". The object "sub process" ("SP Policy Update") is modelled.

The reference to the model "SP Policy Update" is assigned in the notebook of the object "SP Policy Update", where the attribute "referenced subprocess" contains the name of referenced business process model (in this case it is SP Policy Update).

After completing the subprocess "SP Policy Update", the flow returns to the main process "BP Change name of policy holder" and ends in the class object "end".

Hint: Performance assignments are presented in the description of the working environment model (see fig. 75).

Hint: The object's notebook contains information (attributes) such as a technical description of a given activity or number and appearance frequency of a given "process start" object (see fig. 61). They show the attribute values of "execution times", "waiting time", "resting time", "transport time" and "costs" in all objects of the "activity" class. The above attributes are required for simulation.

9.3.2.5 BP Model "BP change of beneficiary"

Modelling of the process flow is designed in the business process model (see fig. 79).

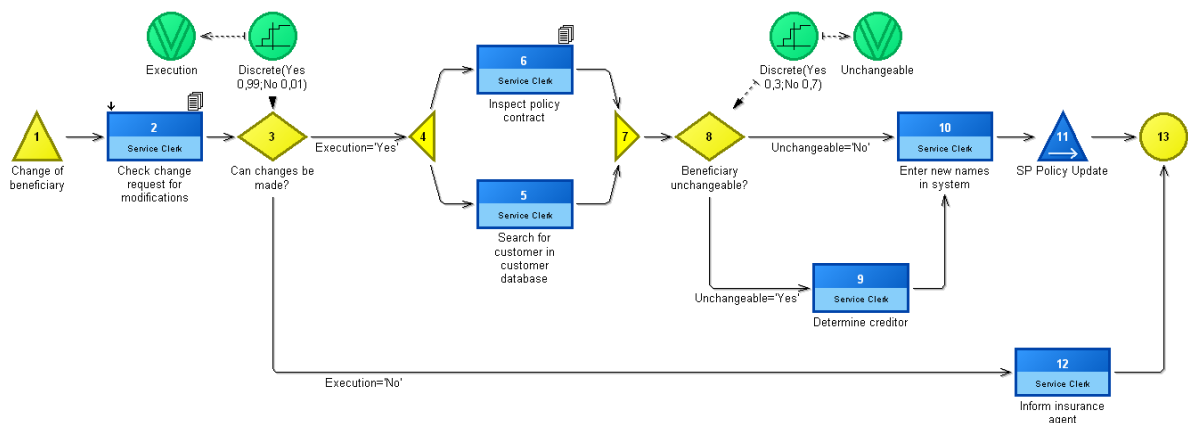

Figure 79: Business process model "BP change of beneficiary"

The flow begins with the object "Change of beneficiary" of the class "process start".

The activity "Check change request for modifications" follows the process start. The activity is carried out by a "Service clerk" performer.

After the activity "Check change request for modifications", the flow branches out into two paths (through the object "Can changes be made?").

Path 1: The flow branches out in the object "Parallelity". It specifies what activities should be executed at the time. Execution order within parallelities is arbitrary. Activities can also be accomplished by different performers (in this example there are two activities: "Inspect policy contract" and "Search for customer in customer database"). If both activities are performed, the flow reaches the object "Merging".

After merging, all objects have to be executed in the sequence. The process flows to the decision object "Beneficiary unchangeable?", with two optional flow paths.

Path 3: Beneficiary is revocable and the activity "Enter new names in system" is immediately executed.

Path 4: The beneficiary is revocable and the activity "Determine creditor" is executed. After that, the activity "Enter new names in system" is performed.

Because two branches in the activity "Enter new names in system" run together, the main process continues and flows into the subprocess "SP Policy Update".

The reference on the "SP Policy Update" is arranged to the object's "SP Policy Update" notebook (the name of the process is assigned in the attribute "referenced subprocess" - in this case it is SP Policy Update. After completing the subprocess "SP Policy Update" the flow returns to the main process "BP change of beneficiary" and ends in the class object "end".

Part III

Path 2: If changes cannot be made, the activity "Inform insurance agent" is performed and the flow returns to the main process "BP change of beneficiary" and ends in the class object "end".

The flow logic - the chronological and logic flow of the business processes is represented by the relation "subsequent".

"Variables" for three optional paths (after decisions "Can changes be made?" and "Beneficiary unchangeable?") need to be defined to enable simulation capability for the business process model "BP change of beneficiary", including the sub process "SP Policy update"..

The relation "sets variable" assigns the variable to the class object "random generator" (statistical distribution).

The discrete distributions "Discrete (yes 0.99; no 0.01)" and "Discrete (yes 0.3; no 0.7)" (attribute "value" in the Object of the class "random generator") are referenced in the "transition condition" section of relation "subsequent". The reference is arranged before objects "Domestic or foreign?" and "Beneficiary unchangeable?". Through this distribution the object "execution" of the class "variable" sets the value "yes" with the probability 0.99 and the value "no" with probability 0.01. The object "unchangeable" of the class "variable" sets the value "yes" with the probability 0.3 and the value "no" with the probability 0.7.

The relation "sets" connects objects of the class "random generator" with the flow. Ideally it is assigned at the time of the particular decision.

The flow conditions of particular paths are defined in the "transition condition" section of the relation "subsequent" (after the decisions "Can changes be made?" and "Beneficiary unchangeable?"). In the transition condition of the path that is coming out of the decision "Can changes be made?", the execution value is set to "yes". In path 2, (changes are unavailable), the execution value is set to "no". In case of unchangeable right to the life assurance, the unchangeable "no", if changes are possible the value is set to "yes" path 4).

The transition condition consists of the variable name "execution" or "unchangeable", logical operator "=" and the constant from the class object "random generator" "yes or no".

Hint: The performer's assignment to the activities is represented in the description of the working environment model (see fig. 75).

Hint: See details regarding ADONIS notebook entry in the description of the other models.

9.3.2.6 BP Model "SP Dispatch written evaluation"

The subprocess "SP Dispatch written evaluation" is displayed as an independent business process model (see fig. 80).

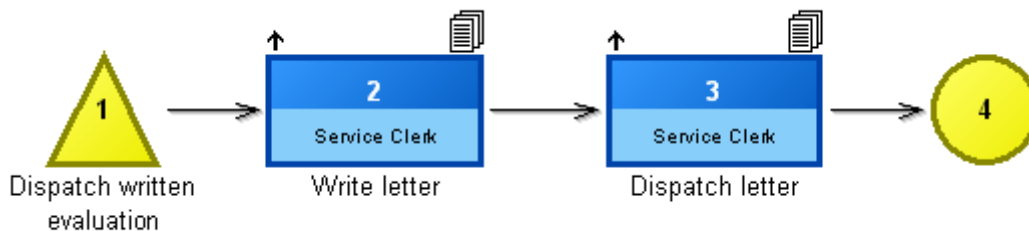

Figure 80: Business process model "SP Dispatch written evaluation"

The flow within the model begins with the process start object "Dispatch written evaluation". Following the start object there are two activity objects "Write letter" and "Dispatch letter". Both activities are carried out by the class object "performer" with the role "service clerk" from the services department.

After completing both activities, the subprocess ends.

The logic flow is created by connecting the objects with the relation type "subsequent".

Hint: The performer's assignment to the activities is represented in the description of the working environment model (see fig. 75).

Hint: See details regarding ADONIS notebook entry in the description of other models.

9.3.2.7 BP Model "SP Policy update"

The subprocess "SP Policy update" is displayed as an independent business process model (see fig. 81).

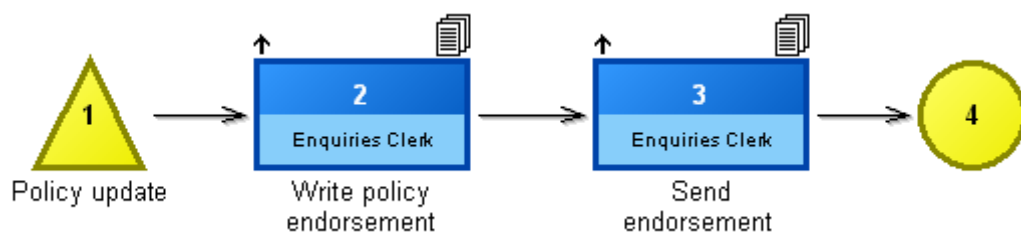

Figure 81: Business process management "SP Policy update"

The flow within the model begins with the process start object "Policy update". Following the start object there are two activity objects: "Write policy endorsement" and "Send endorsement". Both activities are carried out by the class object "performer" with the role "Enquiries clerk" from the enquiries department.

After completing both activities, the subprocess ends.

The logic flow is created by connecting the objects with the relation type "subsequent".

Hint: The performer's assignment to the activities is represented in the description of the working environment model (see fig. 75).

Hint: See details regarding ADONIS notebook entry in the description of other models.

9.3.2.8 Document model "Customer service dept Life Assurance"

The document model "Customer service dept Life Assurance" contains all the documents that are required for the modelled processes (see fig. 82).

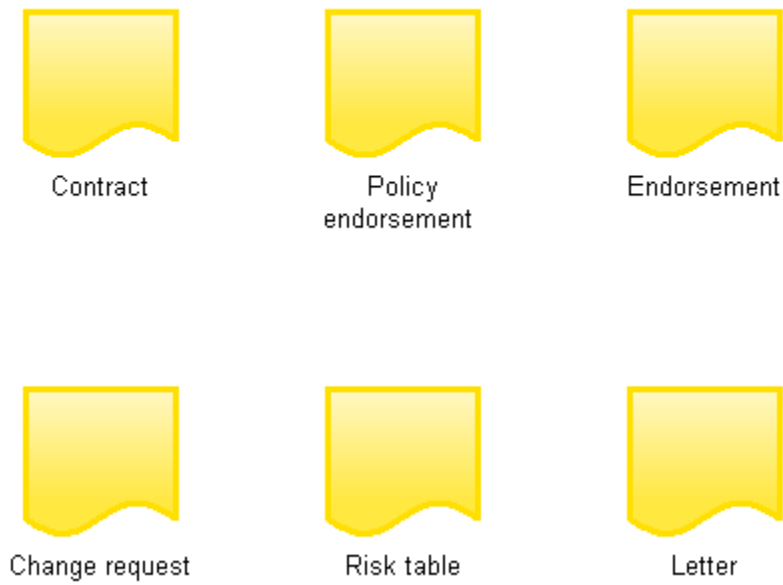

Figure 82: Document model "Customer service department"

The six documents: "Contract", "Policy endorsement", "Endorsement", "Change request", "Risk table" and "Letter" are modelled without connectors, because they are independent from each other.

In the process models, documents are referenced in the corresponding activities. On the graphics surface area, the reference is displayed as the symbol on top of the activity.

9.3.2.9 Use case diagrams "Customer database"

A use case diagram "Customer database" shows the EDP solution "Customer database" with its possibilities available for the user (role "Service clerk") (see fig. 83).

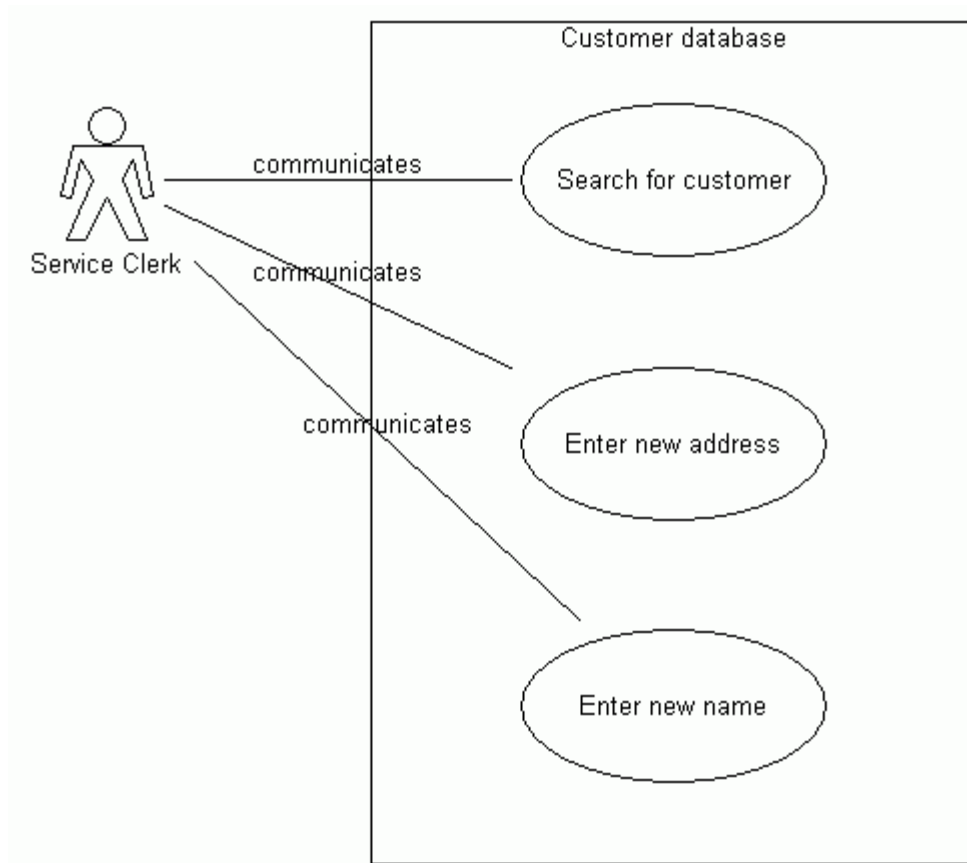

Figure 83: Use case diagram "Customer database"

Every use case diagram: "Search for customer", "Enter new address", "Enter new name" can be requested at the same time by the system and the option in the program.

The role "clerk" in service department references this actor in the working environment model.

9.4 Models of the example-bank.adl

The ADL file "Example-Bank.adl" consists of

Company map

- "Voucher-bound transfer",

Business Process Models

- "BP Voucher-bound transfer",
- "SP Accept transfer",
- "SP Control signature/blocks",
- "SP Digitalize transfer",

Working Environment model

- "Organisational structure Bank",

Document model

Part III

- "Documents (transfer)"

Use Case Diagram

- "Use cases (bank)",

and Product model

- "Voucher-bound transfer".

These models show the voucher-bound transfer in the bank and its interrelations.

Definition of an application model:

If you want to simulate models of the file "example-bank.adl", you have to define an application model before execution of a "Capacity analysis" or "Workload analysis".

The application model consists of the Business Process Model

- "Voucher-bound transfer",
as well as a Working Environment model
- "Organizational structure Bank".

9.5 Models of the file "Example - Public Sector.adl"

The ADL file "Example - Public Sector.adl" consists of

Company map

- "Construction approval",

Business Process Models

- "BP Construction Approval Application",
- "SP Application processing",
- "SP Document shipping",
- "SP New customer registration",

Working Environment model

- "Organisational structure (Construction office)"

Document model

- "Documents (Construction approval)",

Product model

- "Product and service catalogue",

IT system model

- "IT systems (construction approval)"

and Use case diagram

- **"Use case diagrams (construction approval procedure)".**

Those models illustrate the flow of the creation of construction approval. This is displayed for the public sector and its interrelations.

Definition of an application model:

If you want to simulate models of the file "Example - Public Sector.adl", you have to define a use case diagram before the execution of a "capacity analysis" or "workload analysis".

Business Process Model

- "BP Construction Approval Application",

and Working Environment model

- "Organisational structure (Construction office)".

9.6 Models of the "example-health.adl"

The ADL file "example-health.adl" consists of

Company maps

- "Value added chain hospital",
- "Diagnostics",
- "Patient admission"

Business Process Models

- "BP Patient admission",
- "SP Diagnosis planning",
- "SP Issue first aid certificate",
- "SP Patent entry",
- "SP Ward reception"

Working Environment models

- "Hospital",
- "Patient administration",

Product model

- "Product map hospital",

and IT system model

- "IT systems hospital".

Those models show the flow and its interrelations of patient administration in a hospital.

Definition of an application model:

If you want to simulate models of the file "example-health.adl", you have to define an application model before the execution of a "capacity analysis" or "workload analysis".

The application model consists of the Business Process Model

- "BP Patient admission",

and Working Environment model

- "Patient administration".

9.7 Models of the file "example-telecommunication.adl"

The file "example-telecommunication.adl" consists of

Company map

- "Application and settlement for the post-paid phones",

Business Process Models

- "BP Post-paid settlement",
- "SP Post-paid activation",
- "SP Post-paid finalisation",

Document model

- "Documents (post-paid settlement)"

Working Environment model

- "New applications"

Product model

- "Mobile telephony products"

and IT system model

- "Systems mobile telephony".

These models show the creation and interrelations of application and settlement for the post-paid phones.

Definition of an application model:

If you want to simulate models of the file "example-telecommunications.adl", you have to an define application model before the execution of a "capacity analysis" or "workload analysis".

The application model consists of the Business Process Model

- "Post-paid settlement",

and Working Environment model

- "New applications".

Part IV

Information for ADONIS administrators

If you change attributes, the program call can be helpful to recover default settings. In this situation you can use this chapter as the reference manual to compare the default settings with your current status.

In this chapter following topics are described:























- Class attributes (see chap. 1., p. 284)
- Library attributes (see chap. 2., p. 515)









1. Class attributes

- GraphRep (see chap. 1.1, p. 284)
- AttrRep (see chap. 1.2, p. 404)
- Model pointer (see chap. 1.3, p. 451)
- Class cardinality (see chap. 1.4, p. 453)
- Conversion (see chap. 1.5, p. 512)
- Allowed objects (see chap. 1.6, p. 513)





















1.1 GraphRep

The class attribute "GraphRep" is defined for the following **Classes of the ADONIS BPMS BP Library 3.9**:



	actor (see chap. 1.1.1, p. 286)
	use case (see chap. 1.1.2, p. 287)
	system boundary (see chap. 1.1.3, p. 288)
	Trigger (see chap. 1.1.4, p. 288)
	Process start (see chap. 1.1.5, p. 292)
	Subprocess (see chap. 1.1.6, p. 296)
	Activity (see chap. 1.1.7, p. 298)
	Decision (see chap. 1.1.8, p. 304)
	Parallellity (see chap. 1.1.9, p. 305)
	Merging (see chap. 1.1.10, p. 306)
	End (see chap. 1.1.11, p. 307)
	Variable (see chap. 1.1.12, p. 308)
	Random generator (see chap. 1.1.13, p. 309)
	Resource (see chap. 1.1.14, p. 310)
	Process (see chap. 1.1.15, p. 313)
	Performance indicator overview (see chap. 1.1.16, p. 315)
	Performance indicator (see chap. 1.1.17, p. 316)
	Document (see chap. 1.1.18, p. 319)
	Note (see chap. 1.1.19, p. 321)
	Aggregation (see chap. 1.1.20, p. 323)
	Swimlane (horizontal) (see chap. 1.1.21, p. 326)
	Swimlane (vertical) (see chap. 1.1.22, p. 336)

-  External partner (see chap. 1.1.23, p. 346)
-  Product (see chap. 1.1.24, p. 348)
-  Product component (see chap. 1.1.25, p. 350)
-  Application (see chap. 1.1.26, p. 351)
-  Service (see chap. 1.1.27, p. 353)
-  Performance (see chap. 1.1.28, p. 355)
-  Infrastructure element (see chap. 1.1.29, p. 357)
-  Cross-reference (see chap. 1.1.30, p. 358)







The class attribute "GraphRep" is defined for the following **Relation classes of the ADONIS BPMS BP Library 3.9:**

-  Subsequent (see chap. 1.1.41, p. 391)
-  Sets variable (see chap. 1.1.42, p. 392)
-  Sets (see chap. 1.1.43, p. 392)
-  Parameter (see chap. 1.1.44, p. 393)
-  Call parameter (see chap. 1.1.45, p. 393)
-  Uses (see chap. 1.1.46, p. 393)
-  communicates (see chap. 1.1.47, p. 393)
-  Value flow (see chap. 1.1.48, p. 394)
-  Generalisation (see chap. 1.1.49, p. 395)
-  contains (see chap. 1.1.50, p. 395)
-  extends (see chap. 1.1.51, p. 396)
-  uses (see chap. 1.1.52, p. 396)
-  Has process (see chap. 1.1.53, p. 397)
-  has Subdocument (see chap. 1.1.54, p. 398)
-  has (see chap. 1.1.55, p. 398)
-  has (see chap. 1.1.56, p. 399)
-  uses (see chap. 1.1.57, p. 399)
-  Is dependent on (see chap. 1.1.58, p. 400)
-  Owns (see chap. 1.1.59, p. 401)
-  has Note (see chap. 1.1.60, p. 401)
-  has Cross-reference (see chap. 1.1.61, p. 401)











The class attribute "GraphRep" is defined for the following **Classes of the ADONIS BPMS WE Library 3.9:**

-  Organizational unit (see chap. 1.1.31, p. 360)
-  Performer (see chap. 1.1.32, p. 365)
-  Role (see chap. 1.1.33, p. 366)

Part IV

-  **Position (see chap. 1.1.34, p. 367)**
-  **Resource (see chap. 1.1.35, p. 368)**
-  **Cost center (see chap. 1.1.36, p. 370)**
-  **Aggregation (see chap. 1.1.37, p. 371)**
-  **Note (see chap. 1.1.38, p. 373)**
-  **Swimlane (horizontal) (see chap. 1.1.39, p. 375)**
-  **Swimlane (vertical) (see chap. 1.1.40, p. 383)**

The class attribute "GraphRep" is defined for the following **Relation classes of the ADONIS BPMS WE Library 3.9:**

-  **Is subordinated (see chap. 1.1.62, p. 401)**
-  **has Resource (see chap. 1.1.63, p. 402)**
-  **has position (see chap. 1.1.64, p. 402)**
-  **Belongs to (see chap. 1.1.65, p. 402)**
-  **Is manager (see chap. 1.1.66, p. 402)**
-  **Has role (see chap. 1.1.67, p. 403)**
-  **Uses resource (see chap. 1.1.68, p. 403)**
-  **Is charged to (see chap. 1.1.69, p. 403)**
-  **Is cost center manager (see chap. 1.1.70, p. 403)**
-  **has Note (see chap. 1.1.71, p. 404)**

1.1.1 Class "actor"

ADONIS BPMS BP Library 3.9:

```
GRAPHREP
AVAL refOrga:"Referenced organizational unit"
AVAL sn:"refObjectNameEN"
AVAL sp:"Language"
IF (sp = "System")
  IF (_uilang = "de")
    SET sp:"German"
  ELSE
    SET sp:"English"
  ENDIF
ENDIF
AVAL set-default:"white" f:"Color"
AVAL set-default:"no" mono:"Monochrome view"
IF (mono = "yes")
  SET bMono:1
ELSE
  SET bMono:0
ENDIF
IF (bMono)
  SET color_fill:(rgbval("white"))
  SET color_red:(rgbval("black"))
ELSE
  SET color_fill:(rgbval(f))
```



```

    SET color_red:(rgbval("red"))
ENDIF
FILL color:(color_fill)
SHADOW off
PEN w:0.02cm
ELLIPSE x:0.00cm y:-.72cm rx:0.23cm ry:0.23cm
POLYGON 15 x1:-.46cm y1:-.46cm x2:.46cm y2:-.46cm x3:.6cm y3:.2cm
x4:.47cm y4:.23cm x5:.35cm y5:-.25cm x6:.2cm y6:0cm x7:.53cm y7:.805cm
x8:.3cm y8:.805cm x9:0cm y9:.23cm x10:-.3cm y10:.805cm x11:-.53cm
y11:.805cm x12:-.2cm y12:0cm x13:-.35cm y13:-.25cm x14:-.47cm y14:.23cm
x15:-.6cm y15:.2cm
IF (refOrga = "")
IF (sp = "English")
    ATTR "Name" x:c:0.0cm y:.9cm w:c:3.00cm h:t
    ELSE
    ATTR "Bezeichnung" x:c:0.0cm y:.9cm w:c:3.00cm h:t
    ENDIF
ELSE
IF (sp = "English")
    ATTR "Referenced organizational unit" format:"%o" x:c:0.0cm y:.9cm w:c:3.00cm
h:t
    ELSE
    ATTR "Referenced organizational unit" text:(sn) format:"%o" x:c:0.0cm y:.9cm
w:c:3.00cm h:t
    ENDIF
ENDIF
AVAL oF:"Open questions"
IF (
    LEN(replall(replall((oF)," ",""),"
",""))>0
)
    FONT "Helvetica" h:10.0pt bold color:(color_red)
    TEXT "?" x:.45cm y:-1.2cm
ENDIF

```

1.1.2 Class "use case"

ADONIS BPMS BP Library 3.9:

```

GRAPHREP
AVAL sp:"Language"
IF (sp = "System")
    IF (_uilang = "en")
        SET sp:"English"
    ELSE
        SET sp:"German"
    ENDIF
ENDIF
PEN w:0.02cm
SHADOW off
FILL color:white
ELLIPSE x:0.00cm y:0.00cm rx:2.00cm ry:1.00cm
IF (sp = "English")
    ATTR "Name" x:0.0cm y:0.0cm w:c:3.5cm h:c
    ELSE
    ATTR "Bezeichnung" x:0.0cm y:0.0cm w:c:3.5cm h:c
    ENDIF
AVAL v:"Details"
IF (LEN v)

```

Part IV

```
FONT color:lightgray h:8pt
IF (sp = "English")
  ATTR "Details" x:c y:1cm format:">> %m" h:t w:c:3.5cm
ELSE
  AVAL sub:"Submodelname"
  ATTR "Details" text:(">> " + sub) x:c y:1cm h:t w:c:3.5cm
ENDIF
ENDIF
AVAL oF:"Open questions"
IF (LEN (replall (replall ((oF)," ",""),"\n","")) > 0)
  FONT "Arial" h:10.0pt bold color:red
  TEXT "?" x:1.7cm y:-0.95cm
ENDIF
```

1.1.3 Class "system boundary"

ADONIS BPMS BP Library 3.9:

```
GRAPHREP layer:-2 sizing:asymmetrical
SHADOW off
TABLE x:-4cm y:-3cm w:8.0cm h:6.0cm cols:1 rows:1
STRETCH off
FILL color:white
RECTANGLE x:(tabx0) y:(taby0) w:(tabw1) h:(tabh1)
AVAL sp:"Language"
IF (sp = "System") {
  IF (_uilang = "en") {
    SET sp:"English"
  } ELSE {
    SET sp:"German"
  }
}
AVAL set-default:"inside" d:"Representation"
SET xc:((tabx0 + tabx1) / 2)
IF (d = "inside") {
  IF (sp = "German") {
    ATTR "Bezeichnung" x:(xc) y:(taby0) w:c:(tabw1 - 0.2cm) h:t
  } ELSE {
    ATTR "Name" x:(xc) y:(taby0) w:c:(tabw1 - 0.2cm) h:t
  }
} ELSE {
  IF (sp = "English") {
    ATTR "Name" x:(xc) y:(taby0) w:c:(tabw1) h:b
  } ELSE {
    ATTR "Bezeichnung" x:(xc) y:(taby0) w:c:(tabw1) h:b
  }
}
AVAL oF:"Open questions"
IF (LEN(replall(replall((oF)," ",""),"\n",""))>0)
  FONT "Arial" h:10.0pt bold color:red
  TEXT "?" x:(tabx1 - 0.05cm) y:(taby0) w:r h:b
ENDIF
```

1.1.4 Class "Trigger"

ADONIS BPMS BP Library 3.9:

```
GRAPHREP
```

```

SHADOW off
AVAL sn:"refObjectNameDE"
AVAL sName_de:"Bezeichnung"
IF (token(sn, 0, "-") = "[aleo]")
  SET sn:(sName_de)
ENDIF
AVAL sp:"Language"
IF (sp = "System")
  IF (_uilang = "en")
    SET sp:"English"
  ELSE
    SET sp:"German"
  ENDIF
ENDIF
AVAL col:"fontcolor"
AVAL b_visRefAppl:"Visualise referenced IT system elements"
AVAL s_refAppl:"Referenced IT system elements"
AVAL ext:"External documentation"
AVAL refDoc:"Referenced documents"
AVAL refTrigger:"Referenced trigger"
AVAL set-default:"no" mono:"Monochrome view"
IF (mono = "yes")
  SET bMono:1
ELSE
  SET bMono:0
ENDIF
IF (bMono)
  SET color_fill:(rgbval("white"))
  SET color_red:(rgbval("black"))
  PEN w:0.05cm
  FILL color:(color_fill)
ELSE
  SET color_fill:(rgbval("$ffff8e"))
  SET color_red:(rgbval("red"))
# start - smooth shaded colors
CLIP_POLY 6
  x1:-1.3cm y1:-.7cm
  x2: 1.3cm y2:-.7cm
  x3: 1.5cm y3: 0cm
  x4: 1.3cm y4: .7cm
  x5:-1.3cm y5: .7cm
  x6:-1.5cm y6: 0cm
GRADIENT_RECT x:-1.5cm y:-.7cm w:3.0cm h:1.4cm style:downdiag
  color1:white color2:(color_fill)
PEN w:0.08cm color:$c1c100 join:miter
FILL style:null
CLIP_OFF
# end - smooth shaded colors
ENDIF
POLYGON 6
  x1:-1.3cm y1:-.7cm
  x2: 1.3cm y2:-.7cm
  x3: 1.5cm y3: 0cm
  x4: 1.3cm y4: .7cm
  x5:-1.3cm y5: .7cm
  x6:-1.5cm y6: 0cm
PEN w:0.05cm
FONT "Arial" h:10.0pt color:black
IF (refTrigger = "")
  IF (sp = "German")
    ATTR "Bezeichnung" w:c:2.8cm h:c:1.4cm line-break:words
  
```

Part IV

```
ELSE
  ATTR "Name" w:c:2.8cm h:c:1.4cm line-break:words
ENDIF
ELSE
  IF (sp = "German")
    ATTR "Referenced trigger" text:(sn) format:"%o" w:c:2.8cm h:c:1.4cm line-
break:words
  ELSE
    ATTR "Referenced trigger" format:"%o" w:c:2.8cm h:c:1.4cm line-break:words
  ENDIF
ENDIF
IF ( token(ext, 1, "@") != "" )
  FONT "Wingdings" h:18.0pt color:(col)
  TEXT "4" x:1.35cm y:-0.7cm w:r h:b
  HOTSPOT "External documentation" x:0.83cm y:-1.43cm w:0.5cm h:0.6cm
ELSE
  IF ( refDoc != "" )
    FONT "Wingdings" h:18.0pt color:(col)
    TEXT "4" x:1.35cm y:-0.7cm w:r h:b
    HOTSPOT "Referenced documents" x:0.83cm y:-1.43cm w:0.5cm h:0.6cm
  ENDIF
ENDIF
AVAL oF:"Open questions"
IF ( LEN(replall(replall((oF), " ", ""), "
", ""))>0 )
  FONT "Arial" h:10.0pt bold color:(color_red)
  TEXT "?" x:1.45cm y:-0.75cm
ENDIF
FONT "Arial" h:8pt
IF ((b_visRefAppl = "1") AND (s_refAppl != ""))
  ATTR "Referenced IT system elements" format:"%o" x:-1.3cm y:-0.72cm w:l:2.1cm
h:b:1.5cm line-height:9pt line-break:rigorous
ENDIF
AVAL show_navigation:"Reference overview active"
IF (show_navigation = "1")
  AVAL show_products:"Products"
  AVAL show_respRole:"Responsible role (Mod.Attr.)"
  AVAL show_inout:"Input/Output"
  AVAL show_usecase:"Use cases"
  AVAL show_itsysteme:"IT systems"
  AVAL show_demiraci:"RACI/DEMI visibility"
  AVAL modDirection:"Modeling direction"
  SET cmX:0.0cm
  SET cmY:0.0cm
  SET cmDisplayWidth:1.25cm
  SET cmDisplayWidth2:1.95cm
  SET cmDisplayHeight:1.4cm
  SET cmDisplayHeight2:2.8cm
  SET cmLaneSize:1.3cm
  SET cmLaneSize2:2.0cm
  IF (modDirection = "vertical")
    #-----
    # Vertical navigation overview
    #-----
    SET cmX:0.08cm
    SET cmY:-0.75cm
    FONT "Arial" h:8pt color:black
    PEN color:darkgray outline
    # product lane
    IF (show_products = "1")
```

```

        #ATTR "Referenced products"                format:"%o"  x:abs:(cmX)  y:(cmY)
w:l:(cmDisplayWidth) h:t:(cmDisplayHeight) line-break:rigorous
        SET cmX:(cmX + cmLaneSize)
    ENDIF
    # demi/raci lane
    IF (show_demiraci = "1")
        #ATTR "Responsible for execution"          format:"%o"  x:abs:(cmX)  y:(cmY)
w:l:(cmDisplayWidth) h:t:(cmDisplayHeight) line-break:rigorous
        SET cmX:(cmX + cmLaneSize)
        #ATTR "Accountable for approving results"  format:"%o"  x:abs:(cmX)
y:(cmY) w:l:(cmDisplayWidth) h:t:(cmDisplayHeight) line-break:rigorous
        SET cmX:(cmX + cmLaneSize)
        #ATTR "Cooperation/participation"          format:"%o"  x:abs:(cmX)  y:(cmY)
w:l:(cmDisplayWidth) h:t:(cmDisplayHeight) line-break:rigorous
        SET cmX:(cmX + cmLaneSize)
        #ATTR "To inform"                          format:"%o"  x:abs:(cmX)  y:(cmY)
w:l:(cmDisplayWidth) h:t:(cmDisplayHeight) line-break:rigorous
        SET cmX:(cmX + cmLaneSize)
    ENDIF
    # responsible role lane
    IF (show_respRole = "1")
        #ATTR "Responsible role"                  format:"%o"  x:abs:(cmX)  y:(cmY)
w:l:(cmDisplayWidth) h:t:(cmDisplayHeight) line-break:rigorous
        SET cmX:(cmX + cmLaneSize)
    ENDIF
    # input/output lane
    IF (show_inout = "1")
        #ATTR "Input"                              format:"%o"  x:abs:(cmX)  y:(cmY)
w:l:(cmDisplayWidth2) h:t:(cmDisplayHeight) line-break:rigorous
        SET cmX:(cmX + cmLaneSize2)
        #ATTR "Output"                            format:"%o"  x:abs:(cmX)  y:(cmY)
w:l:(cmDisplayWidth2) h:t:(cmDisplayHeight) line-break:rigorous
        SET cmX:(cmX + cmLaneSize2)
    ENDIF
    # use case lane
    IF (show_usecase = "1")
        #ATTR "Referenced use cases"              format:"%o"  x:abs:(cmX)  y:(cmY)
w:l:(cmDisplayWidth) h:t:(cmDisplayHeight) line-break:rigorous
        SET cmX:(cmX + cmLaneSize)
    ENDIF
    # application lane
    IF (show_itsysteme = "1")
        ATTR "Referenced IT system elements"      format:"%o"  x:abs:(cmX)  y:(cmY)
w:l:(cmDisplayWidth) h:t:(cmDisplayHeight) line-break:rigorous
        SET cmX:(cmX + cmLaneSize)
    ENDIF
    ELSIF (modDirection = "horizontal")
    #-----
    # Horizontal navigation overview
    #-----
    SET cmX:-1.35cm
    SET cmY:0.58cm
    FONT "Arial" h:8pt color:black
    PEN color:darkgray outline
    # product lane
    IF (show_products = "1")
        #ATTR "Referenced products"              format:"%o"  x:(cmX)  y:abs:(cmY)
w:l:(cmDisplayHeight2) h:t:(cmDisplayWidth) line-break:rigorous
        SET cmY:(cmY + cmLaneSize)
    ENDIF
    # demi/raci lane

```

Part IV

```
IF (show_demiraci = "1")
  #ATTR "Responsible for execution" format:"%o" x:(cmX) y:abs:(cmY)
w:l:(cmDisplayHeight2) h:t:(cmDisplayWidth) line-break:rigorous
  SET cmY:(cmY + cmLaneSize)
  #ATTR "Accountable for approving results" format:"%o" x:(cmX)
y:abs:(cmY) w:l:(cmDisplayHeight2) h:t:(cmDisplayWidth) line-break:rigorous
  SET cmY:(cmY + cmLaneSize)
  #ATTR "Cooperation/participation" format:"%o" x:(cmX) y:abs:(cmY)
w:l:(cmDisplayHeight2) h:t:(cmDisplayWidth) line-break:rigorous
  SET cmY:(cmY + cmLaneSize)
  #ATTR "To inform" format:"%o" x:(cmX) y:abs:(cmY)
w:l:(cmDisplayHeight2) h:t:(cmDisplayWidth) line-break:rigorous
  SET cmY:(cmY + cmLaneSize)
ENDIF
# responsible role lane
IF (show_respRole = "1")
  #ATTR "Responsible role" format:"%o" x:(cmX) y:abs:(cmY)
w:l:(cmDisplayHeight2) h:t:(cmDisplayWidth) line-break:rigorous
  SET cmY:(cmY + cmLaneSize)
ENDIF
# input/output lane
IF (show_inout = "1")
  #ATTR "Input" format:"%o" x:(cmX) y:abs:(cmY)
w:l:(cmDisplayHeight2) h:t:(cmDisplayWidth) line-break:rigorous
  SET cmY:(cmY + cmLaneSize2)
  #ATTR "Output" format:"%o" x:(cmX) y:abs:(cmY)
w:l:(cmDisplayHeight2) h:t:(cmDisplayWidth) line-break:rigorous
  SET cmY:(cmY + cmLaneSize2)
ENDIF
# use case lane
IF (show_usecase = "1")
  #ATTR "Referenced use cases" format:"%o" x:(cmX) y:abs:(cmY)
w:l:(cmDisplayHeight2) h:t:(cmDisplayWidth) line-break:rigorous
  SET cmY:(cmY + cmLaneSize)
ENDIF
# application lane
IF (show_itsysteme = "1")
  ATTR "Referenced IT system elements" format:"%o" x:(cmX) y:abs:(cmY)
w:l:(cmDisplayHeight2) h:t:(cmDisplayWidth) line-break:rigorous
  SET cmY:(cmY + cmLaneSize)
ENDIF
ENDIF
ENDIF
```

1.1.5 Class "Process start"

ADONIS BPMS BP Library 3.9:

```
GRAPHREP
AVAL sp:"Language"
IF (sp = "System")
  IF (_uilang = "en")
    SET sp:"English"
  ELSE
    SET sp:"German"
  ENDIF
ENDIF
AVAL ext:"External documentation"
AVAL rdok:"Referenced documents"
```

```

AVAL input:"Input"
AVAL output:"Output"
AVAL col:"fontcolor"
AVAL set-default:"no" mono:"Monochrome view"
IF (mono = "yes")
  SET bMono:1
ELSE
  SET bMono:0
ENDIF
PEN w:0.05cm
IF (bMono)
  FILL color:white
ELSE
  # start - smooth shaded colors
  SHADOW off
  CLIP_POLY 3 x1:-.7cm y1:.7cm x2:.7cm y2:.7cm x3:0cm y3:-.7cm
  GRADIENT_RECT x:-.7cm y:-.7cm w:1.4cm h:1.4cm style:downdiag color1:$ffff66
  color2:$eeee00
  CLIP_OFF
  PEN w:0.08cm color:$888800 join:miter
  FILL style:null
  # end - smooth shaded colors
ENDIF
POLYGON 3 x1:-.7cm y1:.7cm x2:.7cm y2:.7cm x3:0cm y3:-.7cm
PEN
FONT color:(col)
IF (sp = "English")
  ATTR "Name" y:.8cm w:c:2.8cm h:t
ELSE
  ATTR "Bezeichnung" y:.8cm w:c:2.8cm h:t
ENDIF
AVAL i:"Order"
IF (i > "0")
  FONT "Arial" h:10.0pt bold color:black
  ATTR "Order" x:0.00cm y:0.00cm w:c:1.00cm h:c
ENDIF
AVAL oF:"Open questions"
IF (
  LEN(replall(replall((oF)," ",""),"
  ",""))>0
)
  IF (bMono)
    FONT "Arial" h:10.0pt bold color:black
  ELSE
    FONT "Arial" h:10.0pt bold color:red
  ENDIF
  TEXT "?" x:-0.55cm y:-0.50cm
ENDIF
IF ( token(ext, 1, "@") != "" )
  FONT "Wingdings" h:18.0pt color:black
  TEXT "4" x:.8cm y:-.3cm w:r h:b
  HOTSPOT "External documentation" x:0.3cm y:-1.0cm w:0.5cm h:0.6cm
ELSE
  IF ( refDoc != "" )
    FONT "Wingdings" h:18.0pt color:(col)
    TEXT "4" x:.8cm y:-.3cm w:r h:b
    HOTSPOT "Referenced documents" x:0.3cm y:-1.0cm w:0.5cm h:0.6cm
  ENDIF
ENDIF
AVAL show_navigation:"Reference overview active"
IF (show_navigation = "1")

```

Part IV

```
AVAL show_products:"Products"
AVAL show_respRole:"Responsible role (Mod.Attr.)"
AVAL show_inout:"Input/Output"
AVAL show_usecase:"Use cases"
AVAL show_itsysteme:"IT systems"
AVAL show_demiraci:"RACI/DEMI visibility"
AVAL modDirection:"Modeling direction"
SET cmX:0.0cm
SET cmY:0.0cm
SET cmDisplayWidth:1.25cm
SET cmDisplayWidth2:1.95cm
SET cmDisplayHeight:1.4cm
SET cmDisplayHeight2:2.8cm
SET cmLaneSize:1.3cm
SET cmLaneSize2:2.0cm
IF (modDirection = "vertical")
#-----
# Vertical navigation overview
#-----
SET cmX:0.08cm
SET cmY:-0.75cm
FONT "Arial" h:8pt color:black
PEN color:darkgray outline
# product lane
IF (show_products = "1")
  ATTR "Referenced products" format:"%o" x:abs:(cmX) y:(cmY)
w:l:(cmDisplayWidth) h:t:(cmDisplayHeight) line-break:rigorous
  SET cmX:(cmX + cmLaneSize)
ENDIF
# demi/raci lane
IF (show_demiraci = "1")
  #ATTR "Responsible for execution" format:"%o" x:abs:(cmX) y:(cmY)
w:l:(cmDisplayWidth) h:t:(cmDisplayHeight) line-break:rigorous
  SET cmX:(cmX + cmLaneSize)
  #ATTR "Accountable for approving results" format:"%o" x:abs:(cmX)
y:(cmY) w:l:(cmDisplayWidth) h:t:(cmDisplayHeight) line-break:rigorous
  SET cmX:(cmX + cmLaneSize)
  #ATTR "Cooperation/participation" format:"%o" x:abs:(cmX) y:(cmY)
w:l:(cmDisplayWidth) h:t:(cmDisplayHeight) line-break:rigorous
  SET cmX:(cmX + cmLaneSize)
  #ATTR "To inform" format:"%o" x:abs:(cmX) y:(cmY)
w:l:(cmDisplayWidth) h:t:(cmDisplayHeight) line-break:rigorous
  SET cmX:(cmX + cmLaneSize)
ENDIF
# responsible role lane
IF (show_respRole = "1")
  #ATTR "Responsible role" format:"%o" x:abs:(cmX) y:(cmY)
w:l:(cmDisplayWidth) h:t:(cmDisplayHeight) line-break:rigorous
  SET cmX:(cmX + cmLaneSize)
ENDIF
# input/output lane
IF (show_inout = "1")
  ATTR "Input" format:"%o" x:abs:(cmX) y:(cmY)
w:l:(cmDisplayWidth2) h:t:(cmDisplayHeight) line-break:rigorous
  SET cmX:(cmX + cmLaneSize2)
  ATTR "Output" format:"%o" x:abs:(cmX) y:(cmY)
w:l:(cmDisplayWidth2) h:t:(cmDisplayHeight) line-break:rigorous
  SET cmX:(cmX + cmLaneSize2)
ENDIF
# use case lane
IF (show_usecase = "1")
```



```

#ATTR "Referenced use cases" format:"%o" x:abs:(cmX) y:(cmY)
w:l:(cmDisplayWidth) h:t:(cmDisplayHeight) line-break:rigorous
SET cmX:(cmX + cmLaneSize)
ENDIF
# application lane
IF (show_itsysteme = "1")
ATTR "Referenced IT system elements" format:"%o" x:abs:(cmX) y:(cmY)
w:l:(cmDisplayWidth) h:t:(cmDisplayHeight) line-break:rigorous
SET cmX:(cmX + cmLaneSize)
ENDIF
ELSIF (modDirection = "horizontal")
#-----
# Horizontal navigation overview
#-----
SET cmX:-1.35cm
SET cmY:0.58cm
FONT "Arial" h:8pt color:black
PEN color:darkgray outline
# product lane
IF (show_products = "1")
ATTR "Referenced products" format:"%o" x:(cmX) y:abs:(cmY)
w:l:(cmDisplayHeight2) h:t:(cmDisplayWidth) line-break:rigorous
SET cmY:(cmY + cmLaneSize)
ENDIF
# demi/raci lane
IF (show_demiraci = "1")
#ATTR "Responsible for execution" format:"%o" x:(cmX) y:abs:(cmY)
w:l:(cmDisplayHeight2) h:t:(cmDisplayWidth) line-break:rigorous
SET cmY:(cmY + cmLaneSize)
#ATTR "Accountable for approving results" format:"%o" x:(cmX)
y:abs:(cmY) w:l:(cmDisplayHeight2) h:t:(cmDisplayWidth) line-break:rigorous
SET cmY:(cmY + cmLaneSize)
#ATTR "Cooperation/participation" format:"%o" x:(cmX) y:abs:(cmY)
w:l:(cmDisplayHeight2) h:t:(cmDisplayWidth) line-break:rigorous
SET cmY:(cmY + cmLaneSize)
#ATTR "To inform" format:"%o" x:(cmX) y:abs:(cmY)
w:l:(cmDisplayHeight2) h:t:(cmDisplayWidth) line-break:rigorous
SET cmY:(cmY + cmLaneSize)
ENDIF
# responsible role lane
IF (show_respRole = "1")
#ATTR "Responsible role" format:"%o" x:(cmX) y:abs:(cmY)
w:l:(cmDisplayHeight2) h:t:(cmDisplayWidth) line-break:rigorous
SET cmY:(cmY + cmLaneSize)
ENDIF
# input/output lane
IF (show_inout = "1")
ATTR "Input" format:"%o" x:(cmX) y:abs:(cmY)
w:l:(cmDisplayHeight2) h:t:(cmDisplayWidth) line-break:rigorous
SET cmY:(cmY + cmLaneSize2)
ATTR "Output" format:"%o" x:(cmX) y:abs:(cmY)
w:l:(cmDisplayHeight2) h:t:(cmDisplayWidth) line-break:rigorous
SET cmY:(cmY + cmLaneSize2)
ENDIF
# use case lane
IF (show_usecase = "1")
#ATTR "Referenced use cases" format:"%o" x:(cmX) y:abs:(cmY)
w:l:(cmDisplayHeight2) h:t:(cmDisplayWidth) line-break:rigorous
SET cmY:(cmY + cmLaneSize)
ENDIF
# application lane

```

Part IV

```
IF (show_itsysteme = "1")
  ATTR "Referenced IT system elements" format:"%o" x:(cmX) y:abs:(cmY)
w:l:(cmDisplayHeight2) h:t:(cmDisplayWidth) line-break:rigorous
  SET cmY:(cmY + cmLaneSize)
ENDIF
ENDIF
ENDIF
```

1.1.6 Class "Subprocess"

ADONIS BPMS BP Library 3.9:

```
GRAPHREP
SHADOW off
AVAL sp:"Language"
IF (sp = "System")
  IF (_uilang = "de")
    SET sp:"German"
  ELSE
    SET sp:"English"
  ENDIF
ENDIF
AVAL col:"fontcolor"
AVAL set-default:"x" p:"Referenced subprocess"
AVAL sub:"Referenced subprocess"
AVAL anzeige:"Display name and reference"
AVAL i:"Order"
AVAL sn:"Subprocessname"
AVAL set-default:"no" mono:"Monochrome view"
IF (mono = "yes")
  SET bMono:1
ELSE
  SET bMono:0
ENDIF
IF (bMono)
PEN w:0.05cm
  FILL color:white
  SET color_ddeeff:(rgbval("black"))
  SET color_0055bb:(rgbval("black"))
ELSE
  SET color_ddeeff:(rgbval("$ddeeff"))
  SET color_0055bb:(rgbval("$0055bb"))
  # start - smooth shaded colors
  SHADOW off
  CLIP_POLY 3 x1:-.7cm y1:.7cm x2:.7cm y2:.7cm x3:0cm y3:-.7cm
  GRADIENT_RECT x:-.7cm y:-.7cm w:1.4cm h:1.4cm style:downdiag color1:$3399ff
color2:$0055bb
  CLIP_OFF
  PEN w:0.08cm color:$0044aa join:miter
  FILL style:null
  # end - smooth shaded colors
ENDIF
POLYGON 3 x1:-.7cm y1:.7cm x2:.7cm y2:.7cm x3:0cm y3:-.7cm
PEN
IF (NOT LEN p)
  PEN w:0.07cm color:(color_0055bb) endcap:flat join:miter style:dash
  LINE x1:-0.35cm y1:0.55cm x2:0.45cm y2:0.55cm
  PEN w:0.07cm color:(color_0055bb) endcap:flat join:miter
  POLYLINE 3 x1:0.3cm y1:0.37cm x2:0.45cm y2:0.52cm x3:0.3cm y3:0.67cm
```

```

PEN w:0.07cm color:(color_ddeeff) endcap:flat join:miter style:dash
LINE x1:-0.4cm y1:0.5cm x2:0.4cm y2:0.5cm
PEN w:0.07cm color:(color_ddeeff) endcap:flat join:miter
POLYLINE 3 x1:0.25cm y1:0.35cm x2:0.4cm y2:0.5cm x3:0.25cm y3:0.65cm
ELSE
PEN w:0.07cm color:(color_0055bb) endcap:flat join:miter
LINE x1:-0.35cm y1:0.55cm x2:0.45cm y2:0.55cm
POLYLINE 3 x1:0.3cm y1:0.37cm x2:0.45cm y2:0.52cm x3:0.3cm y3:0.67cm
PEN w:0.07cm color:(color_ddeeff) endcap:flat join:miter
LINE x1:-0.4cm y1:0.5cm x2:0.4cm y2:0.5cm
POLYLINE 3 x1:0.25cm y1:0.35cm x2:0.4cm y2:0.5cm x3:0.25cm y3:0.65cm
ENDIF
FONT color:(col)
IF (sub = "")
  IF (sp = "English")
    ATTR "Name" y:.8cm w:c:2.8cm h:t
  ELSE
    ATTR "Bezeichnung" y:.8cm w:c:2.8cm h:t
  ENDIF
ELSE
  IF (sp = "English")
    IF (display = "yes")
      ATTR "Name" y:.8cm w:c:2.8cm h:t
      ATTRBOX "Name" y:.8cm w:c:2.8cm h:t
      FONT "Arial" h:8pt bold
      ATTR "Referenced subprocess" y:(texty2 + .1cm) w:c:2.8cm h:t format:"%m"
      FONT
    ELSE
      ATTR "Referenced subprocess" y:.8cm w:c:2.8cm h:t format:"%m"
    ENDIF
  ELSE
    IF (display = "yes")
      ATTR "Bezeichnung" y:.8cm w:c:2.8cm h:t
      ATTRBOX "Bezeichnung" y:.8cm w:c:2.8cm h:t
      FONT "Arial" h:8pt bold
      ATTR "Referenced subprocess" text:(sn) y:(texty2 + .1cm) w:c:2.8cm h:t
      FONT
    ELSE
      ATTR "Referenced subprocess" text:(sn) y:.8cm w:c:2.8cm h:t
    ENDIF
  ENDIF
ENDIF
ENDIF
IF (i > "0")
  FONT "Arial" h:10.0pt bold color:white
  ATTR "Order" x:0.00cm y:0.00cm w:c:1.00cm h:c
ENDIF
AVAL oF:"Open questions"
IF (
  LEN(replall(replall((oF), " ", ""), "
", ""))>0
)
  IF (bMono)
    FONT "Arial" h:10.0pt bold color:black
  ELSE
    FONT "Arial" h:10.0pt bold color:red
  ENDIF
  TEXT "?" x:0.55cm y:-0.50cm
ENDIF
ENDIF

```

1.1.7 Class "Activity"

ADONIS BPMS BP Library 3.9:

```

GRAPHREP
SHADOW off
AVAL b_visRefAppl:"Visualise referenced IT system elements"
AVAL s_refAppl:"Referenced IT system elements"
AVAL set-default:"no" mono:"Monochrome view"
IF (mono = "yes")
  SET bMono:1
ELSE
  SET bMono:0
ENDIF
AVAL sp:"Language"
IF (sp = "System")
  IF (_uilang = "de")
    SET sp:"German"
  ELSE
    SET sp:"English"
  ENDIF
ENDIF
AVAL rr:"Responsible role"
AVAL set-default:"@" ext:"External documentation"
AVAL refDoc:"Referenced documents"
AVAL indok:"Input"
AVAL outdok:"Output"
AVAL col:"fontcolor"
AVAL refAnw:"Referenced use cases"
# initial width for displaying ref. applications
SET cm_widthRefAppl:2.8cm
PEN w:0.05cm
IF (bMono)
  FILL color:white
  SET color_red:(rgbval("black"))
  SET color_lightskyblue:(rgbval("white"))
  SET color_pen:(rgbval("black"))
ELSE
  FILL color:dodgerblue
  SET color_red:(rgbval("red"))
  SET color_lightskyblue:(rgbval("lightskyblue"))
  SET color_pen:(rgbval("$0044aa"))
  SHADOW off
  GRADIENT_RECT x:-1.4cm y:-.7cm w:2.8cm h:1.4cm style:downdiag color1:$3399ff
  color2:$0055bb
  PEN w:0.08cm color:(color_pen)
  FILL style:null
ENDIF
RECTANGLE x:-1.4cm y:-.7cm w:2.8cm h:1.4cm
PEN
FONT color:(col)
IF (sp = "English")
  ATTRBOX "Name" line-break:words x:0cm y:.8cm w:c:2.8cm h:t line-height:.4cm
  ATTR "Name" line-break:words x:0cm y:.8cm w:c:2.8cm h:t line-height:.4cm
ELSE
  ATTRBOX "Bezeichnung" line-break:words x:0cm y:.8cm w:c:2.8cm h:t line-
  height:.4cm
  ATTR "Bezeichnung" line-break:words x:0cm y:.8cm w:c:2.8cm h:t line-height:.4cm
ENDIF
AVAL show_navigation:"Reference overview active"
IF (show_navigation = "1")

```

```

AVAL show_products:"Products"
AVAL show_respRole:"Responsible role (Mod.Attr.)"
AVAL show_inout:"Input/Output"
AVAL show_usecase:"Use cases"
AVAL show_itsysteme:"IT systems"
AVAL show_demiraci:"RACI/DEMI visibility"
AVAL modDirection:"Modeling direction"
SET cmX:0.0cm
SET cmY:0.0cm
SET cmDisplayWidth:1.25cm
SET cmDisplayWidth2:1.95cm
SET cmDisplayHeight:1.4cm
SET cmDisplayHeight2:2.8cm
SET cmLaneSize:1.3cm
SET cmLaneSize2:2.0cm
IF (modDirection = "vertical")
#-----
# Vertical navigation overview
#-----
SET cmX:0.08cm
SET cmY:-0.75cm
FONT "Arial" h:8pt color:black
PEN color:darkgray outline
# product lane
IF (show_products = "1")
ATTR "Referenced products" format:"%o" x:abs:(cmX) y:(cmY)
w:l:(cmDisplayWidth) h:t:(cmDisplayHeight) line-break:rigorous
SET cmX:(cmX + cmLaneSize)
ENDIF
# demi/raci lane
IF (show_demiraci = "1")
ATTR "Responsible for execution" format:"%o" x:abs:(cmX) y:(cmY)
w:l:(cmDisplayWidth) h:t:(cmDisplayHeight) line-break:rigorous
SET cmX:(cmX + cmLaneSize)
ATTR "Accountable for approving results" format:"%o" x:abs:(cmX) y:(cmY)
w:l:(cmDisplayWidth) h:t:(cmDisplayHeight) line-break:rigorous
SET cmX:(cmX + cmLaneSize)
ATTR "Cooperation/participation" format:"%o" x:abs:(cmX) y:(cmY)
w:l:(cmDisplayWidth) h:t:(cmDisplayHeight) line-break:rigorous
SET cmX:(cmX + cmLaneSize)
ATTR "To inform" format:"%o" x:abs:(cmX) y:(cmY)
w:l:(cmDisplayWidth) h:t:(cmDisplayHeight) line-break:rigorous
SET cmX:(cmX + cmLaneSize)
ENDIF
# responsible role lane
IF (show_respRole = "1")
ATTR "Responsible role" format:"%o" x:abs:(cmX) y:(cmY)
w:l:(cmDisplayWidth) h:t:(cmDisplayHeight) line-break:rigorous
SET cmX:(cmX + cmLaneSize)
ENDIF
# input/output lane
IF (show_inout = "1")
ATTR "Input" format:"%o" x:abs:(cmX) y:(cmY)
w:l:(cmDisplayWidth2) h:t:(cmDisplayHeight) line-break:rigorous
SET cmX:(cmX + cmLaneSize2)
ATTR "Output" format:"%o" x:abs:(cmX) y:(cmY)
w:l:(cmDisplayWidth2) h:t:(cmDisplayHeight) line-break:rigorous
SET cmX:(cmX + cmLaneSize2)
ENDIF
# use case lane
IF (show_usecase = "1")

```

Part IV

```
        ATTR      "Referenced use cases"      format:"%o"      x:abs:(cmX)      y:(cmY)
w:l:(cmDisplayWidth) h:t:(cmDisplayHeight) line-break:rigorous
        SET cmX:(cmX + cmLaneSize)
ENDIF
# application lane
IF (show_itsysteme = "1")
    ATTR      "Referenced IT system elements"      format:"%o"      x:abs:(cmX)      y:(cmY)
w:l:(cmDisplayWidth) h:t:(cmDisplayHeight) line-break:rigorous
    SET cmX:(cmX + cmLaneSize)
ENDIF
ELSIF (modDirection = "horizontal")
#-----
# Horizontal navigation overview
#-----
SET cmX:-1.35cm
SET cmY:0.58cm
FONT "Arial" h:8pt color:black
PEN color:darkgray outline
# product lane
IF (show_products = "1")
    ATTR      "Referenced products"              format:"%o"      x:(cmX)      y:abs:(cmY)
w:l:(cmDisplayHeight2) h:t:(cmDisplayWidth) line-break:rigorous
    SET cmY:(cmY + cmLaneSize)
ENDIF
# demi/raci lane
IF (show_demiraci = "1")
    ATTR      "Responsible for execution"      format:"%o"      x:(cmX)      y:abs:(cmY)
w:l:(cmDisplayHeight2) h:t:(cmDisplayWidth) line-break:rigorous
    SET cmY:(cmY + cmLaneSize)
    ATTR      "Accountable for approving results"      format:"%o"      x:(cmX)      y:abs:(cmY)
w:l:(cmDisplayHeight2) h:t:(cmDisplayWidth) line-break:rigorous
    SET cmY:(cmY + cmLaneSize)
    ATTR      "Cooperation/participation"      format:"%o"      x:(cmX)      y:abs:(cmY)
w:l:(cmDisplayHeight2) h:t:(cmDisplayWidth) line-break:rigorous
    SET cmY:(cmY + cmLaneSize)
    ATTR      "To inform"                      format:"%o"      x:(cmX)      y:abs:(cmY)
w:l:(cmDisplayHeight2) h:t:(cmDisplayWidth) line-break:rigorous
    SET cmY:(cmY + cmLaneSize)
ENDIF
# responsible role lane
IF (show_respRole = "1")
    ATTR      "Responsible role"              format:"%o"      x:(cmX)      y:abs:(cmY)
w:l:(cmDisplayHeight2) h:t:(cmDisplayWidth) line-break:rigorous
    SET cmY:(cmY + cmLaneSize)
ENDIF
# input/output lane
IF (show_inout = "1")
    ATTR      "Input"                          format:"%o"      x:(cmX)      y:abs:(cmY)
w:l:(cmDisplayHeight2) h:t:(cmDisplayWidth) line-break:rigorous
    SET cmY:(cmY + cmLaneSize2)
    ATTR      "Output"                        format:"%o"      x:(cmX)      y:abs:(cmY)
w:l:(cmDisplayHeight2) h:t:(cmDisplayWidth) line-break:rigorous
    SET cmY:(cmY + cmLaneSize2)
ENDIF
# use case lane
IF (show_usecase = "1")
    ATTR      "Referenced use cases"      format:"%o"      x:(cmX)      y:abs:(cmY)
w:l:(cmDisplayHeight2) h:t:(cmDisplayWidth) line-break:rigorous
    SET cmY:(cmY + cmLaneSize)
ENDIF
# application lane
```

```

    IF (show_itsysteme = "1")
        ATTR "Referenced IT system elements" format:"%o" x:(cmX) y:abs:(cmY)
w:l:(cmDisplayHeight2) h:t:(cmDisplayWidth) line-break:rigorous
        SET cmY:(cmY + cmLaneSize)
    ENDIF
ENDIF
ENDIF
FONT color:(col)
#-----
# END RACI/DEMI
#-----
AVAL k:"Classification"
IF (search(k,"manual",0) >=0 AND LEN(k)=8)
    FONT "Wingdings" h:20pt color:whitesmoke
    TEXT "?" x:-1.35cm y:-.80cm
ELSIF (search(k,"automatic",0) >=0 AND LEN(k)=11)
    FONT "Wingdings" h:18pt color:whitesmoke
    TEXT ":" x:-1.35cm y:-.65cm
ELSIF (search(k,"semi-automatic",0) >=0 AND LEN(k)=17)
    FONT "Wingdings" h:14pt color:whitesmoke
    TEXT "?" x:-1.15cm y:-.80cm
    FONT "Wingdings" h:13pt color:whitesmoke
    TEXT ":" x:-1.35cm y:-.55cm
ELSIF (search(k,"planning",0) >=0 AND LEN(k)=10)
    FONT "Webdings" h:18pt color:whitesmoke
    TEXT "?" x:-1.35cm y:-.65cm
ELSIF (search(k,"checking",0) >=0 AND LEN(k)=10)
    FONT "Webdings" h:20pt color:whitesmoke
    TEXT "N" x:-1.35cm y:-.70cm
ELSIF (search(k,"administrating",0) >=0 AND LEN(k)=16)
    FONT "Wingdings" h:16pt color:whitesmoke
    TEXT "1" x:-1.35cm y:-.65cm
ELSIF (search(k,"executing",0) >=0 AND LEN(k)=11)
    FONT "Webdings" h:18pt color:whitesmoke
    TEXT "@" x:-1.35cm y:-.65cm
ELSIF (search(k,"value adding",0) >=0 AND LEN(k)=14)
    FONT "Arial" h:14pt color:whitesmoke
    TEXT "$$" x:-1.30cm y:-.65cm
ELSIF (search(k,"communicating",0) >=0 AND LEN(k)=15)
    FONT "Wingdings" h:18pt color:whitesmoke
    TEXT "(" x:-1.35cm y:-.65cm
ELSIF (search(k,"external",0) >=0 AND LEN(k)=10)
    FONT "Webdings" h:16pt color:whitesmoke
    TEXT "ü" x:-1.30cm y:-.65cm
ELSIF (search(k,"manual",0) >=0 AND search(k,"automatic",0) >=0)
    FONT "Webdings" h:18pt color:whitesmoke
    TEXT "+" x:-1.35cm y:-.72cm
    FONT "Arial" h:7pt color:whitesmoke
    TEXT "Error" x:-1.35cm y:-.26cm
ENDIF
AVAL oF:"Open questions"
IF ( LEN(replall(replall((oF)," ",""),"
",""))>0 )
    FONT "Arial" h:10.0pt bold color:(color_red)
    TEXT "?" x:1.20cm y:-1.10cm
    SET cm_widthRefAppl:2.55cm
    IF ( token(ext, 1, "@") != " " )
        SET cm_widthRefAppl:1.9cm
        FONT "Wingdings" h:18.0pt color:(col)
        TEXT "4" x:1.1cm y:-.64cm w:r h:b
    
```

Part IV

```
HOTSPOT "External documentation" x:0.55cm y:-1.35cm w:0.5cm h:0.6cm
text:(replall(token(ext, 1, "@"), "\", ""))
ELSE
  IF ( refDoc != "" )
    SET cm_widthRefAppl:1.9cm
    FONT "Wingdings" h:18.0pt color:(col)
    TEXT "4" x:1.1cm y:-.64cm w:r h:b
    HOTSPOT "Referenced documents" x:0.55cm y:-1.35cm w:0.5cm h:0.6cm
  ENDIF
ENDIF
ELSE
  IF ( token(ext, 1, "@") != "" )
    SET cm_widthRefAppl:2.3cm
    FONT "Wingdings" h:18.0pt color:(col)
    TEXT "4" x:1.5cm y:-.64cm w:r h:b
    HOTSPOT "External documentation" x:0.9cm y:-1.35cm w:0.5cm h:0.6cm
text:(replall(token(ext, 1, "@"), "\", ""))
ELSE
  IF ( refDoc != "" )
    SET cm_widthRefAppl:2.3cm
    FONT "Wingdings" h:18.0pt color:(col)
    TEXT "4" x:1.5cm y:-.64cm w:r h:b
    HOTSPOT "Referenced documents" x:0.9cm y:-1.35cm w:0.5cm h:0.6cm
  ENDIF
ENDIF
ENDIF
SET order_ypos:0cm
AVAL set-default:"" vRv:"Display responsible role"
AVAL set-default:"" vR:"Responsible role"
AVAL set-default:"" eD:"Done by"
IF (vRv = "Yes")
  PEN style:null
  IF (vR != "")
    SHADOW off
    FILL color:(color_lightskyblue)
    RECTANGLE x:-1.36cm y:0.0cm w:2.72cm h:.66cm
    FONT "Arial" h:8pt
    IF (sp = "English")
      ATTR "Responsible role" line-break:rigorous y:0.35cm w:c:2.8cm h:c:.7cm format:"%o"
    ELSE
      ATTR "Responsible role" text:(rr) line-break:rigorous y:0.35cm w:c:2.8cm
h:c:.7cm format:"%o"
    ENDIF
  SET order_ypos:-0.25cm
  PEN style:null
  FILL style:null
  #HOTSPOT "Responsible role" x:-1.8cm y:.2cm w:.3cm h:.3cm
  PEN
  FILL
ELSIF (eD != "")
  SHADOW off
  FILL color:(color_lightskyblue)
  RECTANGLE x:-1.36cm y:0.0cm w:2.72cm h:.66cm
  FONT "Arial" h:8pt
  IF (sp = "English")
    ATTR "Done by" line-break:rigorous y:0.35cm w:c:2.8cm h:c:.7cm
  ELSE
    ATTR "Done by" text:(rr) line-break:rigorous y:0.35cm w:c:2.8cm h:c:.7cm
  ENDIF
  SET order_ypos:-0.25cm
```



```

    PEN style:null
    FILL style:null
    PEN
    FILL
  ENDIF
ENDIF
AVAL i:"Order"
IF (i > "0")
  FONT "Arial" h:10.0pt bold color:white
  ATTR "Order" w:c:1cm h:c y:(order_ypos)
ENDIF
FILL color:white
SHADOW off
IF (refAnw <> "")
  ELLIPSE x:-1.7cm y:-.55cm rx:.2cm ry:.1cm
  HOTSPOT "Referenced use cases" x:-1.9cm y:-0.65cm w:0.4cm h:0.2cm
ENDIF
#-----
# Input/Output Pfeile
#-----
FONT "Arial" h:7.0pt color:(col)
IF ((b_visRefAppl = "1") AND (s_refAppl != ""))
  ATTR "Referenced IT system elements" format:"%o" x:-1.4cm y:-0.72cm
w:l:(cm_widthRefAppl) h:b:1.5cm line-height:9pt line-break:rigorous
  IF (outdok != "")
    SET mX:-1.55cm
    FONT "Wingdings" h:9.0pt color:(col)
    TEXT "é" x:(mX) y:-.9cm w:c h:c
    HOTSPOT "Output" x:(mX-0.05cm) y:-1cm w:0.1cm h:0.2cm
  ENDIF
  IF (indok != "")
    IF (outdok != "")
      SET mX:-1.80cm
    ELSE
      SET mX:-1.55cm
    ENDIF
    FONT "Wingdings" h:9.0pt color:(col)
    TEXT "ê" x:(mX) y:-.84cm w:c h:c
    HOTSPOT "Input" x:(mX-0.05cm) y:-1cm w:0.1cm h:0.2cm
  ENDIF
ELSE
  IF (indok != "")
    FONT "Wingdings" h:9.0pt color:(col)
    TEXT "ê" x:-1.3cm y:-.84cm w:c h:c
    HOTSPOT "Input" x:-1.35cm y:-1cm w:0.1cm h:0.2cm
  ENDIF
  IF (outdok != "")
    IF (indok != "")
      SET mX:-1.03cm
    ELSE
      SET mX:-1.3cm
    ENDIF
    FONT "Wingdings" h:9.0pt color:(col)
    TEXT "é" x:(mX) y:-.9cm w:c h:c
    HOTSPOT "Output" x:(mX-0.05cm) y:-1cm w:0.1cm h:0.2cm
  ENDIF
ENDIF
FILL style:null
PEN w:0.08cm color:(color_pen)
RECTANGLE x:-1.4cm y:-.7cm w:2.8cm h:1.4cm

```

1.1.8 Class "Decision"

ADONIS BPMS BP Library 3.9:

```

GRAPHREP
SHADOW off
AVAL sp:"Language"
IF (sp = "System")
  IF (_uilang = "de")
    SET sp:"German"
  ELSE
    SET sp:"English"
  ENDIF
ENDIF
AVAL set-default:"1" su:"Sum"
AVAL col:"fontcolor"
AVAL vis:"display incorrect transition probability"
AVAL set-default:"no" mono:"Monochrome view"
IF (mono = "yes")
  SET bMono:1
ELSE
  SET bMono:0
ENDIF
PEN w:0.05cm
IF (bMono)
  FILL color:white
  SET color_red:(rgbval("black"))
ELSE
  FILL color:yellow
  SET color_red:(rgbval("red"))
  SHADOW off
  CLIP_POLY 4 x1:-1cm y2:.7cm x3:1cm y4:-.7cm
  GRADIENT_RECT x:-1cm y:-.7cm w:2cm h:1.4cm style:downdiag color1:$ffff66
  color2:$eeee00
  CLIP_OFF
  PEN w:0.08cm color:$888800 join:miter
  FILL style:null
ENDIF
POLYGON 4 x1:-1cm y2:.7cm x3:1cm y4:-.7cm
PEN
FONT color:(col)
IF (sp = "English")
  ATTR "Name" y:.8cm w:c:2.8cm h:t
ELSE
  ATTR "Bezeichnung" y:.8cm w:c:2.8cm h:t
ENDIF
AVAL i:"Order"
IF (i > "0")
  FONT "Arial" h:10.0pt bold color:black
  ATTR "Order" w:c:1.00cm h:c
ENDIF
AVAL oF:"Open questions"
IF (LEN(replall(replall((oF), " ", ""), "", "")) > 0)
  FONT "Arial" h:10.0pt bold color:(color_red)
  TEXT "?" x:0.60cm y:-.60cm h:c
ENDIF
IF ((VAL (replall (su, ",", ".")) <> 1) AND
  (vis = "yes"))
  FONT "Arial" h:10.0pt bold color:(color_red)
  TEXT "!" x:1.0cm y:-.60cm h:c
ENDIF

```

1.1.9 Class "Parallellity"

ADONIS BPMS BP Library 3.9:

```

GRAPHREP
SHADOW off
AVAL sp:"Language"
IF (sp = "System")
  IF (_uilang = "de")
    SET sp:"German"
  ELSE
    SET sp:"English"
  ENDIF
ENDIF
AVAL mr_local:"Modeling direction"
AVAL mr:"Modeling direction (Model)"
# if local modeling direction is undefined, then take modeling direction of the
current model
IF (mr_local = "from left to right")
  SET mr:"horizontal"
ELSIF (mr_local = "up to down")
  SET mr:"vertical"
ENDIF
AVAL d:"Representation"
AVAL i:"Order"
AVAL col:"fontcolor"
AVAL set-default:"no" mono:"Monochrome view"
IF (mono = "yes")
  SET bMono:1
ELSE
  SET bMono:0
ENDIF
PEN w:0.05cm
IF (bMono)
  FILL color:white
  SET colorRed:(rgbval("black"))
ELSE
  FILL color:yellow
  SET colorRed:(rgbval("red"))
  PEN w:0.08cm color:$888800 join:miter
ENDIF
IF (mr = "vertical")
  POLYGON 3 x1:0cm y1:-.35cm x2:-.7cm y2:.35cm x3:.7cm y3:.35cm
ELSE
  POLYGON 3 x1:-.4cm x2:.3cm y2:.7cm x3:.3cm y3:-.7cm
ENDIF
IF (d = "with name")
  FONT color:(col)
  IF (mr ="horizontal")
    IF (sp = "English")
      ATTR "Name" y:.8cm w:c:1.00cm h:t
    ELSE
      ATTR "Bezeichnung" y:.8cm w:c:1.00cm h:t
    ENDIF
  ELSE
    IF (sp = "English")
      ATTR "Name" y:.45cm w:c:1.00cm h:t
    ELSE
      ATTR "Bezeichnung" y:.45cm w:c:1.00cm h:t
    ENDIF
  ENDIF
ENDIF

```

Part IV

```
ENDIF
IF (i > "0")
  FONT "Arial" h:10.0pt bold color:(col)
  IF (mr ="horizontal")
    ATTR "Order" w:c:1.00cm h:c
  ELSE
    ATTR "Order" y:.05cm w:c:1.00cm h:c
  ENDIF
ENDIF
ENDIF
```

1.1.10 Class "Merging"

ADONIS BPMS BP Library 3.9:

```
GRAPHREP
SHADOW off
AVAL sp:"Language"
IF (sp = "System")
  IF (_uilang = "de")
    SET sp:"German"
  ELSE
    SET sp:"English"
  ENDIF
ENDIF
AVAL mr_local:"Modeling direction"
AVAL mr:"Modeling direction (Model)"
# if local modeling direction is undefined, then take modeling direction of the
current model
IF (mr_local = "from left to right")
  SET mr:"horizontal"
ELSIF (mr_local = "up to down")
  SET mr:"vertical"
ENDIF
AVAL d:"Representation"
AVAL i:"Order"
AVAL col:"fontcolor"
AVAL set-default:"no" mono:"Monochrome view"
IF (mono = "yes")
  SET bMono:1
ELSE
  SET bMono:0
ENDIF
IF (bMono)
  FILL color:white
PEN w:0.05cm
ELSE
  FILL color:yellow
  PEN w:0.08cm color:$888800 join:miter
ENDIF
IF (mr = "vertical")
  POLYGON 3 x1:-.7cm y1:-.35cm x2:0cm y2:.35cm x3:.7cm y3:-.35cm
ELSE
  POLYGON 3 x1:.4cm y1:0cm x2:-.3cm y2:.7cm x3:-.3cm y3:-.7cm
ENDIF
IF (d = "with name")
  FONT color:(col)
  IF (mr = "horizontal")
    IF (sp = "English")
      ATTR "Name" y:.8cm w:c:1.00cm h:t
```

```

ELSE
  ATTR "Bezeichnung" y:.8cm w:c:1.00cm h:t
ENDIF
ELSE
  IF (sp = "English")
    ATTR "Name" y:.45cm w:c:1.00cm h:t
  ELSE
    ATTR "Bezeichnung" y:.45cm w:c:1.00cm h:t
  ENDIF
ENDIF
ENDIF
ENDIF
IF (i > "0")
  FONT "Arial" h:10.0pt bold color:(col)
  IF (mr = "horizontal")
    ATTR "Order" x:0.00cm y:0.00cm w:c:1.00cm h:c
  ELSE
    ATTR "Order" y:-.05cm w:c:1.00cm h:c
  ENDIF
ENDIF
ENDIF

```

1.1.11 Class "End"

ADONIS BPMS BP Library 3.9:

```

GRAPHREP
SHADOW off
AVAL sp:"Language"
IF (sp = "System")
  IF (_uilang = "de")
    SET sp:"German"
  ELSE
    SET sp:"English"
  ENDIF
ENDIF
AVAL t:"Type"
AVAL i:"Order"
AVAL d:"Representation"
AVAL col:"fontcolor"
AVAL set-default:"no" mono:"Monochrome view"
IF (mono = "yes")
  SET bMono:1
ELSE
  SET bMono:0
ENDIF
IF (bMono)
  FILL color:white
PEN w:0.05cm
ELSE
  FILL color:yellow
  SHADOW off
  CLIP_ELLIPSE rx:.7cm ry:.7cm
  GRADIENT_RECT x:-.7cm y:-.7cm w:1.4cm h:1.4cm style:downdiag color1:$ffff66
  color2:$eeee00
  CLIP_OFF
  PEN w:0.08cm color:$888800
  FILL style:null
ENDIF
ELLIPSE rx:.7cm ry:.7cm
PEN

```

Part IV

```
IF (t="global")
  FILL style:null
  ELLIPSE rx:.6cm ry:.6cm
ENDIF
IF (d = "with name")
  FONT color:(col)
  IF (sp = "English")
    ATTR "Name" y:.8cm w:c:1.00cm h:t
  ELSE
    ATTR "Bezeichnung" y:.8cm w:c:1.00cm h:t
  ENDIF
ENDIF
IF (i > "0")
  FONT "Arial" h:10.0pt bold color:black
  ATTR "Order" x:0.00cm y:0.00cm w:c:1.00cm h:c
ENDIF
```

1.1.12 Class "Variable"

ADONIS BPMS BP Library 3.9:

```
GRAPHREP
AVAL sp:"Language"
IF (sp = "System")
  IF (_uilang = "de")
    SET sp:"German"
  ELSE
    SET sp:"English"
  ENDIF
ENDIF
AVAL t:"Variable scope"
AVAL col:"fontcolor"
FONT color:(col)
AVAL set-default:"no" mono:"Monochrome view"
IF (mono = "yes")
  SET bMono:1
ELSE
  SET bMono:0
ENDIF
IF (bMono)
  FILL color:white
  PEN w:0.05cm
ELSE
  SHADOW off
  PEN w:0.08cm color:$00aa55
  CLIP_ELLIPSE rx:0.70cm ry:0.70cm
  GRADIENT_RECT x:-.7cm y:-.7cm w:1.4cm h:1.4cm style:downdiag color1:$33ff99
  color2:$00dd77
  POLYGON 6 x1:0cm y1:0.35cm x2:0.55cm y2:-0.9cm x3:0.55cm y3:-0.4cm x4:0cm
  y4:0.85cm x5:-0.55cm y5:-0.4cm x6:-0.55cm y6:-0.9cm
  CLIP_OFF
  FILL style:null
ENDIF
ELLIPSE rx:0.70cm ry:0.70cm
IF (sp = "English")
  ATTR "Name" y:0.8cm w:c:1.4cm h:t
ELSE
  ATTR "Bezeichnung" y:0.8cm w:c:1.4cm h:t
ENDIF
```

```

IF (t = "global")
  ELLIPSE rx:0.6cm ry:0.6cm
ENDIF
IF (bMono)
  FONT "Arial" h:32pt color:black
  TEXT "V" y:0.13cm w:c h:c
ENDIF

```

1.1.13 Class "Random generator"

ADONIS BPMS BP Library 3.9:

```

GRAPHREP
AVAL set-default:"Normal" w:"Value"
AVAL set-default:"No" m:"Manual random generator"
AVAL col:"fontcolor"
AVAL set-default:"no" mono:"Monochrome view"
IF (mono = "yes")
  SET bMono:1
ELSE
  SET bMono:0
ENDIF
IF (bMono)
  FILL color:white
  PEN w:0.05cm
ELSE
  SHADOW off
  CLIP_ELLIPSE rx:.7cm ry:.7cm
FILL color:mediumspringgreen
GRADIENT_RECT x:-.7cm y:-.7cm w:1.4cm h:1.4cm style:downdiag color1:$33ff99
color2:$00dd77
CLIP_OFF
FILL style:null
PEN w:0.08cm color:$00aa55
ENDIF
ELLIPSE rx:.7cm ry:.7cm
PEN w:0.025cm
SHADOW mode:off
IF (bMono)
  FILL color:white
ELSE
  FILL color:mediumseagreen
ENDIF
AVAL sp:"Language"
IF (sp = "System")
  IF (_uilang = "de")
    SET sp:"German"
  ELSE
    SET sp:"English"
  ENDIF
ENDIF
FONT color:(col)
IF (sp = "English")
  ATTR "Value" y:.8cm w:c:2.8cm h:t
ELSE
  ATTR "Info zum Wert der Variablenbelegung" y:.8cm w:c:2.8cm h:t
ENDIF
IF (search (w, "Discrete", 0) >= 0)

```

Part IV

```
POLYLINE 7 x1:-.3cm y1:.3cm x2:-.3cm y2:.1cm x3:-.1cm y3:.1cm x4:-.1cm y4:-.2cm
x5:.2cm y5:-.2cm x6:.2cm y6:-.3cm x7:.5cm y7:-.3cm
LINE x1:-.5cm y1:.3cm x2:.5cm y2:.3cm
LINE x1:0cm y1:-.4cm x2:0cm y2:.4cm
ELSIF (search (w, "Exponential", 0) >= 0)
  COMPOUND 2
  CURVE "t" fx:(t) fy:(-.6*exp(-(3.8*(t+.4)))+.3) from:-.4 to:.5
  LINE x1:.5cm y1:.3cm x2:-.4cm y2:.3cm
  LINE x1:-.5cm y1:.3cm x2:-.4cm y2:.3cm
  LINE x1:-.4cm y1:.4cm x2:-.4cm y2:-.4cm
ELSIF (search (w, "Uniform",0) >= 0 )
  RECTANGLE x:-.3cm y:-.1cm w:.7cm h:.4cm
  LINE x1:-.5cm y1:.3cm x2:.5cm y2:.3cm
  LINE x1:0cm y1:-.4cm x2:0cm y2:.4cm
ELSIF (search (w, "Normal", 0) >= 0)
  COMPOUND 1
  CURVE "t" fx:(t) fy:(-.7*exp(-14*t*t)+.2) from:-.6 to:.6
  LINE x1:0cm y1:-.6cm x2:0cm y2:.3cm
ELSE
  FONT "Arial" h:16pt
  TEXT "=" x:-0.50cm y:0.03cm w:1 h:c
  FONT "Arial" h:16pt italic
  TEXT "f" x:-0.15cm y:0.03cm w:1 h:c
  FONT "Arial" h:16pt
  TEXT "( )" x:0.09cm y:0.03cm w:1 h:c
ENDIF
IF (m = "Yes")
  IF (bMono)
    FONT "Wingdings" h:16pt color:black
  ELSE
    FONT "Wingdings" h:16pt color:crimson
  ENDIF
  TEXT "I" y:-.9cm x:-.9cm
ENDIF
```

1.1.14 Class "Resource"

ADONIS BPMS BP Library 3.9:

```
GRAPHREP layer:2
SHADOW off
AVAL sp:"Language"
IF (sp = "System")
  IF (_uilang = "de")
    SET sp:"German"
  ELSE
    SET sp:"English"
  ENDIF
ENDIF
AVAL set-default:"EDP system" rt:"Type of resource"
AVAL col:"fontcolor"
AVAL set-default:"no" mono:"Monochrome view"
AVAL str_bitmap:"Screenshot"
IF (mono = "yes")
  SET bMono:1
ELSE
  SET bMono:0
ENDIF
PEN w:0.05cm
```



```

IF (bMono)
  SET color_lightskyblue:(rgbval("white"))
  SET color_navy:(rgbval("black"))
  SET color_lightgreen:(rgbval("white"))
  SET color_palegreen:(rgbval("white"))
  SET color_orangered:(rgbval("white"))
  SET color_mistyrose:(rgbval("white"))
  SET color_forestgreen:(rgbval("white"))
  SET color_lightsteelblue:(rgbval("white"))
  SET col:(rgbval("black"))
ELSE
  SET color_lightskyblue:(rgbval("lightskyblue"))
  SET color_navy:(rgbval("navy"))
  SET color_lightgreen:(rgbval("lightgreen"))
  SET color_palegreen:(rgbval("palegreen"))
  SET color_orangered:(rgbval("orangered"))
  SET color_mistyrose:(rgbval("mistyrose"))
  SET color_forestgreen:(rgbval("forestgreen"))
  SET color_lightsteelblue:(rgbval("lightsteelblue"))
ENDIF
IF (token(str_bitmap, 1, "@") != "")
  SET cms_width:2.8cm
  SET cms_height:1.94cm
  SET str_bitmap:(token(str_bitmap, 1, "@"))
  BITMAPINFO (str_bitmap) # get the bitmap size
  STRETCH off
  IF (bmpwidth / CMS cms_width < bmpheight / CMS cms_height)
    # use maximum height, space left and right
    SET w:(cms_height * (bmpwidth / bmpheight))
    BITMAP (str_bitmap) x:((0cm - w) / 2) y:((-0.4cm - cms_height) / 2) w:(w)
h:(cms_height)
  ELSE
    # use maximum width, space at top and bottom
    SET h:(cms_width * (bmpheight / bmpwidth))
    BITMAP (str_bitmap) x:((0.0cm - cms_width) / 2) y:((0.3cm - h) / 2)
w:(cms_width) h:(h)
  ENDIF
ELSE
IF (rt = "EDP system")
  FILL color:lightgray
  IF (NOT bMono)
    # start - smooth shaded colors
    CLIP_RECT x:-.6cm y:-.7cm w:1.2cm h:1.05cm
    GRADIENT_RECT x:-.6cm y:-.7cm w:1.2cm h:1.05cm style:updiag
      color1:white color2:lightgray
    FILL style:null
    PEN w:0.08cm color:$6b6b6b join:miter
    CLIP_OFF
    # end - smooth shaded colors
  ENDIF
RECTANGLE x:-.6cm y:-.7cm w:1.2cm h:1.05cm
  IF (NOT bMono)
    # start - smooth shaded colors
    CLIP_RECT x:-.7cm y:.35cm w:1.4cm h:.35cm
    GRADIENT_RECT x:-.7cm y:.35cm w:1.4cm h:.35cm style:updiag
      color1:white color2:lightgray
    PEN w:0.08cm color:$6b6b6b join:miter
    FILL style:null
    CLIP_OFF
    # end - smooth shaded colors
  ENDIF

```

Part IV

```
RECTANGLE x:-.7cm y:.35cm w:1.4cm h:.35cm
  FILL color:(color_lightskyblue)
  # start - smooth shaded colors
  CLIP_RECT x:-.45cm y:-.55cm w:.9cm h:.75cm
  GRADIENT_RECT x:-.45cm y:-.55cm w:.9cm h:.75cm style:updiag
    color1:white color2:(color_lightskyblue)
  PEN w:0.05cm
  FILL style:null
  CLIP_OFF
  # end - smooth shaded colors
RECTANGLE x:-.45cm y:-.55cm w:.9cm h:.75cm
  FILL color:(color_navy)
RECTANGLE x:-.3cm y:-.45cm w:.4cm h:.05cm
  FILL color:white
RECTANGLE x:-.3cm y:-.4cm w:.4cm h:.2cm
  FILL color:(color_navy)
RECTANGLE x:-.1cm y:-.15cm w:.4cm h:.05cm
  FILL color:white
RECTANGLE x:-.1cm y:-.1cm w:.4cm h:.2cm
  FILL color:(color_lightgreen)
RECTANGLE x:-.57cm y:.48cm w:.09cm h:.09cm
  FILL color:black
RECTANGLE x:.15cm y:.48cm w:.45cm h:.03cm
ELSIF (rt = "Communication system")
  FILL color:slategray
  IF (NOT bMono)
    # start - smooth shaded colors
    CLIP_RECT x:-.275cm y:-.7cm w:.55cm h:1.4cm
    GRADIENT_RECT x:-.275cm y:-.7cm w:.55cm h:1.4cm style:updiag
      color1:white color2:gray
    PEN w:0.08cm color:$484848 join:miter
    FILL style:null
    CLIP_OFF
    # end - smooth shaded colors
  ENDIF
RECTANGLE x:-.275cm y:-.7cm w:.55cm h:1.4cm
  FILL color:black
RECTANGLE x:.14cm y:-1cm w:.05cm h:.3cm
  PEN w:0.05cm
  FILL color:(color_palegreen)
RECTANGLE x:-.225cm y:-.55cm w:.45cm h:.3cm
  FILL color:black
RECTANGLE x:-.20cm y:-.15cm w:.075cm h:.05cm
RECTANGLE x:-.05cm y:-.15cm w:.075cm h:.05cm
RECTANGLE x:0.10cm y:-.15cm w:.075cm h:.05cm
RECTANGLE x:-.20cm y:-.03cm w:.075cm h:.05cm
RECTANGLE x:-.05cm y:-.03cm w:.075cm h:.05cm
RECTANGLE x:0.10cm y:-.03cm w:.075cm h:.05cm
RECTANGLE x:-.20cm y:0.09cm w:.075cm h:.05cm
RECTANGLE x:-.05cm y:0.09cm w:.075cm h:.05cm
RECTANGLE x:0.10cm y:0.09cm w:.075cm h:.05cm
RECTANGLE x:-.20cm y:0.21cm w:.075cm h:.05cm
RECTANGLE x:-.05cm y:0.21cm w:.075cm h:.05cm
RECTANGLE x:0.10cm y:0.21cm w:.075cm h:.05cm
RECTANGLE x:-.05cm y:.55cm w:.1cm h:.03cm
RECTANGLE x:-.05cm y:-.65cm w:.1cm h:.03cm
ELSE
  FILL color:white
  RECTANGLE x:-0.9cm y:-0.65cm w:1.8cm h:1.3cm
  FILL color:whitesmoke
ENDIF
```

```

ENDIF
FONT color:(col)
IF (sp = "English")
  ATTR "Name" y:.8cm w:c:2.8cm h:t
ELSE
  ATTR "Bezeichnung" y:.8cm w:c:2.8cm h:t
ENDIF

```

1.1.15 Class "Process"

ADONIS BPMS BP Library 3.9:

```

GRAPHREP sizing:asymmetrical
SHADOW off
PEN w:0.03cm
AVAL sp:"Language"
IF (sp = "System")
  IF (_uilang = "de")
    SET sp:"German"
  ELSE
    SET sp:"English"
  ENDIF
ENDIF
AVAL rp:"Referenced process"
AVAL anzeige:"Display name and reference"
AVAL i:"Order"
AVAL col:"fontcolor"
AVAL sn:"Subprocessname"
AVAL eP:"External process"
AVAL set-default:"$0044aa" f:"Color"
AVAL grad:"Font size"
AVAL b_visRefAppl:"Visualise referenced IT system elements"
AVAL s_refAppl:"Referenced IT system elements"
AVAL set-default:"no" mono:"Monochrome view"
IF (mono = "yes")
  SET bMono:1
ELSE
  SET bMono:0
ENDIF
IF (bMono)
  SET color_fill:(rgbval("white"))
  SET color_pen:(rgbval("black"))
  SET color_dodgerblue:(rgbval("white"))
  SET color_yellow:(rgbval("white"))
  SET color_red:(rgbval("black"))
ELSE
  SET color_fill:(rgbval(f))
  SET color_pen:(rgbval(f))
  SET color_dodgerblue:(rgbval("dodgerblue"))
  SET color_yellow:(rgbval("yellow"))
  SET color_red:(rgbval("red"))
ENDIF
# define table (for sizing)
TABLE x:-1.5cm y:-0.7cm w:3.25cm h:1.4cm cols:3 rows:2
  w1:0.2cm w2:100% w3:0.25cm
  h1:50% h2:50%
STRETCH off
FONT color:(col)
IF (eP = "yes")

```

Part IV

```
SET color_fill:(rgbval("white"))
SET color_pen:(rgbval("black"))
PEN color:(color_pen) w:0.05cm style:dash
FILL color:(color_fill)
ELSE
  IF (NOT bMono)
    # start - smooth shaded colors
    CLIP_POLY 6 x1:(tabx0) y1:(taby0) x2:(tabx2) y2:(taby0) x3:(tabx3) x4:(tabx2)
y4:(taby2) x5:(tabx0) y5:(taby2) x6:(tabx1)
    GRADIENT_RECT x:(tabx0) y:(taby0) w:(tabw1 + tabw2 + tabw3) h:(tabh1 + tabh2)
style:downdiag
                color1:white color2:(color_fill)
    PEN w:0.08cm color:(color_pen) join:miter
    FILL style:null
    CLIP_OFF
    # end - smooth shaded colors
  ELSE
    FILL color:(color_fill)
  ENDIF
ENDIF
POLYGON 6 x1:(tabx0) y1:(taby0) x2:(tabx2) y2:(taby0) x3:(tabx3) x4:(tabx2)
y4:(taby2) x5:(tabx0) y5:(taby2) x6:(tabx1)
IF (search(rp,"(Business process model)",0) >= 0)
  FILL color:(color_dodgerblue)
  RECTANGLE x:-0.27cm y:-.25cm w:1cm h:.5cm
  FILL color:(color_yellow)
  POLYGON 3 x1:-1.1cm y1:.25cm x2:-.85cm y2:-.25cm x3:-.6cm y3:.25cm
  ELLIPSE x:1.3cm rx:.25cm ry:.25cm
  LINE x1:.73cm x2:1.05cm
  LINE x1:.95cm y1:.06cm x2:1.05cm
  LINE x1:.95cm y1:-.06cm x2:1.05cm
  LINE x1:-.72cm x2:-.27cm
  LINE x1:-.37cm y1:.06cm x2:-.27cm
  LINE x1:-.37cm y1:-.06cm x2:-.27cm
ELSIF (search(rp,"(Company map)",0) >= 0)
  FILL color:(color_dodgerblue)
  POLYGON 6 x1:-1cm y1:-.25cm x2:-.2cm y2:-.25cm x3:-.1cm x4:-.2cm y4:.25cm x5:-
1cm y5:.25cm x6:-.9cm
  POLYGON 6 x1:1.35cm y1:-.25cm x2:.65cm y2:-.25cm x3:.75cm x4:.65cm y4:.25cm
x5:1.35cm y5:.25cm x6:1.45cm
  LINE x2:.65cm
  LINE x1:.55cm y1:.06cm x2:.65cm
  LINE x1:.55cm y1:-.06cm x2:.65cm
  LINE y1:-.06cm y2:.06cm
ENDIF
FONT h:(PT grad) color:(col)
IF (rp = "")
  IF (sp = "English")
    ATTR "Name" y:(tabh2 + 0.1cm) w:c:(tabw1 + tabw2 + tabw3) h:t
  ELSE
    ATTR "Bezeichnung" y:(tabh2 + 0.1cm) w:c:(tabw1 + tabw2 + tabw3) h:t
  ENDIF
ELSE
  IF (sp = "English")
    IF (anzeige = "yes")
      ATTR "Name" y:(tabh2 + 0.1cm) w:c:(tabw1 + tabw2 + tabw3) h:t
      ATTRBOX "Name" y:(tabh2 + 0.1cm) w:c:(tabw1 + tabw2 + tabw3) h:t
      FONT "Arial" h:8pt bold
      ATTR "Referenced process" y:(texty2 + .1cm) w:c:(tabw1 + tabw2 + tabw3) h:t
format:"%m"
      FONT h:(PT grad) color:(col)
    
```

```

ELSE
  ATTR "Referenced process" y:(tabh2 + 0.1cm) w:c:(tabw1 + tabw2 + tabw3) h:t
format:"%m"
ENDIF
ELSE
  IF (anzeige = "yes")
    ATTR "Bezeichnung" y:(tabh2 + 0.1cm) w:c:(tabw1 + tabw2 + tabw3) h:t
    ATTRBOX "Bezeichnung" y:(tabh2 + 0.1cm) w:c:(tabw1 + tabw2 + tabw3) h:t
    FONT "Arial" h:8pt bold
    ATTR "Referenced process" text:(sn) y:(texty2 + .1cm) w:c:(tabw1 + tabw2 +
tabw3) h:t line-break:words
    PEN
    FILL
    FONT h:(PT grad) color:(col)
  ELSE
    ATTR "Referenced process" text:(sn) y:(tabh2 + 0.1cm) w:c:(tabw1 + tabw2 +
tabw3) h:t line-break:words
    PEN
    FILL
  ENDIF
ENDIF
ENDIF
IF (i > "0")
  FONT "Arial" h:10.0pt color:white bold
  ATTR "Order" x:(tabx2 - 0.1cm) y:(taby2) w:r:1cm h:b
ENDIF
AVAL of:"Open questions"
IF ( LEN(replall(replall((of)," ",""),"
",""))>0 )
  FONT "Arial" h:10.0pt bold color:(color_red)
  ATTR "Open questions" text:"?" x:(tabx2 - 0.1cm) y:(taby0 - 0.4cm)
ENDIF
FONT "Arial" h:8.0pt
IF ((b_visRefAppl = "1") AND (s_refAppl != ""))
  ATTR "Referenced IT system elements" format:"%o" x:(tabx0) y:(taby0 - 0.02cm)
w:l:(tabw2) h:b:1.5cm line-height:9pt line-break:rigorous
ENDIF

```

1.1.16 Class "Performance indicator overview"

ADONIS BPMS BP Library 3.9:

```

GRAPHREP
SHADOW off
AVAL funkt:"calc_probe_overview_visualization"
AVAL sp:"Language"
IF (sp = "System")
  IF (_uilang = "de")
    SET sp:"German"
  ELSE
    SET sp:"English"
  ENDIF
ENDIF
AVAL score:"probe_overview_score"
AVAL state:"probe_overview_status"
AVAL set-default:"no" mono:"Monochrome view"
IF (mono = "yes")
  SET bMono:1
ELSE

```

Part IV

```
    SET bMono:0
ENDIF
PEN w:0.05cm
IF (bMono)
    FILL color:white
    PEN w:0.05cm
ELSE
FILL color:royalblue
# start - smooth shaded colors
CLIP_POLY 3 x1:.2cm y1:0cm x2:-.3cm y2:.3cm x3:-.3cm y3:-.3cm
GRADIENT_RECT x:-0.7cm y:-.7cm w:1.4cm h:1.4cm style:updiag
    color1:white color2:blue
    PEN w:0.05cm color:royalblue join:miter
    FILL style:null
    CLIP_OFF
# end - smooth shaded colors
ENDIF
POLYGON 3 x1:.2cm y1:0cm x2:-.3cm y2:.3cm x3:-.3cm y3:-.3cm
IF (funkt = "true")
    FONT color:black h:10pt
    ATTRBOX "probe_overview_ref"      x:0.7cm      y:0cm      w:1      h:t
    IF (sp = "English")
        ATTR "probe_overview_ref"      x:(textx1) y:0cm w:(textw) h:c:(texth)
    ELSE
        ATTR "probe_overview_ref_deu"  x:(textx1) y:0cm w:(textw) h:c:(texth)
    ENDIF
    SET y:(texty1)
    ATTRBOX "probe_overview_status" x:(textx2 + 0.3cm) y:(texty2) w:1 h:t
    IF (copy (state,0,12) <> "[acoexpar-04]")
        ATTR "probe_overview_status"  x:(textx1) y:0cm w:(textw) h:c:(texth)
    ELSE
        TEXT "[acoexpar-04] There are broken references in the performance indicator
overview." x:(textx1) y:0cm w:(textw) h:c:(texth)
    ENDIF
    ATTRBOX "probe_overview_score"  x:(textx2 + 0.3cm) y:(texty2) w:1 h:t
    IF (copy (score,0,12) <> "[acoexpar-04]")
        ATTR "probe_overview_score"  x:(textx1) y:0cm w:(textw) h:c:(texth)
    ENDIF
ENDIF
ENDIF
```

1.1.17 Class "Performance indicator"

ADONIS BPMS BP Library 3.9:

```
GRAPHREP
SHADOW off
AVAL grad:"Font size"
AVAL typ:"Font style"
AVAL istwert:"Entry_IST-Wert"
AVAL me:"Unit"
AVAL strState:"Entry_Status"
AVAL score:"Scorevalue"
AVAL sp:"Language"
IF (sp = "System")
    IF (_uilang = "de")
        SET sp:"German"
    ELSE
        SET sp:"English"
    ENDIF
ENDIF
```

```

ENDIF
AVAL k:"Periodicity"
AVAL set-default:("0") vist:"Display current value"
AVAL set-default:("0") vs:"Display periodicity"
AVAL set-default:("0") vscore:"Display score"
AVAL set-default:("0") visstat:"Display status"
AVAL set-default:"no" mono:"Monochrome view"
IF (mono = "yes")
  SET bMono:1
ELSE
  SET bMono:0
ENDIF
PEN w:0.08cm
IF (bMono)
  SET color_dodgerblue:(rgbval("white"))
  SET color_yellow:(rgbval("white"))
  SET color_lime:(rgbval("white"))
  SET color_red:(rgbval("white"))
ELSE
  SET color_dodgerblue:(rgbval("dodgerblue"))
  SET color_yellow:(rgbval("yellow"))
  SET color_lime:(rgbval("lime"))
  SET color_red:(rgbval("red"))
ENDIF
IF (typ = "Standard")
  FONT h:(PT grad)
ELSIF (typ = "Italic")
  FONT h:(PT grad) italic
ELSIF (typ = "Bold")
  FONT h:(PT grad) bold
ELSIF (typ = "Underline")
  FONT h:(PT grad) underline
ELSIF (typ = "Bold Italic")
  FONT h:(PT grad) bold italic
ELSIF (typ = "Bold Underline")
  FONT h:(PT grad) bold underline
ENDIF
IF ( VAL visstat <> 1 )
  SET strState:""
ENDIF
IF (sp = "English")
  ATTR "Name" x:0cm y:t:.9cm w:c:2cm h:t
  ATTRBOX "Name" x:0cm y:t:.9cm w:c:2cm h:t
ELSE
  ATTR "Bezeichnung" x:0cm y:t:.9cm w:c:2cm h:t
  ATTRBOX "Bezeichnung" x:0cm y:t:.9cm w:c:2cm h:t
ENDIF
FILL color:(color_dodgerblue)
PEN w:0.08cm
IF (NOT bMono)
  FILL color:royalblue
  # start - smooth shaded colors
  CLIP_ELLIPSE rx:.7cm ry:.7cm
  GRADIENT_RECT x:-0.7cm y:-.7cm w:1.4cm h:1.4cm style:updiag
    color1:white color2:blue
  PEN w:0.08cm color:royalblue join:miter
  FILL style:null
  CLIP_OFF
  # end - smooth shaded colors
ENDIF
ELLIPSE rx:.7cm ry:.7cm

```

Part IV

```
IF (NOT bMono)
  # start - smooth shaded colors
  CLIP_ELLIPSE rx:.5cm ry:.5cm
  GRADIENT_RECT x:-0.7cm y:-.7cm w:1.4cm h:1.4cm style:updiag
    color1:white color2:$ffffb0
  FILL style:null
  CLIP_OFF
  # end - smooth shaded colors
ENDIF
ELLIPSE rx:.5cm ry:.5cm
IF (NOT bMono)
  # start - smooth shaded colors
  CLIP_ELLIPSE rx:.3cm ry:.3cm
  GRADIENT_RECT x:-0.7cm y:-.7cm w:1.4cm h:1.4cm style:updiag
    color1:yellow color2:red
  PEN w:0.08cm color:$fe5901 join:miter
  FILL style:null
  CLIP_OFF
  # end - smooth shaded colors
ENDIF
ELLIPSE rx:.3cm ry:.3cm
IF (VAL vist = 1)
  FONT h:10pt
  AVAL istwert:"Entry_IST-Wert"
  ATTRBOX "Entry_IST-Wert" text:(istwert) x:(-0.05cm) y:(texty2+0.1cm) w:c h:t
  ATTR "Entry_IST-Wert" text:(istwert) x:(textx1) y:(texty1) w:l h:t
ENDIF
IF (me <> "")
  ATTRBOX "Unit" x:(-.15cm) y:(texty2+0.1cm) w:c h:t
  ATTR "Unit" text:(["+me+"]) x:(textx1) y:(texty1) w:l h:t
ENDIF
IF (VAL vs = 1)
  FONT h:10pt
  IF (k = "Year")
    TEXT "Y"
    x:-0.75cm y:-1.1cm
  ELSIF (k = "Half-year")
    TEXT "HY"
    x:-0.75cm y:-1.1cm
  ELSIF (k = "Quarter")
    TEXT "Q"
    x:-0.75cm y:-1.1cm
  ELSIF (k = "Month")
    TEXT "M"
    x:-0.75cm y:-1.1cm
  ELSIF (k = "Week")
    TEXT "W"
    x:-0.75cm y:-1.1cm
  ELSIF (k = "Day")
    TEXT "D"
    x:-0.75cm y:-1.1cm
  ENDIF
ENDIF
IF (VAL vscore =1)
  FONT h:10pt
  TEXT (score) x:0.55cm y:-1.1cm
ENDIF
IF ( strState <> "" )
  IF ( strState = "Red" )
    FILL color:(color_red)
    PEN color:(color_red)
```



```

ELSIF ( strState = "Green" )
  FILL color:(color_lime)
  PEN color:(color_lime)
ELSIF ( strState = "Yellow" )
  FILL color:(color_yellow)
  PEN color:(color_yellow)
ELSE
  FILL color:lightgray
  PEN color:lightgray
ENDIF
ELLIPSE x:0.85cm y:.55cm rx:0.15cm ry:0.15cm
ENDIF

```

1.1.18 Class "Document"

ADONIS BPMS BP Library 3.9:

```

GRAPHREP
SHADOW off
AVAL set-default:"English" sp:"Language"
IF (sp = "System")
  IF (_uilang = "de")
    SET sp:"German"
  ELSE
    SET sp:"English"
  ENDIF
ENDIF
AVAL set-default:"no" mono:"Monochrome view"
IF (mono = "yes")
  SET bMono:1
ELSE
  SET bMono:0
ENDIF
PEN w:0.05cm
IF (bMono)
  SET color_aqua:(rgbval("white"))
  SET color_848484:(rgbval("$848484"))
  SET color_red:(rgbval("white"))
ELSE
  SET color_aqua:(rgbval("aqua"))
  SET color_848484:(rgbval("$848484"))
  SET color_red:(rgbval("red"))
ENDIF
FILL color:$ffe840
COMPOUND 2
LINE x1:1cm y1:-.5cm x2:-1cm y2:-.5cm
CURVE "t" f:(t) g:(-.2*sin(3.14*(t+2))+1.2) from:-1 to:1
IF (bMono)
  FILL color:white
ELSE
  SHADOW off
  CLIP_RECT x:-1.0cm y:-0.5cm w:2.0cm h:2.0cm
  GRADIENT_RECT x:-1.0cm y:-0.5cm w:2.0cm h:1.47cm style:vert color1:$fff8c6
color2:$ffe840
  CLIP_OFF
  PEN w:0.08cm color:$ffdf00
  FILL style:null
ENDIF
COMPOUND 2

```

Part IV

```
LINE x1:1cm y1:-.5cm x2:-1cm y2:-.5cm
CURVE "t" f:(t) g:(-.2*sin(3.14*(t+2))+1.2) from:-1 to:1
AVAL set-default:"" sRefDocument:"Referenced document"
AVAL col:"fontcolor"
AVAL sName:"Name"
AVAL sNameDE:"Bezeichnung"
SET sFile:(replall(token(sRefDocument, 1, "@"), "\", ""))
IF (sFile != "")
  IF (tokcnt(sFile, ".") > 0)
    SET sExtension:( token(sFile, tokcnt(sFile, ".") - 1, ".") )
    SET sExtension:(lower(sExtension))
  ELSE
    SET sExtension:""
ENDIF
# visualize icons
IF ( (sExtension = "doc") OR (sExtension = "dot") OR (sExtension = "rtf") OR
(sExtension = "txt") OR (sExtension = "pps") OR (sExtension = "ppt") OR (sExtension
= "pdf") )
  # document, preseration or text files
  SET str_bitmap:("db:\\icon_document.png")
  ELSIF ( (sExtension = "xls") OR (sExtension = "csv") OR (sExtension = "xla") OR
(sExtension = "xlt") OR (sExtension = "xl") OR (sExtension = "xlm") )
  # files with tabular content
  SET str_bitmap:("db:\\icon_table.png")
  ELSIF ( (sExtension = "htm") OR (sExtension = "html") )
  # web files
  SET str_bitmap:("db:\\icon_web.png")
  ELSIF ( (sExtension = "png") OR (sExtension = "bmp") OR (sExtension = "gif") OR
(sExtension = "jpeg") OR (sExtension = "jpg") OR (sExtension = "svg") OR (sExten-
sion = "emf") OR (sExtension = "pcx") )
  # graphic file type
  SET str_bitmap:("db:\\icon_gfx.png")
  ELSE
  # unknown file type
  SET str_bitmap:("db:\\icon_unknown.png")
ENDIF
SET cms_width:1.00cm
SET cms_height:1.35cm
BITMAPINFO (str_bitmap) # get the bitmap size
STRETCH off
IF (bmpwidth / CMS cms_width < bmpheight / CMS cms_height)
  # use maximum height, space left and right
  SET w:(cms_height * (bmpwidth / bmpheight))
  BITMAP (str_bitmap) x:((0cm - w) / 2) y:((0.5cm - cms_height) / 2) w:(w)
h:(cms_height)
ELSE
  # use maximum width, space at top and bottom
  SET h:(cms_width * (bmpheight / bmpwidth))
  BITMAP (str_bitmap) x:((0.0cm - cms_width) / 2) y:((0.5cm - h) / 2)
w:(cms_width) h:(h)
ENDIF
FONT bold
TEXT (sExtension) x:1cm y:-0.95cm w:r:2.0cm h:0.5cm line-break:rigorous
FONT
AVAL set-default:"0" bShowFilename:"Display file extension"
IF (bShowFilename = "1")
  SET nPos:(bsearch(sFile, "\\", -1))
  IF (nPos > 0)
    SET sBasename:(copy(sFile, nPos + 1, -1))
  ELSE
    SET sBasename:(sFile)
```

```

ENDIF
ATTR "Referenced document" text:(sBasename) y:1.6cm w:c:2.8cm h:t
ELSE
IF (sp = "English")
ATTR "Referenced document" text:(sName) y:1.6cm w:c:2.8cm h:t
ELSE
ATTR "Referenced document" text:(sNameEN) y:1.6cm w:c:2.8cm h:t
ENDIF
ENDIF
ELSE
FONT color:(col)
IF (sp = "English")
ATTR "Name" y:1.6cm w:c:2.8cm h:t
ELSE
ATTR "Bezeichnung" y:1.6cm w:c:2.8cm h:t
ENDIF
ENDIF
ENDIF

```

1.1.19 Class "Note"

ADONIS BPMS BP Library 3.9:

```

GRAPHREP layer:0 sizing:asymmetrical
SHADOW off
AVAL set-default:"" a:"External graphic"
AVAL sp:"Language"
IF (sp = "System")
IF (_uilang = "de")
SET sp:"German"
ELSE
SET sp:"English"
ENDIF
ENDIF
AVAL set-default:"No" autoB:"Calculate size of graphic automatically"
AVAL set-default:"lemonchiffon" f:"Color"
AVAL set-default:"no" mono:"Monochrome view"
IF (mono = "yes")
SET bMono:1
ELSE
SET bMono:0
ENDIF
IF (bMono)
SET f:"white"
ENDIF
SET found:(search(a,"\\",0))
IF (found >= 0)
IF (found = (LEN a - 1))
SET s:(search(a,"@",0) + 1)
SET e:((LEN a) - 1)
ELSE
SET s:((found) + 1)
SET foundend:(search(a,"\\",s))
IF (foundend >= 0)
SET e:((LEN a) - 1)
ELSE
SET e:(LEN a)
ENDIF
ENDIF
ELSE

```

Part IV

```
SET e:(LEN a)
SET s:(search(a,"@",0) + 1)
ENDIF
SET grfk:(copy (a, s, e - s))
SET s:((LEN grfk) - 4)
SET e:((LEN grfk))
SET ext:(copy (grfk, s, e))
# -- build obj --
SET ext:(lower(ext))
# ---
TABLE w:4.5cm h:4.5cm cols:3 rows:3
w1:.15cm w2:100% w3:.15cm
h1:.15cm h2:100% h3:.15cm
STRETCH off
IF (autoB = "No")
  IF ( (ext=".bmp") OR (ext=".gif") OR (ext=".ico") OR (ext=".jpg") OR
(ext=".jpeg") OR (ext=".png") OR (ext=".targa") OR (ext=".tiff") OR (ext=".wbmp")
OR (ext=".xpm") )
    BITMAP (grfk) w:(tabw1 + tabw2 + tabw3) h:(tabh1 + tabh2 + tabh3)
  ELSE
    PEN color:darkgray outline
    FILL color:(rgbval (f))
    RECTANGLE w:(tabw1 + tabw2 + tabw3) h:(tabh1 + tabh2 + tabh3)
    AVAL grad:"Font size"
    AVAL typ:"Font style"
    IF (typ = "Standard")
      FONT h:(PT grad)
    ELSIF (typ = "Italic")
      FONT h:(PT grad) italic
    ELSIF (typ = "Bold")
      FONT h:(PT grad) bold
    ELSIF (typ = "Underline")
      FONT h:(PT grad) underline
    ELSIF (typ = "Bold Italic")
      FONT h:(PT grad) bold italic
    ELSIF (typ = "Bold Underline")
      FONT h:(PT grad) bold underline
    ENDIF
    IF (sp="English")
      ATTR "Text" x:(tabx1) y:(taby1) w:(tabw2) h:(tabh2)
    ELSE
      ATTR "Notiz" x:(tabx1) y:(taby1) w:(tabw2) h:(tabh2)
    ENDIF
  ENDIF
ENDIF
# ---
ELSIF (autoB = "Yes")
  IF ( (ext=".bmp") OR (ext=".gif") OR (ext=".ico") OR (ext=".jpg") OR
(ext=".jpeg") OR (ext=".png") OR (ext=".targa") OR (ext=".tiff") OR (ext=".wbmp")
OR (ext=".xpm") )
    BITMAPINFO (grfk) # get the bitmap size
    STRETCH off
    IF (bmpwidth > bmpheight)
# use maximum height, space left and right
      SET w:(tabw1 + tabw2 + tabw3)
      SET h:(((tabw1 + tabw2 + tabw3) * bmpheight) / bmpwidth)
      BITMAP (grfk) x:0cm y:0cm w:(w) h:(h)
      #BITMAP (grfk) x:0cm y:0cm w:(CM bmpwidth) h:(CM bmpheight)
    ELSE
# use maximum width, space at top and bottom
      SET w:(((tabh1 + tabh2 + tabh3) * bmpwidth) / bmpheight)
      SET h:(tabh1 + tabh2 + tabh3)
```

```

        BITMAP (grfk) x:0cm y:0cm w:(w) h:(h)
    ENDIF
ELSE
    PEN color:darkgray outline
    FILL color:(rgbval (f))
    RECTANGLE w:(tabw1 + tabw2 + tabw3) h:(tabh1 + tabh2 + tabh3)
    AVAL grad:"Font size"
    AVAL typ:"Font style"
    IF (typ = "Standard")
        FONT h:(PT grad)
    ELSIF (typ = "Italic")
        FONT h:(PT grad) italic
    ELSIF (typ = "Bold")
        FONT h:(PT grad) bold
    ELSIF (typ = "Underline")
        FONT h:(PT grad) underline
    ELSIF (typ = "Bold Italic")
        FONT h:(PT grad) bold italic
    ELSIF (typ = "Bold Underline")
        FONT h:(PT grad) bold underline
    ENDIF
    IF (sp="English")
        ATTR "Text" x:(tabx1) y:(taby1) w:(tabw2) h:(tabh2)
    ELSE
        ATTR "Notiz" x:(tabx1) y:(taby1) w:(tabw2) h:(tabh2)
    ENDIF
ENDIF
ENDIF

```

1.1.20 Class "Aggregation"

ADONIS BPMS BP Library 3.9:

```

GRAPHREP layer:-1 sizing:asymmetrical
SHADOW off
AVAL sp:"Language"
IF (sp = "System")
    IF (_uilang = "de")
        SET sp:"German"
    ELSE
        SET sp:"English"
    ENDIF
ENDIF
AVAL set-default:"lightgray" f:"Color"
AVAL s:"Lines"
AVAL sForm:"Graphical representation"
AVAL set-default:"no" mono:"Monochrome view"
IF (mono = "yes")
    SET bMono:1
ELSE
    SET bMono:0
ENDIF
PEN w:0.05cm
IF (bMono)
    SET color_x:(rgbval("white"))
ELSE
    SET color_x:(rgbval(f))
ENDIF
IF (s = "Dots")

```

Part IV

```
PEN style:dot
ELSIF (s = "Lines")
  PEN style:dash
ELSIF (s = "Dots/Lines")
  PEN style:dashdot
ELSIF (s = "Bold")
  PEN w:0.05cm
ELSIF (s = "None")
  PEN style:null
ENDIF
FILL color:(color_x)
IF (sForm = "Circle")
  # circle
  ELLIPSE x:3.0cm y:3.0cm rx:3.0cm ry:3.0cm
  TABLE x:0.0cm y:0.0cm w:6.0cm h:6.0cm
    rows:3 cols:3
    w1:0.15cm w2:100% w3:.15cm
    h1:.1cm h2:100% h3:.1cm
ELSIF (sForm = "Right arrow")
  # circle
  TABLE x:0.0cm y:0.0cm w:6.0cm h:9.0cm
    rows:3 cols:3
    w1:0.15cm w2:100% w3:.5cm
    h1:.1cm h2:100% h3:.1cm
  STRETCH off
  POLYGON 5 x1:(tabx0) y1:(taby0) x2:(tabx2) y2:(taby0) x3:(tabx3)
x3:(tabx3) y3:((tabh1+tabh2+tabh3)/2) x4:(tabx2) y4:(tabh1+tabh2+tabh3) x5:(tabx0)
y5:(tabh1+tabh2+tabh3)
ELSIF (sForm = "Left arrow")
  # circle
  TABLE x:0.0cm y:0.0cm w:6.0cm h:9.0cm
    rows:3 cols:3
    w1:0.5cm w2:100% w3:.15cm
    h1:.1cm h2:100% h3:.1cm
  STRETCH off
  POLYGON 5 x1:(tabx1) y1:(taby0) x2:(tabx3) y2:(taby0) x3:(tabx3) y3:(taby3)
x4:(tabx1) y4:(taby3) x5:(tabx0) y5:((tabh1+tabh2+tabh3)/2)
ELSIF (sForm = "Downward arrow")
  # circle
  TABLE x:0.0cm y:0.0cm w:6.0cm h:9.0cm
    rows:3 cols:3
    w1:.15cm w2:100% w3:.15cm
    h1:.1cm h2:100% h3:1.0cm
  STRETCH off
  POLYGON 5 x1:(tabx0) y1:(taby0) x2:(tabx3) y2:(taby0) x3:(tabx3) y3:(taby2)
x4:((tabw1+tabw2+tabw3)/2) y4:(taby3) x5:(tabx0) y5:(taby2)
ELSIF (sForm = "Upward arrow")
  # circle
  TABLE x:0.0cm y:0.0cm w:6.0cm h:9.0cm
    rows:3 cols:3
    w1:.15cm w2:100% w3:.15cm
    h1:1.0cm h2:100% h3:.1cm
  STRETCH off
  POLYGON 5 x1:(tabx0) y1:(taby1) x2:((tabw1+tabw2+tabw3)/2) y2:(taby0) x3:(tabx3)
y3:(taby1) x4:(tabx3) y4:(taby3) x5:(tabx0) y5:(taby3)
ELSE
  # standard form
  RECTANGLE x:0.0cm y:0.0cm w:6.0cm h:9.0cm
  TABLE x:0.0cm y:0.0cm w:6.0cm h:9.0cm
    rows:3 cols:3
    w1:0.15cm w2:100% w3:.15cm
```

```

        h1:.1cm h2:100% h3:.1cm
ENDIF
STRETCH off
FONT h:10pt
AVAL d:"Representation"
AVAL n:"Display name"
AVAL sName:"Name"
AVAL sNameEng:"Bezeichnung"
IF (d = "inside")
    AVAL col:"Fontcolor"
ELSE
    AVAL col:"fontcolor"
ENDIF
IF (n = "Yes")
    AVAL grad:"Font size"
    AVAL typ:"Font style"
    IF (typ = "Standard")
        FONT h:(PT grad)
    ELSIF (typ = "Italic")
        FONT h:(PT grad) italic
    ELSIF (typ = "Bold")
        FONT h:(PT grad) bold
    ELSIF (typ = "Underline")
        FONT h:(PT grad) underline
    ELSIF (typ = "Bold Italic")
        FONT h:(PT grad) bold italic
    ELSIF (typ = "Bold Underline")
        FONT h:(PT grad) bold underline
    ENDIF
    AVAL sName:"Name"
    AVAL sNameGer:"Bezeichnung"
    SET sVis:"asdf"
    IF (sp = "English")
        SET sVis:(sName)
    ELSE
        SET sVis:(sNameGer)
    ENDIF
    IF (sForm = "Circle")
        IF (d = "inside")
            ATTR "Name" text:(sVis) x:((tabw1+tabw2+tabw3)/2) y:((tabh1+tabh2+tabh3)/2)
w:c:(tabw2) h:c
        ELSE
            ATTR "Name" text:(sVis) x:((tabw1+tabw2+tabw3)/2) y:(taby0) w:c:(tabw2) h:b
        ENDIF
    ELSIF (sForm = "upward arrow")
        IF (d = "inside")
            ATTR "Name" text:(sVis) x:((tabw1+tabw2+tabw3)/2) y:(taby1 - 0.4cm)
w:c:(tabw2) h:t
        ELSE
            ATTR "Name" text:(sVis) x:((tabw1+tabw2+tabw3)/2) y:(taby0) w:c:(tabw2) h:b
        ENDIF
    ELSE
        IF (d = "inside")
            ATTR "Name" text:(sVis) x:(tabx1) y:(taby1) w:(tabw2) h:(tabh2)
        ELSE
            ATTR "Name" text:(sVis) x:(tabx1) y:-.05cm w:(tabw2) h:b
        ENDIF
    ENDIF
ENDIF
ENDIF

```

1.1.21 Class "Swimlane (horizontal)"

ADONIS BPMS BP Library 3.9:

```

GRAPHREP swimlane:horizontal layer:-3
SHADOW off
AVAL sName_de:"Name"
AVAL sName_en:"Bezeichnung"
AVAL o:"Working environment"
AVAL refIT:"Referenced IT system elements"
PEN style:null
AVAL set-default:"$ffffff" c:"Color"
AVAL cl:"Fontcolor"
AVAL or:"Alignment"
AVAL w:"Display water marks"
AVAL sp:"Language"
IF (sp = "System")
  IF (_uilang = "de")
    SET sp:"German"
  ELSE
    SET sp:"English"
  ENDIF
ENDIF
FILL color:(rgbval (c))
PEN color:black
RECTANGLE w:6cm h:4cm
TABLE rows:3 cols:2 w:6cm h:4cm w1:4cm w2:100% h1:0.1cm h2:100% h3:0.1cm
STRETCH off
IF (sp = "English")
  AVAL set-format:"%o" sInterrefText:"Working environment"
  AVAL set-format:"%o" sInterrefText_2:"Referenced IT system elements"
ELSE
  AVAL as-original-type sInterrefText:"refObjectNameDE"
  AVAL as-original-type sInterrefText_2:"refObjectNameDE_2"
  #SET sInterrefText:"ELSE-Zweig"
ENDIF
FONT color:(cl) h:14pt bold
IF (token(sInterrefText, 0, "-") = "[aleo]")
  SET sInterrefText:(cond(sp="English", sName_en, sName_de))
ENDIF
IF (token(sInterrefText_2, 0, "-") = "[aleo]")
  SET sInterrefText_2:(cond(sp="English", sName_en, sName_de))
ENDIF
IF (o != "")
  IF (or = "center")
    ATTR "Working environment" text:(sInterrefText) x:(tabx0 + (tabw1 / 2))
y:(taby1 + (tabh2 / 2)) w:c:(tabw1) h:c:(tabh2) line-break:rigorous
  ELSIF (or = "top")
    ATTR "Working environment" text:(sInterrefText) x:(tabx0 + (tabw1 / 2))
y:(taby1) w:c:(tabw1) h:t:(tabh2) line-break:rigorous
  ELSE
    ATTR "Working environment" text:(sInterrefText) x:(tabx0 + (tabw1 / 2))
y:(taby2) w:c:(tabw1) h:b:(tabh2) line-break:rigorous
  ENDIF
  IF (w="yes")
    IF ((tabw1 + tabw2) > 30cm)
      SET cl:$b5b5b5
      FONT color:(cl) h:14pt bold
      IF (or = "center")
        ATTR "Working environment" text:(sInterrefText) format:"%o" x:19.0cm
y:(taby1 + (tabh2 / 2)) w:c:(tabw1) h:c:(tabh2) line-break:rigorous
      
```



```

        ELSIF (or = "top")
            ATTR "Working environment" text:(sInterrefText) format:"%o" x:19.0cm
y:(taby1) w:c:(tabw1) h:t:(tabh2) line-break:rigorous
        ELSE
            ATTR "Working environment" text:(sInterrefText) format:"%o" x:19.0cm
y:(taby2) w:c:(tabw1) h:b:(tabh2) line-break:rigorous
        ENDIF
    ENDIF
    IF ((tabw1 + tabw2) > 50cm)
        IF (or = "center")
            ATTR "Working environment" text:(sInterrefText) format:"%o" x:38.0cm
y:(taby1 + (tabh2 / 2)) w:c:(tabw1) h:c:(tabh2) line-break:rigorous
            ELSIF (or = "top")
                ATTR "Working environment" text:(sInterrefText) format:"%o" x:38.0cm
y:(taby1) w:c:(tabw1) h:t:(tabh2) line-break:rigorous
            ELSE
                ATTR "Working environment" text:(sInterrefText) format:"%o" x:38.0cm
y:(taby2) w:c:(tabw1) h:b:(tabh2) line-break:rigorous
            ENDIF
        ENDIF
        IF ((tabw1 + tabw2) > 70cm)
            IF (or = "center")
                ATTR "Working environment" text:(sInterrefText) format:"%o" x:57.0cm
y:(taby1 + (tabh2 / 2)) w:c:(tabw1) h:c:(tabh2) line-break:rigorous
            ELSIF (or = "top")
                ATTR "Working environment" text:(sInterrefText) format:"%o" x:57.0cm
y:(taby1) w:c:(tabw1) h:t:(tabh2) line-break:rigorous
            ELSE
                ATTR "Working environment" text:(sInterrefText) format:"%o" x:57.0cm
y:(taby2) w:c:(tabw1) h:b:(tabh2) line-break:rigorous
            ENDIF
        ENDIF
        IF ((tabw1 + tabw2) > 90cm)
            IF (or = "center")
                ATTR "Working environment" text:(sInterrefText) format:"%o" x:76.0cm
y:(taby1 + (tabh2 / 2)) w:c:(tabw1) h:c:(tabh2) line-break:rigorous
            ELSIF (or = "top")
                ATTR "Working environment" text:(sInterrefText) format:"%o" x:76.0cm
y:(taby1) w:c:(tabw1) h:t:(tabh2) line-break:rigorous
            ELSE
                ATTR "Working environment" text:(sInterrefText) format:"%o" x:76.0cm
y:(taby2) w:c:(tabw1) h:b:(tabh2) line-break:rigorous
            ENDIF
        ENDIF
        IF ((tabw1 + tabw2) > 110cm)
            IF (or = "center")
                ATTR "Working environment" text:(sInterrefText) format:"%o" x:95.0cm
y:(taby1 + (tabh2 / 2)) w:c:(tabw1) h:c:(tabh2) line-break:rigorous
            ELSIF (or = "top")
                ATTR "Working environment" text:(sInterrefText) format:"%o" x:95.0cm
y:(taby1) w:c:(tabw1) h:t:(tabh2) line-break:rigorous
            ELSE
                ATTR "Working environment" text:(sInterrefText) format:"%o" x:95.0cm
y:(taby2) w:c:(tabw1) h:b:(tabh2) line-break:rigorous
            ENDIF
        ENDIF
        IF ((tabw1 + tabw2) > 130cm)
            IF (or = "center")
                ATTR "Working environment" text:(sInterrefText) format:"%o" x:114.0cm
y:(taby1 + (tabh2 / 2)) w:c:(tabw1) h:c:(tabh2) line-break:rigorous
            ELSIF (or = "top")

```

Part IV

```
ATTR "Working environment" text:(sInterrefText) format:"%o" x:114.0cm
y:(taby1) w:c:(tabw1) h:t:(tabh2) line-break:rigorous
ELSE
ATTR "Working environment" text:(sInterrefText) format:"%o" x:114.0cm
y:(taby2) w:c:(tabw1) h:b:(tabh2) line-break:rigorous
ENDIF
ENDIF
IF ((tabw1 + tabw2) > 150cm)
IF (or = "center")
ATTR "Working environment" text:(sInterrefText) format:"%o" x:133.0cm
y:(taby1 + (tabh2 / 2)) w:c:(tabw1) h:c:(tabh2) line-break:rigorous
ELSIF (or = "top")
ATTR "Working environment" text:(sInterrefText) format:"%o" x:133.0cm
y:(taby1) w:c:(tabw1) h:t:(tabh2) line-break:rigorous
ELSE
ATTR "Working environment" text:(sInterrefText) format:"%o" x:133.0cm
y:(taby2) w:c:(tabw1) h:b:(tabh2) line-break:rigorous
ENDIF
ENDIF
IF ((tabw1 + tabw2) > 170cm)
IF (or = "center")
ATTR "Working environment" text:(sInterrefText) format:"%o" x:152.0cm
y:(taby1 + (tabh2 / 2)) w:c:(tabw1) h:c:(tabh2) line-break:rigorous
ELSIF (or = "top")
ATTR "Working environment" text:(sInterrefText) format:"%o" x:152.0cm
y:(taby1) w:c:(tabw1) h:t:(tabh2) line-break:rigorous
ELSE
ATTR "Working environment" text:(sInterrefText) format:"%o" x:152.0cm
y:(taby2) w:c:(tabw1) h:b:(tabh2) line-break:rigorous
ENDIF
ENDIF
IF ((tabw1 + tabw2) > 190cm)
IF (or = "center")
ATTR "Working environment" text:(sInterrefText) format:"%o" x:171.0cm
y:(taby1 + (tabh2 / 2)) w:c:(tabw1) h:c:(tabh2) line-break:rigorous
ELSIF (or = "top")
ATTR "Working environment" text:(sInterrefText) format:"%o" x:171.0cm
y:(taby1) w:c:(tabw1) h:t:(tabh2) line-break:rigorous
ELSE
ATTR "Working environment" text:(sInterrefText) format:"%o" x:171.0cm
y:(taby2) w:c:(tabw1) h:b:(tabh2) line-break:rigorous
ENDIF
ENDIF
IF ((tabw1 + tabw2) > 210cm)
IF (or = "center")
ATTR "Working environment" text:(sInterrefText) format:"%o" x:190.0cm
y:(taby1 + (tabh2 / 2)) w:c:(tabw1) h:c:(tabh2) line-break:rigorous
ELSIF (or = "top")
ATTR "Working environment" text:(sInterrefText) format:"%o" x:190.0cm
y:(taby1) w:c:(tabw1) h:t:(tabh2) line-break:rigorous
ELSE
ATTR "Working environment" text:(sInterrefText) format:"%o" x:190.0cm
y:(taby2) w:c:(tabw1) h:b:(tabh2) line-break:rigorous
ENDIF
ENDIF
IF ((tabw1 + tabw2) > 230cm)
IF (or = "center")
ATTR "Working environment" text:(sInterrefText) format:"%o" x:209.0cm
y:(taby1 + (tabh2 / 2)) w:c:(tabw1) h:c:(tabh2) line-break:rigorous
ELSIF (or = "top")
```

```

        ATTR "Working environment" text:(sInterrefText) format:"%o" x:209.0cm
y:(taby1) w:c:(tabw1) h:t:(tabh2) line-break:rigorous
    ELSE
        ATTR "Working environment" text:(sInterrefText) format:"%o" x:209.0cm
y:(taby2) w:c:(tabw1) h:b:(tabh2) line-break:rigorous
    ENDIF
ENDIF
ENDIF
ELSIF (refIT != "")
    IF (or = "center")
        ATTR "Referenced IT system elements" text:(sInterrefText_2) x:(tabx0 + (tabw1 /
2)) y:(taby1 + (tabh2 / 2)) w:c:(tabw1) h:c:(tabh2) line-break:rigorous
        ELSIF (or = "top")
            ATTR "Referenced IT system elements" text:(sInterrefText_2) x:(tabx0 + (tabw1 /
2)) y:(taby1) w:c:(tabw1) h:t:(tabh2) line-break:rigorous
        ELSE
            ATTR "Referenced IT system elements" text:(sInterrefText_2) x:(tabx0 + (tabw1 /
2)) y:(taby2) w:c:(tabw1) h:b:(tabh2) line-break:rigorous
        ENDIF
        IF (w="yes")
            IF ((tabw1 + tabw2) > 30cm)
                SET c1:$b5b5b5
                FONT color:(c1) h:14pt bold
                IF (or = "center")
                    ATTR "Referenced IT system elements" text:(sInterrefText_2) format:"%o"
x:19.0cm y:(taby1 + (tabh2 / 2)) w:c:(tabw1) h:c:(tabh2) line-break:rigorous
                ELSIF (or = "top")
                    ATTR "Referenced IT system elements" text:(sInterrefText_2) format:"%o"
x:19.0cm y:(taby1) w:c:(tabw1) h:t:(tabh2) line-break:rigorous
                ELSE
                    ATTR "Referenced IT system elements" text:(sInterrefText_2) format:"%o"
x:19.0cm y:(taby2) w:c:(tabw1) h:b:(tabh2) line-break:rigorous
                ENDIF
            ENDIF
            IF ((tabw1 + tabw2) > 50cm)
                IF (or = "center")
                    ATTR "Referenced IT system elements" text:(sInterrefText_2) format:"%o"
x:38.0cm y:(taby1 + (tabh2 / 2)) w:c:(tabw1) h:c:(tabh2) line-break:rigorous
                ELSIF (or = "top")
                    ATTR "Referenced IT system elements" text:(sInterrefText_2) format:"%o"
x:38.0cm y:(taby1) w:c:(tabw1) h:t:(tabh2) line-break:rigorous
                ELSE
                    ATTR "Referenced IT system elements" text:(sInterrefText_2) format:"%o"
x:38.0cm y:(taby2) w:c:(tabw1) h:b:(tabh2) line-break:rigorous
                ENDIF
            ENDIF
            IF ((tabw1 + tabw2) > 70cm)
                IF (or = "center")
                    ATTR "Referenced IT system elements" text:(sInterrefText_2) format:"%o"
x:57.0cm y:(taby1 + (tabh2 / 2)) w:c:(tabw1) h:c:(tabh2) line-break:rigorous
                ELSIF (or = "top")
                    ATTR "Referenced IT system elements" text:(sInterrefText_2) format:"%o"
x:57.0cm y:(taby1) w:c:(tabw1) h:t:(tabh2) line-break:rigorous
                ELSE
                    ATTR "Referenced IT system elements" text:(sInterrefText_2) format:"%o"
x:57.0cm y:(taby2) w:c:(tabw1) h:b:(tabh2) line-break:rigorous
                ENDIF
            ENDIF
            IF ((tabw1 + tabw2) > 90cm)
                IF (or = "center")

```

Part IV

```
ATTR "Referenced IT system elements" text:(sInterrefText_2) format:"%o"
x:76.0cm y:(taby1 + (tabh2 / 2)) w:c:(tabw1) h:c:(tabh2) line-break:rigorous
ELSIF (or = "top")
ATTR "Referenced IT system elements" text:(sInterrefText_2) format:"%o"
x:76.0cm y:(taby1) w:c:(tabw1) h:t:(tabh2) line-break:rigorous
ELSE
ATTR "Referenced IT system elements" text:(sInterrefText_2) format:"%o"
x:76.0cm y:(taby2) w:c:(tabw1) h:b:(tabh2) line-break:rigorous
ENDIF
ENDIF
IF ((tabw1 + tabw2) > 110cm)
IF (or = "center")
ATTR "Referenced IT system elements" text:(sInterrefText_2) format:"%o"
x:95.0cm y:(taby1 + (tabh2 / 2)) w:c:(tabw1) h:c:(tabh2) line-break:rigorous
ELSIF (or = "top")
ATTR "Referenced IT system elements" text:(sInterrefText_2) format:"%o"
x:95.0cm y:(taby1) w:c:(tabw1) h:t:(tabh2) line-break:rigorous
ELSE
ATTR "Referenced IT system elements" text:(sInterrefText_2) format:"%o"
x:95.0cm y:(taby2) w:c:(tabw1) h:b:(tabh2) line-break:rigorous
ENDIF
ENDIF
IF ((tabw1 + tabw2) > 130cm)
IF (or = "center")
ATTR "Referenced IT system elements" text:(sInterrefText_2) format:"%o"
x:114.0cm y:(taby1 + (tabh2 / 2)) w:c:(tabw1) h:c:(tabh2) line-break:rigorous
ELSIF (or = "top")
ATTR "Referenced IT system elements" text:(sInterrefText_2) format:"%o"
x:114.0cm y:(taby1) w:c:(tabw1) h:t:(tabh2) line-break:rigorous
ELSE
ATTR "Referenced IT system elements" text:(sInterrefText_2) format:"%o"
x:114.0cm y:(taby2) w:c:(tabw1) h:b:(tabh2) line-break:rigorous
ENDIF
ENDIF
IF ((tabw1 + tabw2) > 150cm)
IF (or = "center")
ATTR "Referenced IT system elements" text:(sInterrefText_2) format:"%o"
x:133.0cm y:(taby1 + (tabh2 / 2)) w:c:(tabw1) h:c:(tabh2) line-break:rigorous
ELSIF (or = "top")
ATTR "Referenced IT system elements" text:(sInterrefText_2) format:"%o"
x:133.0cm y:(taby1) w:c:(tabw1) h:t:(tabh2) line-break:rigorous
ELSE
ATTR "Referenced IT system elements" text:(sInterrefText_2) format:"%o"
x:133.0cm y:(taby2) w:c:(tabw1) h:b:(tabh2) line-break:rigorous
ENDIF
ENDIF
IF ((tabw1 + tabw2) > 170cm)
IF (or = "center")
ATTR "Referenced IT system elements" text:(sInterrefText_2) format:"%o"
x:152.0cm y:(taby1 + (tabh2 / 2)) w:c:(tabw1) h:c:(tabh2) line-break:rigorous
ELSIF (or = "top")
ATTR "Referenced IT system elements" text:(sInterrefText_2) format:"%o"
x:152.0cm y:(taby1) w:c:(tabw1) h:t:(tabh2) line-break:rigorous
ELSE
ATTR "Referenced IT system elements" text:(sInterrefText_2) format:"%o"
x:152.0cm y:(taby2) w:c:(tabw1) h:b:(tabh2) line-break:rigorous
ENDIF
ENDIF
IF ((tabw1 + tabw2) > 190cm)
IF (or = "center")
```

```

        ATTR "Referenced IT system elements" text:(sInterrefText_2) format:"%"
x:171.0cm y:(taby1 + (tabh2 / 2)) w:c:(tabw1) h:c:(tabh2) line-break:rigorous
        ELSIF (or = "top")
        ATTR "Referenced IT system elements" text:(sInterrefText_2) format:"%"
x:171.0cm y:(taby1) w:c:(tabw1) h:t:(tabh2) line-break:rigorous
        ELSE
        ATTR "Referenced IT system elements" text:(sInterrefText_2) format:"%"
x:171.0cm y:(taby2) w:c:(tabw1) h:b:(tabh2) line-break:rigorous
        ENDIF
    ENDIF
    IF ((tabw1 + tabw2) > 210cm)
        IF (or = "center")
        ATTR "Referenced IT system elements" text:(sInterrefText_2) format:"%"
x:190.0cm y:(taby1 + (tabh2 / 2)) w:c:(tabw1) h:c:(tabh2) line-break:rigorous
        ELSIF (or = "top")
        ATTR "Referenced IT system elements" text:(sInterrefText_2) format:"%"
x:190.0cm y:(taby1) w:c:(tabw1) h:t:(tabh2) line-break:rigorous
        ELSE
        ATTR "Referenced IT system elements" text:(sInterrefText_2) format:"%"
x:190.0cm y:(taby2) w:c:(tabw1) h:b:(tabh2) line-break:rigorous
        ENDIF
    ENDIF
    IF ((tabw1 + tabw2) > 230cm)
        IF (or = "center")
        ATTR "Referenced IT system elements" text:(sInterrefText_2) format:"%"
x:209.0cm y:(taby1 + (tabh2 / 2)) w:c:(tabw1) h:c:(tabh2) line-break:rigorous
        ELSIF (or = "top")
        ATTR "Referenced IT system elements" text:(sInterrefText_2) format:"%"
x:209.0cm y:(taby1) w:c:(tabw1) h:t:(tabh2) line-break:rigorous
        ELSE
        ATTR "Referenced IT system elements" text:(sInterrefText_2) format:"%"
x:209.0cm y:(taby2) w:c:(tabw1) h:b:(tabh2) line-break:rigorous
        ENDIF
    ENDIF
    ENDIF
    ELSE
    IF (sp = "English")
    IF (or = "center")
    ATTR "Name" x:(tabx0 + (tabw1 / 2)) y:(taby1 + (tabh2 / 2)) w:c:(tabw1)
h:c:(tabh2) line-break:rigorous
    ELSIF (or = "top")
    ATTR "Name" x:(tabx0 + (tabw1 / 2)) y:(taby1) w:c:(tabw1) h:t:(tabh2) line-
break:rigorous
    ELSE
    ATTR "Name" x:(tabx0 + (tabw1 / 2)) y:(taby2) w:c:(tabw1) h:b:(tabh2) line-
break:rigorous
    ENDIF
    IF (w="yes")
    IF ((tabw1 + tabw2) > 30cm)
    SET cl:$b5b5b5
    FONT color:(cl) h:14pt bold
    IF (or = "center")
    ATTR "Name" x:19.0cm y:(taby1 + (tabh2 / 2)) w:c:(tabw1) h:c:(tabh2)
line-break:rigorous
    ELSIF (or = "top")
    ATTR "Name" x:19.0cm y:(taby1) w:c:(tabw1) h:t:(tabh2) line-
break:rigorous
    ELSE
    ATTR "Name" x:19.0cm y:(taby2) w:c:(tabw1) h:b:(tabh2) line-
break:rigorous
    ENDIF
    ENDIF
    ENDIF

```

Part IV

```
ENDIF
IF ((tabw1 + tabw2) > 50cm)
  IF (or = "center")
    ATTR "Name" x:38.0cm y:(taby1 + (tabh2 / 2)) w:c:(tabw1) h:c:(tabh2)
line-break:rigorous
  ELSIF (or = "top")
    ATTR "Name" x:38.0cm y:(taby1) w:c:(tabw1) h:t:(tabh2) line-
break:rigorous
  ELSE
    ATTR "Name" x:38.0cm y:(taby2) w:c:(tabw1) h:b:(tabh2) line-
break:rigorous
  ENDIF
ENDIF
IF ((tabw1 + tabw2) > 70cm)
  IF (or = "center")
    ATTR "Name" x:57.0cm y:(taby1 + (tabh2 / 2)) w:c:(tabw1) h:c:(tabh2)
line-break:rigorous
  ELSIF (or = "top")
    ATTR "Name" x:57.0cm y:(taby1) w:c:(tabw1) h:t:(tabh2) line-
break:rigorous
  ELSE
    ATTR "Name" x:57.0cm y:(taby2) w:c:(tabw1) h:b:(tabh2) line-
break:rigorous
  ENDIF
ENDIF
IF ((tabw1 + tabw2) > 90cm)
  IF (or = "center")
    ATTR "Name" x:76.0cm y:(taby1 + (tabh2 / 2)) w:c:(tabw1) h:c:(tabh2)
line-break:rigorous
  ELSIF (or = "top")
    ATTR "Name" x:76.0cm y:(taby1) w:c:(tabw1) h:t:(tabh2) line-
break:rigorous
  ELSE
    ATTR "Name" x:76.0cm y:(taby2) w:c:(tabw1) h:b:(tabh2) line-
break:rigorous
  ENDIF
ENDIF
IF ((tabw1 + tabw2) > 110cm)
  IF (or = "center")
    ATTR "Name" x:95.0cm y:(taby1 + (tabh2 / 2)) w:c:(tabw1) h:c:(tabh2)
line-break:rigorous
  ELSIF (or = "top")
    ATTR "Name" x:95.0cm y:(taby1) w:c:(tabw1) h:t:(tabh2) line-
break:rigorous
  ELSE
    ATTR "Name" x:95.0cm y:(taby2) w:c:(tabw1) h:b:(tabh2) line-
break:rigorous
  ENDIF
ENDIF
IF ((tabw1 + tabw2) > 130cm)
  IF (or = "center")
    ATTR "Name" x:114.0cm y:(taby1 + (tabh2 / 2)) w:c:(tabw1) h:c:(tabh2)
line-break:rigorous
  ELSIF (or = "top")
    ATTR "Name" x:114.0cm y:(taby1) w:c:(tabw1) h:t:(tabh2) line-
break:rigorous
  ELSE
    ATTR "Name" x:114.0cm y:(taby2) w:c:(tabw1) h:b:(tabh2) line-
break:rigorous
  ENDIF
ENDIF
ENDIF
```

```

    IF ((tabw1 + tabw2) > 150cm)
      IF (or = "center")
        ATTR "Name" x:133.0cm y:(taby1 + (tabh2 / 2)) w:c:(tabw1) h:c:(tabh2)
line-break:rigorous
      ELSIF (or = "top")
        ATTR "Name" x:133.0cm y:(taby1) w:c:(tabw1) h:t:(tabh2) line-
break:rigorous
      ELSE
        ATTR "Name" x:133.0cm y:(taby2) w:c:(tabw1) h:b:(tabh2) line-
break:rigorous
      ENDIF
    ENDIF
    IF ((tabw1 + tabw2) > 170cm)
      IF (or = "center")
        ATTR "Name" x:152.0cm y:(taby1 + (tabh2 / 2)) w:c:(tabw1) h:c:(tabh2)
line-break:rigorous
      ELSIF (or = "top")
        ATTR "Name" x:152.0cm y:(taby1) w:c:(tabw1) h:t:(tabh2) line-
break:rigorous
      ELSE
        ATTR "Name" x:152.0cm y:(taby2) w:c:(tabw1) h:b:(tabh2) line-
break:rigorous
      ENDIF
    ENDIF
    IF ((tabw1 + tabw2) > 190cm)
      IF (or = "center")
        ATTR "Name" x:171.0cm y:(taby1 + (tabh2 / 2)) w:c:(tabw1) h:c:(tabh2)
line-break:rigorous
      ELSIF (or = "top")
        ATTR "Name" x:171.0cm y:(taby1) w:c:(tabw1) h:t:(tabh2) line-
break:rigorous
      ELSE
        ATTR "Name" x:171.0cm y:(taby2) w:c:(tabw1) h:b:(tabh2) line-
break:rigorous
      ENDIF
    ENDIF
    IF ((tabw1 + tabw2) > 210cm)
      IF (or = "center")
        ATTR "Name" x:190.0cm y:(taby1 + (tabh2 / 2)) w:c:(tabw1) h:c:(tabh2)
line-break:rigorous
      ELSIF (or = "top")
        ATTR "Name" x:190.0cm y:(taby1) w:c:(tabw1) h:t:(tabh2) line-
break:rigorous
      ELSE
        ATTR "Name" x:190.0cm y:(taby2) w:c:(tabw1) h:b:(tabh2) line-
break:rigorous
      ENDIF
    ENDIF
    IF ((tabw1 + tabw2) > 230cm)
      IF (or = "center")
        ATTR "Name" x:209.0cm y:(taby1 + (tabh2 / 2)) w:c:(tabw1) h:c:(tabh2)
line-break:rigorous
      ELSIF (or = "top")
        ATTR "Name" x:209.0cm y:(taby1) w:c:(tabw1) h:t:(tabh2) line-
break:rigorous
      ELSE
        ATTR "Name" x:209.0cm y:(taby2) w:c:(tabw1) h:b:(tabh2) line-
break:rigorous
      ENDIF
    ENDIF
  ENDIF
ENDIF

```

Part IV

```
ELSE
  IF (or = "center")
    ATTR "Bezeichnung" x:(tabx0 + (tabw1 / 2)) y:(taby1 + (tabh2 / 2))
w:c:(tabw1) h:c:(tabh2) line-break:rigorous
  ELSIF (or = "top")
    ATTR "Bezeichnung" x:(tabx0 + (tabw1 / 2)) y:(taby1) w:c:(tabw1) h:t:(tabh2)
line-break:rigorous
  ELSE
    ATTR "Bezeichnung" x:(tabx0 + (tabw1 / 2)) y:(taby2) w:c:(tabw1) h:b:(tabh2)
line-break:rigorous
  ENDIF
  IF (w="yes")
    IF ((tabw1 + tabw2) > 30cm)
      SET cl:$b5b5b5
      FONT color:(cl) h:14pt bold
      IF (or = "center")
        ATTR "Bezeichnung" x:19.0cm y:(taby1 + (tabh2 / 2)) w:c:(tabw1)
h:c:(tabh2) line-break:rigorous
      ELSIF (or = "top")
        ATTR "Bezeichnung" x:19.0cm y:(taby1) w:c:(tabw1) h:t:(tabh2) line-
break:rigorous
      ELSE
        ATTR "Bezeichnung" x:19.0cm y:(taby2) w:c:(tabw1) h:b:(tabh2) line-
break:rigorous
      ENDIF
    ENDIF
    IF ((tabw1 + tabw2) > 50cm)
      IF (or = "center")
        ATTR "Bezeichnung" x:38.0cm y:(taby1 + (tabh2 / 2)) w:c:(tabw1)
h:c:(tabh2) line-break:rigorous
      ELSIF (or = "top")
        ATTR "Bezeichnung" x:38.0cm y:(taby1) w:c:(tabw1) h:t:(tabh2) line-
break:rigorous
      ELSE
        ATTR "Bezeichnung" x:38.0cm y:(taby2) w:c:(tabw1) h:b:(tabh2) line-
break:rigorous
      ENDIF
    ENDIF
    IF ((tabw1 + tabw2) > 70cm)
      IF (or = "center")
        ATTR "Bezeichnung" x:57.0cm y:(taby1 + (tabh2 / 2)) w:c:(tabw1)
h:c:(tabh2) line-break:rigorous
      ELSIF (or = "top")
        ATTR "Bezeichnung" x:57.0cm y:(taby1) w:c:(tabw1) h:t:(tabh2) line-
break:rigorous
      ELSE
        ATTR "Bezeichnung" x:57.0cm y:(taby2) w:c:(tabw1) h:b:(tabh2) line-
break:rigorous
      ENDIF
    ENDIF
    IF ((tabw1 + tabw2) > 90cm)
      IF (or = "center")
        ATTR "Bezeichnung" x:76.0cm y:(taby1 + (tabh2 / 2)) w:c:(tabw1)
h:c:(tabh2) line-break:rigorous
      ELSIF (or = "top")
        ATTR "Bezeichnung" x:76.0cm y:(taby1) w:c:(tabw1) h:t:(tabh2) line-
break:rigorous
      ELSE
        ATTR "Bezeichnung" x:76.0cm y:(taby2) w:c:(tabw1) h:b:(tabh2) line-
break:rigorous
      ENDIF
    ENDIF
  ENDIF

```



```

ENDIF
IF ((tabw1 + tabw2) > 110cm)
  IF (or = "center")
    ATTR "Bezeichnung" x:95.0cm y:(taby1 + (tabh2 / 2)) w:c:(tabw1)
h:c:(tabh2) line-break:rigorous
  ELSIF (or = "top")
    ATTR "Bezeichnung" x:95.0cm y:(taby1) w:c:(tabw1) h:t:(tabh2) line-
break:rigorous
  ELSE
    ATTR "Bezeichnung" x:95.0cm y:(taby2) w:c:(tabw1) h:b:(tabh2) line-
break:rigorous
  ENDIF
ENDIF
IF ((tabw1 + tabw2) > 130cm)
  IF (or = "center")
    ATTR "Bezeichnung" x:114.0cm y:(taby1 + (tabh2 / 2)) w:c:(tabw1)
h:c:(tabh2) line-break:rigorous
  ELSIF (or = "top")
    ATTR "Bezeichnung" x:114.0cm y:(taby1) w:c:(tabw1) h:t:(tabh2) line-
break:rigorous
  ELSE
    ATTR "Bezeichnung" x:114.0cm y:(taby2) w:c:(tabw1) h:b:(tabh2) line-
break:rigorous
  ENDIF
ENDIF
IF ((tabw1 + tabw2) > 150cm)
  IF (or = "center")
    ATTR "Bezeichnung" x:133.0cm y:(taby1 + (tabh2 / 2)) w:c:(tabw1)
h:c:(tabh2) line-break:rigorous
  ELSIF (or = "top")
    ATTR "Bezeichnung" x:133.0cm y:(taby1) w:c:(tabw1) h:t:(tabh2) line-
break:rigorous
  ELSE
    ATTR "Bezeichnung" x:133.0cm y:(taby2) w:c:(tabw1) h:b:(tabh2) line-
break:rigorous
  ENDIF
ENDIF
IF ((tabw1 + tabw2) > 170cm)
  IF (or = "center")
    ATTR "Bezeichnung" x:152.0cm y:(taby1 + (tabh2 / 2)) w:c:(tabw1)
h:c:(tabh2) line-break:rigorous
  ELSIF (or = "top")
    ATTR "Bezeichnung" x:152.0cm y:(taby1) w:c:(tabw1) h:t:(tabh2) line-
break:rigorous
  ELSE
    ATTR "Bezeichnung" x:152.0cm y:(taby2) w:c:(tabw1) h:b:(tabh2) line-
break:rigorous
  ENDIF
ENDIF
IF ((tabw1 + tabw2) > 190cm)
  IF (or = "center")
    ATTR "Bezeichnung" x:171.0cm y:(taby1 + (tabh2 / 2)) w:c:(tabw1)
h:c:(tabh2) line-break:rigorous
  ELSIF (or = "top")
    ATTR "Bezeichnung" x:171.0cm y:(taby1) w:c:(tabw1) h:t:(tabh2) line-
break:rigorous
  ELSE
    ATTR "Bezeichnung" x:171.0cm y:(taby2) w:c:(tabw1) h:b:(tabh2) line-
break:rigorous
  ENDIF
ENDIF
ENDIF

```

Part IV

```
        IF ((tabw1 + tabw2) > 210cm)
            IF (or = "center")
                ATTR "Bezeichnung" x:190.0cm y:(taby1 + (tabh2 / 2)) w:c:(tabw1)
h:c:(tabh2) line-break:rigorous
            ELSIF (or = "top")
                ATTR "Bezeichnung" x:190.0cm y:(taby1) w:c:(tabw1) h:t:(tabh2) line-
break:rigorous
            ELSE
                ATTR "Bezeichnung" x:190.0cm y:(taby2) w:c:(tabw1) h:b:(tabh2) line-
break:rigorous
            ENDIF
        ENDIF
        IF ((tabw1 + tabw2) > 230cm)
            IF (or = "center")
                ATTR "Bezeichnung" x:209.0cm y:(taby1 + (tabh2 / 2)) w:c:(tabw1)
h:c:(tabh2) line-break:rigorous
            ELSIF (or = "top")
                ATTR "Bezeichnung" x:209.0cm y:(taby1) w:c:(tabw1) h:t:(tabh2) line-
break:rigorous
            ELSE
                ATTR "Bezeichnung" x:209.0cm y:(taby2) w:c:(tabw1) h:b:(tabh2) line-
break:rigorous
            ENDIF
        ENDIF
    ENDIF
ENDIF
ENDIF
ENDIF
AVAL set-default:"_undefined_" sHelp:"Name"
IF (sHelp = "_undefined_")
    LINE x1:2.0cm y1:0.0cm x2:2.0cm y2:4.0cm
ELSE
    LINE x1:(tabx1) y1:(taby0) x2:(tabx1) y2:(taby3)
ENDIF
```

1.1.22 Class "Swimlane (vertical)"

ADONIS BPMS BP Library 3.9:

```
GRAPHREP swimlane:vertical layer:-3
SHADOW off
AVAL sName_de:"Name"
AVAL sName_en:"Bezeichnung"
AVAL o:"Working environment"
AVAL refIT:"Referenced IT system elements"
PEN style:null
AVAL set-default:"$ffffff" c:"Color"
AVAL cl:"Fontcolor"
AVAL or:"Alignment"
AVAL w:"Display water marks"
AVAL sp:"Language"
IF (sp = "System")
    IF (_uilang = "de")
        SET sp:"German"
    ELSE
        SET sp:"English"
    ENDIF
ENDIF
ENDIF
FILL color:(rgbval (c))
PEN color:black
```

```

RECTANGLE w:4cm h:6cm
TABLE rows:2 cols:3 w:4cm h:6cm h1:4cm h2:100% w1:.1cm w2:100% w3:.1cm
STRETCH off
FONT color:(col) h:14pt bold
IF (sp = "English")
  AVAL set-format:"%o" sInterrefText:"Working environment"
  AVAL set-format:"%o" sInterrefText_2:"Referenced IT system elements"
ELSE
  AVAL sInterrefText:"refObjectNameDE"
  AVAL as-original-type sInterrefText_2:"refObjectNameDE_2"
ENDIF
IF (token(sInterrefText, 0, "-") = "[aleo]")
  SET sInterrefText:(cond(sp="English", sName_en, sName_de))
ENDIF
IF (token(sInterrefText_2, 0, "-") = "[aleo]")
  SET sInterrefText_2:(cond(sp="English", sName_en, sName_de))
ENDIF
IF (o != "")
  IF (or = "center")
    ATTR "Working environment" text:(sInterrefText) format:"%o" x:(tabx1 + (tabw2 /
2)) y:(taby0 + tabh1 / 2) w:c:(tabw2) h:c:(tabh1) line-break:rigorous
    ELSIF (or = "left")
      ATTR "Working environment" text:(sInterrefText) format:"%o" x:(tabx1) y:(taby0
+ tabh1 / 2) w:l:(tabw2) h:c:(tabh1) line-break:rigorous
    ELSE
      ATTR "Working environment" text:(sInterrefText) format:"%o" x:(tabx2) y:(taby0
+ tabh1 / 2) w:r:(tabw2) h:c:(tabh1) line-break:rigorous
    ENDIF
    IF (w="yes")
      IF ((tabh1 + tabh2) > 20cm)
        SET cl:$b5b5b5
        FONT color:(cl) h:14pt bold
        IF (or = "center")
          ATTR "Working environment" text:(sInterrefText) format:"%o" x:(tabx1 +
(tabw2 / 2)) y:14cm w:c:(tabw2) h:c:(tabh1) line-break:rigorous
          ELSIF (or = "left")
            ATTR "Working environment" text:(sInterrefText) format:"%o" x:(tabx1)
y:14cm w:l:(tabw2) h:c:(tabh1) line-break:rigorous
          ELSE
            ATTR "Working environment" text:(sInterrefText) format:"%o" x:(tabx2)
y:14cm w:r:(tabw2) h:c:(tabh1) line-break:rigorous
          ENDIF
        ENDIF
        IF ((tabh1 + tabh2) > 35cm)
          IF (or = "center")
            ATTR "Working environment" text:(sInterrefText) format:"%o" x:(tabx1 +
(tabw2 / 2)) y:28cm w:c:(tabw2) h:c:(tabh1) line-break:rigorous
            ELSIF (or = "left")
              ATTR "Working environment" text:(sInterrefText) format:"%o" x:(tabx1)
y:28cm w:l:(tabw2) h:c:(tabh1) line-break:rigorous
            ELSE
              ATTR "Working environment" text:(sInterrefText) format:"%o" x:(tabx2)
y:28cm w:r:(tabw2) h:c:(tabh1) line-break:rigorous
            ENDIF
          ENDIF
          IF ((tabh1 + tabh2) > 50cm)
            IF (or = "center")
              ATTR "Working environment" text:(sInterrefText) format:"%o" x:(tabx1 +
(tabw2 / 2)) y:42cm w:c:(tabw2) h:c:(tabh1) line-break:rigorous
              ELSIF (or = "left")

```

Part IV

```
ATTR "Working environment" text:(sInterrefText) format:"%o" x:(tabx1)
y:42cm w:l:(tabw2) h:c:(tabh1) line-break:rigorous
ELSE
ATTR "Working environment" text:(sInterrefText) format:"%o" x:(tabx2)
y:42cm w:r:(tabw2) h:c:(tabh1) line-break:rigorous
ENDIF
ENDIF
IF ((tabh1 + tabh2) > 65cm)
IF (or = "center")
ATTR "Working environment" text:(sInterrefText) format:"%o" x:(tabx1 +
(tabw2 / 2)) y:56cm w:c:(tabw2) h:c:(tabh1) line-break:rigorous
ELSIF (or = "left")
ATTR "Working environment" text:(sInterrefText) format:"%o" x:(tabx1)
y:56cm w:l:(tabw2) h:c:(tabh1) line-break:rigorous
ELSE
ATTR "Working environment" text:(sInterrefText) format:"%o" x:(tabx2)
y:56cm w:r:(tabw2) h:c:(tabh1) line-break:rigorous
ENDIF
ENDIF
IF ((tabh1 + tabh2) > 80cm)
IF (or = "center")
ATTR "Working environment" text:(sInterrefText) format:"%o" x:(tabx1 +
(tabw2 / 2)) y:70cm w:c:(tabw2) h:c:(tabh1) line-break:rigorous
ELSIF (or = "left")
ATTR "Working environment" text:(sInterrefText) format:"%o" x:(tabx1)
y:70cm w:l:(tabw2) h:c:(tabh1) line-break:rigorous
ELSE
ATTR "Working environment" text:(sInterrefText) format:"%o" x:(tabx2)
y:70cm w:r:(tabw2) h:c:(tabh1) line-break:rigorous
ENDIF
ENDIF
IF ((tabh1 + tabh2) > 95cm)
IF (or = "center")
ATTR "Working environment" text:(sInterrefText) format:"%o" x:(tabx1 +
(tabw2 / 2)) y:84cm w:c:(tabw2) h:c:(tabh1) line-break:rigorous
ELSIF (or = "left")
ATTR "Working environment" text:(sInterrefText) format:"%o" x:(tabx1)
y:84cm w:l:(tabw2) h:c:(tabh1) line-break:rigorous
ELSE
ATTR "Working environment" text:(sInterrefText) format:"%o" x:(tabx2)
y:84cm w:r:(tabw2) h:c:(tabh1) line-break:rigorous
ENDIF
ENDIF
IF ((tabh1 + tabh2) > 110cm)
IF (or = "center")
ATTR "Working environment" text:(sInterrefText) format:"%o" x:(tabx1 +
(tabw2 / 2)) y:98cm w:c:(tabw2) h:c:(tabh1) line-break:rigorous
ELSIF (or = "left")
ATTR "Working environment" text:(sInterrefText) format:"%o" x:(tabx1)
y:98cm w:l:(tabw2) h:c:(tabh1) line-break:rigorous
ELSE
ATTR "Working environment" text:(sInterrefText) format:"%o" x:(tabx2)
y:98cm w:r:(tabw2) h:c:(tabh1) line-break:rigorous
ENDIF
ENDIF
IF ((tabh1 + tabh2) > 125cm)
IF (or = "center")
ATTR "Working environment" text:(sInterrefText) format:"%o" x:(tabx1 +
(tabw2 / 2)) y:112cm w:c:(tabw2) h:c:(tabh1) line-break:rigorous
ELSIF (or = "left")
```

```

        ATTR "Working environment" text:(sInterrefText) format:"%o" x:(tabx1)
y:112cm w:l:(tabw2) h:c:(tabh1) line-break:rigorous
    ELSE
        ATTR "Working environment" text:(sInterrefText) format:"%o" x:(tabx2)
y:112cm w:r:(tabw2) h:c:(tabh1) line-break:rigorous
    ENDIF
ENDIF
IF ((tabh1 + tabh2) > 140cm)
    IF (or = "center")
        ATTR "Working environment" text:(sInterrefText) format:"%o" x:(tabx1 +
(tabw2 / 2)) y:126cm w:c:(tabw2) h:c:(tabh1) line-break:rigorous
    ELSIF (or = "left")
        ATTR "Working environment" text:(sInterrefText) format:"%o" x:(tabx1)
y:126cm w:l:(tabw2) h:c:(tabh1) line-break:rigorous
    ELSE
        ATTR "Working environment" text:(sInterrefText) format:"%o" x:(tabx2)
y:126cm w:r:(tabw2) h:c:(tabh1) line-break:rigorous
    ENDIF
ENDIF
IF ((tabh1 + tabh2) > 155cm)
    IF (or = "center")
        ATTR "Working environment" text:(sInterrefText) format:"%o" x:(tabx1 +
(tabw2 / 2)) y:140cm w:c:(tabw2) h:c:(tabh1) line-break:rigorous
    ELSIF (or = "left")
        ATTR "Working environment" text:(sInterrefText) format:"%o" x:(tabx1)
y:140cm w:l:(tabw2) h:c:(tabh1) line-break:rigorous
    ELSE
        ATTR "Working environment" text:(sInterrefText) format:"%o" x:(tabx2)
y:140cm w:r:(tabw2) h:c:(tabh1) line-break:rigorous
    ENDIF
ENDIF
IF ((tabh1 + tabh2) > 170cm)
    IF (or = "center")
        ATTR "Working environment" text:(sInterrefText) format:"%o" x:(tabx1 +
(tabw2 / 2)) y:154cm w:c:(tabw2) h:c:(tabh1) line-break:rigorous
    ELSIF (or = "left")
        ATTR "Working environment" text:(sInterrefText) format:"%o" x:(tabx1)
y:154cm w:l:(tabw2) h:c:(tabh1) line-break:rigorous
    ELSE
        ATTR "Working environment" text:(sInterrefText) format:"%o" x:(tabx2)
y:154cm w:r:(tabw2) h:c:(tabh1) line-break:rigorous
    ENDIF
ENDIF
ENDIF
ELSIF (refIT != "")
    IF (or = "center")
        ATTR "Referenced IT system elements" text:(sInterrefText_2) format:"%o"
x:(tabx1 + (tabw2 / 2)) y:(taby0 + tabh1 / 2) w:c:(tabw2) h:c:(tabh1) line-
break:rigorous
    ELSIF (or = "left")
        ATTR "Referenced IT system elements" text:(sInterrefText_2) format:"%o"
x:(tabx1) y:(taby0 + tabh1 / 2) w:l:(tabw2) h:c:(tabh1) line-break:rigorous
    ELSE
        ATTR "Referenced IT system elements" text:(sInterrefText_2) format:"%o"
x:(tabx2) y:(taby0 + tabh1 / 2) w:r:(tabw2) h:c:(tabh1) line-break:rigorous
    ENDIF
    IF (w="yes")
        IF ((tabh1 + tabh2) > 20cm)
            SET c1:$b5b5b5
            FONT color:(c1) h:14pt bold
            IF (or = "center")

```

Part IV

```
ATTR "Referenced IT system elements" text:(sInterrefText_2) format:"%o"
x:(tabx1 + (tabw2 / 2)) y:14cm w:c:(tabw2) h:c:(tabh1) line-break:rigorous
ELSIF (or = "left")
ATTR "Referenced IT system elements" text:(sInterrefText_2) format:"%o"
x:(tabx1) y:14cm w:l:(tabw2) h:c:(tabh1) line-break:rigorous
ELSE
ATTR "Referenced IT system elements" text:(sInterrefText_2) format:"%o"
x:(tabx2) y:14cm w:r:(tabw2) h:c:(tabh1) line-break:rigorous
ENDIF
ENDIF
IF ((tabh1 + tabh2) > 35cm)
IF (or = "center")
ATTR "Referenced IT system elements" text:(sInterrefText_2) format:"%o"
x:(tabx1 + (tabw2 / 2)) y:28cm w:c:(tabw2) h:c:(tabh1) line-break:rigorous
ELSIF (or = "left")
ATTR "Referenced IT system elements" text:(sInterrefText_2) format:"%o"
x:(tabx1) y:28cm w:l:(tabw2) h:c:(tabh1) line-break:rigorous
ELSE
ATTR "Referenced IT system elements" text:(sInterrefText_2) format:"%o"
x:(tabx2) y:28cm w:r:(tabw2) h:c:(tabh1) line-break:rigorous
ENDIF
ENDIF
IF ((tabh1 + tabh2) > 50cm)
IF (or = "center")
ATTR "Referenced IT system elements" text:(sInterrefText_2) format:"%o"
x:(tabx1 + (tabw2 / 2)) y:42cm w:c:(tabw2) h:c:(tabh1) line-break:rigorous
ELSIF (or = "left")
ATTR "Referenced IT system elements" text:(sInterrefText_2) format:"%o"
x:(tabx1) y:42cm w:l:(tabw2) h:c:(tabh1) line-break:rigorous
ELSE
ATTR "Referenced IT system elements" text:(sInterrefText_2) format:"%o"
x:(tabx2) y:42cm w:r:(tabw2) h:c:(tabh1) line-break:rigorous
ENDIF
ENDIF
IF ((tabh1 + tabh2) > 65cm)
IF (or = "center")
ATTR "Referenced IT system elements" text:(sInterrefText_2) format:"%o"
x:(tabx1 + (tabw2 / 2)) y:56cm w:c:(tabw2) h:c:(tabh1) line-break:rigorous
ELSIF (or = "left")
ATTR "Referenced IT system elements" text:(sInterrefText_2) format:"%o"
x:(tabx1) y:56cm w:l:(tabw2) h:c:(tabh1) line-break:rigorous
ELSE
ATTR "Referenced IT system elements" text:(sInterrefText_2) format:"%o"
x:(tabx2) y:56cm w:r:(tabw2) h:c:(tabh1) line-break:rigorous
ENDIF
ENDIF
IF ((tabh1 + tabh2) > 80cm)
IF (or = "center")
ATTR "Referenced IT system elements" text:(sInterrefText_2) format:"%o"
x:(tabx1 + (tabw2 / 2)) y:70cm w:c:(tabw2) h:c:(tabh1) line-break:rigorous
ELSIF (or = "left")
ATTR "Referenced IT system elements" text:(sInterrefText_2) format:"%o"
x:(tabx1) y:70cm w:l:(tabw2) h:c:(tabh1) line-break:rigorous
ELSE
ATTR "Referenced IT system elements" text:(sInterrefText_2) format:"%o"
x:(tabx2) y:70cm w:r:(tabw2) h:c:(tabh1) line-break:rigorous
ENDIF
ENDIF
IF ((tabh1 + tabh2) > 95cm)
IF (or = "center")
```

```

        ATTR "Referenced IT system elements" text:(sInterrefText_2) format:"%o"
x:(tabx1 + (tabw2 / 2)) y:84cm w:c:(tabw2) h:c:(tabh1) line-break:rigorous
        ELSIF (or = "left")
        ATTR "Referenced IT system elements" text:(sInterrefText_2) format:"%o"
x:(tabx1) y:84cm w:l:(tabw2) h:c:(tabh1) line-break:rigorous
        ELSE
        ATTR "Referenced IT system elements" text:(sInterrefText_2) format:"%o"
x:(tabx2) y:84cm w:r:(tabw2) h:c:(tabh1) line-break:rigorous
        ENDIF
    ENDIF
    IF ((tabh1 + tabh2) > 110cm)
        IF (or = "center")
        ATTR "Referenced IT system elements" text:(sInterrefText_2) format:"%o"
x:(tabx1 + (tabw2 / 2)) y:98cm w:c:(tabw2) h:c:(tabh1) line-break:rigorous
        ELSIF (or = "left")
        ATTR "Referenced IT system elements" text:(sInterrefText_2) format:"%o"
x:(tabx1) y:98cm w:l:(tabw2) h:c:(tabh1) line-break:rigorous
        ELSE
        ATTR "Referenced IT system elements" text:(sInterrefText_2) format:"%o"
x:(tabx2) y:98cm w:r:(tabw2) h:c:(tabh1) line-break:rigorous
        ENDIF
    ENDIF
    IF ((tabh1 + tabh2) > 125cm)
        IF (or = "center")
        ATTR "Referenced IT system elements" text:(sInterrefText_2) format:"%o"
x:(tabx1 + (tabw2 / 2)) y:112cm w:c:(tabw2) h:c:(tabh1) line-break:rigorous
        ELSIF (or = "left")
        ATTR "Referenced IT system elements" text:(sInterrefText_2) format:"%o"
x:(tabx1) y:112cm w:l:(tabw2) h:c:(tabh1) line-break:rigorous
        ELSE
        ATTR "Referenced IT system elements" text:(sInterrefText_2) format:"%o"
x:(tabx2) y:112cm w:r:(tabw2) h:c:(tabh1) line-break:rigorous
        ENDIF
    ENDIF
    IF ((tabh1 + tabh2) > 140cm)
        IF (or = "center")
        ATTR "Referenced IT system elements" text:(sInterrefText_2) format:"%o"
x:(tabx1 + (tabw2 / 2)) y:126cm w:c:(tabw2) h:c:(tabh1) line-break:rigorous
        ELSIF (or = "left")
        ATTR "Referenced IT system elements" text:(sInterrefText_2) format:"%o"
x:(tabx1) y:126cm w:l:(tabw2) h:c:(tabh1) line-break:rigorous
        ELSE
        ATTR "Referenced IT system elements" text:(sInterrefText_2) format:"%o"
x:(tabx2) y:126cm w:r:(tabw2) h:c:(tabh1) line-break:rigorous
        ENDIF
    ENDIF
    IF ((tabh1 + tabh2) > 155cm)
        IF (or = "center")
        ATTR "Referenced IT system elements" text:(sInterrefText_2) format:"%o"
x:(tabx1 + (tabw2 / 2)) y:140cm w:c:(tabw2) h:c:(tabh1) line-break:rigorous
        ELSIF (or = "left")
        ATTR "Referenced IT system elements" text:(sInterrefText_2) format:"%o"
x:(tabx1) y:140cm w:l:(tabw2) h:c:(tabh1) line-break:rigorous
        ELSE
        ATTR "Referenced IT system elements" text:(sInterrefText_2) format:"%o"
x:(tabx2) y:140cm w:r:(tabw2) h:c:(tabh1) line-break:rigorous
        ENDIF
    ENDIF
    IF ((tabh1 + tabh2) > 170cm)
        IF (or = "center")

```

Part IV

```
ATTR "Referenced IT system elements" text:(sInterrefText_2) format:"%o"
x:(tabx1 + (tabw2 / 2)) y:154cm w:c:(tabw2) h:c:(tabh1) line-break:rigorous
ELSIF (or = "left")
ATTR "Referenced IT system elements" text:(sInterrefText_2) format:"%o"
x:(tabx1) y:154cm w:l:(tabw2) h:c:(tabh1) line-break:rigorous
ELSE
ATTR "Referenced IT system elements" text:(sInterrefText_2) format:"%o"
x:(tabx2) y:154cm w:r:(tabw2) h:c:(tabh1) line-break:rigorous
ENDIF
ENDIF
ENDIF
ELSE
IF (sp = "English")
IF (or = "center")
ATTR "Name" x:(tabx1 + (tabw2 / 2)) y:(taby0 + tabh1 / 2) w:c:(tabw2)
h:c:(tabh1) line-break:rigorous
ELSIF (or = "left")
ATTR "Name" x:(tabx1) y:(taby0 + tabh1 / 2) w:l:(tabw2) h:c:(tabh1) line-
break:rigorous
ELSE
ATTR "Name" x:(tabx2) y:(taby0 + tabh1 / 2) w:r:(tabw2) h:c:(tabh1) line-
break:rigorous
ENDIF
IF (w="yes")
IF ((tabh1 + tabh2) > 20cm)
SET cl:$b5b5b5
FONT color:(cl) h:14pt bold
IF (or = "center")
ATTR "Name" x:(tabx1 + (tabw2 / 2)) y:14cm w:c:(tabw2) h:c:(tabh1) line-
break:rigorous
ELSIF (or = "left")
ATTR "Name" x:(tabx1) y:14cm w:l:(tabw2) h:c:(tabh1) line-break:rigorous
ELSE
ATTR "Name" x:(tabx2) y:14cm w:r:(tabw2) h:c:(tabh1) line-break:rigorous
ENDIF
ENDIF
IF ((tabh1 + tabh2) > 35cm)
IF (or = "center")
ATTR "Name" x:(tabx1 + (tabw2 / 2)) y:28cm w:c:(tabw2) h:c:(tabh1) line-
break:rigorous
ELSIF (or = "left")
ATTR "Name" x:(tabx1) y:28cm w:l:(tabw2) h:c:(tabh1) line-break:rigorous
ELSE
ATTR "Name" x:(tabx2) y:28cm w:r:(tabw2) h:c:(tabh1) line-break:rigorous
ENDIF
ENDIF
IF ((tabh1 + tabh2) > 50cm)
IF (or = "center")
ATTR "Name" x:(tabx1 + (tabw2 / 2)) y:42cm w:c:(tabw2) h:c:(tabh1) line-
break:rigorous
ELSIF (or = "left")
ATTR "Name" x:(tabx1) y:42cm w:l:(tabw2) h:c:(tabh1) line-break:rigorous
ELSE
ATTR "Name" x:(tabx2) y:42cm w:r:(tabw2) h:c:(tabh1) line-break:rigorous
ENDIF
ENDIF
IF ((tabh1 + tabh2) > 65cm)
IF (or = "center")
ATTR "Name" x:(tabx1 + (tabw2 / 2)) y:56cm w:c:(tabw2) h:c:(tabh1) line-
break:rigorous
ELSIF (or = "left")
```



```

        ATTR "Name" x:(tabx1) y:56cm w:l:(tabw2) h:c:(tabh1) line-break:rigorous
    ELSE
        ATTR "Name" x:(tabx2) y:56cm w:r:(tabw2) h:c:(tabh1) line-break:rigorous
    ENDIF
ENDIF
IF ((tabh1 + tabh2) > 80cm)
    IF (or = "center")
        ATTR "Name" x:(tabx1 + (tabw2 / 2)) y:70cm w:c:(tabw2) h:c:(tabh1) line-
break:rigorous
    ELSIF (or = "left")
        ATTR "Name" x:(tabx1) y:70cm w:l:(tabw2) h:c:(tabh1) line-break:rigorous
    ELSE
        ATTR "Name" x:(tabx2) y:70cm w:r:(tabw2) h:c:(tabh1) line-break:rigorous
    ENDIF
ENDIF
IF ((tabh1 + tabh2) > 95cm)
    IF (or = "center")
        ATTR "Name" x:(tabx1 + (tabw2 / 2)) y:84cm w:c:(tabw2) h:c:(tabh1) line-
break:rigorous
    ELSIF (or = "left")
        ATTR "Name" x:(tabx1) y:84cm w:l:(tabw2) h:c:(tabh1) line-break:rigorous
    ELSE
        ATTR "Name" x:(tabx2) y:84cm w:r:(tabw2) h:c:(tabh1) line-break:rigorous
    ENDIF
ENDIF
IF ((tabh1 + tabh2) > 110cm)
    IF (or = "center")
        ATTR "Name" x:(tabx1 + (tabw2 / 2)) y:98cm w:c:(tabw2) h:c:(tabh1) line-
break:rigorous
    ELSIF (or = "left")
        ATTR "Name" x:(tabx1) y:98cm w:l:(tabw2) h:c:(tabh1) line-break:rigorous
    ELSE
        ATTR "Name" x:(tabx2) y:98cm w:r:(tabw2) h:c:(tabh1) line-break:rigorous
    ENDIF
ENDIF
IF ((tabh1 + tabh2) > 125cm)
    IF (or = "center")
        ATTR "Name" x:(tabx1 + (tabw2 / 2)) y:112cm w:c:(tabw2) h:c:(tabh1) line-
break:rigorous
    ELSIF (or = "left")
        ATTR "Name" x:(tabx1) y:112cm w:l:(tabw2) h:c:(tabh1) line-break:rigorous
    ELSE
        ATTR "Name" x:(tabx2) y:112cm w:r:(tabw2) h:c:(tabh1) line-break:rigorous
    ENDIF
ENDIF
IF ((tabh1 + tabh2) > 140cm)
    IF (or = "center")
        ATTR "Name" x:(tabx1 + (tabw2 / 2)) y:126cm w:c:(tabw2) h:c:(tabh1) line-
break:rigorous
    ELSIF (or = "left")
        ATTR "Name" x:(tabx1) y:126cm w:l:(tabw2) h:c:(tabh1) line-break:rigorous
    ELSE
        ATTR "Name" x:(tabx2) y:126cm w:r:(tabw2) h:c:(tabh1) line-break:rigorous
    ENDIF
ENDIF
IF ((tabh1 + tabh2) > 155cm)
    IF (or = "center")
        ATTR "Name" x:(tabx1 + (tabw2 / 2)) y:140cm w:c:(tabw2) h:c:(tabh1) line-
break:rigorous
    ELSIF (or = "left")
        ATTR "Name" x:(tabx1) y:140cm w:l:(tabw2) h:c:(tabh1) line-break:rigorous

```

Part IV

```
ELSE
  ATTR "Name" x:(tabx2) y:140cm w:r:(tabw2) h:c:(tabh1) line-break:rigorous
ENDIF
ENDIF
IF ((tabh1 + tabh2) > 170cm)
  IF (or = "center")
    ATTR "Name" x:(tabx1 + (tabw2 / 2)) y:154cm w:c:(tabw2) h:c:(tabh1) line-
break:rigorous
  ELSIF (or = "left")
    ATTR "Name" x:(tabx1) y:154cm w:l:(tabw2) h:c:(tabh1) line-break:rigorous
  ELSE
    ATTR "Name" x:(tabx2) y:154cm w:r:(tabw2) h:c:(tabh1) line-break:rigorous
  ENDIF
ENDIF
ENDIF
ELSE
  IF (or = "center")
    ATTR "Bezeichnung" x:(tabx1 + (tabw2 / 2)) y:(taby0 + tabh1 / 2) w:c:(tabw2)
h:c:(tabh1) line-break:rigorous
  ELSIF (or = "left")
    ATTR "Bezeichnung" x:(tabx1) y:(taby0 + tabh1 / 2) w:l:(tabw2) h:c:(tabh1)
line-break:rigorous
  ELSE
    ATTR "Bezeichnung" x:(tabx2) y:(taby0 + tabh1 / 2) w:r:(tabw2) h:c:(tabh1)
line-break:rigorous
  ENDIF
  IF (w="yes")
    IF ((tabh1 + tabh2) > 20cm)
      SET cl:$b5b5b5
      FONT color:(cl) h:14pt bold
      IF (or = "center")
        ATTR "Bezeichnung" x:(tabx1 + (tabw2 / 2)) y:14cm w:c:(tabw2) h:c:(tabh1)
line-break:rigorous
      ELSIF (or = "left")
        ATTR "Bezeichnung" x:(tabx1) y:14cm w:l:(tabw2) h:c:(tabh1) line-
break:rigorous
      ELSE
        ATTR "Bezeichnung" x:(tabx2) y:14cm w:r:(tabw2) h:c:(tabh1) line-
break:rigorous
      ENDIF
    ENDIF
    IF ((tabh1 + tabh2) > 35cm)
      IF (or = "center")
        ATTR "Bezeichnung" x:(tabx1 + (tabw2 / 2)) y:28cm w:c:(tabw2) h:c:(tabh1)
line-break:rigorous
      ELSIF (or = "left")
        ATTR "Bezeichnung" x:(tabx1) y:28cm w:l:(tabw2) h:c:(tabh1) line-
break:rigorous
      ELSE
        ATTR "Bezeichnung" x:(tabx2) y:28cm w:r:(tabw2) h:c:(tabh1) line-
break:rigorous
      ENDIF
    ENDIF
    IF ((tabh1 + tabh2) > 50cm)
      IF (or = "center")
        ATTR "Bezeichnung" x:(tabx1 + (tabw2 / 2)) y:42cm w:c:(tabw2) h:c:(tabh1)
line-break:rigorous
      ELSIF (or = "left")
        ATTR "Bezeichnung" x:(tabx1) y:42cm w:l:(tabw2) h:c:(tabh1) line-
break:rigorous
      ELSE

```

```

        ATTR "Bezeichnung" x:(tabx2) y:42cm w:r:(tabw2) h:c:(tabh1) line-
break:rigorous
    ENDIF
ENDIF
IF ((tabh1 + tabh2) > 65cm)
    IF (or = "center")
        ATTR "Bezeichnung" x:(tabx1 + (tabw2 / 2)) y:56cm w:c:(tabw2) h:c:(tabh1)
line-break:rigorous
        ELSIF (or = "left")
            ATTR "Bezeichnung" x:(tabx1) y:56cm w:l:(tabw2) h:c:(tabh1) line-
break:rigorous
        ELSE
            ATTR "Bezeichnung" x:(tabx2) y:56cm w:r:(tabw2) h:c:(tabh1) line-
break:rigorous
        ENDIF
    ENDIF
ENDIF
IF ((tabh1 + tabh2) > 80cm)
    IF (or = "center")
        ATTR "Bezeichnung" x:(tabx1 + (tabw2 / 2)) y:70cm w:c:(tabw2) h:c:(tabh1)
line-break:rigorous
        ELSIF (or = "left")
            ATTR "Bezeichnung" x:(tabx1) y:70cm w:l:(tabw2) h:c:(tabh1) line-
break:rigorous
        ELSE
            ATTR "Bezeichnung" x:(tabx2) y:70cm w:r:(tabw2) h:c:(tabh1) line-
break:rigorous
        ENDIF
    ENDIF
ENDIF
IF ((tabh1 + tabh2) > 95cm)
    IF (or = "center")
        ATTR "Bezeichnung" x:(tabx1 + (tabw2 / 2)) y:84cm w:c:(tabw2) h:c:(tabh1)
line-break:rigorous
        ELSIF (or = "left")
            ATTR "Bezeichnung" x:(tabx1) y:84cm w:l:(tabw2) h:c:(tabh1) line-
break:rigorous
        ELSE
            ATTR "Bezeichnung" x:(tabx2) y:84cm w:r:(tabw2) h:c:(tabh1) line-
break:rigorous
        ENDIF
    ENDIF
ENDIF
IF ((tabh1 + tabh2) > 110cm)
    IF (or = "center")
        ATTR "Bezeichnung" x:(tabx1 + (tabw2 / 2)) y:98cm w:c:(tabw2) h:c:(tabh1)
line-break:rigorous
        ELSIF (or = "left")
            ATTR "Bezeichnung" x:(tabx1) y:98cm w:l:(tabw2) h:c:(tabh1) line-
break:rigorous
        ELSE
            ATTR "Bezeichnung" x:(tabx2) y:98cm w:r:(tabw2) h:c:(tabh1) line-
break:rigorous
        ENDIF
    ENDIF
ENDIF
IF ((tabh1 + tabh2) > 125cm)
    IF (or = "center")
        ATTR "Bezeichnung" x:(tabx1 + (tabw2 / 2)) y:112cm w:c:(tabw2)
h:c:(tabh1) line-break:rigorous
        ELSIF (or = "left")
            ATTR "Bezeichnung" x:(tabx1) y:112cm w:l:(tabw2) h:c:(tabh1) line-
break:rigorous
        ELSE

```

Part IV

```
        ATTR "Bezeichnung" x:(tabx2) y:112cm w:r:(tabw2) h:c:(tabh1) line-
break:rigorous
    ENDIF
ENDIF
IF ((tabh1 + tabh2) > 140cm)
    IF (or = "center")
        ATTR "Bezeichnung" x:(tabx1 + (tabw2 / 2)) y:126cm w:c:(tabw2)
h:c:(tabh1) line-break:rigorous
    ELSIF (or = "left")
        ATTR "Bezeichnung" x:(tabx1) y:126cm w:l:(tabw2) h:c:(tabh1) line-
break:rigorous
    ELSE
        ATTR "Bezeichnung" x:(tabx2) y:126cm w:r:(tabw2) h:c:(tabh1) line-
break:rigorous
    ENDIF
ENDIF
IF ((tabh1 + tabh2) > 155cm)
    IF (or = "center")
        ATTR "Bezeichnung" x:(tabx1 + (tabw2 / 2)) y:140cm w:c:(tabw2)
h:c:(tabh1) line-break:rigorous
    ELSIF (or = "left")
        ATTR "Bezeichnung" x:(tabx1) y:140cm w:l:(tabw2) h:c:(tabh1) line-
break:rigorous
    ELSE
        ATTR "Bezeichnung" x:(tabx2) y:140cm w:r:(tabw2) h:c:(tabh1) line-
break:rigorous
    ENDIF
ENDIF
IF ((tabh1 + tabh2) > 170cm)
    IF (or = "center")
        ATTR "Bezeichnung" x:(tabx1 + (tabw2 / 2)) y:154cm w:c:(tabw2)
h:c:(tabh1) line-break:rigorous
    ELSIF (or = "left")
        ATTR "Bezeichnung" x:(tabx1) y:154cm w:l:(tabw2) h:c:(tabh1) line-
break:rigorous
    ELSE
        ATTR "Bezeichnung" x:(tabx2) y:154cm w:r:(tabw2) h:c:(tabh1) line-
break:rigorous
    ENDIF
ENDIF
ENDIF
ENDIF
FONT
AVAL set-default:"_undefined_" sHelp:"Name"
IF (sHelp = "_undefined_")
    LINE x1:0cm y1:2.0cm x2:4.0cm y2:2.0cm
ELSE
    LINE x1:(tabx0) y1:(taby1) x2:(tabx3) y2:(taby1)
ENDIF
```

1.1.23 Class "External partner"

ADONIS BPMS BP Library 3.9:

```
GRAPHREP
SHADOW off
AVAL sp:"Language"
IF (sp = "System")
```

```

IF (_uilang = "de")
  SET sp:"German"
ELSE
  SET sp:"English"
ENDIF
ENDIF
AVAL set-default:"no" mono:"Monochrome view"
IF (mono = "yes")
  SET bMono:1
ELSE
  SET bMono:0
ENDIF
IF (bMono)
  FILL color:white
ELSE
  FILL color:darkgray
ENDIF
#-----
SET px:0.245cm
SET py:-0.76cm
SET x_factor:0.0cm
SET y_factor:0.0cm
ELLIPSE x:(px + x_factor) y:(py + y_factor) rx:.15cm ry:.15cm
ROUNDRECT x:(-0.02cm + x_factor) y:(-0.6cm + y_factor) w:0.5cm h:0.6cm rx:0.1cm
ry:0.1cm
PEN style:null
RECTANGLE x:(0.08cm + x_factor) y:(-0.3cm + y_factor) w:0.32cm h:0.63cm
PEN
LINE x1:(0.08cm + x_factor) y1:(-0.3cm + y_factor) x2:(0.08cm + x_factor)
y2:(0.34cm + y_factor)
LINE x1:(0.25cm + x_factor) y1:(0.04cm + y_factor) x2:(0.25cm + x_factor)
y2:(0.34cm + y_factor)
LINE x1:(0.4cm + x_factor) y1:(-0.3cm + y_factor) x2:(0.4cm + x_factor) y2:(0.34cm
+ y_factor)
LINE x1:(0.08cm + x_factor) y1:(0.34cm + y_factor) x2:(0.4cm + x_factor) y2:(0.34cm
+ y_factor)
#-----
IF (bMono)
  FILL color:white
ELSE
  FILL color:gray
ENDIF
SET px:0.245cm
SET py:-0.76cm
SET x_factor:-0.25cm
SET y_factor:0.07cm
ELLIPSE x:(px + x_factor) y:(py + y_factor) rx:.15cm ry:.15cm
ROUNDRECT x:(-0.02cm + x_factor) y:(-0.6cm + y_factor) w:0.5cm h:0.6cm rx:0.1cm
ry:0.1cm
PEN style:null
RECTANGLE x:(0.08cm + x_factor) y:(-0.3cm + y_factor) w:0.32cm h:0.63cm
PEN
LINE x1:(0.08cm + x_factor) y1:(-0.3cm + y_factor) x2:(0.08cm + x_factor)
y2:(0.34cm + y_factor)
LINE x1:(0.25cm + x_factor) y1:(0.04cm + y_factor) x2:(0.25cm + x_factor)
y2:(0.34cm + y_factor)
LINE x1:(0.4cm + x_factor) y1:(-0.3cm + y_factor) x2:(0.4cm + x_factor) y2:(0.34cm
+ y_factor)
LINE x1:(0.08cm + x_factor) y1:(0.34cm + y_factor) x2:(0.4cm + x_factor) y2:(0.34cm
+ y_factor)
#-----

```

Part IV

```
IF (bMono)
  FILL color:white
ELSE
  FILL color:lightgray
ENDIF
SET px:0.245cm
SET py:-0.76cm
SET x_factor:-0.5cm
SET y_factor:0.14cm
ELLIPSE x:(px + x_factor) y:(py + y_factor) rx:.15cm ry:.15cm
ROUNDRECT x:(-0.02cm + x_factor) y:(-0.6cm + y_factor) w:0.5cm h:0.6cm rx:0.1cm
ry:0.1cm
PEN style:null
RECTANGLE x:(0.08cm + x_factor) y:(-0.3cm + y_factor) w:0.32cm h:0.63cm
PEN
LINE x1:(0.08cm + x_factor) y1:(-0.3cm + y_factor) x2:(0.08cm + x_factor)
y2:(0.34cm + y_factor)
LINE x1:(0.25cm + x_factor) y1:(0.04cm + y_factor) x2:(0.25cm + x_factor)
y2:(0.34cm + y_factor)
LINE x1:(0.4cm + x_factor) y1:(-0.3cm + y_factor) x2:(0.4cm + x_factor) y2:(0.34cm
+ y_factor)
LINE x1:(0.08cm + x_factor) y1:(0.34cm + y_factor) x2:(0.4cm + x_factor) y2:(0.34cm
+ y_factor)
#-----
AVAL refOrgElem:"Referenced organizational unit"
AVAL refOrgElemDE:"refObjectNameDE"
IF (refOrgElem = "")
  IF (sp = "English")
    ATTR "Name" y:0.6cm w:c:3.00cm h:t
  ELSE
    ATTR "Bezeichnung" y:0.6cm w:c:3.00cm h:t
  ENDIF
ELSE
  IF (sp = "German")
    ATTR "Referenced organizational unit" format:"%o" y:0.6cm w:c:3.00cm h:t
  ELSE
    ATTR "Referenced organizational unit" text:(refOrgElemDE) y:0.6cm w:c:3.00cm
h:t
  ENDIF
ENDIF
ENDIF
```

1.1.24 Class "Product"

ADONIS BPMS BP Library 3.9:

```
GRAPHREP
SHADOW off
AVAL sp:"Language"
IF (sp = "System")
  IF (_uilang = "de")
    SET sp:"German"
  ELSE
    SET sp:"English"
  ENDIF
ENDIF
AVAL col:"fontcolor"
AVAL ext:"External documentation"
AVAL refDoc:"Referenced documents"
AVAL refSysMode:"Referenced product model"
```

```

AVAL set-default:"no" mono:"Monochrome view"
IF (mono = "yes")
  SET color_fill:(rgbval("black"))
  SET color_red:(rgbval("black"))
  SET color_blue:(rgbval("black"))
ELSE
  SET color_fill:(rgbval("$ff8000"))
  SET color_red:(rgbval("red"))
  SET color_blue:(rgbval("blue"))
ENDIF
FILL color:(color_fill)
PEN w:0.05cm color:(color_fill)
IF (mono = "no")
  # start - smooth shaded colors
  CLIP_ROUNDRECT x:-1.5cm y:-1.0cm w:3.0cm h:2.0cm rx:0.2cm ry:0.2cm
  GRADIENT_RECT x:-1.5cm y:-1.0cm w:3.0cm h:2.0cm style:downdiag
    color1:$ffd8b0 color2:$ee7700
  #PEN w:0.05cm
  FILL style:null
  CLIP_OFF
  # end - smooth shaded colors
ENDIF
ROUNDRECT x:-1.5cm y:-1.0cm w:3.0cm h:2.0cm rx:0.2cm ry:0.2cm
FILL color:white
RECTANGLE x:-1.5cm y:-0.5cm w:3.0cm h:1.0cm
PEN w:0.05cm color:black
FONT "Wingdings" h:15pt color:white
TEXT "u" x:1.19cm y:-0.67cm h:c w:c
IF (refSysMode != "")
  FONT "Wingdings" h:15pt color:white
  ATTR "Referenced product model" text:"P" x:1.25cm y:0.8cm h:c w:c
ENDIF
FONT color:(col)
IF (sp = "German")
  ATTR "Bezeichnung" y:1.1cm w:c:3.5cm h:t
  SET sText01:"Spez.:"
  SET sText02:"Gesamt:"
ELSE
  ATTR "Name" y:1.1cm w:c:3.5cm h:t
  SET sText01:"Spec.:"
  SET sText02:"Total:"
ENDIF
IF ( token(ext, 1, "@") != "" )
  FONT "Wingdings" h:18.0pt color:(col)
  TEXT "4" x:1.52cm y:-0.97cm w:r h:b
  HOTSPOT "External documentation" x:1.0cm y:-1.7cm w:0.5cm h:0.6cm
ELSE
  IF ( refDoc != "" )
    FONT "Wingdings" h:18.0pt color:(col)
    TEXT "4" x:1.52cm y:-0.97cm w:r h:b
    HOTSPOT "Referenced documents" x:1.0cm y:-1.7cm w:0.5cm h:0.6cm
  ENDIF
ENDIF
AVAL oF:"Open questions"
IF ( LEN(replall(replall((oF)," ",""),"
",""))>0 )
  FONT "Arial" h:10.0pt bold color:(color_red)
  TEXT "?" x:1.57cm y:-1.05cm
ENDIF
AVAL visCosts:"Display costs"
IF (visCosts = "1")

```

Part IV

```
FONT "Arial" h:9pt
TEXT (sText01) x:-1.45cm y:-0.22cm w:l h:c
ATTR "Specific costs" x:1.45cm y:-0.22cm w:r:1.7cm h:c
FONT "Arial" h:9pt bold
TEXT (sText02) x:-1.45cm y:0.22cm w:l h:c
ATTR "Total costs" x:1.45cm y:0.22cm w:r:1.7cm h:c
ENDIF
```

1.1.25 Class "Product component"

ADONIS BPMS BP Library 3.9:

```
GRAPHREP
SHADOW off
AVAL sp:"Language"
IF (sp = "System")
  IF (_uilang = "en")
    SET sp:"English"
  ELSE
    SET sp:"German"
  ENDIF
ENDIF
AVAL col:"fontcolor"
AVAL ext:"External documentation"
AVAL refDoc:"Referenced documents"
AVAL refSysMode:"Referenced product model"
AVAL set-default:"no" mono:"Monochrome view"
IF (mono = "yes")
  SET color_fill:(rgbval("black"))
  SET color_red:(rgbval("black"))
  SET color_blue:(rgbval("black"))
ELSE
  SET color_fill:(rgbval("$ffc04d"))
  SET color_red:(rgbval("red"))
  SET color_blue:(rgbval("blue"))
ENDIF
FILL color:(color_fill)
PEN w:0.05cm color:(color_fill)
IF (mono = "no")
  # start - smooth shaded colors
  CLIP_ROUNDRECT x:-1.5cm y:-1.0cm w:3.0cm h:2.0cm rx:0.2cm ry:0.2cm
  GRADIENT_RECT x:-1.5cm y:-1.0cm w:3.0cm h:2.0cm style:downdiag
    color1:white color2:(color_fill)
  #PEN w:0.05cm
  FILL style:null
  CLIP_OFF
  # end - smooth shaded colors
ENDIF
ROUNDRECT x:-1.5cm y:-1.0cm w:3.0cm h:2.0cm rx:0.2cm ry:0.2cm
FILL color:white
RECTANGLE x:-1.5cm y:-0.5cm w:3.0cm h:1.0cm
PEN w:0.05cm color:black
FONT "Wingdings" h:15pt color:white
TEXT "v" x:1.19cm y:-0.67cm h:c w:c
IF (refSysMode != "")
  FONT "Wingdings" h:15pt color:white
  ATTR "Referenced product model" text:"P" x:1.25cm y:0.8cm h:c w:c
ENDIF
FONT color:(col)
```



```

IF (sp = "English")
  ATTR "Name" y:1.1cm w:c:3.5cm h:t
  SET sText01:"Spec.:"
  SET sText02:"Total:"
ELSE
  ATTR "Bezeichnung" y:1.1cm w:c:3.5cm h:t
  SET sText01:"Spez.:"
  SET sText02:"Gesamt:"
ENDIF
IF ( token(ext, 1, "@") != "" )
  FONT "Wingdings" h:18.0pt color:(col)
  TEXT "4" x:1.52cm y:-0.97cm w:r h:b
  HOTSPOT "External documentation" x:1.0cm y:-1.7cm w:0.5cm h:0.6cm
ELSE
  IF ( refDoc != "" )
    FONT "Wingdings" h:18.0pt color:(col)
    TEXT "4" x:1.52cm y:-0.97cm w:r h:b
    HOTSPOT "Referenced documents" x:1.0cm y:-1.7cm w:0.5cm h:0.6cm
  ENDIF
ENDIF
AVAL oF:"Open questions"
IF ( LEN(replall(replall((oF), " ", ""), "
", ""))>0 )
  FONT "Arial" h:10.0pt bold color:(color_red)
  TEXT "?" x:1.57cm y:-1.05cm
ENDIF
AVAL visCosts:"Display costs"
IF (visCosts = "1")
  FONT "Arial" h:9pt
  TEXT (sText01) x:-1.45cm y:-0.22cm w:l h:c
  ATTR "Specific costs" x:1.45cm y:-0.22cm w:r:1.7cm h:c
  FONT "Arial" h:9pt bold
  TEXT (sText02) x:-1.45cm y:0.22cm w:l h:c
  ATTR "Total costs" x:1.45cm y:0.22cm w:r:1.7cm h:c
ENDIF

```

1.1.26 Class "Application"

ADONIS BPMS BP Library 3.9:

```

GRAPHREP
SHADOW off
AVAL sp:"Language"
IF (sp = "System")
  IF (_uilang = "en")
    SET sp:"English"
  ELSE
    SET sp:"German"
  ENDIF
ENDIF
AVAL str_applType:"Type of application"
AVAL str_applType_other:"Other"
AVAL col:"fontcolor"
AVAL str_bitmap:"Screenshot"
AVAL ext:"External documentation"
AVAL refDoc:"Referenced documents"
AVAL refSysMode:"Referenced IT system model"
AVAL set-default:"no" mono:"Monochrome view"
IF (mono = "yes")

```

Part IV

```
SET color_fill:(rgbval("black"))
SET color_red:(rgbval("black"))
SET color_blue:(rgbval("black"))
ELSE
SET color_fill:(rgbval("$00aa00"))
SET color_red:(rgbval("red"))
SET color_blue:(rgbval("blue"))
ENDIF
PEN w:0.05cm color:black
FILL color:(color_fill)
PEN w:0.05cm color:(color_fill)
IF (mono = "no")
# start - smooth shaded colors
CLIP_ROUNDRECT x:-1.5cm y:-1.5cm w:3.0cm h:3.0cm rx:0.2cm ry:0.2cm
GRADIENT_RECT x:-1.5cm y:-1.5cm w:3.0cm h:3.0cm style:downdiag
color1:$00c800 color2:$006c00
#PEN w:0.05cm
FILL style:null
CLIP_OFF
# end - smooth shaded colors
ENDIF
ROUNDRECT x:-1.5cm y:-1.5cm w:3.0cm h:3.0cm rx:0.2cm ry:0.2cm
FILL color:white
RECTANGLE x:-1.5cm y:-1.0cm w:3.0cm h:2.0cm
IF (refSysMode != "")
FONT "Wingdings" h:15pt color:white
TEXT "P" x:1.25cm y:1.3cm h:c w:c
ATTR "Referenced IT system model" text:"P" x:1.25cm y:1.3cm h:c w:c
ENDIF
FONT color:white h:9pt
IF (str_applType = "Other")
ATTR "Other" x:-1.45cm y:-1.23cm w:l h:c
ELSE
ATTR "Type of application" x:-1.45cm y:-1.23cm w:l h:c
#TEXT "Schnittstelle" x:-1.45cm y:-1.23cm w:l h:c
ENDIF
PEN color:white
FILL color:(color_red)
RECTANGLE x:1.2cm y:-1.35cm w:0.2cm h:0.2cm
LINE x1:1.2cm y1:-1.35cm x2:1.4cm y2:-1.15cm w:0.2cm h:0.2cm
LINE x1:1.2cm y1:-1.15cm x2:1.4cm y2:-1.35cm w:0.2cm h:0.2cm
FILL color:(color_blue)
RECTANGLE x:0.9cm y:-1.35cm w:0.2cm h:0.2cm
RECTANGLE x:0.6cm y:-1.35cm w:0.2cm h:0.2cm
FONT color:(col)
IF (sp = "German")
ATTR "Bezeichnung" y:1.6cm w:c:3.5cm h:t
ELSE
ATTR "Name" y:1.6cm w:c:3.5cm h:t
ENDIF
IF ( token(ext, 1, "@") != " " )
FONT "Wingdings" h:18.0pt color:(col)
TEXT "4" x:1.52cm y:-1.47cm w:r h:b
HOTSPOT "External documentation" x:1.0cm y:-2.2cm w:0.5cm h:0.6cm
ELSE
IF ( refDoc != " " )
FONT "Wingdings" h:18.0pt color:(col)
TEXT "4" x:1.52cm y:-1.47cm w:r h:b
HOTSPOT "Referenced documents" x:1.0cm y:-2.2cm w:0.5cm h:0.6cm
ENDIF
ENDIF
ENDIF
```

```

AVAL oF:"Open questions"
IF ( LEN(replall(replall((oF)," ",""),"
",""))>0 )
  FONT "Arial" h:10.0pt bold color:(color_red)
  TEXT "?" x:1.57cm y:-1.55cm
ENDIF
IF (token(str_bitmap, 1, "@") != "")
  SET cms_width:2.94cm
  SET cms_height:1.94cm
  SET str_bitmap:(token(str_bitmap, 1, "@"))
  BITMAPINFO (str_bitmap) # get the bitmap size
  STRETCH off
  IF (bmpwidth / CMS cms_width < bmpheight / CMS cms_height)
    # use maximum height, space left and right
    SET w:(cms_height * (bmpwidth / bmpheight))
    BITMAP (str_bitmap) x:((0cm - w) / 2) y:((0cm - cms_height) / 2) w:(w)
h:(cms_height)
  ELSE
    # use maximum width, space at top and bottom
    SET h:(cms_width * (bmpheight / bmpwidth))
    BITMAP (str_bitmap) x:((0.0cm - cms_width) / 2) y:((0.0cm - h) / 2)
w:(cms_width) h:(h)
  ENDIF
ENDIF
ENDIF

```

1.1.27 Class "Service"

ADONIS BPMS BP Library 3.9:

```

GRAPHREP
SHADOW off
AVAL sp:"Language"
IF (sp = "System")
  IF (_uilang = "en")
    SET sp:"English"
  ELSE
    SET sp:"German"
  ENDIF
ENDIF
AVAL col:"fontcolor"
AVAL str_bitmap:"Screenshot"
AVAL ext:"External documentation"
AVAL refDoc:"Referenced documents"
AVAL refSysMode:"Referenced IT system model"
AVAL set-default:"no" mono:"Monochrome view"
IF (mono = "yes")
  SET color_fill:(rgbval("black"))
  SET color_red:(rgbval("black"))
  SET color_blue:(rgbval("black"))
ELSE
  SET color_fill:(rgbval("$00c800"))
  SET color_red:(rgbval("red"))
  SET color_blue:(rgbval("blue"))
ENDIF
FILL color:(color_fill)
PEN w:0.05cm color:(color_fill)
IF (mono = "no")
  # start - smooth shaded colors
  CLIP_ROUNDRECT x:-1.5cm y:-1.5cm w:3.0cm h:3.0cm rx:0.2cm ry:0.2cm

```

Part IV

```
GRADIANT_RECT x:-1.5cm y:-1.5cm w:3.0cm h:3.0cm style:downdiag
    color1:$40ff40 color2:(color_fill)
#PEN w:0.05cm
FILL style:null
CLIP_OFF
# end - smooth shaded colors
ENDIF
ROUNDRECT x:-1.5cm y:-1.5cm w:3.0cm h:3.0cm rx:0.2cm ry:0.2cm
FILL color:white
RECTANGLE x:-1.5cm y:-1.0cm w:3.0cm h:2.0cm
PEN w:0.05cm color:black
# gear wheel - start
SET mX:0.51cm
SET mY:-1.53cm
STRETCH off
PEN color:darkgray
FONT "Wingdings" h:18pt color:darkgray bold
FILL color:white
TEXT "" x:(mX) y:(mY) bold
ELLIPSE x:(mX + 0.26cm) y:(mY + 0.33cm) rx:0.05cm ry:0.05cm
FONT "Wingdings" h:18pt color:$474747 bold
TEXT "" x:(mX + 0.4cm) y:(mY - 0.06cm)
FONT
ELLIPSE x:(mX + 0.66cm) y:(mY + 0.26cm) rx:0.05cm ry:0.05cm
PEN
STRETCH on
# gear wheel - end
IF (refSysMode != "")
    FONT "Wingdings" h:15pt color:$474747 bold
    ATTR "Referenced IT system model" text:"D" x:1.25cm y:1.3cm h:c w:c
ENDIF
FONT color:(col)
IF (sp = "German")
    ATTR "Bezeichnung" y:1.6cm w:c:3.5cm h:t
ELSE
    ATTR "Name" y:1.6cm w:c:3.5cm h:t
ENDIF
IF ( token(ext, 1, "@") != "" )
    FONT "Wingdings" h:18.0pt color:(col)
    TEXT "4" x:1.52cm y:-1.47cm w:r h:b
    HOTSPOT "External documentation" x:1.0cm y:-2.2cm w:0.5cm h:0.6cm
ELSE
    IF ( refDoc != "" )
        FONT "Wingdings" h:18.0pt color:(col)
        TEXT "4" x:1.52cm y:-1.47cm w:r h:b
        HOTSPOT "Referenced documents" x:1.0cm y:-2.2cm w:0.5cm h:0.6cm
    ENDIF
ENDIF
ENDIF
AVAL oF:"Open questions"
IF ( LEN(replall(replall((oF)," ",""),"
",""))>0 )
    FONT "Arial" h:10.0pt bold color:(color_red)
    TEXT "?" x:1.57cm y:-1.55cm
ENDIF
IF (token(str_bitmap, 1, "@") != "")
    SET cms_width:2.94cm
    SET cms_height:1.94cm
    SET str_bitmap:(token(str_bitmap, 1, "@"))
    BITMAPINFO (str_bitmap) # get the bitmap size
    STRETCH off
    IF (bmpwidth / CMS cms_width < bmpheight / CMS cms_height)
```

```

    # use maximum height, space left and right
    SET w:(cms_height * (bmpwidth / bmpheight))
    BITMAP (str_bitmap) x:((0cm - w) / 2) y:((0cm - cms_height) / 2) w:(w)
h:(cms_height)
ELSE
    # use maximum width, space at top and bottom
    SET h:(cms_width * (bmpheight / bmpwidth))
    BITMAP (str_bitmap) x:((0.0cm - cms_width) / 2) y:((0.0cm - h) / 2)
w:(cms_width) h:(h)
ENDIF
ENDIF

```

1.1.28 Class "Performance"

ADONIS BPMS BP Library 3.9:

```

GRAPHREP
SHADOW off
AVAL refElem:"Referenced element"
AVAL set-format:"%t" set-default:"" refModeltype:"Referenced element"
AVAL sn:"refObjectNameEN"
AVAL sp:"Language"
IF (sp = "System")
    IF (_uilang = "en")
        SET sp:"English"
    ELSE
        SET sp:"German"
    ENDIF
ENDIF
AVAL col:"fontcolor"
AVAL ext:"External documentation"
AVAL refDoc:"Referenced documents"
FONT color:(col)
AVAL set-default:"no" mono:"Monochrome view"
IF (mono = "yes")
    SET bMono:1
ELSE
    SET bMono:0
ENDIF
PEN w:0.03cm
IF (bMono)
    SET color_fill:(rgbval("white"))
    SET color_red:(rgbval("black"))
ELSE
    SET color_red:(rgbval("red"))
    IF (refModeltype = "Product model")
        SET color_fill:(rgbval("$ffd3a8"))
        SET color_fill2:(rgbval("$ee7700"))
        SET color_pen:(rgbval("$ee7700"))
    ELSIF (refModeltype = "IT system model")
        SET color_fill:(rgbval("$a6ffa6"))
        SET color_fill2:(rgbval("$006800"))
        SET color_pen:(rgbval("$006800"))
    ELSIF (refModeltype = "Document model")
        SET color_fill:(rgbval("$fff9c1"))
        SET color_fill2:(rgbval("$f9bb00"))
        SET color_pen:(rgbval("$f9bb00"))
    ELSE
        SET color_fill:(rgbval("$e7e7e7"))
    ENDIF
ENDIF

```

Part IV

```
        SET color_fill2:(rgbval("$949494"))
        SET color_pen:(rgbval("$949494"))
    ENDIF
ENDIF
IF (NOT bMono)
    # start - smooth shaded colors
    CLIP_POLY 10 x1:-1.63cm y1:0.0cm
                x2:-1.23cm y2:-0.7cm
                x3:-1.23cm y3:-0.6cm
                x4:1.23cm y4:-0.6cm
                x5:1.23cm y5:-0.7cm
                x6:1.63cm y6:0.0cm
                x7:1.23cm y7:0.7cm
                x8:1.23cm y8:0.6cm
                x9:-1.23cm y9:0.6cm
                x10:-1.23cm y10:0.7cm
    GRADIENT_RECT x:-1.63cm y:-.7cm w:3.26cm h:1.4cm style:downdiag
                  color1:(color_fill) color2:(color_fill2)
    PEN w:0.08cm color:(color_pen) join:miter
    FILL style:null
    CLIP_OFF
    # end - smooth shaded colors
ELSE
    PEN w:0.05cm
    FILL color:(color_fill)
ENDIF
POLYGON 10 x1:-1.63cm y1:0.0cm
          x2:-1.23cm y2:-0.7cm
          x3:-1.23cm y3:-0.6cm
          x4:1.23cm y4:-0.6cm
          x5:1.23cm y5:-0.7cm
          x6:1.63cm y6:0.0cm
          x7:1.23cm y7:0.7cm
          x8:1.23cm y8:0.6cm
          x9:-1.23cm y9:0.6cm
          x10:-1.23cm y10:0.7cm
FONT h:10pt
IF (refElem = "")
    IF (sp = "English")
        ATTR "Name" w:c:2.90cm h:c:1.2cm line-break:words line-height:10pt
    ELSE
        ATTR "Bezeichnung" w:c:2.90cm h:c:1.2cm line-break:words line-height:10pt
    ENDIF
ELSE
    IF (sp = "English")
        ATTR "Referenced element" format:"%o" w:c:2.90cm h:c:1.2cm line-break:words
line-height:10pt
    ELSE
        ATTR "Referenced element" text:(sn) format:"%o" w:c:2.90cm h:c:1.2cm line-
break:words line-height:10pt
    ENDIF
ENDIF
IF ( token(ext, 1, "@") != "" )
    FONT "Wingdings" h:18.0pt color:(col)
    TEXT "4" x:1.30cm y:-0.6cm w:r h:b
    HOTSPOT "External documentation" x:0.75cm y:-1.3cm w:0.5cm h:0.6cm
ELSE
    IF ( refDoc != "" )
        FONT "Wingdings" h:18.0pt color:(col)
        TEXT "4" x:1.30cm y:-0.6cm w:r h:b
        HOTSPOT "Referenced documents" x:0.75cm y:-1.3cm w:0.5cm h:0.6cm
    
```

```

ENDIF
ENDIF
AVAL oF:"Open questions"
IF ( LEN(replall(replall((oF), " ", ""), "
", ""))>0 )
    FONT "Arial" h:10.0pt bold color:(color_red)
    TEXT "?" x:1.35cm y:-1.0cm
ENDIF

```

1.1.29 Class "Infrastructure element"

ADONIS BPMS BP Library 3.9:

```

GRAPHREP
SHADOW off
AVAL sp:"Language"
IF (sp = "System")
    IF (_uilang = "en")
        SET sp:"English"
    ELSE
        SET sp:"German"
    ENDIF
ENDIF
AVAL col:"fontcolor"
AVAL str_bitmap:"Screenshot"
AVAL ext:"External documentation"
AVAL refDoc:"Referenced documents"
AVAL refSysMode:"Referenced IT system model"
AVAL set-default:"no" mono:"Monochrome view"
IF (mono = "yes")
    SET color_fill:(rgbval("black"))
    SET color_red:(rgbval("black"))
    SET color_blue:(rgbval("black"))
ELSE
    SET color_fill:(rgbval("$006200"))
    SET color_red:(rgbval("red"))
    SET color_blue:(rgbval("blue"))
ENDIF
FILL color:(color_fill)
PEN w:0.05cm color:(color_fill)
IF (mono = "no")
    # start - smooth shaded colors
    CLIP_ROUNDRECT x:-1.5cm y:-1.5cm w:3.0cm h:3.0cm rx:0.2cm ry:0.2cm
    GRADIENT_RECT x:-1.5cm y:-1.5cm w:3.0cm h:3.0cm style:downdiag
        color1:$00c800 color2:$003c00
    #PEN w:0.05cm
    FILL style:null
    CLIP_OFF
    # end - smooth shaded colors
ENDIF
ROUNDRECT x:-1.5cm y:-1.5cm w:3.0cm h:3.0cm rx:0.2cm ry:0.2cm
FILL color:white
RECTANGLE x:-1.5cm y:-1.0cm w:3.0cm h:2.0cm
PEN w:0.05cm color:black
FONT "Wingdings" h:15pt color:white
TEXT ":" x:1.19cm y:-1.17cm h:c w:c
IF (refSysMode != "")
    FONT "Wingdings" h:15pt color:white
    ATTR "Referenced IT system model" text:"B" x:1.25cm y:1.3cm h:c w:c

```

Part IV

```
ENDIF
FONT color:(col)
IF (sp = "English")
  ATTR "Name" y:1.6cm w:c:3.5cm h:t
ELSE
  ATTR "Bezeichnung" y:1.6cm w:c:3.5cm h:t
ENDIF
IF ( token(ext, 1, "@") != "" )
  FONT "Wingdings" h:18.0pt color:(col)
  TEXT "4" x:1.52cm y:-1.47cm w:r h:b
  HOTSPOT "External documentation" x:1.0cm y:-2.2cm w:0.5cm h:0.6cm
ELSE
  IF ( refDoc != "" )
    FONT "Wingdings" h:18.0pt color:(col)
    TEXT "4" x:1.52cm y:-1.47cm w:r h:b
    HOTSPOT "Referenced documents" x:1.0cm y:-2.2cm w:0.5cm h:0.6cm
  ENDIF
ENDIF
AVAL oF:"Open questions"
IF ( LEN(replall(replall((oF)," ",""),"
",""))>0 )
  FONT "Arial" h:10.0pt bold color:(color_red)
  TEXT "?" x:1.57cm y:-1.55cm
ENDIF
IF (token(str_bitmap, 1, "@") != "")
  SET cms_width:2.94cm
  SET cms_height:1.94cm
  SET str_bitmap:(token(str_bitmap, 1, "@"))
  BITMAPINFO (str_bitmap) # get the bitmap size
  STRETCH off
  IF (bmpwidth / CMS cms_width < bmpheight / CMS cms_height)
    # use maximum height, space left and right
    SET w:(cms_height * (bmpwidth / bmpheight))
    BITMAP (str_bitmap) x:((0cm - w) / 2) y:((0cm - cms_height) / 2) w:(w)
h:(cms_height)
  ELSE
    # use maximum width, space at top and bottom
    SET h:(cms_width * (bmpheight / bmpwidth))
    BITMAP (str_bitmap) x:((0.0cm - cms_width) / 2) y:((0.0cm - h) / 2)
w:(cms_width) h:(h)
  ENDIF
ENDIF
ENDIF
```

1.1.30 Class "Cross-reference"

ADONIS BPMS BP Library 3.9:

```
GRAPHREP
SHADOW off
AVAL set-default:"no" mono:"Monochrome view"
AVAL set-format:"%t" set-default:"" refModeltype:"Cross-reference"
AVAL refMod:"Cross-reference"
AVAL sTypeCrossReference:"Type of Cross-reference"
IF (sTypeCrossReference = "Incoming Cross-reference")
  SET col_color1:("$feece3")
  SET col_color2:("$d71c15")
ELSIF (sTypeCrossReference = "Outgoing Cross-reference")
  SET col_color1:("$d71c15")
  SET col_color2:("$feece3")
```



```

ELSE
  SET col_color1:("$dd4b4b")
  SET col_color2:("$a40000")
ENDIF
AVAL sp:"Language"
IF (sp = "System")
  IF (_uilang = "en")
    SET sp:"English"
  ELSE
    SET sp:"German"
  ENDIF
ENDIF
IF (sp = "System")
  IF (_uilang = "en")
    SET sp:"English"
  ELSE
    SET sp:"German"
  ENDIF
ENDIF
AVAL subprocess:"Subprocessname"
IF (mono = "yes")
  FILL color:white
  PEN w:0.08cm
ELSE
  # start - smooth shaded colors
  CLIP_POLY 5 x1:-2cm y1:-.5cm x2:1.0cm y2:-.5cm x3:1.3cm y3:0cm x4:1.0cm y4:.5cm
x5:-2cm y5:.5cm
  GRADIENT_RECT x:-2.0cm y:-.5cm w:3.3cm h:1.0cm style:downdiag
    color1:(col_color1) color2:(col_color2)
  PEN w:0.08cm color:$a40000 join:miter
  FILL style:null
  CLIP_OFF
  # end - smooth shaded colors
ENDIF
POLYGON 5 x1:-2cm y1:-.5cm x2:1.0cm y2:-.5cm x3:1.3cm y3:0cm x4:1.0cm y4:.5cm
x5:-2cm y5:.5cm
IF (refMod != "")
  # visualize icon of target model type
  IF (refModeltype = "Product model")
    SET str_bitmap:("db:\\prod.bmp")
  ELSIF (refModeltype = "Company map")
    SET str_bitmap:("db:\\compmap.bmp")
  ELSIF (refModeltype = "Business process model")
    SET str_bitmap:("db:\\gp.bmp")
  ELSIF (refModeltype = "IT system model")
    SET str_bitmap:("db:\\itsys.bmp")
  ELSIF (refModeltype = "Use case diagram")
    SET str_bitmap:("db:\\uml_use.bmp")
  ELSIF (refModeltype = "Document model")
    SET str_bitmap:("db:\\doc_mod.bmp")
  ELSIF (refModeltype = "Working environment model")
    SET str_bitmap:("db:\\au.bmp")
  ELSE
    # unknown target model type
    SET str_bitmap:("db:\\gp.bmp")
  ENDIF
  SET cms_width:0.35cm
  SET cms_height:0.35cm
  BITMAPINFO (str_bitmap) # get the bitmap size
  STRETCH off
  # use maximum width, space at top and bottom

```

Part IV

```
SET h:(cms_width * (bmpheight / bmpwidth))
IF (sTypeCrossReference = "Outgoing Cross-reference")
  BITMAP (str_bitmap) x:((2.2cm - cms_width) / 2) y:((1.65cm - h) / 2)
w:(cms_width) h:(h)
ELSE
  BITMAP (str_bitmap) x:(-3.7cm - cms_width) / 2) y:((1.65cm - h) / 2)
w:(cms_width) h:(h)
ENDIF
IF (sp = "German")
  IF (sTypeCrossReference = "Outgoing Cross-reference")
    ATTR "Cross-reference" text:(subprocess) x:((2.2cm - cms_width) / 2) y:0.65cm
w:r:3cm h:t
  ELSE
    ATTR "Cross-reference" text:(subprocess) x:-1.6cm y:0.65cm w:l:3cm h:t
  ENDIF
ELSE
  IF (sTypeCrossReference = "Outgoing Cross-reference")
    ATTR "Cross-reference" format:"%m" x:((2.2cm - cms_width) / 2) y:0.65cm
w:r:3cm h:t
  ELSE
    ATTR "Cross-reference" format:"%m" x:-1.6cm y:0.65cm w:l:3cm h:t
  ENDIF
ENDIF
ELSE
  IF (sp = "German")
    ATTR "Bezeichnung" x:-0.4cm y:0.65cm w:c:3cm h:t
  ELSE
    ATTR "Name" x:-0.4cm y:0.65cm w:c:3cm h:t
  ENDIF
ENDIF
ENDIF
```

1.1.31 Class "Organizational unit"

ADONIS BPMS WE Library 3.9:

```
GRAPHREP
SHADOW off
AVAL sp:"Language"
IF (sp = "System")
  IF (_uilang = "de")
    SET sp:"German"
  ELSE
    SET sp:"English"
  ENDIF
ENDIF
AVAL sub:"Model reference"
AVAL col:"fontcolor"
AVAL sn:"Submodelname"
AVAL set-default:"Standard" t:"Type"
AVAL set-default:"no" s:"Functional unit"
AVAL set-default:"" fbd:"Name"
AVAL set-default:"" r:"Referenced organigram"
AVAL set-default:"Variant without positions" v:"Organigram variant"
AVAL set-default:"no" mono:"Monochrome view"
IF (mono = "yes")
  SET bMono:1
ELSE
  SET bMono:0
ENDIF
ENDIF
```

```

IF (bMono)
  SET color_lightsteelblue:(rgbval("lightgray"))
  SET color_steelblue:(rgbval("mediumgray"))
  SET color_lightsteelblue_pen:(rgbval("lightgray"))
  SET color_aliceblue:(rgbval("whitesmoke"))
  SET color_aliceblue_pen:(rgbval("whitesmoke"))
  SET color_darkeraliceblue:(rgbval("lightgray"))
  SET color_blue_fill:(rgbval(100,100,100))
  SET color_red:(rgbval(100,100,100))
  SET color_blue:(rgbval(100,100,100))
  SET col:(rgbval("black"))
ELSE
  SET color_lightsteelblue:(rgbval("lightsteelblue"))
  SET color_steelblue:(rgbval("steelblue"))
  SET color_lightsteelblue_pen:(rgbval("lightsteelblue"))
  SET color_aliceblue:(rgbval("aliceblue"))
  SET color_aliceblue_pen:(rgbval("aliceblue"))
  SET color_darkeraliceblue:(rgbval(195,226,255))
  SET color_red:(rgbval("red"))
  SET color_blue:(rgbval("blue"))
  SET color_blue_fill:(rgbval("mediumblue"))
ENDIF
IF (sp = "English")
  SET sCheckAssignment:("Check assignment!\n(Attribut 'Type')")
ELSE
  SET sCheckAssignment:("Zuordnung überprüfen!\n(Attribute 'Type')")
ENDIF
IF (t = "Standard")
PEN w:0.025cm
FONT color:(col)
  IF (bMono)
FILL color:whitesmoke
  ELSE
    SHADOW off
    GRADIENT_RECT x:-1.2cm y:-.75cm w:2.4cm h:1.5cm style:downdiag color1:white
color2:lightgray
    FILL style:null
    PEN w:0.08cm color:lightgray join:miter
  ENDIF
RECTANGLE x:-1.2cm y:-.75cm w:2.4cm h:1.5cm
PEN w:0.05cm
FILL color:black
RECTANGLE x:-1.1cm y:-.65cm w:2.2cm h:0.06cm
IF (sub = "")
  IF (sp = "English")
    ATTR "Name" y:.9cm w:c:2.8cm h:t
  ELSE
    ATTR "Bezeichnung" y:.9cm w:c:2.8cm h:t
  ENDIF
ELSE
  IF (sp = "English")
    ATTR "Model reference" format:"%m" y:.9cm w:c:2.8cm h:t
  ELSE
    ATTR "Model reference" text:(sn) y:.9cm w:c:2.8cm h:t
  ENDIF
ENDIF
ENDIF
AVAL i:"Order"
IF (i > "0")
  FONT "Arial" h:10.0pt bold color:black

```

Part IV

```
ATTR "Order" x:1.1cm y:.6cm w:r:1cm h:b
ENDIF
ELSE
  FONT "Arial" h:8.0pt
  IF (s = "no")
    IF (t = "Company")
      PEN color:black
      IF (bMono)
        FILL color:(color_blue_fill)
      ELSE
        SHADOW off
        CLIP_ROUNDRECT x:-2.25cm y:-0.9cm w:4.5cm h:1.8cm rx:0.27cm ry:0.27cm
        GRADIENT_RECT x:-2.25cm y:-0.9cm w:4.5cm h:1.8cm style:downdiag
color1:lightskyblue color2:mediumblue
        FILL style:null
        PEN w:0.08cm color:(color_blue_fill) join:miter
        CLIP_OFF
      ENDIF
      ROUNDRECT x:-2.25cm y:-0.9cm w:4.5cm h:1.8cm rx:0.3cm ry:0.3cm
      FONT color:white bold
      IF (sp = "English")
        ATTR "Name" x:0.00cm y:0.00cm w:c:4.3cm h:c:1.0cm line-break:rigorous
      ELSE
        ATTR "Bezeichnung" x:0.00cm y:0.00cm w:c:4.3cm h:c:1.0cm line-
break:rigorous
      ENDIF
    ELSIF (t = "Division")
      PEN color:black
      IF (bMono)
        FILL color:(color_lightsteelblue)
      ELSE
        SHADOW off
        CLIP_RECT x:-2.25cm y:-0.9cm w:4.5cm h:1.35cm rx:0.3cm ry:0.3cm
        GRADIENT_RECT x:-2.25cm y:-0.9cm w:4.5cm h:1.8cm style:downdiag
color1:white color2:steelblue
        FILL style:null
        PEN w:0.08cm color:(color_steelblue) join:miter
        CLIP_OFF
      ENDIF
      COMPOUND 4
      #UntenRechts
      CURVE "t" fx:(2.25+.0*sin(t)) fy:(.9+.0*cos(t)) from:0 to:1.57
      #ObenRechts
      CURVE "t" fx:(2.25+.0*sin(t)) fy:(-.9+.0*cos(t)) from:1.57 to:3.14
      #OpenLinks
      CURVE "t" fx:(-1.85+.4*sin(t)) fy:(-0.5+.4*cos(t)) from:3.14 to:4.71
      #UntenLinks
      CURVE "t" fx:(-2.25+.0*sin(t)) fy:(.9+.0*cos(t)) from:4.71 to:6.28
      PEN color:(color_steelblue) w:0.08cm
      LINE x1:-2.25cm y1:0.45cm x2:2.25cm y2:0.45cm
      IF (NOT bMono) {
        FILL color:white
        RECTANGLE x:-2.25cm y:0.45cm w:4.5cm h:0.45cm
      }
      PEN
      FONT bold
      IF (sp = "English")
        ATTR "Name" x:0.00cm y:-.15cm w:c:4.3cm h:c:.8cm line-break:rigorous
      ELSE
        ATTR "Bezeichnung" x:0.00cm y:-.15cm w:c:4.3cm h:c:.8cm line-break:rigorous
      ENDIF
    ENDIF
  ENDIF
ENDIF
```

```

FONT
ATTR "Manager" x:0.00cm y:.70cm w:c:4.3cm h:c:.8cm line-break:rigorous
ELSIF (t = "Department")
  PEN color:black
  IF (bMono)
    FILL color:(color_aliceblue)
  ELSE
    SHADOW off
    GRADIENT_RECT x:-2.25cm y:-0.9cm w:4.5cm h:1.35cm style:downdiag
color1:(color_aliceblue) color2:(color_darkeraliceblue)
    FILL style:null
    PEN w:0.08cm color:(color_darkeraliceblue) join:miter
    CLIP_OFF
  ENDIF
  RECTANGLE x:-2.25cm y:-.9cm w:4.5cm h:1.8cm
  PEN color:(color_darkeraliceblue) w:0.08cm
  LINE x1:-2.25cm y1:0.45cm x2:2.25cm y2:0.45cm
  IF (NOT bMono) {
    FILL color:white
    RECTANGLE x:-2.25cm y:0.45cm w:4.5cm h:0.45cm
  }
  PEN
  FONT bold
  IF (sp = "English")
    ATTR "Name" x:0.00cm y:-.15cm w:c:4.3cm h:c:.8cm line-break:rigorous
  ELSE
    ATTR "Bezeichnung" x:0.00cm y:-.15cm w:c:4.3cm h:c:.8cm line-break:rigorous
  ENDIF
  FONT
  ATTR "Manager" x:0.00cm y:.70cm w:c:4.3cm h:c:.8cm line-break:rigorous
ELSE
  PEN color:black
  IF (bMono)
    FILL color:white
  ELSE
    SHADOW off
    GRADIENT_RECT x:-2.25cm y:-0.9cm w:4.5cm h:1.8cm style:downdiag
color1:white color2:lightgray
    FILL style:null
    PEN w:0.08cm color:lightgray join:miter
    CLIP_OFF
  ENDIF
  RECTANGLE x:-2.25cm y:-0.90cm w:4.5cm h:1.8cm
  FONT color:(color_red) bold
  TEXT (sCheckAssignment) w:c:4.3cm h:c:1.1cm
  FONT
  ENDIF
ELSE
  IF (t = "")
    PEN color:black
    IF (bMono)
      FILL color:white
    ELSE
      SHADOW off
      GRADIENT_RECT x:-2.25cm y:-0.9cm w:4.5cm h:1.35cm style:downdiag
color1:white color2:lightgray
      FILL style:null
      PEN w:0.08cm color:lightgray join:miter
      CLIP_OFF
    ENDIF
  ENDIF
COMPOUND 4

```

Part IV

```
#UntenRechts
  CURVE "t" fx:(1.85+.4*sin(t)) fy:(0.5+.4*cos(t)) from:0 to:1.57
#ObenRechts
  CURVE "t" fx:(2.25+.0*sin(t)) fy:(-.9+.0*cos(t)) from:1.57 to:3.14
#OpenLinks
  CURVE "t" fx:(-1.85+.4*sin(t)) fy:(-0.5+.4*cos(t)) from:3.14 to:4.71
#UntenLinks
  CURVE "t" fx:(-2.25+.0*sin(t)) fy:(.9+.0*cos(t)) from:4.71 to:6.28
  PEN color:gray w:0.08cm
  LINE x1:-2.25cm y1:0.45cm x2:2.25cm y2:0.45cm
  IF (NOT bMono) {
    FILL color:white
    RECTANGLE x:-2.25cm y:0.45cm w:4.5cm h:0.45cm
  }
  PEN
  FONT bold
  IF (sp = "English")
    ATTR "Name" x:0.00cm y:-.15cm w:c:4.3cm h:c:.8cm line-break:rigorous
  ELSE
    ATTR "Bezeichnung" x:0.00cm y:-.15cm w:c:4.3cm h:c:.8cm line-break:rigorous
  ENDIF
  FONT
  ATTR "Manager" x:0.00cm y:.70cm w:c:4.3cm h:c:.8cm line-break:rigorous
ELSE
  PEN color:black
  IF (bMono)
    FILL color:white
  ELSE
    SHADOW off
    GRADIENT_RECT x:-2.25cm y:-0.9cm w:4.5cm h:1.8cm style:downdiag
color1:white color2:lightgray
    FILL style:null
    PEN w:0.08cm color:lightgray join:miter
    CLIP_OFF
  ENDIF
  RECTANGLE x:-2.25cm y:-0.90cm w:4.5cm h:1.8cm
  PEN w:0.05cm
  FONT color:(color_red) bold
  TEXT (sCheckAssignment) w:c:4.3cm h:c:1.1cm
  FONT
ENDIF
ENDIF
IF (r <> "")
  FONT "wingdings" h:11pt
  TEXT "Ä" x:1.9cm y:-.80cm
  HOTSPOT "Referenced organigram" x:1.90cm y:-.80cm w:0.3cm h:0.3cm
  FONT
ENDIF
IF (v = "Variant with indicators")
  PEN color:darkgray
  FILL color:white
  RECTANGLE x:-2.25cm y:1.1cm w:4.5cm h:1.59cm
  LINE x1:-2.25cm y1:1.63cm x2:2.2cm y2:1.63cm
  LINE x1:-2.25cm y1:2.16cm x2:2.2cm y2:2.16cm
  LINE x1:-0.75cm y1:1.1cm x2:-0.75cm y2:2.69cm
  LINE x1:0.75cm y1:1.1cm x2:0.75cm y2:2.69cm
  PEN
  FONT bold h:7pt
  TEXT "Org. Index" x:-2.15cm y:1.895cm w:l h:c
  TEXT "Aggr. Index" x:-2.15cm y:2.425cm w:l h:c
  TEXT "Abs." x:0.00cm y:1.365cm w:c h:c
```

```

TEXT "Rel." x:1.50cm y:1.365cm w:c h:c
FONT color:(color_blue) h:7pt
ATTR "Planned number of positions (Org.- absolute)" x:-0.10cm y:1.895cm w:r h:c
FONT h:7pt
TEXT "/" x:0.00cm y:1.895cm w:c h:c
FONT color:(color_red) h:7pt
ATTR "Number of open positions (Org.- absolute)" x:0.10cm y:1.895cm w:l h:c
FONT color:(color_blue) h:7pt
ATTR "Planned number of positions (Org.- relative)" x:1.40cm y:1.895cm w:r h:c
FONT h:7pt
TEXT "/" x:1.50cm y:1.895cm w:c h:c
FONT color:(color_red) h:7pt
ATTR "Number of open positions (Org.- relative)" x:1.60cm y:1.895cm w:l h:c
FONT h:7pt
FONT color:(color_blue) h:7pt
ATTR "Planned number of positions (Agg.- absolute)" x:-0.10cm y:2.425cm w:r h:c
FONT h:7pt
TEXT "/" x:0.00cm y:2.425cm w:c h:c
FONT color:(color_red) h:7pt
ATTR "Number of open positions (Agg.- absolute)" x:0.10cm y:2.425cm w:l h:c
FONT h:7pt
FONT color:(color_blue) h:7pt
ATTR "Planned number of positions (Agg.- relative)" x:1.40cm y:2.425cm w:r h:c
FONT h:7pt
TEXT "/" x:1.50cm y:2.425cm w:c h:c
FONT color:(color_red) h:7pt
ATTR "Number of open positions (Agg.- relative)" x:1.60cm y:2.425cm w:l h:c
ENDIF
ENDIF

```

1.1.32 Class "Performer"

ADONIS BPMS WE Library 3.9:

```

GRAPHREP
SHADOW off
AVAL sp:"Language"
IF (sp = "System")
  IF (_uilang = "de")
    SET sp:"German"
  ELSE
    SET sp:"English"
  ENDIF
ENDIF
AVAL col:"fontcolor"
AVAL set-default:"no" mono:"Monochrome view"
IF (mono = "yes")
  SET bMono:1
ELSE
  SET bMono:0
ENDIF
IF (bMono)
  SET color_peru:(rgbval("white"))
  SET col:(rgbval("black"))
ELSE
  SET color_peru:(rgbval("peru"))
ENDIF
PEN w:0.025cm
IF (bMono)

```

Part IV

```
FILL color:(color_peru)
ELSE
  GRADIENT_RECT x:-1.1cm y:-.50cm w:2.2cm h:.15cm style:downdiag color1:$e8c5a2
  color2:(color_peru)
  GRADIENT_RECT x:-1.0cm y:-.35cm w:.12cm h:1.0cm style:downdiag color1:$e8c5a2
  color2:(color_peru)
  GRADIENT_RECT x:0.88cm y:-.35cm w:.12cm h:1.0cm style:downdiag color1:$e8c5a2
  color2:(color_peru)
  GRADIENT_RECT x:.3cm y:-.35cm w:.7cm h:.7cm style:downdiag color1:$e8c5a2
  color2:(color_peru)
  FILL style:null
  CLIP_OFF
ENDIF
RECTANGLE x:-1.1cm y:-.50cm w:2.2cm h:.15cm
RECTANGLE x:-1.0cm y:-.35cm w:.12cm h:1.0cm
RECTANGLE x:0.88cm y:.35cm w:.12cm h:.3cm
RECTANGLE x:.3cm y:-.35cm w:.7cm h:.7cm
LINE x1:.3cm x2:1.0cm
FILL color:black
RECTANGLE x:.55cm y:-.21cm w:.2cm h:.03cm
RECTANGLE x:.55cm y:0.15cm w:.2cm h:.03cm
FONT color:(col)
IF (sp = "English")
  ATTR "Name" y:.8cm w:c:2.8cm h:t
ELSE
  ATTR "Bezeichnung" y:.8cm w:c:2.8cm h:t
ENDIF
```

1.1.33 Class "Role"

ADONIS BPMS WE Library 3.9:

```
GRAPHREP
SHADOW off
AVAL sp:"Language"
IF (sp = "System")
  IF (_uilang = "de")
    SET sp:"German"
  ELSE
    SET sp:"English"
  ENDIF
ENDIF
AVAL col:"fontcolor"
AVAL set-default:"no" mono:"Monochrome view"
IF (mono = "yes")
  SET bMono:1
ELSE
  SET bMono:0
ENDIF
IF (bMono)
  SET color_lightskyblue:(rgbval("white"))
  SET col:(rgbval("black"))
  FILL color:(color_lightskyblue)
ELSE
  SET color_lightskyblue:"lightskyblue"
  SHADOW off
  CLIP_ELLIPSE rx:.78cm ry:.68cm
  GRADIENT_RECT x:-.75cm y:-0.75cm w:1.5cm h:1.5cm style:downdiag color1:(rgbval
  (color_lightskyblue, 1.4)) color2:(rgbval (color_lightskyblue, 0.7))
```



```

FILL style:null
PEN w:0.08cm color:(rgbval (color_lightskyblue, 0.7)) join:miter
CLIP_OFF
ENDIF
ELLIPSE rx:.75cm ry:.65cm
FONT color:(col)
IF (sp = "English")
  ATTR "Name" y:.8cm w:c:2.8cm h:t
ELSE
  ATTR "Bezeichnung" y:.8cm w:c:2.8cm h:t
ENDIF
FONT "Arial" h:32pt color:black
TEXT "R" y:.1cm w:c h:c

```

1.1.34 Class "Position"

ADONIS BPMS WE Library 3.9:

```

GRAPHREP
SHADOW off
AVAL set-default:"" k:"Cost center"
AVAL set-default:"no" v:"Vacant"
AVAL set-default:" " i:"Owner"
AVAL set-default:"" p:"Position name"
AVAL set-default:"" r:"Position capacity"
PEN color:darkgray
IF (bMono)
FILL color:white
ELSE
  SET color_lightskyblue:(rgbval("lightskyblue"))
  SHADOW off
  GRADIENT_RECT x:-2.25cm y:-0.40cm w:4.5cm h:.80cm style:downdiag color1:white
  color2:lightgray
  FILL style:null
  PEN w:0.08cm color:darkgray join:miter
  CLIP_OFF
ENDIF
RECTANGLE x:-2.25cm y:-0.40cm w:4.5cm h:.80cm
#IF (k <> "")
# FONT h:8.0pt
# TEXT "Kstl:" x:3.50cm y:.05cm w:r h:t
# ATTR "Cost center" x:3.6cm y:.05cm w:l h:t
# FONT
#ENDIF
#IF (p <> "")
# ATTR "Planstellenbezeichnung" x:1.85cm y:0.7cm w:c:3.0cm h:c:1.3cm line-
break:rigorous
#ENDIF
#IF (r <> "")
# FONT h:8.0pt
# ATTR "Planstellenkapazität" x:-0.1cm y:.05cm w:l h:t
# FONT
#ENDIF
IF (i = "")
  IF (v = "yes")
    FONT h:9.0pt
    TEXT "NN" w:c:4.3cm h:c:.6cm
  ELSE
    FONT h:9.0pt

```

Part IV

```
TEXT "NN" w:c:4.3cm h:c:.6cm
ENDIF
ELSE
IF (v = "yes")
ATTR "Owner" w:c:4.3cm h:c:.6cm
ELSE
ATTR "Owner" w:c:4.3cm h:c:.6cm
ENDIF
ENDIF
ENDIF
```

1.1.35 Class "Resource"

ADONIS BPMS WE Library 3.9:

```
GRAPHREP layer:2
SHADOW off
AVAL set-default:"EDP system" rt:"Type of resource"
AVAL sp:"Language"
IF (sp = "System")
IF (_uilang = "de")
SET sp:"German"
ELSE
SET sp:"English"
ENDIF
ENDIF
AVAL col:"fontcolor"
AVAL set-default:"no" mono:"Monochrome view"
AVAL str_bitmap:"Screenshot"
IF (mono = "yes")
SET bMono:1
ELSE
SET bMono:0
ENDIF
PEN w:0.05cm
IF (bMono)
SET color_lightskyblue:(rgbval("white"))
SET color_navy:(rgbval("black"))
SET color_lightgreen:(rgbval("white"))
SET color_palegreen:(rgbval("white"))
SET color_orangered:(rgbval("white"))
SET color_mistyrose:(rgbval("white"))
SET color_forestgreen:(rgbval("white"))
SET color_lightsteelblue:(rgbval("white"))
SET col:(rgbval("black"))
ELSE
SET color_lightskyblue:(rgbval("lightskyblue"))
SET color_navy:(rgbval("navy"))
SET color_lightgreen:(rgbval("lightgreen"))
SET color_palegreen:(rgbval("palegreen"))
SET color_orangered:(rgbval("orangered"))
SET color_mistyrose:(rgbval("mistyrose"))
SET color_forestgreen:(rgbval("forestgreen"))
SET color_lightsteelblue:(rgbval("lightsteelblue"))
ENDIF
IF (token(str_bitmap, 1, "@") != "")
SET cms_width:2.8cm
SET cms_height:1.94cm
SET str_bitmap:(token(str_bitmap, 1, "@"))
BITMAPINFO (str_bitmap) # get the bitmap size
```

```

STRETCH off
IF (bmpwidth / CMS cms_width < bmpheight / CMS cms_height)
  # use maximum height, space left and right
  SET w:(cms_height * (bmpwidth / bmpheight))
  BITMAP (str_bitmap) x:((0cm - w) / 2) y:((-0.4cm - cms_height) / 2) w:(w)
h:(cms_height)
ELSE
  # use maximum width, space at top and bottom
  SET h:(cms_width * (bmpheight / bmpwidth))
  BITMAP (str_bitmap) x:((0.0cm - cms_width) / 2) y:((0.3cm - h) / 2)
w:(cms_width) h:(h)
ENDIF
ELSE
IF (rt = "EDP system")
  FILL color:lightgray
  IF (NOT bMono)
    # start - smooth shaded colors
    CLIP_RECT x:-.6cm y:-.7cm w:1.2cm h:1.05cm
    GRADIENT_RECT x:-.6cm y:-.7cm w:1.2cm h:1.05cm style:updiag
      color1:white color2:lightgray
    FILL style:null
    PEN w:0.08cm color:$6b6b6b join:miter
    CLIP_OFF
    # end - smooth shaded colors
  ENDIF
  RECTANGLE x:-.6cm y:-.7cm w:1.2cm h:1.05cm
  IF (NOT bMono)
    # start - smooth shaded colors
    CLIP_RECT x:-.7cm y:.35cm w:1.4cm h:.35cm
    GRADIENT_RECT x:-.7cm y:.35cm w:1.4cm h:.35cm style:updiag
      color1:white color2:lightgray
    PEN w:0.08cm color:$6b6b6b join:miter
    FILL style:null
    CLIP_OFF
    # end - smooth shaded colors
  ENDIF
  RECTANGLE x:-.7cm y:.35cm w:1.4cm h:.35cm
  FILL color:(color_lightskyblue)
  # start - smooth shaded colors
  CLIP_RECT x:-.45cm y:-.55cm w:.9cm h:.75cm
  GRADIENT_RECT x:-.45cm y:-.55cm w:.9cm h:.75cm style:updiag
    color1:white color2:(color_lightskyblue)
  PEN w:0.05cm
  FILL style:null
  CLIP_OFF
  # end - smooth shaded colors
  RECTANGLE x:-.45cm y:-.55cm w:.9cm h:.75cm
  FILL color:(color_navy)
  RECTANGLE x:-.3cm y:-.45cm w:.4cm h:.05cm
  FILL color:white
  RECTANGLE x:-.3cm y:-.4cm w:.4cm h:.2cm
  FILL color:(color_navy)
  RECTANGLE x:-.1cm y:-.15cm w:.4cm h:.05cm
  FILL color:white
  RECTANGLE x:-.1cm y:-.1cm w:.4cm h:.2cm
  FILL color:(color_lightgreen)
  RECTANGLE x:-.57cm y:.48cm w:.09cm h:.09cm
  FILL color:black
  RECTANGLE x:.15cm y:.48cm w:.45cm h:.03cm
ELSIF (rt = "Communication system")
  FILL color:slategray

```

Part IV

```
IF (NOT bMono)
  # start - smooth shaded colors
  CLIP_RECT x:-.275cm y:-.7cm w:.55cm h:1.4cm
  GRADIENT_RECT x:-.275cm y:-.7cm w:.55cm h:1.4cm style:updiag
    color1:white color2:gray
  PEN w:0.08cm color:$484848 join:miter
  FILL style:null
  CLIP_OFF
  # end - smooth shaded colors
ENDIF
RECTANGLE x:-.275cm y:-.7cm w:.55cm h:1.4cm
FILL color:black
RECTANGLE x:.14cm y:-1cm w:.05cm h:.3cm
  PEN w:0.05cm
  FILL color:(color_palegreen)
RECTANGLE x:-.225cm y:-.55cm w:.45cm h:.3cm
FILL color:black
RECTANGLE x:-.20cm y:-.15cm w:.075cm h:.05cm
RECTANGLE x:-.05cm y:-.15cm w:.075cm h:.05cm
RECTANGLE x:0.10cm y:-.15cm w:.075cm h:.05cm
RECTANGLE x:-.20cm y:-.03cm w:.075cm h:.05cm
RECTANGLE x:-.05cm y:-.03cm w:.075cm h:.05cm
RECTANGLE x:0.10cm y:-.03cm w:.075cm h:.05cm
RECTANGLE x:-.20cm y:0.09cm w:.075cm h:.05cm
RECTANGLE x:-.05cm y:0.09cm w:.075cm h:.05cm
RECTANGLE x:0.10cm y:0.09cm w:.075cm h:.05cm
RECTANGLE x:-.20cm y:0.21cm w:.075cm h:.05cm
RECTANGLE x:-.05cm y:0.21cm w:.075cm h:.05cm
RECTANGLE x:0.10cm y:0.21cm w:.075cm h:.05cm
RECTANGLE x:-.05cm y:.55cm w:.1cm h:.03cm
RECTANGLE x:-.05cm y:-.65cm w:.1cm h:.03cm
ELSE
  FILL color:white
  RECTANGLE x:-0.9cm y:-0.65cm w:1.8cm h:1.3cm
  FILL color:whitesmoke
ENDIF
ENDIF
FONT color:(col)
IF (sp = "English")
  ATTR "Name" y:.8cm w:c:2.8cm h:t
ELSE
  ATTR "Bezeichnung" y:.8cm w:c:2.8cm h:t
ENDIF
```

1.1.36 Class "Cost center"

ADONIS BPMS WE Library 3.9:

```
GRAPHREP
SHADOW off
AVAL sp:"Language"
IF (sp = "System")
  IF (_uilang = "de")
    SET sp:"German"
  ELSE
    SET sp:"English"
  ENDIF
ENDIF
AVAL col:"fontcolor"
```

```

AVAL set-default:"no" mono:"Monochrome view"
IF (mono = "yes")
  SET bMono:1
ELSE
  SET bMono:0
ENDIF
IF (bMono)
  FILL color:lightgray
  SET col:(rgbval("black"))
ELSE
  # start - smooth shaded colors
  GRADIENT_RECT x:-1cm y:-.7cm w:2cm h:.4cm style:downdiag
    color1:(rgbval("lightseagreen",1.7)) color2:(rgbval("lightseagreen",0.7))
  FILL style:null
  CLIP_OFF
  # end - smooth shaded colors
ENDIF
RECTANGLE x:-1cm y:-.7cm w:2cm h:.4cm
FILL color:gray
IF (NOT bMono)
  # start - smooth shaded colors
  GRADIENT_RECT x:-1cm y:-.3cm w:.68cm h:1cm style:downdiag
    color1:(rgbval("lightgray",1.7)) color2:(rgbval("lightgray",0.7))
  FILL style:null
  CLIP_OFF
  # end - smooth shaded colors
ENDIF
RECTANGLE x:-1cm y:-.3cm w:.68cm h:1cm
FILL color:white
RECTANGLE x:-.32cm y:-.3cm w:1.32cm h:1cm
IF (NOT bMono)
  PEN w:0.08cm color:$6b6b6b join:miter
ENDIF
FILL style:null
RECTANGLE x:-1cm y:-.7cm w:2cm h:1.4cm
PEN w:0.05cm color:black
SHADOW mode:off
LINE x1:-1cm y1:-.35cm x2:1cm y2:-.35cm
LINE x1:-1cm y1:-.05cm x2:1cm y2:-.05cm
LINE x1:-1cm y1:.2cm x2:1cm y2:.2cm
LINE x1:-1cm y1:.45cm x2:1cm y2:.45cm
LINE x1:.12cm y1:-.3cm x2:.12cm y2:.7cm
LINE x1:.56cm y1:-.3cm x2:.56cm y2:.7cm
FONT color:(col)
IF (sp = "English")
  ATTR "Name" y:.9cm w:c:2.8cm h:t
ELSE
  ATTR "Bezeichnung" y:.9cm w:c:2.8cm h:t
ENDIF
FONT "Arial" h:9pt bold color:black
IF (sp = "English")
  TEXT "Cost center" y:-.7cm w:c:2cm h:t
ELSE
  TEXT "Kostenstelle" y:-.7cm w:c:2cm h:t
ENDIF

```

1.1.37 Class "Aggregation"

ADONIS BPMS WE Library 3.9:

Part IV

```
GRAPHREP layer:-1 sizing:asymmetrical
AVAL sp:"Language"
IF (sp = "System")
  IF (_uilang = "de")
    SET sp:"German"
  ELSE
    SET sp:"English"
  ENDIF
ENDIF
AVAL set-default:"lightgray" f:"Color"
AVAL s:"Lines"
AVAL set-default:"no" mono:"Monochrome view"
AVAL d:"Representation"
AVAL n:"Display name"
IF (d = "inside")
  AVAL col:"Fontcolor"
ELSE
  AVAL col:"fontcolor"
ENDIF
IF (mono = "yes")
  SET bMono:1
ELSE
  SET bMono:0
ENDIF
IF (bMono)
  SET f:"white"
  SET col:(rgbval("black"))
ENDIF
SHADOW off
IF (s = "Dots")
  PEN style:dot
ELSIF (s = "Lines")
  PEN style:dash
ELSIF (s = "Dots/Lines")
  PEN style:dashdot
ELSIF (s = "Bold")
  PEN w:0.05cm
ELSIF (s = "None")
  PEN style:null
ENDIF
FILL color:(rgbval (f))
RECTANGLE x:0.0cm y:0.0cm w:6.0cm h:9.0cm
TABLE x:0.0cm y:0.0cm w:6.0cm h:9.0cm
  rows:3 cols:3
  w1:0.15cm w2:100% w3:.15cm
  h1:.1cm h2:100% h3:.1cm
STRETCH off
FONT h:10pt
IF (n = "Yes")
  AVAL grad:"Font size"
  AVAL typ:"Font style"
  IF (typ = "Standard")
    FONT h:(PT grad)
  ELSIF (typ = "Italic")
    FONT h:(PT grad) italic
  ELSIF (typ = "Bold")
    FONT h:(PT grad) bold
  ELSIF (typ = "Underline")
    FONT h:(PT grad) underline
  ELSIF (typ = "Bold Italic")
    FONT h:(PT grad) bold italic
```

```

ELSIF (typ = "Bold Underline")
  FONT h:(PT grad) bold underline
ENDIF
IF (d = "inside")
  IF (sp = "English")
    ATTR "Name" x:(tabx1) y:(taby1) w:(tabw2) h:(tabh2)
  ELSE
    ATTR "Bezeichnung" x:(tabx1) y:(taby1) w:(tabw2) h:(tabh2)
  ENDIF
ELSE
  IF (sp = "English")
    ATTR "Name" x:(tabx1) y:-.05cm w:(tabw2) h:b
  ELSE
    ATTR "Bezeichnung" x:(tabx1) y:-.05cm w:(tabw2) h:b
  ENDIF
ENDIF
ENDIF

```

1.1.38 Class "Note"

ADONIS BPMS WE Library 3.9:

```

GRAPHREP layer:0 sizing:asymmetrical
SHADOW off
AVAL set-default:"" a:"External graphic"
AVAL sp:"Language"
IF (sp = "System")
  IF (_uilang = "de")
    SET sp:"German"
  ELSE
    SET sp:"English"
  ENDIF
ENDIF
AVAL set-default:"No" autoB:"Calculate size of graphic automatically"
AVAL set-default:"lemonchiffon" f:"Color"
AVAL set-default:"no" mono:"Monochrome view"
IF (mono = "yes")
  SET bMono:1
ELSE
  SET bMono:0
ENDIF
IF (bMono)
  SET f:"white"
ENDIF
SET found:(search(a,"\\",0))
IF (found >= 0)
  IF (found = (LEN a - 1))
    SET s:(search(a,"@",0) + 1)
    SET e:((LEN a) - 1)
  ELSE
    SET s:((found) + 1)
    SET foundend:(search(a,"\\",s))
    IF (foundend >= 0)
      SET e:((LEN a) - 1)
    ELSE
      SET e:(LEN a)
    ENDIF
  ENDIF
ENDIF
ELSE

```

Part IV

```
SET e:(LEN a)
SET s:(search(a,"@",0) + 1)
ENDIF
SET grfk:(copy (a, s, e - s))
SET s:((LEN grfk) - 4)
SET e:((LEN grfk))
SET ext:(copy (grfk, s, e))
# -- build obj --
SET ext:(lower(ext))
# ---
TABLE w:4.5cm h:4.5cm cols:3 rows:3
w1:.15cm w2:100% w3:.15cm
h1:.15cm h2:100% h3:.15cm
STRETCH off
IF (autoB = "No")
  IF ( (ext=".bmp") OR (ext=".gif") OR (ext=".ico") OR (ext=".jpg") OR
(ext=".jpeg") OR (ext=".png") OR (ext=".targa") OR (ext=".tiff") OR (ext=".wbmp")
OR (ext=".xpm") )
BITMAP (grfk) w:(tabw1 + tabw2 + tabw3) h:(tabh1 + tabh2 + tabh3)
ELSE
  PEN color:darkgray outline
  FILL color:(rgbval(f))
  RECTANGLE w:(tabw1 + tabw2 + tabw3) h:(tabh1 + tabh2 + tabh3)
  AVAL grad:"Font size"
  AVAL typ:"Font style"
  IF (typ = "Standard")
    FONT h:(PT grad)
  ELSIF (typ = "Italic")
    FONT h:(PT grad) italic
  ELSIF (typ = "Bold")
    FONT h:(PT grad) bold
  ELSIF (typ = "Underline")
    FONT h:(PT grad) underline
  ELSIF (typ = "Bold Italic")
    FONT h:(PT grad) bold italic
  ELSIF (typ = "Bold Underline")
    FONT h:(PT grad) bold underline
  ENDIF
  IF (sp="English")
    ATTR "Text" x:(tabx1) y:(taby1) w:(tabw2) h:(tabh2)
  ELSE
    ATTR "Notiz" x:(tabx1) y:(taby1) w:(tabw2) h:(tabh2)
  ENDIF
ENDIF
# ---
ELSIF (autoB = "Yes")
# SET d:4.5cm # default width and height
# PEN color:white
# FILL style:null
# SHADOW off
# RECTANGLE w:(d) h:(d) # a border marking the object's size
# SHADOW on
  IF ( (ext=".bmp") OR (ext=".gif") OR (ext=".ico") OR (ext=".jpg") OR
(ext=".jpeg") OR (ext=".png") OR (ext=".targa") OR (ext=".tiff") OR (ext=".wbmp")
OR (ext=".xpm") )
    BITMAPINFO (grfk) # get the bitmap size
    STRETCH off
    IF (bmpwidth > bmpheight)
# use maximum height, space left and right
# SET w:(tabh1 * (bmpwidth / bmpheight))
# SET h:(tabh1)
```



```

        SET w:(tabw1 + tabw2 + tabw3)
        SET h:(((tabw1 + tabw2 + tabw3) * bmpheight) / bmpwidth)
        BITMAP (grfk) x:0cm y:0cm w:(w) h:(h)
        #BITMAP (grfk) x:0cm y:0cm w:(CM bmpwidth) h:(CM bmpheight)
    ELSE
# use maximum width, space at top and bottom
#     SET h:(tabw1 * (bmpheight / bmpwidth))
#     SET w:(tabw1)
        SET w:(((tabh1 + tabh2 + tabh3) * bmpwidth) / bmpheight)
        SET h:(tabh1 + tabh2 + tabh3)
        BITMAP (grfk) x:0cm y:0cm w:(w) h:(h)
    ENDIF
ELSE
    PEN color:darkgray outline
    FILL color:(rgbval(f))
    RECTANGLE w:(tabw1 + tabw2 + tabw3) h:(tabh1 + tabh2 + tabh3)
    AVAL grad:"Font size"
    AVAL typ:"Font style"
    IF (typ = "Standard")
        FONT h:(PT grad)
    ELSIF (typ = "Italic")
        FONT h:(PT grad) italic
    ELSIF (typ = "Bold")
        FONT h:(PT grad) bold
    ELSIF (typ = "Underline")
        FONT h:(PT grad) underline
    ELSIF (typ = "Bold Italic")
        FONT h:(PT grad) bold italic
    ELSIF (typ = "Bold Underline")
        FONT h:(PT grad) bold underline
    ENDIF
    IF (sp="English")
        ATTR "Text" x:(tabx1) y:(taby1) w:(tabw2) h:(tabh2)
    ELSE
        ATTR "Notiz" x:(tabx1) y:(taby1) w:(tabw2) h:(tabh2)
    ENDIF
ENDIF
ENDIF
ENDIF

```

1.1.39 Class "Swimlane (horizontal)"

ADONIS BPMS WE Library 3.9:

```

GRAPHREP swimlane:horizontal layer:-3
SHADOW off
AVAL o:"Working environment"
PEN style:null
AVAL set-default:"$ffffff" c:"Color"
AVAL cl:"Fontcolor"
AVAL or:"Alignment"
AVAL w:"Display water marks"
AVAL sp:"Language"
IF (sp = "System")
    IF (_uilang = "de")
        SET sp:"German"
    ELSE
        SET sp:"English"
    ENDIF
ENDIF
ENDIF

```

Part IV

```
FILL color:(rgbval (c))
PEN color:black
RECTANGLE w:6cm h:4cm
TABLE rows:3 cols:2 w:6cm h:4cm w1:4cm w2:100% h1:0.1cm h2:100% h3:0.1cm
STRETCH off
IF (sp = "English")
  AVAL set-format:"%o" sInterrefText:"Working environment"
ELSE
  AVAL sInterrefText:"refObjectNameDE"
ENDIF
FONT color:(c1) h:14pt bold
IF (o="")
  IF (sp = "English")
    IF (or = "central")
      ATTR "Name" x:(tabx0 + (tabw1 / 2)) y:(taby1 + (tabh2 / 2)) w:c:(tabw1)
h:c:(tabh2) line-break:rigorous
    ELSIF (or = "top")
      ATTR "Name" x:(tabx0 + (tabw1 / 2)) y:(taby1) w:c:(tabw1) h:t:(tabh2) line-
break:rigorous
    ELSE
      ATTR "Name" x:(tabx0 + (tabw1 / 2)) y:(taby2) w:c:(tabw1) h:b:(tabh2) line-
break:rigorous
    ENDIF
    IF (w="yes")
      IF ((tabw1 + tabw2) > 30cm)
        SET cl:$b5b5b5
        FONT color:(c1) h:14pt bold
        IF (or = "central")
          ATTR "Name" x:19.0cm y:(taby1 + (tabh2 / 2)) w:c:(tabw1) h:c:(tabh2)
line-break:rigorous
        ELSIF (or = "top")
          ATTR "Name" x:19.0cm y:(taby1) w:c:(tabw1) h:t:(tabh2) line-
break:rigorous
        ELSE
          ATTR "Name" x:19.0cm y:(taby2) w:c:(tabw1) h:b:(tabh2) line-
break:rigorous
        ENDIF
      ENDIF
      IF ((tabw1 + tabw2) > 50cm)
        IF (or = "central")
          ATTR "Name" x:38.0cm y:(taby1 + (tabh2 / 2)) w:c:(tabw1) h:c:(tabh2)
line-break:rigorous
        ELSIF (or = "top")
          ATTR "Name" x:38.0cm y:(taby1) w:c:(tabw1) h:t:(tabh2) line-
break:rigorous
        ELSE
          ATTR "Name" x:38.0cm y:(taby2) w:c:(tabw1) h:b:(tabh2) line-
break:rigorous
        ENDIF
      ENDIF
      IF ((tabw1 + tabw2) > 70cm)
        IF (or = "central")
          ATTR "Name" x:57.0cm y:(taby1 + (tabh2 / 2)) w:c:(tabw1) h:c:(tabh2)
line-break:rigorous
        ELSIF (or = "top")
          ATTR "Name" x:57.0cm y:(taby1) w:c:(tabw1) h:t:(tabh2) line-
break:rigorous
        ELSE
          ATTR "Name" x:57.0cm y:(taby2) w:c:(tabw1) h:b:(tabh2) line-
break:rigorous
        ENDIF
      ENDIF
    ENDIF
  ENDIF

```

```

ENDIF
IF ((tabw1 + tabw2) > 90cm)
  IF (or = "central")
    ATTR "Name" x:76.0cm y:(taby1 + (tabh2 / 2)) w:c:(tabw1) h:c:(tabh2)
line-break:rigorous
  ELSIF (or = "top")
    ATTR "Name" x:76.0cm y:(taby1) w:c:(tabw1) h:t:(tabh2) line-
break:rigorous
  ELSE
    ATTR "Name" x:76.0cm y:(taby2) w:c:(tabw1) h:b:(tabh2) line-
break:rigorous
  ENDIF
ENDIF
IF ((tabw1 + tabw2) > 110cm)
  IF (or = "central")
    ATTR "Name" x:95.0cm y:(taby1 + (tabh2 / 2)) w:c:(tabw1) h:c:(tabh2)
line-break:rigorous
  ELSIF (or = "top")
    ATTR "Name" x:95.0cm y:(taby1) w:c:(tabw1) h:t:(tabh2) line-
break:rigorous
  ELSE
    ATTR "Name" x:95.0cm y:(taby2) w:c:(tabw1) h:b:(tabh2) line-
break:rigorous
  ENDIF
ENDIF
IF ((tabw1 + tabw2) > 130cm)
  IF (or = "central")
    ATTR "Name" x:114.0cm y:(taby1 + (tabh2 / 2)) w:c:(tabw1) h:c:(tabh2)
line-break:rigorous
  ELSIF (or = "top")
    ATTR "Name" x:114.0cm y:(taby1) w:c:(tabw1) h:t:(tabh2) line-
break:rigorous
  ELSE
    ATTR "Name" x:114.0cm y:(taby2) w:c:(tabw1) h:b:(tabh2) line-
break:rigorous
  ENDIF
ENDIF
IF ((tabw1 + tabw2) > 150cm)
  IF (or = "central")
    ATTR "Name" x:133.0cm y:(taby1 + (tabh2 / 2)) w:c:(tabw1) h:c:(tabh2)
line-break:rigorous
  ELSIF (or = "top")
    ATTR "Name" x:133.0cm y:(taby1) w:c:(tabw1) h:t:(tabh2) line-
break:rigorous
  ELSE
    ATTR "Name" x:133.0cm y:(taby2) w:c:(tabw1) h:b:(tabh2) line-
break:rigorous
  ENDIF
ENDIF
IF ((tabw1 + tabw2) > 170cm)
  IF (or = "central")
    ATTR "Name" x:152.0cm y:(taby1 + (tabh2 / 2)) w:c:(tabw1) h:c:(tabh2)
line-break:rigorous
  ELSIF (or = "top")
    ATTR "Name" x:152.0cm y:(taby1) w:c:(tabw1) h:t:(tabh2) line-
break:rigorous
  ELSE
    ATTR "Name" x:152.0cm y:(taby2) w:c:(tabw1) h:b:(tabh2) line-
break:rigorous
  ENDIF
ENDIF
ENDIF

```

Part IV

```
IF ((tabw1 + tabw2) > 190cm)
  IF (or = "central")
    ATTR "Name" x:171.0cm y:(taby1 + (tabh2 / 2)) w:c:(tabw1) h:c:(tabh2)
line-break:rigorous
  ELSIF (or = "top")
    ATTR "Name" x:171.0cm y:(taby1) w:c:(tabw1) h:t:(tabh2) line-
break:rigorous
  ELSE
    ATTR "Name" x:171.0cm y:(taby2) w:c:(tabw1) h:b:(tabh2) line-
break:rigorous
  ENDIF
ENDIF
IF ((tabw1 + tabw2) > 210cm)
  IF (or = "central")
    ATTR "Name" x:190.0cm y:(taby1 + (tabh2 / 2)) w:c:(tabw1) h:c:(tabh2)
line-break:rigorous
  ELSIF (or = "top")
    ATTR "Name" x:190.0cm y:(taby1) w:c:(tabw1) h:t:(tabh2) line-
break:rigorous
  ELSE
    ATTR "Name" x:190.0cm y:(taby2) w:c:(tabw1) h:b:(tabh2) line-
break:rigorous
  ENDIF
ENDIF
IF ((tabw1 + tabw2) > 230cm)
  IF (or = "central")
    ATTR "Name" x:209.0cm y:(taby1 + (tabh2 / 2)) w:c:(tabw1) h:c:(tabh2)
line-break:rigorous
  ELSIF (or = "top")
    ATTR "Name" x:209.0cm y:(taby1) w:c:(tabw1) h:t:(tabh2) line-
break:rigorous
  ELSE
    ATTR "Name" x:209.0cm y:(taby2) w:c:(tabw1) h:b:(tabh2) line-
break:rigorous
  ENDIF
ENDIF
ENDIF
ELSE
  IF (or = "central")
    ATTR "Bezeichnung" x:(tabx0 + (tabw1 / 2)) y:(taby1 + (tabh2 / 2))
w:c:(tabw1) h:c:(tabh2) line-break:rigorous
  ELSIF (or = "top")
    ATTR "Bezeichnung" x:(tabx0 + (tabw1 / 2)) y:(taby1) w:c:(tabw1) h:t:(tabh2)
line-break:rigorous
  ELSE
    ATTR "Bezeichnung" x:(tabx0 + (tabw1 / 2)) y:(taby2) w:c:(tabw1) h:b:(tabh2)
line-break:rigorous
  ENDIF
  IF (w="yes")
    IF ((tabw1 + tabw2) > 30cm)
      SET cl:$b5b5b5
      FONT color:(cl) h:14pt bold
      IF (or = "central")
        ATTR "Bezeichnung" x:19.0cm y:(taby1 + (tabh2 / 2)) w:c:(tabw1)
h:c:(tabh2) line-break:rigorous
      ELSIF (or = "top")
        ATTR "Bezeichnung" x:19.0cm y:(taby1) w:c:(tabw1) h:t:(tabh2) line-
break:rigorous
      ELSE
        ATTR "Bezeichnung" x:19.0cm y:(taby2) w:c:(tabw1) h:b:(tabh2) line-
break:rigorous
      ENDIF
    ENDIF
  ENDIF
ENDIF
```

```

        ENDIF
    ENDIF
    IF ((tabw1 + tabw2) > 50cm)
        IF (or = "central")
            ATTR "Bezeichnung" x:38.0cm y:(taby1 + (tabh2 / 2)) w:c:(tabw1)
h:c:(tabh2) line-break:rigorous
        ELSIF (or = "top")
            ATTR "Bezeichnung" x:38.0cm y:(taby1) w:c:(tabw1) h:t:(tabh2) line-
break:rigorous
        ELSE
            ATTR "Bezeichnung" x:38.0cm y:(taby2) w:c:(tabw1) h:b:(tabh2) line-
break:rigorous
        ENDIF
    ENDIF
    IF ((tabw1 + tabw2) > 70cm)
        IF (or = "central")
            ATTR "Bezeichnung" x:57.0cm y:(taby1 + (tabh2 / 2)) w:c:(tabw1)
h:c:(tabh2) line-break:rigorous
        ELSIF (or = "top")
            ATTR "Bezeichnung" x:57.0cm y:(taby1) w:c:(tabw1) h:t:(tabh2) line-
break:rigorous
        ELSE
            ATTR "Bezeichnung" x:57.0cm y:(taby2) w:c:(tabw1) h:b:(tabh2) line-
break:rigorous
        ENDIF
    ENDIF
    IF ((tabw1 + tabw2) > 90cm)
        IF (or = "central")
            ATTR "Bezeichnung" x:76.0cm y:(taby1 + (tabh2 / 2)) w:c:(tabw1)
h:c:(tabh2) line-break:rigorous
        ELSIF (or = "top")
            ATTR "Bezeichnung" x:76.0cm y:(taby1) w:c:(tabw1) h:t:(tabh2) line-
break:rigorous
        ELSE
            ATTR "Bezeichnung" x:76.0cm y:(taby2) w:c:(tabw1) h:b:(tabh2) line-
break:rigorous
        ENDIF
    ENDIF
    IF ((tabw1 + tabw2) > 110cm)
        IF (or = "central")
            ATTR "Bezeichnung" x:95.0cm y:(taby1 + (tabh2 / 2)) w:c:(tabw1)
h:c:(tabh2) line-break:rigorous
        ELSIF (or = "top")
            ATTR "Bezeichnung" x:95.0cm y:(taby1) w:c:(tabw1) h:t:(tabh2) line-
break:rigorous
        ELSE
            ATTR "Bezeichnung" x:95.0cm y:(taby2) w:c:(tabw1) h:b:(tabh2) line-
break:rigorous
        ENDIF
    ENDIF
    IF ((tabw1 + tabw2) > 130cm)
        IF (or = "central")
            ATTR "Bezeichnung" x:114.0cm y:(taby1 + (tabh2 / 2)) w:c:(tabw1)
h:c:(tabh2) line-break:rigorous
        ELSIF (or = "top")
            ATTR "Bezeichnung" x:114.0cm y:(taby1) w:c:(tabw1) h:t:(tabh2) line-
break:rigorous
        ELSE
            ATTR "Bezeichnung" x:114.0cm y:(taby2) w:c:(tabw1) h:b:(tabh2) line-
break:rigorous
        ENDIF
    ENDIF

```

Part IV

```
ENDIF
IF ((tabw1 + tabw2) > 150cm)
  IF (or = "central")
    ATTR "Bezeichnung" x:133.0cm y:(taby1 + (tabh2 / 2)) w:c:(tabw1)
h:c:(tabh2) line-break:rigorous
    ELSIF (or = "top")
    ATTR "Bezeichnung" x:133.0cm y:(taby1) w:c:(tabw1) h:t:(tabh2) line-
break:rigorous
    ELSE
    ATTR "Bezeichnung" x:133.0cm y:(taby2) w:c:(tabw1) h:b:(tabh2) line-
break:rigorous
    ENDIF
  ENDIF
ENDIF
IF ((tabw1 + tabw2) > 170cm)
  IF (or = "central")
    ATTR "Bezeichnung" x:152.0cm y:(taby1 + (tabh2 / 2)) w:c:(tabw1)
h:c:(tabh2) line-break:rigorous
    ELSIF (or = "top")
    ATTR "Bezeichnung" x:152.0cm y:(taby1) w:c:(tabw1) h:t:(tabh2) line-
break:rigorous
    ELSE
    ATTR "Bezeichnung" x:152.0cm y:(taby2) w:c:(tabw1) h:b:(tabh2) line-
break:rigorous
    ENDIF
  ENDIF
ENDIF
IF ((tabw1 + tabw2) > 190cm)
  IF (or = "central")
    ATTR "Bezeichnung" x:171.0cm y:(taby1 + (tabh2 / 2)) w:c:(tabw1)
h:c:(tabh2) line-break:rigorous
    ELSIF (or = "top")
    ATTR "Bezeichnung" x:171.0cm y:(taby1) w:c:(tabw1) h:t:(tabh2) line-
break:rigorous
    ELSE
    ATTR "Bezeichnung" x:171.0cm y:(taby2) w:c:(tabw1) h:b:(tabh2) line-
break:rigorous
    ENDIF
  ENDIF
ENDIF
IF ((tabw1 + tabw2) > 210cm)
  IF (or = "central")
    ATTR "Bezeichnung" x:190.0cm y:(taby1 + (tabh2 / 2)) w:c:(tabw1)
h:c:(tabh2) line-break:rigorous
    ELSIF (or = "top")
    ATTR "Bezeichnung" x:190.0cm y:(taby1) w:c:(tabw1) h:t:(tabh2) line-
break:rigorous
    ELSE
    ATTR "Bezeichnung" x:190.0cm y:(taby2) w:c:(tabw1) h:b:(tabh2) line-
break:rigorous
    ENDIF
  ENDIF
ENDIF
IF ((tabw1 + tabw2) > 230cm)
  IF (or = "central")
    ATTR "Bezeichnung" x:209.0cm y:(taby1 + (tabh2 / 2)) w:c:(tabw1)
h:c:(tabh2) line-break:rigorous
    ELSIF (or = "top")
    ATTR "Bezeichnung" x:209.0cm y:(taby1) w:c:(tabw1) h:t:(tabh2) line-
break:rigorous
    ELSE
    ATTR "Bezeichnung" x:209.0cm y:(taby2) w:c:(tabw1) h:b:(tabh2) line-
break:rigorous
    ENDIF
  ENDIF
ENDIF
ENDIF
```

```

ENDIF
ENDIF
ELSE
  IF (or = "central")
    ATTR "Working environment" text:(sInterrefText) format:"%o" x:(tabx0 + (tabw1 /
2)) y:(taby1 + (tabh2 / 2)) w:c:(tabw1) h:c:(tabh2) line-break:rigorous
    ELSIF (or = "top")
      ATTR "Working environment" text:(sInterrefText) format:"%o" x:(tabx0 + (tabw1 /
2)) y:(taby1) w:c:(tabw1) h:t:(tabh2) line-break:rigorous
    ELSE
      ATTR "Working environment" text:(sInterrefText) format:"%o" x:(tabx0 + (tabw1 /
2)) y:(taby2) w:c:(tabw1) h:b:(tabh2) line-break:rigorous
    ENDIF
  IF (w="yes")
    IF ((tabw1 + tabw2) > 30cm)
      SET cl:$b5b5b5
      FONT color:(cl) h:14pt bold
      IF (or = "central")
        ATTR "Working environment" text:(sInterrefText) format:"%o" x:19.0cm
y:(taby1 + (tabh2 / 2)) w:c:(tabw1) h:c:(tabh2) line-break:rigorous
        ELSIF (or = "top")
          ATTR "Working environment" text:(sInterrefText) format:"%o" x:19.0cm
y:(taby1) w:c:(tabw1) h:t:(tabh2) line-break:rigorous
        ELSE
          ATTR "Working environment" text:(sInterrefText) format:"%o" x:19.0cm
y:(taby2) w:c:(tabw1) h:b:(tabh2) line-break:rigorous
        ENDIF
      ENDIF
      IF ((tabw1 + tabw2) > 50cm)
        IF (or = "central")
          ATTR "Working environment" text:(sInterrefText) format:"%o" x:38.0cm
y:(taby1 + (tabh2 / 2)) w:c:(tabw1) h:c:(tabh2) line-break:rigorous
          ELSIF (or = "top")
            ATTR "Working environment" text:(sInterrefText) format:"%o" x:38.0cm
y:(taby1) w:c:(tabw1) h:t:(tabh2) line-break:rigorous
          ELSE
            ATTR "Working environment" text:(sInterrefText) format:"%o" x:38.0cm
y:(taby2) w:c:(tabw1) h:b:(tabh2) line-break:rigorous
          ENDIF
        ENDIF
        IF ((tabw1 + tabw2) > 70cm)
          IF (or = "central")
            ATTR "Working environment" text:(sInterrefText) format:"%o" x:57.0cm
y:(taby1 + (tabh2 / 2)) w:c:(tabw1) h:c:(tabh2) line-break:rigorous
            ELSIF (or = "top")
              ATTR "Working environment" text:(sInterrefText) format:"%o" x:57.0cm
y:(taby1) w:c:(tabw1) h:t:(tabh2) line-break:rigorous
            ELSE
              ATTR "Working environment" text:(sInterrefText) format:"%o" x:57.0cm
y:(taby2) w:c:(tabw1) h:b:(tabh2) line-break:rigorous
            ENDIF
          ENDIF
          IF ((tabw1 + tabw2) > 90cm)
            IF (or = "central")
              ATTR "Working environment" text:(sInterrefText) format:"%o" x:76.0cm
y:(taby1 + (tabh2 / 2)) w:c:(tabw1) h:c:(tabh2) line-break:rigorous
              ELSIF (or = "top")
                ATTR "Working environment" text:(sInterrefText) format:"%o" x:76.0cm
y:(taby1) w:c:(tabw1) h:t:(tabh2) line-break:rigorous
            ELSE
              ATTR "Working environment" text:(sInterrefText) format:"%o" x:76.0cm
y:(taby2) w:c:(tabw1) h:b:(tabh2) line-break:rigorous
            ENDIF
          ENDIF
        ENDIF
      ENDIF
    ENDIF
  ENDIF

```

Part IV

```
        ATTR "Working environment" text:(sInterrefText) format:"%o" x:76.0cm
y:(taby2) w:c:(tabw1) h:b:(tabh2) line-break:rigorous
    ENDIF
ENDIF
IF ((tabw1 + tabw2) > 110cm)
    IF (or = "central")
        ATTR "Working environment" text:(sInterrefText) format:"%o" x:95.0cm
y:(taby1 + (tabh2 / 2)) w:c:(tabw1) h:c:(tabh2) line-break:rigorous
        ELSIF (or = "top")
            ATTR "Working environment" text:(sInterrefText) format:"%o" x:95.0cm
y:(taby1) w:c:(tabw1) h:t:(tabh2) line-break:rigorous
        ELSE
            ATTR "Working environment" text:(sInterrefText) format:"%o" x:95.0cm
y:(taby2) w:c:(tabw1) h:b:(tabh2) line-break:rigorous
        ENDIF
    ENDIF
IF ((tabw1 + tabw2) > 130cm)
    IF (or = "central")
        ATTR "Working environment" text:(sInterrefText) format:"%o" x:114.0cm
y:(taby1 + (tabh2 / 2)) w:c:(tabw1) h:c:(tabh2) line-break:rigorous
        ELSIF (or = "top")
            ATTR "Working environment" text:(sInterrefText) format:"%o" x:114.0cm
y:(taby1) w:c:(tabw1) h:t:(tabh2) line-break:rigorous
        ELSE
            ATTR "Working environment" text:(sInterrefText) format:"%o" x:114.0cm
y:(taby2) w:c:(tabw1) h:b:(tabh2) line-break:rigorous
        ENDIF
    ENDIF
IF ((tabw1 + tabw2) > 150cm)
    IF (or = "central")
        ATTR "Working environment" text:(sInterrefText) format:"%o" x:133.0cm
y:(taby1 + (tabh2 / 2)) w:c:(tabw1) h:c:(tabh2) line-break:rigorous
        ELSIF (or = "top")
            ATTR "Working environment" text:(sInterrefText) format:"%o" x:133.0cm
y:(taby1) w:c:(tabw1) h:t:(tabh2) line-break:rigorous
        ELSE
            ATTR "Working environment" text:(sInterrefText) format:"%o" x:133.0cm
y:(taby2) w:c:(tabw1) h:b:(tabh2) line-break:rigorous
        ENDIF
    ENDIF
IF ((tabw1 + tabw2) > 170cm)
    IF (or = "central")
        ATTR "Working environment" text:(sInterrefText) format:"%o" x:152.0cm
y:(taby1 + (tabh2 / 2)) w:c:(tabw1) h:c:(tabh2) line-break:rigorous
        ELSIF (or = "top")
            ATTR "Working environment" text:(sInterrefText) format:"%o" x:152.0cm
y:(taby1) w:c:(tabw1) h:t:(tabh2) line-break:rigorous
        ELSE
            ATTR "Working environment" text:(sInterrefText) format:"%o" x:152.0cm
y:(taby2) w:c:(tabw1) h:b:(tabh2) line-break:rigorous
        ENDIF
    ENDIF
IF ((tabw1 + tabw2) > 190cm)
    IF (or = "central")
        ATTR "Working environment" text:(sInterrefText) format:"%o" x:171.0cm
y:(taby1 + (tabh2 / 2)) w:c:(tabw1) h:c:(tabh2) line-break:rigorous
        ELSIF (or = "top")
            ATTR "Working environment" text:(sInterrefText) format:"%o" x:171.0cm
y:(taby1) w:c:(tabw1) h:t:(tabh2) line-break:rigorous
        ELSE
```



```

        ATTR "Working environment" text:(sInterrefText) format:"%o" x:171.0cm
y:(taby2) w:c:(tabw1) h:b:(tabh2) line-break:rigorous
    ENDF
ENDIF
    IF ((tabw1 + tabw2) > 210cm)
        IF (or = "central")
            ATTR "Working environment" text:(sInterrefText) format:"%o" x:190.0cm
y:(taby1 + (tabh2 / 2)) w:c:(tabw1) h:c:(tabh2) line-break:rigorous
            ELSIF (or = "top")
                ATTR "Working environment" text:(sInterrefText) format:"%o" x:190.0cm
y:(taby1) w:c:(tabw1) h:t:(tabh2) line-break:rigorous
            ELSE
                ATTR "Working environment" text:(sInterrefText) format:"%o" x:190.0cm
y:(taby2) w:c:(tabw1) h:b:(tabh2) line-break:rigorous
            ENDF
        ENDF
    IF ((tabw1 + tabw2) > 230cm)
        IF (or = "central")
            ATTR "Working environment" text:(sInterrefText) format:"%o" x:209.0cm
y:(taby1 + (tabh2 / 2)) w:c:(tabw1) h:c:(tabh2) line-break:rigorous
            ELSIF (or = "top")
                ATTR "Working environment" text:(sInterrefText) format:"%o" x:209.0cm
y:(taby1) w:c:(tabw1) h:t:(tabh2) line-break:rigorous
            ELSE
                ATTR "Working environment" text:(sInterrefText) format:"%o" x:209.0cm
y:(taby2) w:c:(tabw1) h:b:(tabh2) line-break:rigorous
            ENDF
        ENDF
    ENDF
ENDIF
AVAL set-default:"_undefined_" sHelp:"Name"
IF (sHelp = "_undefined_")
    LINE x1:2.0cm y1:0.0cm x2:2.0cm y2:4.0cm
ELSE
    LINE x1:(tabx1) y1:(taby0) x2:(tabx1) y2:(taby3)
ENDIF

```

1.1.40 Class "Swimlane (vertical)"

ADONIS BPMS WE Library 3.9:

```

GRAPHREP swimlane:vertical
SHADOW off
AVAL o:"Working environment"
PEN style:null
AVAL set-default:"$ffffff" c:"Color"
AVAL cl:"Fontcolor"
AVAL or:"Alignment"
AVAL w:"Display water marks"
AVAL sp:"Language"
IF (sp = "System")
    IF (_uilang = "de")
        SET sp:"German"
    ELSE
        SET sp:"English"
    ENDF
ENDIF
FILL color:(rgbval (c))
PEN color:black

```

Part IV

```
RECTANGLE w:4cm h:6cm
TABLE rows:2 cols:3 w:4cm h:6cm h1:4cm h2:100% w1:.1cm w2:100% w3:.1cm
STRETCH off
FONT color:(col) h:14pt bold
IF (sp = "English")
  AVAL set-format:"%o" sInterrefText:"Working environment"
ELSE
  AVAL sInterrefText:"refObjectNameDE"
ENDIF
IF (o="")
  IF (sp = "English")
    IF (or = "central")
      ATTR "Name" x:(tabx1 + (tabw2 / 2)) y:(taby0 + tabh1 / 2) w:c:(tabw2)
h:c:(tabh1) line-break:rigorous
    ELSIF (or = "left")
      ATTR "Name" x:(tabx1) y:(taby0 + tabh1 / 2) w:l:(tabw2) h:c:(tabh1) line-
break:rigorous
    ELSE
      ATTR "Name" x:(tabx2) y:(taby0 + tabh1 / 2) w:r:(tabw2) h:c:(tabh1) line-
break:rigorous
    ENDIF
  IF (w="yes")
    IF ((tabh1 + tabh2) > 20cm)
      SET cl:$b5b5b5
      FONT color:(cl) h:14pt bold
      IF (or = "central")
        ATTR "Name" x:(tabx1 + (tabw2 / 2)) y:14cm w:c:(tabw2) h:c:(tabh1) line-
break:rigorous
      ELSIF (or = "left")
        ATTR "Name" x:(tabx1) y:14cm w:l:(tabw2) h:c:(tabh1) line-break:rigorous
      ELSE
        ATTR "Name" x:(tabx2) y:14cm w:r:(tabw2) h:c:(tabh1) line-break:rigorous
      ENDIF
    ENDIF
    IF ((tabh1 + tabh2) > 35cm)
      IF (or = "central")
        ATTR "Name" x:(tabx1 + (tabw2 / 2)) y:28cm w:c:(tabw2) h:c:(tabh1) line-
break:rigorous
      ELSIF (or = "left")
        ATTR "Name" x:(tabx1) y:28cm w:l:(tabw2) h:c:(tabh1) line-break:rigorous
      ELSE
        ATTR "Name" x:(tabx2) y:28cm w:r:(tabw2) h:c:(tabh1) line-break:rigorous
      ENDIF
    ENDIF
    IF ((tabh1 + tabh2) > 50cm)
      IF (or = "central")
        ATTR "Name" x:(tabx1 + (tabw2 / 2)) y:42cm w:c:(tabw2) h:c:(tabh1) line-
break:rigorous
      ELSIF (or = "left")
        ATTR "Name" x:(tabx1) y:42cm w:l:(tabw2) h:c:(tabh1) line-break:rigorous
      ELSE
        ATTR "Name" x:(tabx2) y:42cm w:r:(tabw2) h:c:(tabh1) line-break:rigorous
      ENDIF
    ENDIF
    IF ((tabh1 + tabh2) > 65cm)
      IF (or = "central")
        ATTR "Name" x:(tabx1 + (tabw2 / 2)) y:56cm w:c:(tabw2) h:c:(tabh1) line-
break:rigorous
      ELSIF (or = "left")
        ATTR "Name" x:(tabx1) y:56cm w:l:(tabw2) h:c:(tabh1) line-break:rigorous
      ELSE

```

```

        ATTR "Name" x:(tabx2) y:56cm w:r:(tabw2) h:c:(tabh1) line-break:rigorous
    ENDIF
ENDIF
IF ((tabh1 + tabh2) > 80cm)
    IF (or = "central")
        ATTR "Name" x:(tabx1 + (tabw2 / 2)) y:70cm w:c:(tabw2) h:c:(tabh1) line-
break:rigorous
    ELSIF (or = "left")
        ATTR "Name" x:(tabx1) y:70cm w:l:(tabw2) h:c:(tabh1) line-break:rigorous
    ELSE
        ATTR "Name" x:(tabx2) y:70cm w:r:(tabw2) h:c:(tabh1) line-break:rigorous
    ENDIF
ENDIF
IF ((tabh1 + tabh2) > 95cm)
    IF (or = "central")
        ATTR "Name" x:(tabx1 + (tabw2 / 2)) y:84cm w:c:(tabw2) h:c:(tabh1) line-
break:rigorous
    ELSIF (or = "left")
        ATTR "Name" x:(tabx1) y:84cm w:l:(tabw2) h:c:(tabh1) line-break:rigorous
    ELSE
        ATTR "Name" x:(tabx2) y:84cm w:r:(tabw2) h:c:(tabh1) line-break:rigorous
    ENDIF
ENDIF
IF ((tabh1 + tabh2) > 110cm)
    IF (or = "central")
        ATTR "Name" x:(tabx1 + (tabw2 / 2)) y:98cm w:c:(tabw2) h:c:(tabh1) line-
break:rigorous
    ELSIF (or = "left")
        ATTR "Name" x:(tabx1) y:98cm w:l:(tabw2) h:c:(tabh1) line-break:rigorous
    ELSE
        ATTR "Name" x:(tabx2) y:98cm w:r:(tabw2) h:c:(tabh1) line-break:rigorous
    ENDIF
ENDIF
IF ((tabh1 + tabh2) > 125cm)
    IF (or = "central")
        ATTR "Name" x:(tabx1 + (tabw2 / 2)) y:112cm w:c:(tabw2) h:c:(tabh1) line-
break:rigorous
    ELSIF (or = "left")
        ATTR "Name" x:(tabx1) y:112cm w:l:(tabw2) h:c:(tabh1) line-break:rigorous
    ELSE
        ATTR "Name" x:(tabx2) y:112cm w:r:(tabw2) h:c:(tabh1) line-break:rigorous
    ENDIF
ENDIF
IF ((tabh1 + tabh2) > 140cm)
    IF (or = "central")
        ATTR "Name" x:(tabx1 + (tabw2 / 2)) y:126cm w:c:(tabw2) h:c:(tabh1) line-
break:rigorous
    ELSIF (or = "left")
        ATTR "Name" x:(tabx1) y:126cm w:l:(tabw2) h:c:(tabh1) line-break:rigorous
    ELSE
        ATTR "Name" x:(tabx2) y:126cm w:r:(tabw2) h:c:(tabh1) line-break:rigorous
    ENDIF
ENDIF
IF ((tabh1 + tabh2) > 155cm)
    IF (or = "central")
        ATTR "Name" x:(tabx1 + (tabw2 / 2)) y:140cm w:c:(tabw2) h:c:(tabh1) line-
break:rigorous
    ELSIF (or = "left")
        ATTR "Name" x:(tabx1) y:140cm w:l:(tabw2) h:c:(tabh1) line-break:rigorous
    ELSE
        ATTR "Name" x:(tabx2) y:140cm w:r:(tabw2) h:c:(tabh1) line-break:rigorous

```

Part IV

```
        ENDIF
    ENDIF
    IF ((tabh1 + tabh2) > 170cm)
        IF (or = "central")
            ATTR "Name" x:(tabx1 + (tabw2 / 2)) y:154cm w:c:(tabw2) h:c:(tabh1) line-
break:rigorous
        ELSIF (or = "left")
            ATTR "Name" x:(tabx1) y:154cm w:l:(tabw2) h:c:(tabh1) line-break:rigorous
        ELSE
            ATTR "Name" x:(tabx2) y:154cm w:r:(tabw2) h:c:(tabh1) line-break:rigorous
        ENDIF
    ENDIF
    ENDIF
    ELSE
        IF (or = "central")
            ATTR "Bezeichnung" x:(tabx1 + (tabw2 / 2)) y:(taby0 + tabh1 / 2) w:c:(tabw2)
h:c:(tabh1) line-break:rigorous
        ELSIF (or = "left")
            ATTR "Bezeichnung" x:(tabx1) y:(taby0 + tabh1 / 2) w:l:(tabw2) h:c:(tabh1)
line-break:rigorous
        ELSE
            ATTR "Bezeichnung" x:(tabx2) y:(taby0 + tabh1 / 2) w:r:(tabw2) h:c:(tabh1)
line-break:rigorous
        ENDIF
        IF (w="yes")
            IF ((tabh1 + tabh2) > 20cm)
                SET cl:$b5b5b5
                FONT color:(cl) h:14pt bold
                IF (or = "central")
                    ATTR "Bezeichnung" x:(tabx1 + (tabw2 / 2)) y:14cm w:c:(tabw2) h:c:(tabh1)
line-break:rigorous
                ELSIF (or = "left")
                    ATTR "Bezeichnung" x:(tabx1) y:14cm w:l:(tabw2) h:c:(tabh1) line-
break:rigorous
                ELSE
                    ATTR "Bezeichnung" x:(tabx2) y:14cm w:r:(tabw2) h:c:(tabh1) line-
break:rigorous
                ENDIF
            ENDIF
            IF ((tabh1 + tabh2) > 35cm)
                IF (or = "central")
                    ATTR "Bezeichnung" x:(tabx1 + (tabw2 / 2)) y:28cm w:c:(tabw2) h:c:(tabh1)
line-break:rigorous
                ELSIF (or = "left")
                    ATTR "Bezeichnung" x:(tabx1) y:28cm w:l:(tabw2) h:c:(tabh1) line-
break:rigorous
                ELSE
                    ATTR "Bezeichnung" x:(tabx2) y:28cm w:r:(tabw2) h:c:(tabh1) line-
break:rigorous
                ENDIF
            ENDIF
            IF ((tabh1 + tabh2) > 50cm)
                IF (or = "central")
                    ATTR "Bezeichnung" x:(tabx1 + (tabw2 / 2)) y:42cm w:c:(tabw2) h:c:(tabh1)
line-break:rigorous
                ELSIF (or = "left")
                    ATTR "Bezeichnung" x:(tabx1) y:42cm w:l:(tabw2) h:c:(tabh1) line-
break:rigorous
                ELSE
                    ATTR "Bezeichnung" x:(tabx2) y:42cm w:r:(tabw2) h:c:(tabh1) line-
break:rigorous
                ENDIF
            ENDIF
        ENDIF
    ENDIF

```

```

        ENDIF
    ENDIF
    IF ((tabh1 + tabh2) > 65cm)
        IF (or = "central")
            ATTR "Bezeichnung" x:(tabx1 + (tabw2 / 2)) y:56cm w:c:(tabw2) h:c:(tabh1)
line-break:rigorous
            ELSIF (or = "left")
                ATTR "Bezeichnung" x:(tabx1) y:56cm w:l:(tabw2) h:c:(tabh1) line-
break:rigorous
            ELSE
                ATTR "Bezeichnung" x:(tabx2) y:56cm w:r:(tabw2) h:c:(tabh1) line-
break:rigorous
            ENDIF
        ENDIF
    ENDIF
    IF ((tabh1 + tabh2) > 80cm)
        IF (or = "central")
            ATTR "Bezeichnung" x:(tabx1 + (tabw2 / 2)) y:70cm w:c:(tabw2) h:c:(tabh1)
line-break:rigorous
            ELSIF (or = "left")
                ATTR "Bezeichnung" x:(tabx1) y:70cm w:l:(tabw2) h:c:(tabh1) line-
break:rigorous
            ELSE
                ATTR "Bezeichnung" x:(tabx2) y:70cm w:r:(tabw2) h:c:(tabh1) line-
break:rigorous
            ENDIF
        ENDIF
    ENDIF
    IF ((tabh1 + tabh2) > 95cm)
        IF (or = "central")
            ATTR "Bezeichnung" x:(tabx1 + (tabw2 / 2)) y:84cm w:c:(tabw2) h:c:(tabh1)
line-break:rigorous
            ELSIF (or = "left")
                ATTR "Bezeichnung" x:(tabx1) y:84cm w:l:(tabw2) h:c:(tabh1) line-
break:rigorous
            ELSE
                ATTR "Bezeichnung" x:(tabx2) y:84cm w:r:(tabw2) h:c:(tabh1) line-
break:rigorous
            ENDIF
        ENDIF
    ENDIF
    IF ((tabh1 + tabh2) > 110cm)
        IF (or = "central")
            ATTR "Bezeichnung" x:(tabx1 + (tabw2 / 2)) y:98cm w:c:(tabw2) h:c:(tabh1)
line-break:rigorous
            ELSIF (or = "left")
                ATTR "Bezeichnung" x:(tabx1) y:98cm w:l:(tabw2) h:c:(tabh1) line-
break:rigorous
            ELSE
                ATTR "Bezeichnung" x:(tabx2) y:98cm w:r:(tabw2) h:c:(tabh1) line-
break:rigorous
            ENDIF
        ENDIF
    ENDIF
    IF ((tabh1 + tabh2) > 125cm)
        IF (or = "central")
            ATTR "Bezeichnung" x:(tabx1 + (tabw2 / 2)) y:112cm w:c:(tabw2)
h:c:(tabh1) line-break:rigorous
            ELSIF (or = "left")
                ATTR "Bezeichnung" x:(tabx1) y:112cm w:l:(tabw2) h:c:(tabh1) line-
break:rigorous
            ELSE
                ATTR "Bezeichnung" x:(tabx2) y:112cm w:r:(tabw2) h:c:(tabh1) line-
break:rigorous
            ENDIF
        ENDIF
    ENDIF

```

Part IV

```
    ENDIF
    IF ((tabh1 + tabh2) > 140cm)
        IF (or = "central")
            ATTR "Bezeichnung" x:(tabx1 + (tabw2 / 2)) y:126cm w:c:(tabw2)
h:c:(tabh1) line-break:rigorous
        ELSIF (or = "left")
            ATTR "Bezeichnung" x:(tabx1) y:126cm w:l:(tabw2) h:c:(tabh1) line-
break:rigorous
        ELSE
            ATTR "Bezeichnung" x:(tabx2) y:126cm w:r:(tabw2) h:c:(tabh1) line-
break:rigorous
        ENDIF
    ENDIF
    IF ((tabh1 + tabh2) > 155cm)
        IF (or = "central")
            ATTR "Bezeichnung" x:(tabx1 + (tabw2 / 2)) y:140cm w:c:(tabw2)
h:c:(tabh1) line-break:rigorous
        ELSIF (or = "left")
            ATTR "Bezeichnung" x:(tabx1) y:140cm w:l:(tabw2) h:c:(tabh1) line-
break:rigorous
        ELSE
            ATTR "Bezeichnung" x:(tabx2) y:140cm w:r:(tabw2) h:c:(tabh1) line-
break:rigorous
        ENDIF
    ENDIF
    IF ((tabh1 + tabh2) > 170cm)
        IF (or = "central")
            ATTR "Bezeichnung" x:(tabx1 + (tabw2 / 2)) y:154cm w:c:(tabw2)
h:c:(tabh1) line-break:rigorous
        ELSIF (or = "left")
            ATTR "Bezeichnung" x:(tabx1) y:154cm w:l:(tabw2) h:c:(tabh1) line-
break:rigorous
        ELSE
            ATTR "Bezeichnung" x:(tabx2) y:154cm w:r:(tabw2) h:c:(tabh1) line-
break:rigorous
        ENDIF
    ENDIF
    ENDIF
    ENDIF
    ELSE
        IF (or = "central")
            ATTR "Working environment" text:(sInterrefText) format:"%o" x:(tabx1 + (tabw2 /
2)) y:(taby0 + tabh1 / 2) w:c:(tabw2) h:c:(tabh1) line-break:rigorous
        ELSIF (or = "left")
            ATTR "Working environment" text:(sInterrefText) format:"%o" x:(tabx1) y:(taby0
+ tabh1 / 2) w:l:(tabw2) h:c:(tabh1) line-break:rigorous
        ELSE
            ATTR "Working environment" text:(sInterrefText) format:"%o" x:(tabx2) y:(taby0
+ tabh1 / 2) w:r:(tabw2) h:c:(tabh1) line-break:rigorous
        ENDIF
        IF (w="yes")
            IF ((tabh1 + tabh2) > 20cm)
                SET cl:$b5b5b5
                FONT color:(cl) h:14pt bold
                IF (or = "central")
                    ATTR "Working environment" text:(sInterrefText) format:"%o" x:(tabx1 +
(tabw2 / 2)) y:14cm w:c:(tabw2) h:c:(tabh1) line-break:rigorous
                ELSIF (or = "left")
                    ATTR "Working environment" text:(sInterrefText) format:"%o" x:(tabx1)
y:14cm w:l:(tabw2) h:c:(tabh1) line-break:rigorous
                ELSE
                    ATTR "Working environment" text:(sInterrefText) format:"%o" x:(tabx2)
y:14cm w:r:(tabw2) h:c:(tabh1) line-break:rigorous
                ENDIF
            ENDIF
        ENDIF
    ENDIF

```

```

        ATTR "Working environment" text:(sInterrefText) format:"%o" x:(tabx2)
y:14cm w:r:(tabw2) h:c:(tabh1) line-break:rigorous
    ENDIF
ENDIF
IF ((tabh1 + tabh2) > 35cm)
    IF (or = "central")
        ATTR "Working environment" text:(sInterrefText) format:"%o" x:(tabx1 +
(tabw2 / 2)) y:28cm w:c:(tabw2) h:c:(tabh1) line-break:rigorous
    ELSIF (or = "left")
        ATTR "Working environment" text:(sInterrefText) format:"%o" x:(tabx1)
y:28cm w:l:(tabw2) h:c:(tabh1) line-break:rigorous
    ELSE
        ATTR "Working environment" text:(sInterrefText) format:"%o" x:(tabx2)
y:28cm w:r:(tabw2) h:c:(tabh1) line-break:rigorous
    ENDIF
ENDIF
IF ((tabh1 + tabh2) > 50cm)
    IF (or = "central")
        ATTR "Working environment" text:(sInterrefText) format:"%o" x:(tabx1 +
(tabw2 / 2)) y:42cm w:c:(tabw2) h:c:(tabh1) line-break:rigorous
    ELSIF (or = "left")
        ATTR "Working environment" text:(sInterrefText) format:"%o" x:(tabx1)
y:42cm w:l:(tabw2) h:c:(tabh1) line-break:rigorous
    ELSE
        ATTR "Working environment" text:(sInterrefText) format:"%o" x:(tabx2)
y:42cm w:r:(tabw2) h:c:(tabh1) line-break:rigorous
    ENDIF
ENDIF
IF ((tabh1 + tabh2) > 65cm)
    IF (or = "central")
        ATTR "Working environment" text:(sInterrefText) format:"%o" x:(tabx1 +
(tabw2 / 2)) y:56cm w:c:(tabw2) h:c:(tabh1) line-break:rigorous
    ELSIF (or = "left")
        ATTR "Working environment" text:(sInterrefText) format:"%o" x:(tabx1)
y:56cm w:l:(tabw2) h:c:(tabh1) line-break:rigorous
    ELSE
        ATTR "Working environment" text:(sInterrefText) format:"%o" x:(tabx2)
y:56cm w:r:(tabw2) h:c:(tabh1) line-break:rigorous
    ENDIF
ENDIF
IF ((tabh1 + tabh2) > 80cm)
    IF (or = "central")
        ATTR "Working environment" text:(sInterrefText) format:"%o" x:(tabx1 +
(tabw2 / 2)) y:70cm w:c:(tabw2) h:c:(tabh1) line-break:rigorous
    ELSIF (or = "left")
        ATTR "Working environment" text:(sInterrefText) format:"%o" x:(tabx1)
y:70cm w:l:(tabw2) h:c:(tabh1) line-break:rigorous
    ELSE
        ATTR "Working environment" text:(sInterrefText) format:"%o" x:(tabx2)
y:70cm w:r:(tabw2) h:c:(tabh1) line-break:rigorous
    ENDIF
ENDIF
IF ((tabh1 + tabh2) > 95cm)
    IF (or = "central")
        ATTR "Working environment" text:(sInterrefText) format:"%o" x:(tabx1 +
(tabw2 / 2)) y:84cm w:c:(tabw2) h:c:(tabh1) line-break:rigorous
    ELSIF (or = "left")
        ATTR "Working environment" text:(sInterrefText) format:"%o" x:(tabx1)
y:84cm w:l:(tabw2) h:c:(tabh1) line-break:rigorous
    ELSE

```

Part IV

```
        ATTR "Working environment" text:(sInterrefText) format:"%o" x:(tabx2)
y:84cm w:r:(tabw2) h:c:(tabh1) line-break:rigorous
    ENDIF
ENDIF
IF ((tabh1 + tabh2) > 110cm)
    IF (or = "central")
        ATTR "Working environment" text:(sInterrefText) format:"%o" x:(tabx1 +
(tabw2 / 2)) y:98cm w:c:(tabw2) h:c:(tabh1) line-break:rigorous
    ELSIF (or = "left")
        ATTR "Working environment" text:(sInterrefText) format:"%o" x:(tabx1)
y:98cm w:l:(tabw2) h:c:(tabh1) line-break:rigorous
    ELSE
        ATTR "Working environment" text:(sInterrefText) format:"%o" x:(tabx2)
y:98cm w:r:(tabw2) h:c:(tabh1) line-break:rigorous
    ENDIF
ENDIF
IF ((tabh1 + tabh2) > 125cm)
    IF (or = "central")
        ATTR "Working environment" text:(sInterrefText) format:"%o" x:(tabx1 +
(tabw2 / 2)) y:112cm w:c:(tabw2) h:c:(tabh1) line-break:rigorous
    ELSIF (or = "left")
        ATTR "Working environment" text:(sInterrefText) format:"%o" x:(tabx1)
y:112cm w:l:(tabw2) h:c:(tabh1) line-break:rigorous
    ELSE
        ATTR "Working environment" text:(sInterrefText) format:"%o" x:(tabx2)
y:112cm w:r:(tabw2) h:c:(tabh1) line-break:rigorous
    ENDIF
ENDIF
IF ((tabh1 + tabh2) > 140cm)
    IF (or = "central")
        ATTR "Working environment" text:(sInterrefText) format:"%o" x:(tabx1 +
(tabw2 / 2)) y:126cm w:c:(tabw2) h:c:(tabh1) line-break:rigorous
    ELSIF (or = "left")
        ATTR "Working environment" text:(sInterrefText) format:"%o" x:(tabx1)
y:126cm w:l:(tabw2) h:c:(tabh1) line-break:rigorous
    ELSE
        ATTR "Working environment" text:(sInterrefText) format:"%o" x:(tabx2)
y:126cm w:r:(tabw2) h:c:(tabh1) line-break:rigorous
    ENDIF
ENDIF
IF ((tabh1 + tabh2) > 155cm)
    IF (or = "central")
        ATTR "Working environment" text:(sInterrefText) format:"%o" x:(tabx1 +
(tabw2 / 2)) y:140cm w:c:(tabw2) h:c:(tabh1) line-break:rigorous
    ELSIF (or = "left")
        ATTR "Working environment" text:(sInterrefText) format:"%o" x:(tabx1)
y:140cm w:l:(tabw2) h:c:(tabh1) line-break:rigorous
    ELSE
        ATTR "Working environment" text:(sInterrefText) format:"%o" x:(tabx2)
y:140cm w:r:(tabw2) h:c:(tabh1) line-break:rigorous
    ENDIF
ENDIF
IF ((tabh1 + tabh2) > 170cm)
    IF (or = "central")
        ATTR "Working environment" text:(sInterrefText) format:"%o" x:(tabx1 +
(tabw2 / 2)) y:154cm w:c:(tabw2) h:c:(tabh1) line-break:rigorous
    ELSIF (or = "left")
        ATTR "Working environment" text:(sInterrefText) format:"%o" x:(tabx1)
y:154cm w:l:(tabw2) h:c:(tabh1) line-break:rigorous
    ELSE
```



```

        ATTR "Working environment" text:(sInterrefText) format:"%o" x:(tabx2)
y:154cm w:r:(tabw2) h:c:(tabh1) line-break:rigorous
    ENDIF
    ENDIF
    ENDIF
ENDIF
FONT
AVAL set-default:"_undefined_" sHelp:"Name"
IF (sHelp = "_undefined_")
    LINE x1:0cm y1:2.0cm x2:4.0cm y2:2.0cm
ELSE
    LINE x1:(tabx0) y1:(taby1) x2:(tabx3) y2:(taby1)
ENDIF

```

1.1.41 Relation class "Subsequent"

ADONIS BPMS BP Library 3.9:

```

GRAPHREP rounded:0.1cm
PEN w:0.05cm
EDGE
END
POLYLINE 3 x1:-.3cm y1:.1cm x2:0cm y2:0cm x3:-.3cm y3:-.1cm
MIDDLE
AVAL v:"Visualized values"
AVAL d:"Representation"
AVAL sp:"Language"
IF (sp = "System")
    IF (_uilang = "de")
        SET sp:"German"
    ELSE
        SET sp:"English"
    ENDIF
ENDIF
AVAL cl:"Font colour"
IF (cl="black")
    FONT color:black
ELSE
    FONT color:white
ENDIF
IF (d = "above/below")
    IF (v = "Denomination" OR v = "Transition probability and denomination" OR v =
"Transition condition and denomination")
        IF (sp = "English")
            ATTR "Denomination" y:.1cm w:c:3cm h:t
        ELSE
            ATTR "Bezeichnung" y:.1cm w:c:3cm h:t
        ENDIF
    ENDIF
    IF (v = "Transition condition" OR v = "Transition probability and transition con-
dition")
        IF (sp = "English")
            ATTR "Transition condition" y:.1cm w:c:3cm h:t
        ELSE
            ATTR "Info zur Übergangsbedingung" y:.1cm w:c:3cm h:t
        ENDIF
    ENDIF
    IF (v = "Transition condition and denomination")
        IF (sp = "English")

```

Part IV

```
    ATTR "Transition condition" y:-.05cm w:c:3cm h:b
ELSE
    ATTR "Info zur Übergangsbedingung" y:-.05cm w:c:3cm h:b
ENDIF
ENDIF
IF (v = "Transition probability" OR v = "Transition probability and transition
condition" OR v = "Transition probability and denomination")
    ATTR "Transition probability" y:-.05cm w:c:3cm h:b
ENDIF
ENDIF
IF (d = "left/right")
    IF (v = "Denomination" OR v = "Transition probability and denomination" OR v =
"Transition condition und Denomination")
        IF (sp = "English")
            ATTR "Denomination" x:0.15cm w:l:3cm h:c
        ELSE
            ATTR "Bezeichnung" x:0.15cm w:l:3cm h:c
        ENDIF
    ENDIF
    IF (v = "Transition condition" OR v = "Transition probability and transition con-
dition")
        IF (sp = "English")
            ATTR "Transition condition" x:0.15cm w:l:3cm h:c
        ELSE
            ATTR "Info zur Übergangsbedingung" x:0.15cm w:l:3cm h:c
        ENDIF
    ENDIF
    IF (v = "Transition condition and denomination")
        IF (sp = "English")
            ATTR "Transition condition" x:-.10cm w:r:3cm h:c
        ELSE
            ATTR "Info zur Übergangsbedingung" x:-.10cm w:r:3cm h:c
        ENDIF
    ENDIF
    IF (v = "Transition probability" OR v = "Transition probability and transition
condition" OR v = "Transition probability and denomination")
        ATTR "Transition probability" x:-.10cm w:r:3cm h:c
    ENDIF
ENDIF
ENDIF
```

1.1.42 Relation class "Sets variable"

ADONIS BPMS BP Library 3.9:

```
GRAPHREP rounded:0.1cm
PEN style:dot
EDGE
PEN style:solid
START
LINE x1:0cm y1:.1cm x2:0cm y2:-.1cm
END
LINE x1:-.3cm y1:.1cm x2:0cm y2:0cm
LINE x1:-.3cm y1:-.1cm x2:0cm y2:0cm
```

1.1.43 Relation class "Sets"

ADONIS BPMS BP Library 3.9:

```

GRAPHREP rounded:0.1cm
PEN style:dot
EDGE
PEN style:solid
START
LINE x1:0cm y1:.1cm x2:0cm y2:-.1cm
END
FILL color:black
POLYGON 3 x1:-.3cm y1:.1cm x2:0cm y2:0cm x3:-.3cm y3:-.1cm

```

1.1.44 Relation class "Parameter"

ADONIS BPMS BP Library 3.9:

```

GRAPHREP
START
FILL color:black
ELLIPSE x:-.1cm rx:.1cm ry:.1cm
END
LINE x1:-.3cm y1:.1cm x2:0cm y2:0cm
LINE x1:-.3cm y1:-.1cm x2:0cm y2:0cm
MIDDLE
ATTR "Index" y:.2cm w:c:2.8cm h:t

```

1.1.45 Relation class "Call parameter"

ADONIS BPMS BP Library 3.9:

```

GRAPHREP
START
FILL color:black
ELLIPSE x:-.1cm rx:.1cm ry:.1cm
END
FILL color:black
POLYGON 3 x1:-.3cm y1:.1cm x2:0cm y2:0cm x3:-.3cm y3:-.1cm
MIDDLE
ATTR "Index" y:.2cm w:c:2.8cm h:t

```

1.1.46 Relation class "Uses"

ADONIS BPMS BP Library 3.9:

```

GRAPHREP
START
FILL color:black
ELLIPSE x:-.1cm rx:.1cm ry:.1cm
END
FILL color:black
ELLIPSE x:-.1cm rx:.1cm ry:.1cm

```

1.1.47 Relation class "communicates"

ADONIS BPMS BP Library 3.9:

Part IV

```
GRAPHREP
SHADOW mode:off
PEN w:0.02cm
EDGE
MIDDLE
AVAL sp:"Language"
IF (sp = "System")
  IF (_uilang = "en")
    SET sp:"English"
  ELSE
    SET sp:"German"
  ENDIF
ENDIF
IF (sp = "English")
  ATTR "Name" y:0.00cm w:c:2.00cm h:b
ELSE
  ATTR "Bezeichnung" y:0.00cm w:c:2.00cm h:b
ENDIF
```

1.1.48 Relation class "Value flow"

ADONIS BPMS BP Library 3.9:

```
GRAPHREP
AVAL sType:"Type"
AVAL sp:"Language"
IF (sp = "System")
  IF (_uilang = "en")
    SET sp:"English"
  ELSE
    SET sp:"German"
  ENDIF
ENDIF
IF (sType = "Material flow")
  SET sText:("M")
ELSIF (sType = "Contorl flow")
  IF (sp = "English")
    SET sText:("K")
  ELSE
    SET sText:("K")
  ENDIF
ELSE
  SET sText:("i")
ENDIF
AVAL mono:"_exprMonochrome_"
IF (mono = "yes")
  SET bMono:1
ELSE
  SET bMono:0
ENDIF
START
FILL color:black
POLYGON 3 x1:-.3cm y1:.1cm x2:0cm y2:0cm x3:-.3cm y3:-.1cm
END
FILL color:black
POLYGON 3 x1:-.3cm y1:.1cm x2:0cm y2:0cm x3:-.3cm y3:-.1cm
MIDDLE
IF (bMono)
  FILL color:white
```

```

    ELLIPSE x:0cm y:0cm rx:.17cm ry:.17cm
    FONT "Times New Roman" color:black h:8pt bold
    TEXT (sText) x:0.0cm y:0.01cm w:c h:c
ELSE
    FILL color:blue
    ELLIPSE x:0cm y:0cm rx:.17cm ry:.17cm
    FONT "Times New Roman" color:white h:8pt bold
    TEXT (sText) x:0.0cm y:0.01cm w:c h:c
ENDIF

```

1.1.49 Relation class "Generalisation"

ADONIS BPMS BP Library 3.9:

```

GRAPHREP
SHADOW mode:off
PEN w:0.02cm
EDGE
PEN style:solid w:0.02cm
MIDDLE
AVAL sp:"Language"
IF (sp = "System")
    IF (_uilang = "de")
        SET sp:"German"
    ELSE
        SET sp:"English"
    ENDIF
ENDIF
IF (sp = "English")
    ATTR "Name" x:0.00cm y:0.00cm w:c:2.00cm h:b
ELSE
    ATTR "Bezeichnung" x:0.00cm y:0.00cm w:c:2.00cm h:b
ENDIF
END
FILL color:white
POLYGON 3 x1:-.4cm y1:.2cm x2:0cm y2:0cm x3:-.4cm y3:-.2cm

```

1.1.50 Relation class "contains"

ADONIS BPMS BP Library 3.9:

```

GRAPHREP
SHADOW mode:off
PEN style:dash w:0.02cm
EDGE
PEN style:solid w:0.02cm
MIDDLE
AVAL sp:"Language"
IF (sp = "System")
    IF (_uilang = "en")
        SET sp:"English"
    ELSE
        SET sp:"German"
    ENDIF
ENDIF
IF (sp = "English")
    ATTR "Name" x:0.00cm y:0.00cm w:c:2.00cm h:b
ELSE

```

Part IV

```
ATTR "Bezeichnung" x:0.00cm y:0.00cm w:c:2.00cm h:b
ENDIF
AVAL set-default:"small" s:"State"
IF (s = "small")
  FONT h:8.0pt
  TEXT "includes" x:0.00cm y:0.00cm w:c:2.00cm h:t
ELSE
  TEXT "<<includes>>" x:0.00cm y:0.00cm w:c:2.00cm h:t
ENDIF
END
FILL color:white
POLYGON 3 x1:-.33cm y1:-.11cm x2:0.0cm y2:0.0cm x3:-.33cm y3:0.11cm
```

1.1.51 Relation class "extends"

ADONIS BPMS BP Library 3.9:

```
GRAPHREP
SHADOW mode:off
PEN w:0.02cm
EDGE
MIDDLE
AVAL sp:"Language"
IF (sp = "System")
  IF (_uilang = "en")
    SET sp:"English"
  ELSE
    SET sp:"German"
  ENDIF
ENDIF
IF (sp = "English")
  ATTR "Name" x:0.00cm y:0.00cm w:c:2.00cm h:b
ELSE
  ATTR "Bezeichnung" x:0.00cm y:0.00cm w:c:2.00cm h:b
ENDIF
AVAL set-default:"small" s:"State"
IF (s = "small")
  FONT h:8.0pt
  TEXT "extends" x:0.00cm y:0.00cm w:c:2.00cm h:t
ELSE
  TEXT "<<extends>>" x:0.00cm y:0.00cm w:c:2.00cm h:t
ENDIF
END
FILL color:black
POLYGON 3 x1:-.33cm y1:-.11cm x2:0.0cm y2:0.0cm x3:-.33cm y3:0.11cm
```

1.1.52 Relation class "uses"

ADONIS BPMS BP Library 3.9:

```
GRAPHREP
SHADOW mode:off
PEN style:solid w:0.02cm
EDGE
MIDDLE
AVAL sp:"Language"
IF (sp = "System")
  IF (_uilang = "en")
```

```

    SET sp:"English"
ELSE
    SET sp:"German"
ENDIF
ENDIF
IF (sp = "English")
    ATTR "Name" x:0.00cm y:0.00cm w:c:2.00cm h:b
ELSE
    ATTR "Bezeichnung" x:0.00cm y:0.00cm w:c:2.00cm h:b
ENDIF
AVAL set-default:"small" s:"State"
IF (s = "small")
    FONT h:8.0pt
    TEXT "uses" x:0.00cm y:0.00cm w:c:2.00cm h:t
ELSE
    TEXT "<<uses>>" x:0.00cm y:0.00cm w:c:2.00cm h:t
ENDIF
END
FILL color:white
POLYGON 3 x1:-.33cm y1:-.11cm x2:0.0cm y2:0.0cm x3:-.33cm y3:0.11cm

```

1.1.53 Relation class "Has process"

ADONIS BPMS BP Library 3.9:

```

GRAPHREP
PEN w:0.025cm
EDGE
START
LINE x1:0.00cm y1:-.14cm x2:0.00cm y2:0.14cm
END
LINE x1:-.3cm y1:-.1cm x2:0.00cm y2:0.00cm
LINE x1:-.3cm y1:0.1cm x2:0.00cm y2:0.00cm
MIDDLE
AVAL d:"Representation"
AVAL sp:"Language"
IF (sp = "System")
    IF (_uilang = "en")
        SET sp:"English"
    ELSE
        SET sp:"German"
    ENDIF
ENDIF
AVAL cl:"Fontcolor"
IF (cl="black")
    FONT color:black
ELSE
    FONT color:white
ENDIF
IF (d = "above/below")
    IF (sp = "English")
        ATTR "Name" y:.1cm w:c:3cm h:t
    ELSE
        ATTR "Bezeichnung" y:.1cm w:c:3cm h:t
    ENDIF
ENDIF
IF (d = "left/right")
    IF (sp = "English")
        ATTR "Name" x:0.15cm w:l:3cm h:c
    
```

Part IV

```
ELSE
  ATTR "Bezeichnung" x:0.15cm w:l:3cm h:c
ENDIF
ENDIF
```

1.1.54 Relation class "has Subdocument"

ADONIS BPMS BP Library 3.9:

```
GRAPHREP
SHADOW mode:off
PEN w:0.02cm
EDGE
  START
  FILL color:white
  ELLIPSE x:-0.1cm y:0cm rx:0.1cm ry:0.1cm
  END
  FILL color:black
  POLYGON 3 x1:-0.28cm y1:0.11cm x2:0cm y2:0cm
  x3:-0.28cm y3:-0.11cm
```

1.1.55 Relation class "has "

ADONIS BPMS BP Library 3.9:

```
GRAPHREP
SHADOW mode:off
AVAL cl:"Fontcolor"
AVAL str_display:"Representation"
AVAL sp:"Language"
IF (sp = "System")
  IF (_uilang = "de")
    SET sp:"German"
  ELSE
    SET sp:"English"
  ENDIF
ENDIF
IF (sp = "German")
  AVAL str_term:"Bezeichnung"
ELSE
  AVAL str_term:"Name"
ENDIF
#SET str_term:"Mein Term"
IF (cl="black")
  FONT color:black
ELSE
  FONT color:white
ENDIF
PEN w:0.02cm
EDGE
MIDDLE
  IF (str_display = "right")
    TEXT (str_term) x:0.05cm w:l h:c
  ELSE
    TEXT (str_term) w:c h:t
  ENDIF
END
LINE x1:-.3cm y1:-.1cm x2:0.00cm y2:0.00cm
```

LINE x1:-.3cm y1:0.1cm x2:0.00cm y2:0.00cm

1.1.56 Relation class "has"

ADONIS BPMS BP Library 3.9:

```

GRAPHREP
SHADOW mode:off
AVAL cl:"Fontcolor"
AVAL str_display:"Representation"
AVAL sp:"Language"
IF (sp = "System")
  IF (_uilang = "en")
    SET sp:"English"
  ELSE
    SET sp:"German"
  ENDIF
ENDIF
IF (sp = "English")
  AVAL str_term:"Name"
ELSE
  AVAL str_term:"Bezeichnung"
ENDIF
#SET str_term:"Mein Term"
IF (cl="black")
  FONT color:black
ELSE
  FONT color:white
ENDIF
PEN w:0.02cm
EDGE
MIDDLE
  IF (str_display = "right")
    TEXT (str_term) x:0.05cm w:l h:c
  ELSE
    TEXT (str_term) w:c h:t
  ENDIF
END
LINE x1:-.3cm y1:-.1cm x2:0.00cm y2:0.00cm
LINE x1:-.3cm y1:0.1cm x2:0.00cm y2:0.00cm

```

1.1.57 Relation class "uses "

ADONIS BPMS BP Library 3.9:

```

GRAPHREP
SHADOW mode:off
AVAL cl:"Fontcolor"
AVAL str_display:"Representation"
AVAL sp:"Language"
IF (sp = "System")
  IF (_uilang = "de")
    SET sp:"German"
  ELSE
    SET sp:"English"
  ENDIF
ENDIF
IF (sp = "English")

```

Part IV

```
AVAL str_term:"Name"
ELSE
  AVAL str_term:"Bezeichnung"
ENDIF
#SET str_term:"Mein Term"
IF (cl="black")
  FONT color:black
ELSE
  FONT color:white
ENDIF
PEN w:0.02cm style:dash
EDGE
MIDDLE
  IF (str_display = "right")
    TEXT (str_term) x:0.05cm w:l h:c
  ELSE
    TEXT (str_term) w:c h:t
  ENDIF
END
LINE x1:-.3cm y1:-.1cm x2:0.00cm y2:0.00cm
LINE x1:-.3cm y1:0.1cm x2:0.00cm y2:0.00cm
```

1.1.58 Relation class "Is dependent on"

ADONIS BPMS BP Library 3.9:

```
GRAPHREP
SHADOW mode:off
AVAL cl:"Fontcolor"
AVAL str_display:"Representation"
AVAL sp:"Language"
IF (sp = "System")
  IF (_uilang = "de")
    SET sp:"German"
  ELSE
    SET sp:"English"
  ENDIF
ENDIF
IF (sp = "German")
  AVAL str_term:"Bezeichnung"
ELSE
  AVAL str_term:"Name"
ENDIF
#SET str_term:"Mein Term"
IF (cl="black")
  FONT color:black
ELSE
  FONT color:white
ENDIF
PEN w:0.02cm
EDGE
MIDDLE
  IF (str_display = "right")
    TEXT (str_term) x:0.05cm w:l h:c
  ELSE
    TEXT (str_term) w:c h:t
  ENDIF
END
#LINE x1:-.3cm y1:-.1cm x2:0.00cm y2:0.00cm
```

```
#LINE x1:-.3cm y1:0.1cm x2:0.00cm y2:0.00cm
```

1.1.59 Relation class "Owns"

ADONIS BPMS BP Library 3.9:

```
GRAPHREP
AVAL mono: "_exprMonochrome_"
IF (mono = "yes")
  SET bMono:1
ELSE
  SET bMono:0
ENDIF
IF (bMono)
  FILL color:white
ELSE
  FILL color:dodgerblue
ENDIF
SHADOW mode:off
PEN w:0.02cm
EDGE
  START
  ELLIPSE x:-0.05cm y:0cm rx:0.05cm ry:0.05cm
  END
  POLYGON 3 x1:-0.2cm y1:0.11cm x2:0cm y2:0cm
  x3:-0.2cm y3:-0.11cm
```

1.1.60 Relation class "has Note"

ADONIS BPMS BP Library 3.9:

```
GRAPHREP
PEN w:0.02cm color:lightyellow outline style:dot
EDGE
```

1.1.61 Relation class "has Cross-reference"

ADONIS BPMS BP Library 3.9:

```
GRAPHREP rounded:0.05cm
FILL color:lightgray
SHADOW mode:off
PEN w:0.02cm color:$727272
EDGE
  START
  END
  POLYGON 3 x1:-0.2cm y1:0.11cm x2:0cm y2:0cm
  x3:-0.2cm y3:-0.11cm
```

1.1.62 Relation class "Is subordinated"

ADONIS BPMS WE Library 3.9:

Part IV

```
GRAPHREP rounded:0.1cm layer:-1
AVAL str_display:"Representation"
PEN w:0.03cm
EDGE
END
IF (str_display = "without arrow")
ELSE
LINE x1:-.3cm y1:.1cm x2:0cm y2:0cm
LINE x1:-.3cm y1:-.1cm x2:0cm y2:0cm
ENDIF
```

1.1.63 Relation class "has Resource"

ADONIS BPMS WE Library 3.9:

```
GRAPHREP rounded:0.1cm
FILL color:dimgray
START
POLYGON 4 x1:-.16cm y1:-.08cm x2:0cm y2:-.08cm x3:0cm y3:.08cm x4:-.16cm y4:.08cm
END
POLYGON 4 x1:-.16cm y1:-.08cm x2:0cm y2:-.08cm x3:0cm y3:.08cm x4:-.16cm y4:.08cm
```

1.1.64 Relation class "has position"

ADONIS BPMS WE Library 3.9:

```
GRAPHREP
layer:-2
SHADOW mode:off
PEN color:darkgray w:0.04cm
EDGE
```

1.1.65 Relation class "Belongs to"

ADONIS BPMS WE Library 3.9:

```
GRAPHREP rounded:0.1cm
PEN w:0.03cm
EDGE
FILL color:black
START
ELLIPSE x:-.1cm rx:.1cm ry:.1cm
END
POLYGON 3 x1:-.3cm y1:.1cm x2:0cm y2:0cm x3:-.3cm y3:-.1cm
```

1.1.66 Relation class "Is manager"

ADONIS BPMS WE Library 3.9:

```
GRAPHREP rounded:0.1cm
PEN w:0.03cm
EDGE
START
LINE x1:0cm y1:-.1cm x2:0cm y2:.1cm
```

```
LINE x1:-.1cm y1:-.05cm x2:-.1cm y2:.05cm
END
LINE x1:-.3cm y1:.1cm x2:0cm y2:0cm
LINE x1:-.3cm y1:-.1cm x2:0cm y2:0cm
```

1.1.67 Relation class "Has role"

ADONIS BPMS WE Library 3.9:

```
GRAPHREP rounded:0.1cm
PEN style:dot
EDGE
PEN style:solid
START
LINE x1:-.18cm y1:-.1cm y2:-.1cm
LINE x1:-.18cm x2:0cm
LINE x1:-.18cm y1:.1cm y2:.1cm
END
LINE x1:-.3cm y1:.1cm x2:0cm y2:0cm
LINE x1:-.3cm x2:0cm
LINE x1:-.3cm y1:-.1cm x2:0cm y2:0cm
```

1.1.68 Relation class "Uses resource"

ADONIS BPMS WE Library 3.9:

```
GRAPHREP rounded:0.1cm
FILL color:dimgray
START
ELLIPSE x:-.1cm rx:.1cm ry:.1cm
END
ELLIPSE x:-.1cm rx:.1cm ry:.1cm
```

1.1.69 Relation class "Is charged to"

ADONIS BPMS WE Library 3.9:

```
GRAPHREP rounded:0.1cm
PEN w:.04cm
START
LINE x1:-.15cm x2:0cm
LINE x1:-.075cm y1:-.075cm x2:-.075cm y2:.075cm
PEN w:0.01cm
END
LINE x1:-.2cm y1:.1cm x2:0cm y2:0cm
LINE x1:-.2cm y1:-.1cm x2:0cm y2:0cm
LINE x1:-.2cm x2:0cm
```

1.1.70 Relation class "Is cost center manager"

ADONIS BPMS WE Library 3.9:

```
GRAPHREP rounded:0.1cm
PEN w:.04cm
```

Part IV

```
START
LINE x1:-.2cm x2:0cm
LINE x1:-.1cm y1:-.075cm x2:-.1cm y2:.075cm
LINE y1:-.1cm y2:.1cm
PEN w:.01cm
END
LINE x1:-.2cm y1:.1cm x2:0cm y2:0cm
LINE x1:-.2cm y1:-.1cm x2:0cm y2:0cm
LINE x1:-.2cm x2:0cm
```

1.1.71 Relation class "has Note"

ADONIS BPMS WE Library 3.9:

```
GRAPHREP
PEN w:0.02cm color:lightyellow outline style:dot
EDGE
```

1.2 AttrRep

The class attribute "AttrRep" is defined for the following **Classes of the ADONIS BPMS BP Library 3.9:**



actor (see chap. 1.2.1, p. 406)



use case (see chap. 1.2.2, p. 406)



system boundary (see chap. 1.2.3, p. 407)



Trigger (see chap. 1.2.4, p. 408)



Process start (see chap. 1.2.5, p. 408)



Subprocess (see chap. 1.2.6, p. 410)



Activity (see chap. 1.2.7, p. 411)



Decision (see chap. 1.2.8, p. 415)



Parallellity (see chap. 1.2.9, p. 416)



Merging (see chap. 1.2.10, p. 417)



End (see chap. 1.2.11, p. 417)



Variable (see chap. 1.2.12, p. 418)



Random generator (see chap. 1.2.13, p. 418)



Resource (see chap. 1.2.14, p. 419)



Process (see chap. 1.2.15, p. 420)



Performance indicator overview (see chap. 1.2.16, p. 421)



Performance indicator (see chap. 1.2.17, p. 422)













Document (see chap. 1.2.18, p. 424)

















Note (see chap. 1.2.19, p. 425)











Aggregation (see chap. 1.2.20, p. 425)

-  **Swimlane (horizontal) (see chap. 1.2.21, p. 426)**
-  **Swimlane (vertical) (see chap. 1.2.22, p. 427)**
-  **External partner (see chap. 1.2.23, p. 428)**
-  **Product (see chap. 1.2.24, p. 428)**
-  **Product component (see chap. 1.2.25, p. 429)**
-  **Application (see chap. 1.2.26, p. 430)**
-  **Service (see chap. 1.2.27, p. 431)**
-  **Performance (see chap. 1.2.28, p. 432)**
-  **Infrastructure element (see chap. 1.2.29, p. 433)**
-  **Cross-reference (see chap. 1.2.30, p. 433)**

The class attribute "AttrRep" is defined for the following **Relation classes of the ADONIS BPMS BP Library 3.9:**

-  **Subsequent (see chap. 1.2.41, p. 443)**
-  **Parameter (see chap. 1.2.42, p. 444)**
-  **Call parameter (see chap. 1.2.43, p. 444)**
-  **communicates (see chap. 1.2.44, p. 444)**
-  **Value flow (see chap. 1.2.45, p. 445)**
-  **Generalisation (see chap. 1.2.46, p. 445)**
-  **contains (see chap. 1.2.47, p. 446)**
-  **extends (see chap. 1.2.48, p. 446)**
-  **uses (see chap. 1.2.49, p. 447)**
-  **Has process (see chap. 1.2.50, p. 448)**
-  **has (see chap. 1.2.51, p. 448)**
-  **has (see chap. 1.2.52, p. 449)**
-  **uses (see chap. 1.2.53, p. 449)**
-  **Is dependent on (see chap. 1.2.54, p. 450)**

The class attribute "AttrRep" is defined for the following **Classes of the ADONIS BPMS WE Library 3.9:**

-  **Organizational unit (see chap. 1.2.31, p. 434)**
-  **Performer (see chap. 1.2.32, p. 436)**
-  **Role (see chap. 1.2.33, p. 437)**
-  **Position (see chap. 1.2.34, p. 438)**
-  **Resource (see chap. 1.2.35, p. 438)**
-  **Cost center (see chap. 1.2.36, p. 439)**
-  **Aggregation (see chap. 1.2.37, p. 440)**
-  **Note (see chap. 1.2.38, p. 441)**

Part IV

☐ **Swimlane (horizontal)** (see chap. 1.2.39, p. 441)

☐ **Swimlane (vertical)** (see chap. 1.2.40, p. 442)

The class attribute "AttrRep" is defined for the following **Relation classes of the ADONIS BPMS WE Library 3.9:**

→ **Is subordinated** (see chap. 1.2.55, p. 450)

1.2.1 Class "actor"

ADONIS BPMS BP Library 3.9:

```
NOTEBOOK
#-----
LANG "en"
#-----
CHAPTER "Description"
ATTR "Name"
ATTR "Referenced organizational unit"
ATTR "Description" lines:5
ATTR "Comment" lines:5
ATTR "Open questions" lines:5
CHAPTER "Representation"
ATTR "Color" dialog:color
CHAPTER "Deutsch"
GROUP "Akteur"
ATTR "Bezeichnung"
ATTR "Beschreibung" lines:5
ATTR "Kommentar" lines:5
ENDGROUP
#-----
LANG "de"
#-----
CHAPTER "Beschreibung (deutsch)"
GROUP "Akteur"
ATTR "Bezeichnung"
ATTR "Beschreibung" lines:5
ATTR "Kommentar" lines:5
ENDGROUP
CHAPTER "Beschreibung"
ATTR "Name"
ATTR "Referenced organizational unit"
ATTR "Description" lines:5
ATTR "Comment" lines:5
ATTR "Open questions" lines:5
CHAPTER "Darstellung"
ATTR "Color" dialog:color
```

1.2.2 Class "use case"

ADONIS BPMS BP Library 3.9:

```
NOTEBOOK
#-----
LANG "en"
#-----
CHAPTER "Description"
```



```

ATTR "Name"
ATTR "Description" lines:5
ATTR "Comment" lines:5
ATTR "External documentation"
ATTR "Details"
ATTR "Open questions" lines:5
CHAPTER "Deutsch"
GROUP "Anwendungsfall"
ATTR "Bezeichnung"
ATTR "Beschreibung" lines:5
ATTR "Kommentar" lines:5
ENDGROUP
#-----
LANG "de"
#-----
CHAPTER "Beschreibung (deutsch)"
GROUP "Anwendungsfall"
ATTR "Bezeichnung"
ATTR "Beschreibung" lines:5
ATTR "Kommentar" lines:5
ENDGROUP
CHAPTER "Beschreibung"
ATTR "Name"
ATTR "Description" lines:5
ATTR "Comment" lines:5
ATTR "External documentation"
ATTR "Details"
ATTR "Open questions" lines:5

```

1.2.3 Class "system boundary"

ADONIS BPMS BP Library 3.9:

```

NOTEBOOK
#-----
LANG "en"
#-----
CHAPTER "Description"
ATTR "Name"
ATTR "Representation"
ATTR "Description" lines:5
ATTR "Comment" lines:5
ATTR "Open questions" lines:5
CHAPTER "Deutsch"
GROUP "Systemgrenze"
ATTR "Bezeichnung"
ATTR "Beschreibung" lines:5
ATTR "Kommentar" lines:5
ENDGROUP
#-----
LANG "de"
#-----
CHAPTER "Beschreibung (deutsch)"
GROUP "Systemgrenze"
ATTR "Bezeichnung"
ATTR "Beschreibung" lines:5
ATTR "Kommentar" lines:5
ENDGROUP
CHAPTER "Beschreibung"

```

Part IV

```
ATTR "Name"  
ATTR "Representation"  
ATTR "Description" lines:5  
ATTR "Comment" lines:5  
ATTR "Open questions" lines:5
```

1.2.4 Class "Trigger"

ADONIS BPMS BP Library 3.9:

```
NOTEBOOK  
#-----  
LANG "en"  
#-----  
CHAPTER "Description"  
ATTR "Name"  
ATTR "Referenced trigger"  
ATTR "Description"  
ATTR "Comment"  
ATTR "External documentation"  
ATTR "Referenced documents"  
ATTR "Open questions"  
ATTR "Referenced IT system elements"  
ATTR "Visualise referenced IT system elements" ctrltype:check  
CHAPTER "Deutsch"  
ATTR "Bezeichnung"  
ATTR "Beschreibung"  
ATTR "Kommentar"  
#-----  
LANG "de"  
#-----  
CHAPTER "Beschreibung (deutsch)"  
ATTR "Bezeichnung"  
ATTR "Beschreibung"  
ATTR "Kommentar"  
CHAPTER "Beschreibung"  
ATTR "Name"  
ATTR "Referenced trigger"  
ATTR "Description"  
ATTR "Comment"  
ATTR "External documentation"  
ATTR "Referenced documents"  
ATTR "Open questions"  
ATTR "Referenced IT system elements"  
ATTR "Visualise referenced IT system elements" ctrltype:check
```

1.2.5 Class "Process start"

ADONIS BPMS BP Library 3.9:

```
NOTEBOOK  
#-----  
LANG "en"  
#-----  
CHAPTER "Description"  
ATTR "Name"  
ATTR "Order"  
ATTR "Description" lines:5
```

```

ATTR "Comment" lines:5
ATTR "Trigger" lines:3
ATTR "Result" lines:3
ATTR "Process responsibility"
ATTR "Open questions" lines:5
CHAPTER "Documents"
ATTR "Input"
ATTR "Output"
ATTR "Referenced documents" lines:5
ATTR "External documentation"
CHAPTER "System"
ATTR "Referenced IT system elements"
CHAPTER "Products"
ATTR "Referenced products"
CHAPTER "Simulation data"
GROUP "Capacity analysis"
ATTR "Quantity"
ATTR "Time period" ctrltype:radio
ENDGROUP
GROUP "Workload analysis"
ATTR "Process calendar" dialog:processstart-calendar
ATTR "Tolerance waiting time"
ATTR "Abandon after tolerance waiting time" ctrltype:check checked-value:"yes" un-
checked-value:"no"
ENDGROUP
GROUP "Process cost analysis"
ATTR "Cost driver"
ATTR "Cost driver quantity"
ENDGROUP
CHAPTER "Simulation results"
GROUP "Times"
ATTR "Aggregated cycle time" write-protected
ATTR "Aggregated execution time" write-protected
ATTR "Aggregated waiting time" write-protected
ATTR "Aggregated resting time" write-protected
ATTR "Aggregated transport time" write-protected
ENDGROUP
GROUP "Costs"
ATTR "Aggregated costs" write-protected
ATTR "Aggregated personnel costs" write-protected
ENDGROUP
ATTR "Info on results" write-protected lines:5
CHAPTER "Deutsch"
GROUP "Prozeßstart Charakteristiska"
ATTR "Bezeichnung"
ATTR "Beschreibung" lines:5
ATTR "Kommentar" lines:5
ENDGROUP
#-----
LANG "de"
#-----
CHAPTER "Beschreibung (deutsch)"
GROUP "Prozeßstart"
ATTR "Bezeichnung"
ATTR "Beschreibung" lines:5
ATTR "Kommentar" lines:5
ENDGROUP
CHAPTER "Beschreibung"
ATTR "Name"
ATTR "Order"
ATTR "Description" lines:5

```

Part IV

```
ATTR "Comment" lines:5
ATTR "Trigger" lines:3
ATTR "Result" lines:3
ATTR "Process responsibility"
ATTR "Open questions" lines:5
CHAPTER "Documents"
ATTR "Input"
ATTR "Output"
ATTR "Referenced documents" lines:5
ATTR "External documentation"
CHAPTER "Systems"
ATTR "Referenced IT system elements"
CHAPTER "Products"
ATTR "Referenced products"
CHAPTER "Simulation data"
GROUP "Capacity analysis"
ATTR "Quantity"
ATTR "Time period" ctrltype:radio
ENDGROUP
GROUP "Workload analysis"
ATTR "Process calendar" dialog:processstart-calendar
ATTR "Tolerance waiting time"
ATTR "Abandon after tolerance waiting time" ctrltype:check checked-value:"yes" un-
checked-value:"no"
ENDGROUP
GROUP "Process cost analysis"
ATTR "Cost driver"
ATTR "Cost driver quantity"
ENDGROUP
CHAPTER "Simulation results"
GROUP "Times"
ATTR "Aggregated cycle time" write-protected
ATTR "Aggregated execution time" write-protected
ATTR "Aggregated waiting time" write-protected
ATTR "Aggregated resting time" write-protected
ATTR "Aggregated transport time" write-protected
ENDGROUP
GROUP "Costs"
ATTR "Aggregated costs" write-protected
ATTR "Aggregated personnel costs" write-protected
ENDGROUP
ATTR "Info on results" write-protected lines:5
```

1.2.6 Class "Subprocess"

ADONIS BPMS BP Library 3.9:

```
NOTEBOOK
#-----
LANG "en"
#-----
CHAPTER "Description"
GROUP "Representation"
ATTR "Name"
ATTR "Referenced subprocess"
ATTR "Display name and reference" ctrltype:check checked-value:"yes" unchecked-
value:"no"
ENDGROUP
ATTR "Order"
```

```

ATTR "Description" lines:5
ATTR "Comment" lines:5
ATTR "Open questions" lines:5
CHAPTER "Working environment"
ATTR "Performer" dialog:actor lines:3
CHAPTER "Simulation results"
GROUP "Times"
ATTR "Aggregated execution time" write-protected
ATTR "Aggregated waiting time" write-protected
ATTR "Aggregated resting time" write-protected
ATTR "Aggregated transport time" write-protected
ENDGROUP
GROUP "Costs"
ATTR "Aggregated costs" write-protected
CHAPTER "Deutsch"
GROUP "Prozeßaufruf"
ATTR "Bezeichnung"
ATTR "Beschreibung" lines:5
ATTR "Kommentar" lines:5
ENDGROUP
#-----
LANG "de"
#-----
CHAPTER "Beschreibung (deutsch)"
GROUP "Prozeßaufruf"
ATTR "Bezeichnung"
ATTR "Beschreibung" lines:5
ATTR "Kommentar" lines:5
ENDGROUP
CHAPTER "Beschreibung"
GROUP "Representation"
ATTR "Name"
ATTR "Referenced subprocess"
ATTR "Display name and reference" ctrltype:check checked-value:"yes" unchecked-
value:"no"
ENDGROUP
ATTR "Order"
ATTR "Description" lines:5
ATTR "Comment" lines:5
ATTR "Open questions" lines:5
CHAPTER "Arbeitsumgebung"
ATTR "Performer" dialog:actor lines:3
CHAPTER "Auswertungsergebnisse"
GROUP "Times"
ATTR "Aggregated execution time" write-protected
ATTR "Aggregated waiting time" write-protected
ATTR "Aggregated resting time" write-protected
ATTR "Aggregated transport time" write-protected
ENDGROUP
GROUP "Costs"
ATTR "Aggregated costs" write-protected

```

1.2.7 Class "Activity"

ADONIS BPMS BP Library 3.9:

```

NOTEBOOK
#-----
LANG "en"

```

Part IV

```
#-----
#-----
CHAPTER "Description"
#-----
ATTR "Name"
ATTR "Order"
ATTR "Description" lines:5
ATTR "Comment" lines:5
GROUP "Responsible role"
ATTR "Responsible role"
ATTR "Display responsible role" ctrltype:check checked-value:"Yes" unchecked-
value:"No"
ENDGROUP
ATTR "Classification"
ATTR "Open questions" lines:5
#-----
CHAPTER "RACI/DEMI"
#-----
ATTR "Responsible for execution"
ATTR "Accountable for approving results"
ATTR "Cooperation/participation" lines:3
ATTR "To inform" lines:3
#-----
CHAPTER "Documents"
#-----
ATTR "Input"
ATTR "Output"
ATTR "Referenced documents"
ATTR "External documentation"
#-----
CHAPTER "Systems"
#-----
ATTR "Referenced IT system elements"
ATTR "Visualise referenced IT system elements" ctrltype:check
ATTR "Referenced use cases"
#-----
CHAPTER "Products"
#-----
ATTR "Referenced products"
#-----
CHAPTER "Times/Costs"
#-----
GROUP "Activity times"
ATTR "Execution time"
ATTR "Waiting time"
ATTR "Resting time"
ATTR "Transport time"
ENDGROUP
GROUP "Activity costs"
ATTR "Costs"
ENDGROUP
GROUP "Process cost analysis"
ATTR "EDP transaction costs"
ATTR "EDP batch costs"
ATTR "Printing costs"
ATTR "Postal costs"
ENDGROUP
#-----
CHAPTER "Working environment"
#-----
GROUP "Simulation"
```

```

ATTR "Performer" dialog:actor lines:3
ATTR "Continuous execution" ctrltype:check checked-value:"yes" unchecked-value:"no"
ATTR "Execution interruptable" ctrltype:check checked-value:"yes" unchecked-
value:"no"
ATTR "Task stack"
ATTR "Done by"
ENDGROUP
#-----
CHAPTER "Other simulation data"
#-----
GROUP "Cooperation"
ATTR "Cooperative" ctrltype:check checked-value:"yes" unchecked-value:"no"
ATTR "Cooperation mode" ctrltype:radio
ATTR "Average number of participants"
ATTR "Min. quota of presence"
ATTR "Max. start period"
ENDGROUP
GROUP "Conflict strategies"
ATTR "Priority"
ATTR "Max. resource waiting time"
ENDGROUP
#-----
CHAPTER "Simulation results"
#-----
ATTR "Number" write-protected
GROUP "Aggregated times"
ATTR "Aggregated execution time" write-protected
ATTR "Aggregated waiting time" write-protected
ATTR "Aggregated resting time" write-protected
ATTR "Aggregated transport time" write-protected
ENDGROUP
GROUP "Aggregated costs"
ATTR "Aggregated costs" write-protected
ATTR "Aggregated personnel costs" write-protected
ENDGROUP
ATTR "Info on results" write-protected lines:5
#-----
#CHAPTER "Externe Toolanbindung"
#-----
#ATTR "Externe Toolanbindung" write-protected
#-----
CHAPTER "Deutsch"
#-----
GROUP "Aktivität"
ATTR "Bezeichnung"
ATTR "Beschreibung" lines:5
ATTR "Kommentar" lines:5
ENDGROUP
#-----
LANG "de"
#-----
#-----
CHAPTER "Beschreibung (deutsch)"
#-----
GROUP "Aktivität"
ATTR "Bezeichnung"
ATTR "Beschreibung" lines:5
ATTR "Kommentar" lines:5
ENDGROUP
#-----
CHAPTER "Beschreibung"

```

Part IV

```
#-----
ATTR "Name"
ATTR "Order"
ATTR "Description" lines:5
ATTR "Comment" lines:5
GROUP "Responsible role"
ATTR "Responsible role"
ATTR "Display responsible role" ctrltype:check checked-value:"Yes" unchecked-
value:"No"
ENDGROUP
ATTR "Classification"
ATTR "Open questions" lines:5
#-----
CHAPTER "RACI/DEMI"
#-----
ATTR "Responsible for execution"
ATTR "Accountable for approving results"
ATTR "Cooperation/participation" lines:3
ATTR "To inform" lines:3
#-----
CHAPTER "Dokumente"
#-----
ATTR "Input"
ATTR "Output"
ATTR "Referenced documents"
ATTR "External documentation"
#-----
CHAPTER "Systeme"
#-----
ATTR "Referenced IT system elements"
ATTR "Visualise referenced IT system elements" ctrltype:check
ATTR "Referenced use cases"
#-----
CHAPTER "Produkte"
#-----
ATTR "Referenced products"
#-----
CHAPTER "Zeiten/Kosten"
#-----
GROUP "Activity times"
ATTR "Execution time"
ATTR "Waiting time"
ATTR "Resting time"
ATTR "Transport time"
ENDGROUP
GROUP "Activity costs"
ATTR "Costs"
ENDGROUP
GROUP "Process cost analysis"
ATTR "EDP transaction costs"
ATTR "EDP batch costs"
ATTR "Printing costs"
ATTR "Postal costs"
ENDGROUP
#-----
CHAPTER "Arbeitsumgebung"
#-----
GROUP "Simulation"
ATTR "Performer" dialog:actor lines:3
ATTR "Continuous execution" ctrltype:check checked-value:"yes" unchecked-value:"no"
```



```

ATTR "Execution interruptable" ctrltype:check checked-value:"yes" unchecked-
value:"no"
ATTR "Task stack"
ATTR "Done by"
ENDGROUP
#-----
CHAPTER "Sonstige Simulationsdaten"
#-----
GROUP "Cooperation"
ATTR "Cooperative" ctrltype:check checked-value:"yes" unchecked-value:"no"
ATTR "Cooperation mode" ctrltype:radio
ATTR "Average number of participants"
ATTR "Min. quota of presence"
ATTR "Max. start period"
ENDGROUP
GROUP "Conflict strategies"
ATTR "Priority"
ATTR "Max. resource waiting time"
ENDGROUP
#-----
CHAPTER "Auswertungsergebnisse"
#-----
ATTR "Number" write-protected
GROUP "Times"
ATTR "Aggregated execution time" write-protected
ATTR "Aggregated waiting time" write-protected
ATTR "Aggregated resting time" write-protected
ATTR "Aggregated transport time" write-protected
ENDGROUP
GROUP "Costs"
ATTR "Aggregated costs" write-protected
ATTR "Aggregated personnel costs" write-protected
ENDGROUP
ATTR "Info on results" write-protected lines:5
#-----
#CHAPTER "External tool coupling"
#-----
#ATTR "Externe Toolanbindung" write-protected

```

1.2.8 Class "Decision"

ADONIS BPMS BP Library 3.9:

```

NOTEBOOK
#-----
LANG "en"
#-----
CHAPTER "Description"
ATTR "Name"
ATTR "Order"
ATTR "Description" lines:5
ATTR "Comment" lines:5
ATTR "Open questions" lines:5
CHAPTER "Deutsch"
GROUP "Entscheidung"
ATTR "Bezeichnung"
ATTR "Beschreibung" lines:5
ATTR "Kommentar" lines:5
ENDGROUP

```

Part IV

```
#-----  
LANG "de"  
#-----  
CHAPTER "Beschreibung (deutsch)"  
GROUP "Entscheidung"  
ATTR "Bezeichnung"  
ATTR "Beschreibung" lines:5  
ATTR "Kommentar" lines:5  
ENDGROUP  
CHAPTER "Beschreibung"  
ATTR "Name"  
ATTR "Order"  
ATTR "Description" lines:5  
ATTR "Comment" lines:5  
ATTR "Open questions" lines:5
```

1.2.9 Class "Parallellity"

ADONIS BPMS BP Library 3.9:

```
NOTEBOOK  
#-----  
LANG "en"  
#-----  
CHAPTER "Description"  
ATTR "Name"  
ATTR "Representation"  
ATTR "Modeling direction"  
#ATTR "Modeling direction (Model)"  
ATTR "Change modelling direction (global)" push-button no-param  
ATTR "Order"  
ATTR "Description" lines:5  
ATTR "Comment" lines:5  
CHAPTER "Deutsch"  
GROUP "Parallellität"  
ATTR "Bezeichnung"  
ATTR "Beschreibung" lines:5  
ATTR "Kommentar" lines:5  
ENDGROUP  
#-----  
LANG "de"  
#-----  
CHAPTER "Beschreibung (deutsch)"  
GROUP "Parallellität"  
ATTR "Bezeichnung"  
ATTR "Beschreibung" lines:5  
ATTR "Kommentar" lines:5  
ENDGROUP  
CHAPTER "Beschreibung"  
ATTR "Name"  
ATTR "Representation"  
ATTR "Change modelling direction (global)" push-button no-param  
ATTR "Order"  
ATTR "Description" lines:5  
ATTR "Comment" lines:5
```

1.2.10 Class "Merging"

ADONIS BPMS BP Library 3.9:

```

NOTEBOOK
#-----
LANG "en"
#-----
CHAPTER "Description"
ATTR "Name"
ATTR "Representation"
ATTR "Change modelling direction (global)" push-button no-param
ATTR "Order"
ATTR "Description" lines:5
ATTR "Comment" lines:5
CHAPTER "Deutsch"
GROUP "Vereinigung"
ATTR "Bezeichnung"
ATTR "Beschreibung" lines:5
ATTR "Kommentar" lines:5
ENDGROUP
#-----
LANG "de"
#-----
CHAPTER "Beschreibung (deutsch)"
GROUP "Vereinigung"
ATTR "Bezeichnung"
ATTR "Beschreibung" lines:5
ATTR "Kommentar" lines:5
ENDGROUP
CHAPTER "Beschreibung"
ATTR "Name"
ATTR "Representation"
ATTR "Change modelling direction (global)" push-button no-param
ATTR "Order"
ATTR "Description" lines:5
ATTR "Comment" lines:5

```

1.2.11 Class "End"

ADONIS BPMS BP Library 3.9:

```

NOTEBOOK
#-----
LANG "en"
#-----
CHAPTER "Description"
ATTR "Name"
ATTR "Representation"
ATTR "Order"
ATTR "Type" ctrltype:radio
ATTR "Description" lines:5
ATTR "Comment" lines:5
CHAPTER "Deutsch"
GROUP "Ende"
ATTR "Bezeichnung"
ATTR "Beschreibung" lines:5
ATTR "Kommentar" lines:5
ENDGROUP

```

Part IV

```
#-----  
LANG "de"  
#-----  
CHAPTER "Beschreibung (deutsch)"  
GROUP "Ende"  
ATTR "Bezeichnung"  
ATTR "Beschreibung" lines:5  
ATTR "Kommentar" lines:5  
ENDGROUP  
CHAPTER "Beschreibung"  
ATTR "Name"  
ATTR "Representation"  
ATTR "Order"  
ATTR "Type" ctrltype:radio  
ATTR "Description" lines:5  
ATTR "Comment" lines:5
```

1.2.12 Class "Variable"

ADONIS BPMS BP Library 3.9:

```
NOTEBOOK  
#-----  
LANG "en"  
#-----  
CHAPTER "Description"  
ATTR "Name"  
ATTR "Description" lines:5  
ATTR "Comment" lines:5  
ATTR "Variable type"  
ATTR "Variable scope"  
CHAPTER "Deutsch"  
GROUP "Variable"  
ATTR "Bezeichnung"  
ATTR "Beschreibung" lines:5  
ATTR "Kommentar" lines:5  
ENDGROUP  
#-----  
LANG "de"  
#-----  
CHAPTER "Beschreibung (deutsch)"  
GROUP "Variable"  
ATTR "Bezeichnung"  
ATTR "Beschreibung" lines:5  
ATTR "Kommentar" lines:5  
ENDGROUP  
CHAPTER "Beschreibung"  
ATTR "Name"  
ATTR "Description" lines:5  
ATTR "Comment" lines:5  
ATTR "Variable type"  
ATTR "Variable scope"
```

1.2.13 Class "Random generator"

ADONIS BPMS BP Library 3.9:

```
NOTEBOOK
```

```

#-----
LANG "en"
#-----
CHAPTER "Description"
ATTR "Value" dialog:distribution
ATTR "Name"
ATTR "Description" lines:5
ATTR "Comment" lines:5
ATTR "Information on data collection"
ATTR "Manual random generator" ctrltype:check checked-value:"yes" unchecked-
value:"no"
CHAPTER "Deutsch"
ATTR "Info zum Wert der Variablenbelegung"
ATTR "Beschreibung" lines:5
ATTR "Kommentar" lines:5
#-----
LANG "de"
#-----
CHAPTER "Beschreibung (deutsch)"
ATTR "Info zum Wert der Variablenbelegung"
ATTR "Beschreibung" lines:5
ATTR "Kommentar" lines:5
CHAPTER "Beschreibung"
ATTR "Value" dialog:distribution
ATTR "Name"
ATTR "Description" lines:5
ATTR "Comment" lines:5
ATTR "Information on data collection"
ATTR "Manual random generator" ctrltype:check checked-value:"yes" unchecked-
value:"no"

```

1.2.14 Class "Resource"

ADONIS BPMS BP Library 3.9:

```

NOTEBOOK
#-----
LANG "en"
#-----
CHAPTER "Description"
ATTR "Name"
ATTR "Order"
ATTR "Description" lines:5
ATTR "Comment" lines:5
ATTR "Type of resource"
ATTR "Screenshot"
ATTR "Selection" dialog:resource lines:3
CHAPTER "Deutsch"
GROUP "Ressource"
ATTR "Bezeichnung"
ATTR "Beschreibung" lines:5
ATTR "Kommentar" lines:5
ENDGROUP
#-----
LANG "de"
#-----
CHAPTER "Beschreibung (deutsch)"
GROUP "Ressource"
ATTR "Bezeichnung"

```

Part IV

```
ATTR "Beschreibung" lines:5
ATTR "Kommentar" lines:5
ENDGROUP
CHAPTER "Beschreibung"
ATTR "Name"
ATTR "Order"
ATTR "Description" lines:5
ATTR "Comment" lines:5
ATTR "Type of resource"
ATTR "Screenshot"
ATTR "Selection" dialog:resource lines:3
```

1.2.15 Class "Process"

ADONIS BPMS BP Library 3.9:

```
NOTEBOOK
#-----
LANG "en"
#-----
CHAPTER "Description"
GROUP "Representation"
ATTR "Name"
ATTR "Referenced process"
ATTR "Display name and reference" ctrltype:check checked-value:"yes" unchecked-
value:"no"
ENDGROUP
ATTR "Order"
ATTR "Description" lines:5
ATTR "Comment" lines:5
ATTR "External process" ctrltype:check checked-value:"yes" unchecked-value:"no"
ATTR "Referenced IT system elements"
ATTR "Visualise referenced IT system elements" ctrltype:check
ATTR "Open questions" lines:5
CHAPTER "Input/Output"
ATTR "Input"
ATTR "Output"
CHAPTER "Simulation results"
GROUP "Times"
ATTR "Aggregated cycle time" write-protected
ATTR "Aggregated execution time" write-protected
ATTR "Aggregated waiting time" write-protected
ATTR "Aggregated resting time" write-protected
ATTR "Aggregated transport time" write-protected
ENDGROUP
GROUP "Costs"
ATTR "Aggregated costs" write-protected
ATTR "Aggregated personnel costs" write-protected
ENDGROUP
CHAPTER "Representation"
ATTR "Color" dialog:color
ATTR "Font size"
CHAPTER "Deutsch"
GROUP "Prozess"
ATTR "Bezeichnung"
ATTR "Beschreibung" lines:5
ATTR "Kommentar" lines:5
ENDGROUP
#-----
```

```

LANG "de"
#-----
CHAPTER "Beschreibung (deutsch) "
GROUP "Prozess"
ATTR "Bezeichnung"
ATTR "Beschreibung" lines:5
ATTR "Kommentar" lines:5
ENDGROUP
CHAPTER "Beschreibung"
GROUP "Representation"
ATTR "Name"
ATTR "Referenced process"
ATTR "Display name and reference" ctrltype:check checked-value:"yes" unchecked-
value:"no"
ENDGROUP
ATTR "Order"
ATTR "Description" lines:5
ATTR "Comment" lines:5
ATTR "External process" ctrltype:check checked-value:"yes" unchecked-value:"no"
ATTR "Referenced IT system elements"
ATTR "Visualise referenced IT system elements" ctrltype:check
ATTR "Open questions" lines:5
CHAPTER "Input/Output"
ATTR "Input"
ATTR "Output"
CHAPTER "Auswertungsergebnisse"
GROUP "Times"
ATTR "Aggregated cycle time" write-protected
ATTR "Aggregated execution time" write-protected
ATTR "Aggregated waiting time" write-protected
ATTR "Aggregated resting time" write-protected
ATTR "Aggregated transport time" write-protected
ENDGROUP
GROUP "Costs"
ATTR "Aggregated costs" write-protected
ATTR "Aggregated personnel costs" write-protected
ENDGROUP
CHAPTER "Darstellung"
ATTR "Color" dialog:color
ATTR "Font size"

```

1.2.16 Class "Performance indicator overview"

ADONIS BPMS BP Library 3.9:

```

NOTEBOOK
#-----
LANG "en"
#-----
CHAPTER "Description"
ATTR "Name"
ATTR "Description" lines:5
ATTR "Comment" lines:5
CHAPTER "Performance indicators"
ATTR "Performance indicator overview" lines:5
CHAPTER "Database parameter"
ATTR "Database access"
CHAPTER "Period configuration"
ATTR "Planning period"

```

Part IV

```
#CHAPTER "Cockpit"
#GROUP "Visualization"
#ATTR "Display current value" ctrltype:check checked-value:"1" unchecked-value:"0"
#ATTR "Display score" ctrltype:check checked-value:"yes" unchecked-value:"no"
#ATTR "Display periodicity" ctrltype:check checked-value:"1" unchecked-value:"0"
#ATTR "Display status" ctrltype:check checked-value:"1" unchecked-value:"0"
#ATTR "Display weighting" ctrltype:check checked-value:"1" unchecked-value:"0"
#ENDGROUP
CHAPTER "Deutsch"
GROUP "Kennzahlenübersicht"
ATTR "Bezeichnung"
ATTR "Beschreibung" lines:5
ATTR "Kommentar" lines:5
ENDGROUP
#-----
LANG "de"
#-----
CHAPTER "Beschreibung (deutsch)"
GROUP "Kennzahlenübersicht"
ATTR "Bezeichnung"
ATTR "Beschreibung" lines:5
ATTR "Kommentar" lines:5
ENDGROUP
CHAPTER "Beschreibung"
ATTR "Name"
ATTR "Description" lines:5
ATTR "Comment" lines:5
CHAPTER "Performance indicators"
ATTR "Performance indicator overview" lines:5
CHAPTER "Database parameters"
ATTR "Database access"
CHAPTER "Period configuration"
ATTR "Planning period"
```

1.2.17 Class "Performance indicator"

ADONIS BPMS BP Library 3.9:

```
NOTEBOOK
#-----
LANG "en"
#-----
CHAPTER "Description"
ATTR "Name"
ATTR "Order"
ATTR "Description" lines:5
ATTR "Comment" lines:5
CHAPTER "Details"
GROUP "Performance indicator details"
ATTR "Periodicity" ctrltype:dropdown
ATTR "Change of referenced date (year)"
ATTR "Change of referenced date (month)"
ENDGROUP
ATTR "Indicator type"
ATTR "Unit"
ATTR "Limit type" ctrltype:dropdown
ATTR "Threshold green/yellow"
ATTR "Threshold yellow/red"
ATTR "Responsibility"
```



```

ATTR "Data source" ctrltype:dropwon
ENDGROUP
CHAPTER "History"
ATTR "History" lines:15
CHAPTER "DB data source"
#ATTR "Data source" ctrltype:dropwon
ATTR "SELECT-Statement" lines:13
CHAPTER "Excel data source"
#ATTR "Data source" ctrltype:dropwon
ATTR "Table"
ATTR "Sheet"
ATTR "Cell"
CHAPTER "Manual data source"
#ATTR "Data source" ctrltype:dropwon
ATTR "Manual data input"
CHAPTER "Representation"
ATTR "Font size"
ATTR "Font style"
GROUP "Visualisation"
ATTR "Display current value" ctrltype:check checked-value:"1" unchecked-value:"0"
ATTR "Display score" ctrltype:check checked-value:"1" unchecked-value:"0"
ATTR "Display periodicity" ctrltype:check checked-value:"1" unchecked-value:"0"
ATTR "Display status" ctrltype:check checked-value:"1" unchecked-value:"0"
ENDGROUP
CHAPTER "Deutsch"
GROUP "Kennzahl"
ATTR "Bezeichnung"
ATTR "Beschreibung" lines:5
ATTR "Kommentar" lines:5
ENDGROUP
#-----
LANG "de"
#-----
CHAPTER "Beschreibung (deutsch)"
GROUP "Kennzahl"
ATTR "Bezeichnung"
ATTR "Beschreibung" lines:5
ATTR "Kommentar" lines:5
ENDGROUP
CHAPTER "Beschreibung"
ATTR "Name"
ATTR "Order"
ATTR "Description" lines:5
ATTR "Comment" lines:5
CHAPTER "Details"
GROUP "Performance indicator details"
ATTR "Periodicity" ctrltype:dropdown
ATTR "Change of referenced date (year)"
ATTR "Change of referenced date (month)"
ENDGROUP
ATTR "Indicator type"
ATTR "Unit"
ATTR "Limit type" ctrltype:dropdown
ATTR "Threshold green/yellow"
ATTR "Threshold yellow/red"
ATTR "Responsibility"
ATTR "Data source" ctrltype:dropwon
ENDGROUP
CHAPTER "Zielwerte"
ATTR "History" lines:15
CHAPTER "DB Datenquelle"

```

Part IV

```
#ATTR "Databums" ctrltype:dropwon
ATTR "SELECT-Statement" lines:13
CHAPTER "Excel-Datenquelle"
#ATTR "Data source" ctrltype:dropwon
ATTR "Table"
ATTR "Sheet"
ATTR "Cell"
CHAPTER "Manuelle Datenquelle"
#ATTR "Data source" ctrltype:dropwon
ATTR "Manual data input"
CHAPTER "Darstellung"
ATTR "Font size"
ATTR "Font style"
GROUP "Visualisation"
ATTR "Display current value" ctrltype:check checked-value:"1" unchecked-value:"0"
ATTR "Display score" ctrltype:check checked-value:"1" unchecked-value:"0"
ATTR "Display periodicity" ctrltype:check checked-value:"1" unchecked-value:"0"
ATTR "Display status" ctrltype:check checked-value:"1" unchecked-value:"0"
ENDGROUP
```

1.2.18 Class "Document"

ADONIS BPMS BP Library 3.9:

```
NOTEBOOK
#-----
LANG "en"
#-----
CHAPTER "Description"
ATTR "Name"
ATTR "Referenced document"
ATTR "Display file extension" ctrltype:check
ATTR "Description" lines:5
ATTR "Comment" lines:5
ATTR "Responsible role"
ATTR "Referenced document model"
CHAPTER "Deutsch"
GROUP "Dokument"
ATTR "Bezeichnung"
ATTR "Beschreibung" lines:5
ATTR "Kommentar" lines:5
ENDGROUP
#-----
LANG "de"
#-----
CHAPTER "Beschreibung (deutsch)"
GROUP "Dokument"
ATTR "Bezeichnung"
ATTR "Beschreibung" lines:5
ATTR "Kommentar" lines:5
ENDGROUP
CHAPTER "Beschreibung"
ATTR "Name"
ATTR "Referenced document"
ATTR "Display file extension" ctrltype:check
ATTR "Description" lines:5
ATTR "Comment" lines:5
ATTR "Responsible role"
ATTR "Referenced document model"
```

1.2.19 Class "Note"

ADONIS BPMS BP Library 3.9:

```

NOTEBOOK
#-----
LANG "en"
#-----
CHAPTER "Description"
ATTR "Text" lines:15
ATTR "Font size"
ATTR "Font style"
ATTR "Color" dialog:color
ATTR "External graphic"
ATTR "Calculate size of graphic automatically" ctrltype:check checked-value:"Yes"
unchecked-value:"No"
CHAPTER "Deutsch"
ATTR "Notiz" lines:15
#-----
LANG "en"
#-----
CHAPTER "Beschreibung (deutsch)"
ATTR "Notiz" lines:15
CHAPTER "Beschreibung"
ATTR "Text" lines:15
ATTR "Font size"
ATTR "Font style"
ATTR "Color" dialog:color
ATTR "External graphic"
ATTR "Calculate size of graphic automatically" ctrltype:check checked-value:"Yes"
unchecked-value:"No"

```

1.2.20 Class "Aggregation"

ADONIS BPMS BP Library 3.9:

```

NOTEBOOK
#-----
LANG "en"
#-----
CHAPTER "Description"
ATTR "Name"
GROUP "Name display"
ATTR "Display name" ctrltype:check checked-value:"Yes" unchecked-value:"No"
ATTR "Representation"
ATTR "Font size"
ATTR "Font style"
ENDGROUP
ATTR "Description" lines:5
ATTR "Comment" lines:5
CHAPTER "Object display"
ATTR "Graphical representation"
ATTR "Color" dialog:color
ATTR "Lines"
CHAPTER "Deutsch"
GROUP "Aggregation"
ATTR "Bezeichnung"
ATTR "Beschreibung" lines:5
ATTR "Kommentar" lines:5

```

Part IV

```
ENDGROUP
#-----
LANG "de"
#-----
CHAPTER "Beschreibung (deutsch)"
GROUP "Aggregation"
ATTR "Bezeichnung"
ATTR "Beschreibung" lines:5
ATTR "Kommentar" lines:5
ENDGROUP
CHAPTER "Beschreibung"
ATTR "Name"
GROUP "Name display"
ATTR "Display name" ctrltype:check checked-value:"Yes" unchecked-value:"No"
ATTR "Representation"
ATTR "Font size"
ATTR "Font style"
ENDGROUP
ATTR "Description" lines:5
ATTR "Comment" lines:5
CHAPTER "Objektanzeige"
ATTR "Graphical representation"
ATTR "Color" dialog:color
ATTR "Lines"
```

1.2.21 Class "Swimlane (horizontal)"

ADONIS BPMS BP Library 3.9:

```
NOTEBOOK
#-----
LANG "en"
#-----
CHAPTER "Description"
ATTR "Name"
ATTR "Working environment"
ATTR "Referenced IT system elements"
ATTR "Description" lines:5
ATTR "Comment" lines:5
ATTR "Open questions" lines:5
CHAPTER "Representation"
GROUP "Swimlane"
ATTR "Color" dialog:color
ATTR "Display water marks" ctrltype:check unchecked-value:"no" checked-value:"yes"
ENDGROUP
GROUP "Text"
ATTR "Alignment" ctrltype:dropdown
ENDGROUP
CHAPTER "Deutsch"
GROUP "Schwimmbahn"
ATTR "Bezeichnung"
ATTR "Beschreibung" lines:5
ATTR "Kommentar" lines:5
ENDGROUP
#-----
LANG "de"
#-----
CHAPTER "Beschreibung (deutsch)"
GROUP "Schwimmbahn"
```

```

ATTR "Bezeichnung"
ATTR "Beschreibung" lines:5
ATTR "Kommentar" lines:5
ENDGROUP
CHAPTER "Beschreibung"
ATTR "Name"
ATTR "Working environment"
ATTR "Referenced IT system elements"
ATTR "Description" lines:5
ATTR "Comment" lines:5
ATTR "Open questions" lines:5
CHAPTER "Darstellung"
GROUP "Swimlane"
ATTR "Color" dialog:color
ATTR "Display water marks" ctrltype:check unchecked-value:"no" checked-value:"yes"
ENDGROUP
GROUP "Text"
ATTR "Alignment" ctrltype:dropdown
ENDGROUP

```

1.2.22 Class "Swimlane (vertical)"

ADONIS BPMS BP Library 3.9:

```

NOTEBOOK
#-----
LANG "en"
#-----
CHAPTER "Description"
ATTR "Name"
ATTR "Working environment"
ATTR "Referenced IT system elements"
ATTR "Description" lines:5
ATTR "Comment" lines:5
ATTR "Open questions" lines:5
CHAPTER "Representation"
GROUP "Swimlane"
ATTR "Color" dialog:color
ATTR "Display water marks" ctrltype:check unchecked-value:"no" checked-value:"yes"
ENDGROUP
GROUP "Text"
ATTR "Alignment" ctrltype:dropdown
ENDGROUP
CHAPTER "Deutsch"
GROUP "Schwimmbahn"
ATTR "Bezeichnung"
ATTR "Beschreibung" lines:5
ATTR "Kommentar" lines:5
ENDGROUP
#-----
LANG "de"
#-----
CHAPTER "Beschreibung (deutsch)"
GROUP "Schwimmbahn"
ATTR "Bezeichnung"
ATTR "Beschreibung" lines:5
ATTR "Kommentar" lines:5
ENDGROUP
CHAPTER "Beschreibung"

```

Part IV

```
ATTR "Name"
ATTR "Working environment"
ATTR "Referenced IT system elements"
ATTR "Description" lines:5
ATTR "Comment" lines:5
ATTR "Open questions" lines:5
CHAPTER "Darstellung"
GROUP "Swimlane"
ATTR "Color" dialog:color
ATTR "Display water marks" ctrltype:check unchecked-value:"no" checked-value:"yes"
ENDGROUP
GROUP "Text"
ATTR "Alignment" ctrltype:dropdown
ENDGROUP
```

1.2.23 Class "External partner"

ADONIS BPMS BP Library 3.9:

```
NOTEBOOK
#-----
LANG "en"
#-----
CHAPTER "Description"
ATTR "Name"
ATTR "Referenced organizational unit"
ATTR "Description" lines:5
ATTR "Comment" lines:5
CHAPTER "Deutsch"
ATTR "Bezeichnung"
ATTR "Beschreibung" lines:5
ATTR "Kommentar" lines:5
#-----
LANG "de"
#-----
CHAPTER "Beschreibung (deutsch)"
ATTR "Bezeichnung"
ATTR "Beschreibung" lines:5
ATTR "Kommentar" lines:5
CHAPTER "Beschreibung"
ATTR "Name"
ATTR "Referenced organizational unit"
ATTR "Description" lines:5
ATTR "Comment" lines:5
```

1.2.24 Class "Product"

ADONIS BPMS BP Library 3.9:

```
NOTEBOOK
#-----
LANG "en"
#-----
CHAPTER "Description"
ATTR "Name"
ATTR "Description"
ATTR "Comment"
ATTR "External documentation"
```

```

ATTR "Open questions"
CHAPTER "Costs"
GROUP "Costs - Product"
ATTR "Total costs"
ATTR "Specific costs"
ATTR "Display costs" ctrltype:check
CHAPTER "References"
ATTR "Product responsibility"
ATTR "Referenced product model"
ATTR "Referenced documents"
ATTR "Referenced processes"
ATTR "Referenced IT system elements"
CHAPTER "Deutsch"
ATTR "Bezeichnung"
ATTR "Beschreibung"
ATTR "Kommentar"
#-----
LANG "de"
#-----
CHAPTER "Beschreibung (deutsch) "
ATTR "Bezeichnung"
ATTR "Beschreibung"
ATTR "Kommentar"
CHAPTER "Beschreibung"
ATTR "Name"
ATTR "Description"
ATTR "Comment"
ATTR "External documentation"
ATTR "Open questions"
CHAPTER "Kosten"
GROUP "Costs - Product"
ATTR "Total costs"
ATTR "Specific costs"
ATTR "Display costs" ctrltype:check
CHAPTER "Referenzen"
ATTR "Product responsibility"
ATTR "Referenced product model"
ATTR "Referenced documents"
ATTR "Referenced processes"
ATTR "Referenced IT system elements"

```

1.2.25 Class "Product component"

ADONIS BPMS BP Library 3.9:

```

NOTEBOOK
#-----
LANG "en"
#-----
CHAPTER "Description"
ATTR "Name"
ATTR "Description"
ATTR "Comment"
ATTR "External documentation"
ATTR "Open questions"
CHAPTER "Costs"
GROUP "Costs - product component"
ATTR "Total costs"
ATTR "Specific costs"

```

Part IV

```
ATTR "Display costs" ctrltype:check
CHAPTER "References"
ATTR "Component responsibility"
ATTR "Referenced product model"
ATTR "Referenced documents"
ATTR "Referenced processes"
ATTR "Referenced IT system elements"
CHAPTER "Deutsch"
ATTR "Bezeichnung"
ATTR "Beschreibung"
ATTR "Kommentar"
#-----
LANG "de"
#-----
CHAPTER "Beschreibung (deutsch)"
ATTR "Bezeichnung"
ATTR "Beschreibung"
ATTR "Kommentar"
CHAPTER "Beschreibung"
ATTR "Name"
ATTR "Description"
ATTR "Comment"
ATTR "External documentation"
ATTR "Open questions"
CHAPTER "Kosten"
GROUP "Costs - product component"
ATTR "Total costs"
ATTR "Specific costs"
ATTR "Display costs" ctrltype:check
CHAPTER "Referenzen"
ATTR "Component responsibility"
ATTR "Referenced product model"
ATTR "Referenced documents"
ATTR "Referenced processes"
ATTR "Referenced IT system elements"
```

1.2.26 Class "Application"

ADONIS BPMS BP Library 3.9:

```
NOTEBOOK
#-----
LANG "en"
#-----
CHAPTER "Description"
ATTR "Name"
ATTR "Version"
ATTR "Description"
ATTR "Comment"
ATTR "Application responsibility"
ATTR "Type of application"
ATTR "Other"
ATTR "Screenshot"
ATTR "External documentation"
ATTR "Referenced documents"
ATTR "Open questions"
ATTR "Referenced IT system model"
CHAPTER "Input/Output"
ATTR "Input"
```



```

ATTR "Output"
CHAPTER "Properties"
ATTR "Properties"
CHAPTER "Deutsch"
ATTR "Bezeichnung"
ATTR "Description"
ATTR "Comment"
#-----
LANG "de"
#-----
CHAPTER "Beschreibung (deutsch)"
ATTR "Bezeichnung"
ATTR "Beschreibung"
ATTR "Kommentar"
CHAPTER "Beschreibung"
ATTR "Name"
ATTR "Version"
ATTR "Description"
ATTR "Comment"
ATTR "Application responsibility"
ATTR "Type of application"
ATTR "Other"
ATTR "Screenshot"
ATTR "External documentation"
ATTR "Referenced documents"
ATTR "Open questions"
ATTR "Referenced IT system model"
CHAPTER "Input/Output"
ATTR "Input"
ATTR "Output"
CHAPTER "Eigenschaften"
ATTR "Properties"

```

1.2.27 Class "Service"

ADONIS BPMS BP Library 3.9:

```

NOTEBOOK
#-----
LANG "en"
#-----
CHAPTER "Description"
ATTR "Name"
ATTR "Version"
ATTR "Description"
ATTR "Comment"
ATTR "Service responsibility"
ATTR "Screenshot"
ATTR "External documentation"
ATTR "Referenced documents"
ATTR "Open questions"
ATTR "Referenced IT system model"
CHAPTER "Input/Output"
ATTR "Input"
ATTR "Output"
CHAPTER "Properties"
ATTR "Properties"
CHAPTER "Deutsch"
ATTR "Bezeichnung"

```

Part IV

```
ATTR "Beschreibung"
ATTR "Kommentar"
#-----
LANG "de"
#-----
CHAPTER "Beschreibung (deutsch)"
ATTR "Bezeichnung"
ATTR "Beschreibung"
ATTR "Kommentar"
CHAPTER "Beschreibung"
ATTR "Name"
ATTR "Version"
ATTR "Description"
ATTR "Comment"
ATTR "Service responsibility"
ATTR "Screenshot"
ATTR "External documentation"
ATTR "Referenced documents"
ATTR "Open questions"
ATTR "Referenced IT system model"
CHAPTER "Input/Output"
ATTR "Input"
ATTR "Output"
CHAPTER "Eigenschaften"
ATTR "Properties"
```

1.2.28 Class "Performance"

ADONIS BPMS BP Library 3.9:

```
NOTEBOOK
#-----
LANG "en"
#-----
CHAPTER "Description"
ATTR "Name"
ATTR "Referenced element"
ATTR "Description"
ATTR "Comment"
ATTR "External documentation"
ATTR "Referenced documents"
ATTR "Open questions"
CHAPTER "Deutsch"
ATTR "Bezeichnung"
ATTR "Beschreibung"
ATTR "Kommentar"
#-----
LANG "de"
#-----
CHAPTER "Beschreibung (deutsch)"
ATTR "Bezeichnung"
ATTR "Beschreibung"
ATTR "Kommentar"
CHAPTER "Beschreibung"
ATTR "Name"
ATTR "Referenced element"
ATTR "Description"
ATTR "Comment"
ATTR "External documentation"
```

ATTR "Referenced documents"
ATTR "Open questions"

1.2.29 Class "Infrastructure element"

ADONIS BPMS BP Library 3.9:

```
NOTEBOOK
#-----
LANG "en"
#-----
CHAPTER "Description"
ATTR "Name"
ATTR "Version"
ATTR "Description"
ATTR "Comment"
ATTR "Service responsibility"
ATTR "Screenshot"
ATTR "External documentation"
ATTR "Referenced documents"
ATTR "Open questions"
ATTR "Referenced IT system model"
CHAPTER "Input/Output"
ATTR "Input"
ATTR "Output"
CHAPTER "Properties"
ATTR "Properties"
CHAPTER "Deutsch"
ATTR "Bezeichnung"
ATTR "Beschreibung"
ATTR "Kommentar"
#-----
LANG "de"
#-----
CHAPTER "Beschreibung (deutsch)"
ATTR "Bezeichnung"
ATTR "Beschreibung"
ATTR "Kommentar"
CHAPTER "Beschreibung"
ATTR "Name"
ATTR "Version"
ATTR "Description"
ATTR "Comment"
ATTR "Service responsibility"
ATTR "Screenshot"
ATTR "External documentation"
ATTR "Referenced documents"
ATTR "Open questions"
ATTR "Referenced IT system model"
CHAPTER "Input/Output"
ATTR "Input"
ATTR "Output"
CHAPTER "Eigenschaften"
ATTR "Properties"
```

1.2.30 Class "Cross-reference"

ADONIS BPMS BP Library 3.9:

Part IV

```
NOTEBOOK
#-----
LANG "en"
#-----
CHAPTER "Description"
ATTR "Name"
GROUP "Cross-reference"
ATTR "Cross-reference"
ATTR "Type of Cross-reference"
ENDGROUP
ATTR "Description"
ATTR "Comment"
CHAPTER "Deutsch"
ATTR "Bezeichnung"
ATTR "Beschreibung"
ATTR "Kommentar"
#-----
LANG "de"
#-----
CHAPTER "Beschreibung (deutsch)"
ATTR "Bezeichnung"
ATTR "Beschreibung"
ATTR "Kommentar"
CHAPTER "Beschreibung"
ATTR "Name"
GROUP "Cross-reference"
ATTR "Cross-reference"
ATTR "Type of Cross-reference"
ENDGROUP
ATTR "Description"
ATTR "Comment"
```

1.2.31 Class "Organizational unit"

ADONIS BPMS WE Library 3.9:

```
NOTEBOOK
#-----
LANG "en"
#-----
CHAPTER "Description"
  ATTR "Name"
  ATTR "Order"
  ATTR "Description" lines:5
  ATTR "Comment" lines:5
  ATTR "Model reference"
CHAPTER "Information about organizational unit"
  GROUP "Information about organizational unit"
    ATTR "Type" ctrltype:dropdown
    ATTR "Functional unit"
    ATTR "Cost center"
    ATTR "Referenced organigram"
  ENDMETHOD
  ATTR "Organigram variant" ctrltype:dropdown
CHAPTER "Additional information"
  GROUP "Additional information"
    ATTR "Manager"
    ATTR "Function"
  ENDMETHOD
```

```

CHAPTER "Indicators for organizational unit"
GROUP "Absolute indicators"
  ATTR "Planned number of positions (Org.- absolute)"
  ATTR "Number of occupied positions (Org.- absolute)"
  ATTR "Number of open positions (Org.- absolute)"
ENDGROUP
GROUP "Relative indicators"
  ATTR "Planned number of positions (Org.- relative)"
  ATTR "Number of occupied positions (Org.- relative)"
  ATTR "Number of open positions (Org.- relative)"
ENDGROUP
CHAPTER "Aggregated indicators"
GROUP "Absolute indicators"
  ATTR "Planned number of positions (Agg.- absolute)"
  ATTR "Number of occupied positions (Agg.- absolute)"
  ATTR "Number of open positions (Agg.- absolute)"
ENDGROUP
GROUP "Relative indicators"
  ATTR "Planned number of positions (Agg.- relative)"
  ATTR "Number of occupied positions (Agg.- relative)"
  ATTR "Number of open positions (Agg.- relative)"
ENDGROUP
CHAPTER "Deutsch"
GROUP "Organisationseinheit"
  ATTR "Bezeichnung"
  ATTR "Beschreibung" lines:5
  ATTR "Kommentar" lines:5
ENDGROUP
#-----
LANG "de"
#-----
CHAPTER "Beschreibung (deutsch)"
GROUP "Organisationseinheit"
  ATTR "Bezeichnung"
  ATTR "Beschreibung" lines:5
  ATTR "Kommentar" lines:5
ENDGROUP
CHAPTER "Beschreibung"
  ATTR "Name"
  ATTR "Order"
  ATTR "Description" lines:5
  ATTR "Comment" lines:5
  ATTR "Model reference"
CHAPTER "Angaben zur Organisationseinheit"
GROUP "Information about organizational unit"
  ATTR "Type" ctrltype:dropdown
  ATTR "Functional unit"
  ATTR "Cost center"
  ATTR "Referenced organigram"
ENDGROUP
  ATTR "Organigram variant" ctrltype:dropdown
CHAPTER "Zusatzinformationen"
GROUP "Additional information"
  ATTR "Manager"
  ATTR "Function"
ENDGROUP
CHAPTER "Kennzahlen pro OrgEinheit"
GROUP "Absolute indicators"
  ATTR "Planned number of positions (Org.- absolute)"
  ATTR "Number of occupied positions (Org.- absolute)"
  ATTR "Number of open positions (Org.- absolute)"

```

Part IV

```
ENDGROUP
GROUP "Relative indicators"
  ATTR "Planned number of positions (Org.- relative)"
  ATTR "Number of occupied positions (Org.- relative)"
  ATTR "Number of open positions (Org.- relative)"
ENDGROUP
CHAPTER "Aggregierte Kennzahlen"
GROUP "Absolute indicators"
  ATTR "Planned number of positions (Agg.- absolute)"
  ATTR "Number of occupied positions (Agg.- absolute)"
  ATTR "Number of open positions (Agg.- absolute)"
ENDGROUP
GROUP "Relative indicators"
  ATTR "Planned number of positions (Agg.- relative)"
  ATTR "Number of occupied positions (Agg.- relative)"
  ATTR "Number of open positions (Agg.- relative)"
ENDGROUP
```

1.2.32 Class "Performer"

ADONIS BPMS WE Library 3.9:

```
NOTEBOOK
#-----
LANG "en"
#-----
CHAPTER "Description"
ATTR "Name"
ATTR "Description" lines:5
ATTR "Comment" lines:4
ATTR "Further education"
ATTR "Presence"
CHAPTER "Simulation data"
ATTR "Hourly wages"
GROUP "Capacity analysis"
ATTR "Availability"
ENDGROUP
GROUP "Workload analysis"
ATTR "Calendar" dialog:person-calendar
ENDGROUP
GROUP "Process cost analysis"
ATTR "Time dependent costs"
ENDGROUP
CHAPTER "Simulation results"
ATTR "Personnel costs" write-protected
ATTR "Capacity" write-protected
ATTR "Workload" write-protected
ATTR "Info on results" write-protected lines:5
CHAPTER "Deutsch"
GROUP "Bearbeiter"
ATTR "Bezeichnung"
ATTR "Beschreibung" lines:5
ATTR "Kommentar" lines:5
ENDGROUP
#-----
LANG "de"
#-----
CHAPTER "Beschreibung (deutsch)"
GROUP "Bearbeiter"
```

```

ATTR "Bezeichnung"
ATTR "Beschreibung" lines:5
ATTR "Kommentar" lines:5
ENDGROUP
CHAPTER "Beschreibung"
ATTR "Name"
ATTR "Description" lines:5
ATTR "Comment" lines:4
ATTR "Further education"
ATTR "Presence"
CHAPTER "Simulationsdaten"
ATTR "Hourly wages"
GROUP "Capacity analysis"
ATTR "Availability"
ENDGROUP
GROUP "Workload analysis"
ATTR "Calendar" dialog:person-calendar
ENDGROUP
GROUP "Process cost analysis"
ATTR "Time dependent costs"
ENDGROUP
CHAPTER "Auswertungsergebnisse"
ATTR "Personnel costs" write-protected
ATTR "Capacity" write-protected
ATTR "Workload" write-protected
ATTR "Info on results" write-protected lines:5

```

1.2.33 Class "Role"

ADONIS BPMS WE Library 3.9:

```

NOTEBOOK
#-----
LANG "en"
#-----
CHAPTER "Description"
ATTR "Name"
ATTR "Description" lines:5
ATTR "Comment" lines:5
ATTR "Referenced positions"
ATTR "Referenced actor"
CHAPTER "Deutsch"
GROUP "Rolle"
ATTR "Bezeichnung"
ATTR "Beschreibung" lines:5
ATTR "Kommentar" lines:5
ENDGROUP
#-----
LANG "de"
#-----
CHAPTER "Beschreibung (deutsch)"
GROUP "Rolle"
ATTR "Bezeichnung"
ATTR "Beschreibung" lines:5
ATTR "Kommentar" lines:5
ENDGROUP
CHAPTER "Beschreibung"
ATTR "Name"
ATTR "Description" lines:5

```

Part IV

```
ATTR "Comment" lines:5
ATTR "Referenced positions"
ATTR "Referenced actor"
```

1.2.34 Class "Position"

ADONIS BPMS WE Library 3.9:

```
NOTEBOOK
#-----
LANG "en"
#-----
CHAPTER "Information about position"
GROUP "Information about position"
ATTR "Position name"
ATTR "Position capacity"
ATTR "Cost center"
ATTR "Vacant"
ENDGROUP
CHAPTER "Personal information"
GROUP "Personal information"
#ATTR "Owner"
ATTR "Position holders"
ENDGROUP
#-----
LANG "de"
#-----
CHAPTER "Angaben zur Planstelle"
GROUP "Information about position"
ATTR "Position name"
ATTR "Position capacity"
ATTR "Cost center"
ATTR "Vacant"
ENDGROUP
CHAPTER "Personal information"
GROUP "Personal information"
#ATTR "Owner"
ATTR "Position holders"
ENDGROUP
```

1.2.35 Class "Resource"

ADONIS BPMS WE Library 3.9:

```
NOTEBOOK
#-----
LANG "en"
#-----
CHAPTER "Description"
ATTR "Name"
ATTR "Description" lines:5
ATTR "Comment" lines:5
ATTR "Type of resource"
ATTR "Screenshot"
ATTR "Hourly wages"
CHAPTER "Deutsch"
GROUP "Ressource"
ATTR "Bezeichnung"
```



```

ATTR "Beschreibung" lines:5
ATTR "Kommentar" lines:5
ENDGROUP
#-----
LANG "de"
#-----
CHAPTER "Beschreibung (deutsch) "
GROUP "Ressource"
ATTR "Bezeichnung"
ATTR "Beschreibung" lines:5
ATTR "Kommentar" lines:5
ENDGROUP
CHAPTER "Beschreibung"
ATTR "Name"
ATTR "Description" lines:5
ATTR "Comment" lines:5
ATTR "Type of resource"
ATTR "Screenshot"
ATTR "Hourly wages"

```

1.2.36 Class "Cost center"

ADONIS BPMS WE Library 3.9:

```

NOTEBOOK
#-----
LANG "en"
#-----
CHAPTER "Description"
ATTR "Name"
ATTR "Order"
ATTR "Description" lines:5
ATTR "Comment" lines:5
CHAPTER "Data for analysis"
ATTR "Budget"
GROUP "ON processes"
ATTR "ON time"
ATTR "ON fixed costs"
ATTR "ON processes" lines:5
ENDGROUP
CHAPTER "Deutsch"
GROUP "Kostenstelle"
ATTR "Bezeichnung"
ATTR "Beschreibung" lines:5
ATTR "Kommentar" lines:5
ENDGROUP
#-----
LANG "de"
#-----
CHAPTER "Beschreibung (deutsch) "
GROUP "Kostenstelle"
ATTR "Bezeichnung"
ATTR "Beschreibung" lines:5
ATTR "Kommentar" lines:5
ENDGROUP
CHAPTER "Beschreibung"
ATTR "Name"
ATTR "Order"
ATTR "Description" lines:5

```

Part IV

```
ATTR "Comment" lines:5
CHAPTER "Analysedaten"
ATTR "Budget"
GROUP "ON processes"
ATTR "ON time"
ATTR "ON fixed costs"
ATTR "ON processes" lines:5
ENDGROUP
```

1.2.37 Class "Aggregation"

ADONIS BPMS WE Library 3.9:

```
NOTEBOOK
#-----
LANG "en"
#-----
CHAPTER "Description"
ATTR "Name"
GROUP "Name display"
ATTR "Display name" ctrltype:check checked-value:"Yes" unchecked-value:"No"
ATTR "Representation"
ATTR "Font size"
ATTR "Font style"
ENDGROUP
ATTR "Description" lines:5
ATTR "Comment" lines:5
CHAPTER "Object display"
ATTR "Color" dialog:color
ATTR "Lines"
CHAPTER "Deutsch"
GROUP "Aggregation"
ATTR "Bezeichnung"
ATTR "Beschreibung" lines:5
ATTR "Kommentar" lines:5
ENDGROUP
#-----
LANG "de"
#-----
CHAPTER "Beschreibung (deutsch)"
GROUP "Aggregation"
ATTR "Bezeichnung"
ATTR "Beschreibung" lines:5
ATTR "Kommentar" lines:5
ENDGROUP
CHAPTER "Beschreibung"
ATTR "Name"
GROUP "Name display"
ATTR "Display name" ctrltype:check checked-value:"Yes" unchecked-value:"No"
ATTR "Representation"
ATTR "Font size"
ATTR "Font style"
ENDGROUP
ATTR "Description" lines:5
ATTR "Comment" lines:5
CHAPTER "Objektanzeige"
ATTR "Color" dialog:color
ATTR "Lines"
```

1.2.38 Class "Note"

ADONIS BPMS WE Library 3.9:

```

NOTEBOOK
#-----
LANG "en"
#-----
CHAPTER "Description"
ATTR "Text" lines:15
ATTR "Font size"
ATTR "Font style"
ATTR "Color" dialog:color
ATTR "External graphic"
ATTR "Calculate size of graphic automatically" ctrltype:check checked-value:"Yes"
unchecked-value:"No"
CHAPTER "Deutsch"
ATTR "Notiz" lines:15
#-----
LANG "de"
#-----
CHAPTER "Beschreibung (deutsch)"
ATTR "Notiz" lines:15
CHAPTER "Beschreibung"
ATTR "Text" lines:15
ATTR "Font size"
ATTR "Font style"
ATTR "Color" dialog:color
ATTR "External graphic"
ATTR "Calculate size of graphic automatically" ctrltype:check checked-value:"Yes"
unchecked-value:"No"

```

1.2.39 Class "Swimlane (horizontal)"

ADONIS BPMS WE Library 3.9:

```

NOTEBOOK
#-----
LANG "en"
#-----
CHAPTER "Description"
ATTR "Name"
#ATTR "Working environment"
ATTR "Description" lines:5
ATTR "Comment" lines:5
ATTR "Open questions" lines:5
CHAPTER "Representation"
GROUP "Swimlane"
ATTR "Color" dialog:color
ATTR "Display water marks" ctrltype:check unchecked-value:"no" checked-value:"yes"
ENDGROUP
GROUP "Text"
ATTR "Alignment" ctrltype:dropdown
ENDGROUP
CHAPTER "Deutsch"
GROUP "Schwimmbahn"
ATTR "Bezeichnung"
ATTR "Beschreibung" lines:5
ATTR "Kommentar" lines:5

```

Part IV

```
ENDGROUP
#-----
LANG "de"
#-----
CHAPTER "Beschreibung (deutsch)"
GROUP "Schwimmbahn"
ATTR "Bezeichnung"
ATTR "Beschreibung" lines:5
ATTR "Kommentar" lines:5
ENDGROUP
CHAPTER "Beschreibung"
ATTR "Name"
#ATTR "Working environment"
ATTR "Description" lines:5
ATTR "Comment" lines:5
ATTR "Open questions" lines:5
CHAPTER "Darstellung"
GROUP "Swimlane"
ATTR "Color" dialog:color
ATTR "Display water marks" ctrltype:check unchecked-value:"no" checked-value:"yes"
ENDGROUP
GROUP "Text"
ATTR "Alignment" ctrltype:dropdown
ENDGROUP
```

1.2.40 Class "Swimlane (vertical)"

ADONIS BPMS WE Library 3.9:

```
NOTEBOOK
#-----
LANG "en"
#-----
CHAPTER "Description"
ATTR "Name"
#ATTR "Working environment"
ATTR "Description" lines:5
ATTR "Comment" lines:5
ATTR "Open questions" lines:5
CHAPTER "Representation"
GROUP "Swimlane"
ATTR "Color" dialog:color
ATTR "Display water marks" ctrltype:check unchecked-value:"no" checked-value:"yes"
ENDGROUP
GROUP "Text"
ATTR "Alignment" ctrltype:dropdown
ENDGROUP
CHAPTER "Deutsch"
GROUP "Schwimmbahn"
ATTR "Bezeichnung"
ATTR "Beschreibung" lines:5
ATTR "Kommentar" lines:5
ENDGROUP
#-----
LANG "de"
#-----
CHAPTER "Beschreibung (deutsch)"
GROUP "Schwimmbahn"
ATTR "Bezeichnung"
```

```

ATTR "Beschreibung" lines:5
ATTR "Kommentar" lines:5
ENDGROUP
CHAPTER "Beschreibung"
ATTR "Name"
#ATTR "Working environment"
ATTR "Description" lines:5
ATTR "Comment" lines:5
ATTR "Open questions" lines:5
CHAPTER "Darstellung"
GROUP "Swimlane"
ATTR "Color" dialog:color
ATTR "Display water marks" ctrltype:check unchecked-value:"no" checked-value:"yes"
ENDGROUP
GROUP "Text"
ATTR "Alignment" ctrltype:dropdown
ENDGROUP

```

1.2.41 Relation class "Subsequent"

ADONIS BPMS BP Library 3.9:

```

NOTEBOOK
#-----
LANG "en"
#-----
CHAPTER "Description"
ATTR "Denomination"
ATTR "Description" lines:5
ATTR "Comment" lines:5
GROUP "View"
ATTR "Visualized values" ctrltype:dropdown
ATTR "Representation"
ATTR "Font colour"
ENDGROUP
CHAPTER "Details"
GROUP "Simulation"
ATTR "Transition condition" dialog:transcond
ENDGROUP
GROUP "Analytical evaluation"
ATTR "Transition probability"
ENDGROUP
CHAPTER "Deutsch"
GROUP "Nachfolger"
ATTR "Info zur Übergangsbedingung"
ENDGROUP
GROUP "Charakteristika"
ATTR "Bezeichnung"
ATTR "Beschreibung" lines:5
ATTR "Kommentar" lines:5
ENDGROUP
#-----
LANG "de"
#-----
CHAPTER "Beschreibung (deutsch)"
GROUP "Nachfolger"
ATTR "Info zur Übergangsbedingung"
ENDGROUP
GROUP "Charakteristika"

```

Part IV

```
ATTR "Bezeichnung"
ATTR "Beschreibung" lines:5
ATTR "Kommentar" lines:5
ENDGROUP
CHAPTER "Beschreibung"
ATTR "Denomination"
ATTR "Description" lines:5
ATTR "Comment" lines:5
GROUP "View"
ATTR "Visualized values" ctrltype:dropdown
ATTR "Representation"
ATTR "Font colour"
ENDGROUP
CHAPTER "Details"
GROUP "Simulation"
ATTR "Transition condition" dialog:transcond
ENDGROUP
GROUP "Analytical evaluation"
ATTR "Transition probability"
ENDGROUP
```

1.2.42 Relation class "Parameter"

ADONIS BPMS BP Library 3.9:

```
NOTEBOOK
#-----
LANG "en"
#-----
CHAPTER "Description"
ATTR "Index"
#-----
LANG "de"
#-----
CHAPTER "Beschreibung"
ATTR "Index"
```

1.2.43 Relation class "Call parameter"

ADONIS BPMS BP Library 3.9:

```
NOTEBOOK
#-----
LANG "en"
#-----
CHAPTER "Description"
ATTR "Index"
#-----
LANG "de"
#-----
CHAPTER "Beschreibung"
ATTR "Index"
```

1.2.44 Relation class "communicates"

ADONIS BPMS BP Library 3.9:

```

NOTEBOOK
#-----
LANG "en"
#-----
CHAPTER "Description"
ATTR "Name"
ATTR "Description" lines:5
ATTR "Comment" lines:5
CHAPTER "Deutsch"
GROUP "Kommuniziert"
ATTR "Bezeichnung"
ATTR "Beschreibung" lines:5
ATTR "Kommentar" lines:5
ENDGROUP
#-----
LANG "de"
#-----
CHAPTER "Beschreibung (deutsch)"
GROUP "Kommuniziert"
ATTR "Bezeichnung"
ATTR "Beschreibung" lines:5
ATTR "Kommentar" lines:5
ENDGROUP
CHAPTER "Beschreibung"
ATTR "Name"
ATTR "Description" lines:5
ATTR "Comment" lines:5

```

1.2.45 Relation class "Value flow"

ADONIS BPMS BP Library 3.9:

```

NOTEBOOK
#-----
LANG "en"
#-----
CHAPTER "Description"
ATTR "Type"
#-----
LANG "de"
#-----
CHAPTER "Beschreibung"
ATTR "Type"

```

1.2.46 Relation class "Generalisation"

ADONIS BPMS BP Library 3.9:

```

NOTEBOOK
#-----
LANG "en"
#-----
CHAPTER "Description"
ATTR "Name"
ATTR "Description" lines:5
ATTR "Comment" lines:5
CHAPTER "Deutsch"
GROUP "Generalisierung"

```

Part IV

```
ATTR "Bezeichnung"
ATTR "Beschreibung" lines:5
ATTR "Kommentar" lines:5
ENDGROUP
#-----
LANG "de"
#-----
CHAPTER "Beschreibung (deutsch)"
GROUP "Generalisierung"
ATTR "Bezeichnung"
ATTR "Beschreibung" lines:5
ATTR "Kommentar" lines:5
ENDGROUP
CHAPTER "Beschreibung"
ATTR "Name"
ATTR "Description" lines:5
ATTR "Comment" lines:5
```

1.2.47 Relation class "contains"

ADONIS BPMS BP Library 3.9:

```
NOTEBOOK
#-----
LANG "en"
#-----
CHAPTER "Description"
ATTR "Name"
ATTR "Description" lines:5
ATTR "Comment" lines:5
CHAPTER "Deutsch"
GROUP "Beinhaltet"
ATTR "Bezeichnung"
ATTR "Beschreibung" lines:5
ATTR "Kommentar" lines:5
ENDGROUP
#-----
LANG "de"
#-----
CHAPTER "Beschreibung (deutsch)"
GROUP "Beinhaltet"
ATTR "Bezeichnung"
ATTR "Beschreibung" lines:5
ATTR "Kommentar" lines:5
ENDGROUP
CHAPTER "Beschreibung"
ATTR "Name"
ATTR "Description" lines:5
ATTR "Comment" lines:5
```

1.2.48 Relation class "extends"

ADONIS BPMS BP Library 3.9:

```
NOTEBOOK
#-----
LANG "en"
#-----
```



```

CHAPTER "Description"
ATTR "Name"
ATTR "Description" lines:5
ATTR "Comment" lines:5
CHAPTER "Deutsch"
GROUP "Erweitert"
ATTR "Bezeichnung"
ATTR "Beschreibung" lines:5
ATTR "Kommentar" lines:5
ENDGROUP
#-----
LANG "de"
#-----
CHAPTER "Beschreibung (deutsch) "
GROUP "Erweitert"
ATTR "Bezeichnung"
ATTR "Beschreibung" lines:5
ATTR "Kommentar" lines:5
ENDGROUP
CHAPTER "Beschreibung"
ATTR "Name"
ATTR "Description" lines:5
ATTR "Comment" lines:5

```

1.2.49 Relation class "uses"

ADONIS BPMS BP Library 3.9:

```

NOTEBOOK
#-----
LANG "en"
#-----
CHAPTER "Description"
ATTR "Name"
ATTR "Description" lines:5
ATTR "Comment" lines:5
CHAPTER "Deutsch"
GROUP "Benutzt"
ATTR "Bezeichnung"
ATTR "Beschreibung" lines:5
ATTR "Kommentar" lines:5
ENDGROUP
#-----
LANG "de"
#-----
CHAPTER "Beschreibung (deutsch) "
GROUP "Benutzt"
ATTR "Bezeichnung"
ATTR "Beschreibung" lines:5
ATTR "Kommentar" lines:5
ENDGROUP
CHAPTER "Beschreibung"
ATTR "Name"
ATTR "Description" lines:5
ATTR "Comment" lines:5

```

1.2.50 Relation class "Has process"

ADONIS BPMS BP Library 3.9:

```
NOTEBOOK
#-----
LANG "en"
#-----
CHAPTER "Description"
ATTR "Name"
GROUP "View"
ATTR "Representation"
ATTR "Fontcolor"
ENDGROUP
CHAPTER "Deutsch"
ATTR "Bezeichnung"
#-----
LANG "de"
#-----
CHAPTER "Beschreibung (deutsch)"
ATTR "Bezeichnung"
CHAPTER "Beschreibung"
ATTR "Name"
GROUP "View"
ATTR "Representation"
ATTR "Fontcolor"
ENDGROUP
```

1.2.51 Relation class "has "

ADONIS BPMS BP Library 3.9:

```
NOTEBOOK
#-----
LANG "en"
#-----
CHAPTER "Description"
ATTR "Bezeichnung"
ATTR "Representation"
ATTR "Fontcolor"
ATTR "Description"
ATTR "Comment"
CHAPTER "Deutsch"
ATTR "Bezeichnung"
ATTR "Beschreibung"
ATTR "Kommentar"
#-----
LANG "de"
#-----
CHAPTER "Beschreibung (deutsch)"
ATTR "Bezeichnung"
ATTR "Beschreibung"
ATTR "Kommentar"
CHAPTER "Beschreibung"
ATTR "Bezeichnung"
ATTR "Representation"
ATTR "Fontcolor"
ATTR "Description"
ATTR "Comment "
```

1.2.52 Relation class "has"

ADONIS BPMS BP Library 3.9:

```

NOTEBOOK
#-----
LANG "en"
#-----
CHAPTER "Description"
ATTR "Name"
ATTR "Representation"
ATTR "Fontcolor"
ATTR "Description"
ATTR "Comment"
CHAPTER "Deutsch"
ATTR "Bezeichnung"
ATTR "Beschreibung"
ATTR "Kommentar"
#-----
LANG "de"
#-----
CHAPTER "Beschreibung (deutsch) "
ATTR "Bezeichnung"
ATTR "Beschreibung"
ATTR "Kommentar"
CHAPTER "Beschreibung"
ATTR "Name"
ATTR "Representation"
ATTR "Fontcolor"
ATTR "Description"
ATTR "Comment"

```

1.2.53 Relation class "uses "

ADONIS BPMS BP Library 3.9:

```

NOTEBOOK
#-----
LANG "en"
#-----
CHAPTER "Description"
ATTR "Name"
ATTR "Representation"
ATTR "Fontcolor"
ATTR "Description"
ATTR "Comment"
CHAPTER "Deutsch"
ATTR "Bezeichnung"
ATTR "Beschreibung"
ATTR "Kommentar"
#-----
LANG "de"
#-----
CHAPTER "Beschreibung (deutsch) "
ATTR "Bezeichnung"
ATTR "Beschreibung"
ATTR "Kommentar"
CHAPTER "Beschreibung"
ATTR "Name"

```

Part IV

```
ATTR "Representation"  
ATTR "Fontcolor"  
ATTR "Description"  
ATTR "Comment "
```

1.2.54 Relation class "Is dependent on"

ADONIS BPMS BP Library 3.9:

```
NOTEBOOK  
#-----  
LANG "en"  
#-----  
CHAPTER "Description"  
ATTR "Name"  
ATTR "Representation"  
ATTR "Fontcolor"  
ATTR "Description"  
ATTR "Comment "  
CHAPTER "Deutsch"  
ATTR "Bezeichnung"  
ATTR "Beschreibung"  
ATTR "Kommentar"  
#-----  
LANG "de"  
#-----  
CHAPTER "Beschreibung (deutsch) "  
ATTR "Bezeichnung"  
ATTR "Beschreibung"  
ATTR "Kommentar"  
CHAPTER "Beschreibung"  
ATTR "Name"  
ATTR "Representation"  
ATTR "Fontcolor"  
ATTR "Description"  
ATTR "Comment "
```











1.2.55 Relation class "Is subordinated"

ADONIS BPMS WE Library 3.9:

```
#-----  
LANG "en"  
#-----  
CHAPTER "Description"  
ATTR "Representation"  
#-----  
LANG "de"  
#-----  
CHAPTER "Beschreibung"  
ATTR "Representation"
```

1.3 Model pointer

The class attribute "Model pointer" is defined for the following **Classes of the ADONIS BPMS BP Library 3.9:**

-  use case (see chap. 1.3.1, p. 451)
-  Subprocess (see chap. 1.3.2, p. 451)
-  Process (see chap. 1.3.3, p. 451)
-  Document (see chap. 1.3.4, p. 452)
-  Product (see chap. 1.3.5, p. 452)
-  Product component (see chap. 1.3.6, p. 452)
-  Application (see chap. 1.3.7, p. 452)
-  Service (see chap. 1.3.8, p. 452)
-  Performance (see chap. 1.3.9, p. 452)
-  Infrastructure element (see chap. 1.3.10, p. 452)
-  Cross-reference (see chap. 1.3.11, p. 452)

Hint: The class attribute "Model pointer" is not defined for the **Relation classes of the ADONIS BPMS BP Library 3.9.**

The class attribute "Model pointer" is defined for the following **Classes of the ADONIS BPMS WE Library 3.9:**

-  **Organizational unit** (see chap. 1.3.12, p. 453)

Hint: The class attribute "Model pointer" is not defined for the **Relation classes of the ADONIS BPMS WE Library 3.9.**

1.3.1 Class "use case"

ADONIS BPMS BP Library 3.9:

Details

1.3.2 Class "Subprocess"

ADONIS BPMS BP Library 3.9:

Referenced subprocess

1.3.3 Class "Process"

ADONIS BPMS BP Library 3.9:

Referenced process

1.3.4 Class "Document"

ADONIS BPMS BP Library 3.9:

Referenced document model

1.3.5 Class "Product"

ADONIS BPMS BP Library 3.9:

Referenced product model

1.3.6 Class "Product component"

ADONIS BPMS BP Library 3.9:

Referenced product model

1.3.7 Class "Application"

ADONIS BPMS BP Library 3.9:

Referenced IT system model

1.3.8 Class "Service"

ADONIS BPMS BP Library 3.9:

Referenced IT system model

1.3.9 Class "Performance"

ADONIS BPMS BP Library 3.9:

Referenced element

1.3.10 Class "Infrastructure element"

ADONIS BPMS BP Library 3.9:

Referenced IT system model

1.3.11 Class "Cross-reference"

ADONIS BPMS BP Library 3.9:

Cross-reference



























1.3.12 Class "Organizational unit"

ADONIS BPMS WE Library 3.9:

Model reference

1.4 Class cardinality

The class attribute "Class cardinality" is defined for the following **Classes of the ADONIS BPMS BP Library 3.9:**

	actor (see chap. 1.4.1, p. 454)
	use case (see chap. 1.4.2, p. 456)
	system boundary (see chap. 1.4.3, p. 458)
	Trigger (see chap. 1.4.4, p. 460)
	Process start (see chap. 1.4.5, p. 462)
	Subprocess (see chap. 1.4.6, p. 464)
	Activity (see chap. 1.4.7, p. 467)
	Decision (see chap. 1.4.8, p. 469)
	Parallellity (see chap. 1.4.9, p. 471)
	Merging (see chap. 1.4.10, p. 473)
	End (see chap. 1.4.11, p. 475)
	Variable (see chap. 1.4.12, p. 478)
	Random generator (see chap. 1.4.13, p. 480)
	Resource (see chap. 1.4.14, p. 482)
	Process (see chap. 1.4.15, p. 484)
	Performance indicator overview (see chap. 1.4.16, p. 486)
	Performance indicator (see chap. 1.4.17, p. 488)
	Document (see chap. 1.4.18, p. 490)
	Note (see chap. 1.4.19, p. 493)
	Aggregation (see chap. 1.4.20, p. 495)
	External partner (see chap. 1.4.21, p. 497)
	Product (see chap. 1.4.22, p. 499)
	Product component (see chap. 1.4.23, p. 501)
	Application (see chap. 1.4.24, p. 503)
	Service (see chap. 1.4.25, p. 505)
	Performance (see chap. 1.4.26, p. 507)
	Infrastructure element (see chap. 1.4.27, p. 509)

Hint: The class attribute "Class cardinality" is not defined for the **Relation classes of the ADONIS BPMS BP Library 3.9.**

The class attribute "Class cardinality" is defined for the following **Classes of the ADONIS BPMS WE Library 3.9:**



Cost center (see chap. 1.4.28, p. 512)

Hint: The class attribute "Class cardinality" is not defined for the **Relation classes of the ADONIS BPMS WE Library 3.9.**

1.4.1 Class "actor"

ADONIS BPMS BP Library 3.9:

```
CARDINALITIES
RELATION "has Cross-reference"
FROM_CLASS "Cross-reference"
max-incoming:1000
TO_CLASS "Cross-reference"
max-outgoing:1000
FROM_CLASS "Trigger"
max-incoming:0
TO_CLASS "Trigger"
max-outgoing:0
FROM_CLASS "Process start"
max-incoming:0
TO_CLASS "Process start"
max-outgoing:0
FROM_CLASS "Subprocess"
max-incoming:0
TO_CLASS "Subprocess"
max-outgoing:0
FROM_CLASS "Activity"
max-incoming:0
TO_CLASS "Activity"
max-outgoing:0
FROM_CLASS "Decision"
max-incoming:0
TO_CLASS "Decision"
max-outgoing:0
FROM_CLASS "Parallellity"
max-incoming:0
TO_CLASS "Parallellity"
max-outgoing:0
FROM_CLASS "Merging"
max-incoming:0
TO_CLASS "Merging"
max-outgoing:0
FROM_CLASS "End"
max-incoming:0
TO_CLASS "End"
max-outgoing:0
FROM_CLASS "Variable"
max-incoming:0
TO_CLASS "Variable"
max-outgoing:0
FROM_CLASS "Random generator"
max-incoming:0
TO_CLASS "Random generator"
```



```
max-outgoing:0
FROM_CLASS "Resource"
max-incoming:0
TO_CLASS "Resource"
max-outgoing:0
FROM_CLASS "Performance indicator overview"
max-incoming:0
TO_CLASS "Performance indicator overview"
max-outgoing:0
FROM_CLASS "Performance indicator"
max-incoming:0
TO_CLASS "Performance indicator"
max-outgoing:0
FROM_CLASS "Note"
max-incoming:0
TO_CLASS "Note"
max-outgoing:0
FROM_CLASS "Aggregation"
max-incoming:0
TO_CLASS "Aggregation"
max-outgoing:0
FROM_CLASS "Document"
max-incoming:0
TO_CLASS "Document"
max-outgoing:0
FROM_CLASS "Document"
max-incoming:0
TO_CLASS "Document"
max-outgoing:0
FROM_CLASS "actor"
max-incoming:0
TO_CLASS "actor"
max-outgoing:0
FROM_CLASS "use case"
max-incoming:0
TO_CLASS "use case"
max-outgoing:0
FROM_CLASS "system boundary"
max-incoming:0
TO_CLASS "system boundary"
max-outgoing:0
FROM_CLASS "system boundary"
max-incoming:0
TO_CLASS "system boundary"
max-outgoing:0
FROM_CLASS "Process"
max-incoming:0
TO_CLASS "Process"
max-outgoing:0
FROM_CLASS "Performance"
max-incoming:0
TO_CLASS "Performance"
max-outgoing:0
FROM_CLASS "External partner"
max-incoming:0
TO_CLASS "External partner"
max-outgoing:0
FROM_CLASS "Product"
max-incoming:0
TO_CLASS "Product"
max-outgoing:0
```

Part IV

```
FROM_CLASS "Product component"  
max-incoming:0  
TO_CLASS "Product component"  
max-outgoing:0  
FROM_CLASS "Application"  
max-incoming:0  
TO_CLASS "Application"  
max-outgoing:0  
FROM_CLASS "Service"  
max-incoming:0  
TO_CLASS "Service"  
max-outgoing:0  
FROM_CLASS "Infrastructure element"  
max-incoming:0  
TO_CLASS "Infrastructure element"  
max-outgoing:0
```

1.4.2 Class "use case"

ADONIS BPMS BP Library 3.9:

```
CARDINALITIES  
RELATION "has Cross-reference"  
FROM_CLASS "Cross-reference"  
max-incoming:1000  
TO_CLASS "Cross-reference"  
max-outgoing:1000  
FROM_CLASS "Trigger"  
max-incoming:0  
TO_CLASS "Trigger"  
max-outgoing:0  
FROM_CLASS "Process start"  
max-incoming:0  
TO_CLASS "Process start"  
max-outgoing:0  
FROM_CLASS "Subprocess"  
max-incoming:0  
TO_CLASS "Subprocess"  
max-outgoing:0  
FROM_CLASS "Activity"  
max-incoming:0  
TO_CLASS "Activity"  
max-outgoing:0  
FROM_CLASS "Decision"  
max-incoming:0  
TO_CLASS "Decision"  
max-outgoing:0  
FROM_CLASS "Parallellity"  
max-incoming:0  
TO_CLASS "Parallellity"  
max-outgoing:0  
FROM_CLASS "Merging"  
max-incoming:0  
TO_CLASS "Merging"  
max-outgoing:0  
FROM_CLASS "End"  
max-incoming:0  
TO_CLASS "End"  
max-outgoing:0
```

```

FROM_CLASS "Variable"
max-incoming:0
TO_CLASS "Variable"
max-outgoing:0
FROM_CLASS "Random generator"
max-incoming:0
TO_CLASS "Random generator"
max-outgoing:0
FROM_CLASS "Resource"
max-incoming:0
TO_CLASS "Resource"
max-outgoing:0
FROM_CLASS "Performance indicator overview"
max-incoming:0
TO_CLASS "Performance indicator overview"
max-outgoing:0
FROM_CLASS "Performance indicator"
max-incoming:0
TO_CLASS "Performance indicator"
max-outgoing:0
FROM_CLASS "Note"
max-incoming:0
TO_CLASS "Note"
max-outgoing:0
FROM_CLASS "Aggregation"
max-incoming:0
TO_CLASS "Aggregation"
max-outgoing:0
FROM_CLASS "Document"
max-incoming:0
TO_CLASS "Document"
max-outgoing:0
FROM_CLASS "Document"
max-incoming:0
TO_CLASS "Document"
max-outgoing:0
FROM_CLASS "actor"
max-incoming:0
TO_CLASS "actor"
max-outgoing:0
FROM_CLASS "use case"
max-incoming:0
TO_CLASS "use case"
max-outgoing:0
FROM_CLASS "system boundary"
max-incoming:0
TO_CLASS "system boundary"
max-outgoing:0
FROM_CLASS "system boundary"
max-incoming:0
TO_CLASS "system boundary"
max-outgoing:0
FROM_CLASS "Process"
max-incoming:0
TO_CLASS "Process"
max-outgoing:0
FROM_CLASS "Performance"
max-incoming:0
TO_CLASS "Performance"
max-outgoing:0
FROM_CLASS "External partner"

```

Part IV

```
max-incoming:0
TO_CLASS "External partner"
max-outgoing:0
FROM_CLASS "Product"
max-incoming:0
TO_CLASS "Product"
max-outgoing:0
FROM_CLASS "Product component"
max-incoming:0
TO_CLASS "Product component"
max-outgoing:0
FROM_CLASS "Application"
max-incoming:0
TO_CLASS "Application"
max-outgoing:0
FROM_CLASS "Service"
max-incoming:0
TO_CLASS "Service"
max-outgoing:0
FROM_CLASS "Infrastructure element"
max-incoming:0
TO_CLASS "Infrastructure element"
max-outgoing:0
```

1.4.3 Class "system boundary"

ADONIS BPMS BP Library 3.9:

```
CARDINALITIES
RELATION "has Cross-reference"
FROM_CLASS "Cross-reference"
max-incoming:1000
TO_CLASS "Cross-reference"
max-outgoing:1000
FROM_CLASS "Trigger"
max-incoming:0
TO_CLASS "Trigger"
max-outgoing:0
FROM_CLASS "Process start"
max-incoming:0
TO_CLASS "Process start"
max-outgoing:0
FROM_CLASS "Subprocess"
max-incoming:0
TO_CLASS "Subprocess"
max-outgoing:0
FROM_CLASS "Activity"
max-incoming:0
TO_CLASS "Activity"
max-outgoing:0
FROM_CLASS "Decision"
max-incoming:0
TO_CLASS "Decision"
max-outgoing:0
FROM_CLASS "Parallelity"
max-incoming:0
TO_CLASS "Parallelity"
max-outgoing:0
FROM_CLASS "Merging"
```

```
max-incoming:0
TO_CLASS "Merging"
max-outgoing:0
FROM_CLASS "End"
max-incoming:0
TO_CLASS "End"
max-outgoing:0
FROM_CLASS "Variable"
max-incoming:0
TO_CLASS "Variable"
max-outgoing:0
FROM_CLASS "Random generator"
max-incoming:0
TO_CLASS "Random generator"
max-outgoing:0
FROM_CLASS "Resource"
max-incoming:0
TO_CLASS "Resource"
max-outgoing:0
FROM_CLASS "Performance indicator overview"
max-incoming:0
TO_CLASS "Performance indicator overview"
max-outgoing:0
FROM_CLASS "Performance indicator"
max-incoming:0
TO_CLASS "Performance indicator"
max-outgoing:0
FROM_CLASS "Note"
max-incoming:0
TO_CLASS "Note"
max-outgoing:0
FROM_CLASS "Aggregation"
max-incoming:0
TO_CLASS "Aggregation"
max-outgoing:0
FROM_CLASS "Document"
max-incoming:0
TO_CLASS "Document"
max-outgoing:0
FROM_CLASS "Document"
max-incoming:0
TO_CLASS "Document"
max-outgoing:0
FROM_CLASS "actor"
max-incoming:0
TO_CLASS "actor"
max-outgoing:0
FROM_CLASS "use case"
max-incoming:0
TO_CLASS "use case"
max-outgoing:0
FROM_CLASS "system boundary"
max-incoming:0
TO_CLASS "system boundary"
max-outgoing:0
FROM_CLASS "system boundary"
max-incoming:0
TO_CLASS "system boundary"
max-outgoing:0
FROM_CLASS "Process"
max-incoming:0
```

Part IV

```
TO_CLASS "Process"
max-outgoing:0
FROM_CLASS "Performance"
max-incoming:0
TO_CLASS "Performance"
max-outgoing:0
FROM_CLASS "External partner"
max-incoming:0
TO_CLASS "External partner"
max-outgoing:0
FROM_CLASS "Product"
max-incoming:0
TO_CLASS "Product"
max-outgoing:0
FROM_CLASS "Product component"
max-incoming:0
TO_CLASS "Product component"
max-outgoing:0
FROM_CLASS "Application"
max-incoming:0
TO_CLASS "Application"
max-outgoing:0
FROM_CLASS "Service"
max-incoming:0
TO_CLASS "Service"
max-outgoing:0
FROM_CLASS "Infrastructure element"
max-incoming:0
TO_CLASS "Infrastructure element"
max-outgoing:0
```

1.4.4 Class "Trigger"

ADONIS BPMS BP Library 3.9:

```
CARDINALITIES
max-incoming:0
RELATION "has Cross-reference"
FROM_CLASS "Cross-reference"
max-incoming:1000
TO_CLASS "Cross-reference"
max-outgoing:1000
FROM_CLASS "Trigger"
max-incoming:0
TO_CLASS "Trigger"
max-outgoing:0
FROM_CLASS "Process start"
max-incoming:0
TO_CLASS "Process start"
max-outgoing:0
FROM_CLASS "Subprocess"
max-incoming:0
TO_CLASS "Subprocess"
max-outgoing:0
FROM_CLASS "Activity"
max-incoming:0
TO_CLASS "Activity"
max-outgoing:0
FROM_CLASS "Decision"
```

```
max-incoming:0
TO_CLASS "Decision"
max-outgoing:0
FROM_CLASS "Parallellity"
max-incoming:0
TO_CLASS "Parallellity"
max-outgoing:0
FROM_CLASS "Merging"
max-incoming:0
TO_CLASS "Merging"
max-outgoing:0
FROM_CLASS "End"
max-incoming:0
TO_CLASS "End"
max-outgoing:0
FROM_CLASS "Variable"
max-incoming:0
TO_CLASS "Variable"
max-outgoing:0
FROM_CLASS "Random generator"
max-incoming:0
TO_CLASS "Random generator"
max-outgoing:0
FROM_CLASS "Resource"
max-incoming:0
TO_CLASS "Resource"
max-outgoing:0
FROM_CLASS "Performance indicator overview"
max-incoming:0
TO_CLASS "Performance indicator overview"
max-outgoing:0
FROM_CLASS "Performance indicator"
max-incoming:0
TO_CLASS "Performance indicator"
max-outgoing:0
FROM_CLASS "Note"
max-incoming:0
TO_CLASS "Note"
max-outgoing:0
FROM_CLASS "Aggregation"
max-incoming:0
TO_CLASS "Aggregation"
max-outgoing:0
FROM_CLASS "Document"
max-incoming:0
TO_CLASS "Document"
max-outgoing:0
FROM_CLASS "Document"
max-incoming:0
TO_CLASS "Document"
max-outgoing:0
FROM_CLASS "actor"
max-incoming:0
TO_CLASS "actor"
max-outgoing:0
FROM_CLASS "use case"
max-incoming:0
TO_CLASS "use case"
max-outgoing:0
FROM_CLASS "system boundary"
max-incoming:0
```

Part IV

```
TO_CLASS "system boundary"
max-outgoing:0
FROM_CLASS "system boundary"
max-incoming:0
TO_CLASS "system boundary"
max-outgoing:0
FROM_CLASS "Process"
max-incoming:0
TO_CLASS "Process"
max-outgoing:0
FROM_CLASS "Performance"
max-incoming:0
TO_CLASS "Performance"
max-outgoing:0
FROM_CLASS "External partner"
max-incoming:0
TO_CLASS "External partner"
max-outgoing:0
FROM_CLASS "Product"
max-incoming:0
TO_CLASS "Product"
max-outgoing:0
FROM_CLASS "Product component"
max-incoming:0
TO_CLASS "Product component"
max-outgoing:0
FROM_CLASS "Application"
max-incoming:0
TO_CLASS "Application"
max-outgoing:0
FROM_CLASS "Service"
max-incoming:0
TO_CLASS "Service"
max-outgoing:0
FROM_CLASS "Infrastructure element"
max-incoming:0
TO_CLASS "Infrastructure element"
max-outgoing:0
```

1.4.5 Class "Process start"

ADONIS BPMS BP Library 3.9:

```
CARDINALITIES
max-objects:1
min-objects:1
RELATION "Subsequent"
max-outgoing:1
min-outgoing:1
max-incoming:0
FROM_CLASS "Trigger"
max-incoming:1000
RELATION "has Cross-reference"
FROM_CLASS "Cross-reference"
max-incoming:1000
TO_CLASS "Cross-reference"
max-outgoing:1000
FROM_CLASS "Trigger"
max-incoming:0
```



```

TO_CLASS "Trigger"
max-outgoing:0
FROM_CLASS "Process start"
max-incoming:0
TO_CLASS "Process start"
max-outgoing:0
FROM_CLASS "Subprocess"
max-incoming:0
TO_CLASS "Subprocess"
max-outgoing:0
FROM_CLASS "Activity"
max-incoming:0
TO_CLASS "Activity"
max-outgoing:0
FROM_CLASS "Decision"
max-incoming:0
TO_CLASS "Decision"
max-outgoing:0
FROM_CLASS "Parallellity"
max-incoming:0
TO_CLASS "Parallellity"
max-outgoing:0
FROM_CLASS "Merging"
max-incoming:0
TO_CLASS "Merging"
max-outgoing:0
FROM_CLASS "End"
max-incoming:0
TO_CLASS "End"
max-outgoing:0
FROM_CLASS "Variable"
max-incoming:0
TO_CLASS "Variable"
max-outgoing:0
FROM_CLASS "Random generator"
max-incoming:0
TO_CLASS "Random generator"
max-outgoing:0
FROM_CLASS "Resource"
max-incoming:0
TO_CLASS "Resource"
max-outgoing:0
FROM_CLASS "Performance indicator overview"
max-incoming:0
TO_CLASS "Performance indicator overview"
max-outgoing:0
FROM_CLASS "Performance indicator overview"
max-incoming:0
TO_CLASS "Performance indicator overview"
max-outgoing:0
FROM_CLASS "Note"
max-incoming:0
TO_CLASS "Note"
max-outgoing:0
FROM_CLASS "Aggregation"
max-incoming:0
TO_CLASS "Aggregation"
max-outgoing:0
FROM_CLASS "Document"
max-incoming:0
TO_CLASS "Document"

```

Part IV

```
max-outgoing:0
FROM_CLASS "Document"
max-incoming:0
TO_CLASS "Document"
max-outgoing:0
FROM_CLASS "actor"
max-incoming:0
TO_CLASS "actor"
max-outgoing:0
FROM_CLASS "use case"
max-incoming:0
TO_CLASS "use case"
max-outgoing:0
FROM_CLASS "system boundary"
max-incoming:0
TO_CLASS "system boundary"
max-outgoing:0
FROM_CLASS "system boundary"
max-incoming:0
TO_CLASS "system boundary"
max-outgoing:0
FROM_CLASS "Process"
max-incoming:0
TO_CLASS "Process"
max-outgoing:0
FROM_CLASS "Performance"
max-incoming:0
TO_CLASS "Performance"
max-outgoing:0
FROM_CLASS "External partner"
max-incoming:0
TO_CLASS "External partner"
max-outgoing:0
FROM_CLASS "Product"
max-incoming:0
TO_CLASS "Product"
max-outgoing:0
FROM_CLASS "Product component"
max-incoming:0
TO_CLASS "Product component"
max-outgoing:0
FROM_CLASS "Application"
max-incoming:0
TO_CLASS "Application"
max-outgoing:0
FROM_CLASS "Service"
max-incoming:0
TO_CLASS "Service"
max-outgoing:0
FROM_CLASS "Infrastructure element"
max-incoming:0
TO_CLASS "Infrastructure element"
max-outgoing:0
```

1.4.6 Class "Subprocess"

ADONIS BPMS BP Library 3.9:

CARDINALITIES

```

RELATION "Subsequent"
max-outgoing:1
min-outgoing:1
min-incoming:1
RELATION "has Cross-reference"
FROM_CLASS "Cross-reference"
max-incoming:1000
TO_CLASS "Cross-reference"
max-outgoing:1000
FROM_CLASS "Trigger"
max-incoming:0
TO_CLASS "Trigger"
max-outgoing:0
FROM_CLASS "Process start"
max-incoming:0
TO_CLASS "Process start"
max-outgoing:0
FROM_CLASS "Subprocess"
max-incoming:0
TO_CLASS "Subprocess"
max-outgoing:0
FROM_CLASS "Activity"
max-incoming:0
TO_CLASS "Activity"
max-outgoing:0
FROM_CLASS "Decision"
max-incoming:0
TO_CLASS "Decision"
max-outgoing:0
FROM_CLASS "Parallellity"
max-incoming:0
TO_CLASS "Parallellity"
max-outgoing:0
FROM_CLASS "Merging"
max-incoming:0
TO_CLASS "Merging"
max-outgoing:0
FROM_CLASS "End"
max-incoming:0
TO_CLASS "End"
max-outgoing:0
FROM_CLASS "Variable"
max-incoming:0
TO_CLASS "Variable"
max-outgoing:0
FROM_CLASS "Random generator"
max-incoming:0
TO_CLASS "Random generator"
max-outgoing:0
FROM_CLASS "Resource"
max-incoming:0
TO_CLASS "Resource"
max-outgoing:0
FROM_CLASS "Performance indicator overview"
max-incoming:0
TO_CLASS "Performance indicator overview"
max-outgoing:0
FROM_CLASS "Performance indicator"
max-incoming:0
TO_CLASS "Performance indicator"
max-outgoing:0

```

Part IV

```
FROM_CLASS "Note"
max-incoming:0
TO_CLASS "Note"
max-outgoing:0
FROM_CLASS "Aggregation"
max-incoming:0
TO_CLASS "Aggregation"
max-outgoing:0
FROM_CLASS "Document"
max-incoming:0
TO_CLASS "Document"
max-outgoing:0
FROM_CLASS "Document"
max-incoming:0
TO_CLASS "Document"
max-outgoing:0
FROM_CLASS "actor"
max-incoming:0
TO_CLASS "actor"
max-outgoing:0
FROM_CLASS "use case"
max-incoming:0
TO_CLASS "use case"
max-outgoing:0
FROM_CLASS "system boundary"
max-incoming:0
TO_CLASS "system boundary"
max-outgoing:0
FROM_CLASS "system boundary"
max-incoming:0
TO_CLASS "system boundary"
max-outgoing:0
FROM_CLASS "Process"
max-incoming:0
TO_CLASS "Process"
max-outgoing:0
FROM_CLASS "Performance"
max-incoming:0
TO_CLASS "Performance"
max-outgoing:0
FROM_CLASS "External partner"
max-incoming:0
TO_CLASS "External partner"
max-outgoing:0
FROM_CLASS "Product"
max-incoming:0
TO_CLASS "Product"
max-outgoing:0
FROM_CLASS "Product component"
max-incoming:0
TO_CLASS "Product component"
max-outgoing:0
FROM_CLASS "Application"
max-incoming:0
TO_CLASS "Application"
max-outgoing:0
FROM_CLASS "Service"
max-incoming:0
TO_CLASS "Service"
max-outgoing:0
FROM_CLASS "Infrastructure element"
```

```

max-incoming:0
TO_CLASS "Infrastructure element"
max-outgoing:0

```

1.4.7 Class "Activity"

ADONIS BPMS BP Library 3.9:

```

CARDINALITIES
RELATION "Subsequent"
max-outgoing: 1
min-outgoing:1
min-incoming:1
RELATION "Uses"
max-outgoing: 1
RELATION "has Cross-reference"
FROM_CLASS "Cross-reference"
max-incoming:1000
TO_CLASS "Cross-reference"
max-outgoing:1000
FROM_CLASS "Trigger"
max-incoming:0
TO_CLASS "Trigger"
max-outgoing:0
FROM_CLASS "Process start"
max-incoming:0
TO_CLASS "Process start"
max-outgoing:0
FROM_CLASS "Subprocess"
max-incoming:0
TO_CLASS "Subprocess"
max-outgoing:0
FROM_CLASS "Activity"
max-incoming:0
TO_CLASS "Activity"
max-outgoing:0
FROM_CLASS "Decision"
max-incoming:0
TO_CLASS "Decision"
max-outgoing:0
FROM_CLASS "Parallelity"
max-incoming:0
TO_CLASS "Parallelity"
max-outgoing:0
FROM_CLASS "Merging"
max-incoming:0
TO_CLASS "Merging"
max-outgoing:0
FROM_CLASS "End"
max-incoming:0
TO_CLASS "End"
max-outgoing:0
FROM_CLASS "Variable"
max-incoming:0
TO_CLASS "Variable"
max-outgoing:0
FROM_CLASS "Random generator"
max-incoming:0
TO_CLASS "Random generator"

```

Part IV

```
max-outgoing:0
FROM_CLASS "Resource"
max-incoming:0
TO_CLASS "Resource"
max-outgoing:0
FROM_CLASS "Performance indicator overview"
max-incoming:0
TO_CLASS "Performance indicator overview"
max-outgoing:0
FROM_CLASS "Performance indicator"
max-incoming:0
TO_CLASS "Performance indicator"
max-outgoing:0
FROM_CLASS "Note"
max-incoming:0
TO_CLASS "Note"
max-outgoing:0
FROM_CLASS "Aggregation"
max-incoming:0
TO_CLASS "Aggregation"
max-outgoing:0
FROM_CLASS "Document"
max-incoming:0
TO_CLASS "Document"
max-outgoing:0
FROM_CLASS "Document"
max-incoming:0
TO_CLASS "Document"
max-outgoing:0
FROM_CLASS "actor"
max-incoming:0
TO_CLASS "actor"
max-outgoing:0
FROM_CLASS "use case"
max-incoming:0
TO_CLASS "use case"
max-outgoing:0
FROM_CLASS "system boundary"
max-incoming:0
TO_CLASS "system boundary"
max-outgoing:0
FROM_CLASS "system boundary"
max-incoming:0
TO_CLASS "system boundary"
max-outgoing:0
FROM_CLASS "Process"
max-incoming:0
TO_CLASS "Process"
max-outgoing:0
FROM_CLASS "Performance"
max-incoming:0
TO_CLASS "Performance"
max-outgoing:0
FROM_CLASS "External partner"
max-incoming:0
TO_CLASS "External partner"
max-outgoing:0
FROM_CLASS "Product"
max-incoming:0
TO_CLASS "Product"
max-outgoing:0
```

```

FROM_CLASS "Product component"
max-incoming:0
TO_CLASS "Product component"
max-outgoing:0
FROM_CLASS "Application"
max-incoming:0
TO_CLASS "Application"
max-outgoing:0
FROM_CLASS "Service"
max-incoming:0
TO_CLASS "Service"
max-outgoing:0
FROM_CLASS "Infrastructure element"
max-incoming:0
TO_CLASS "Infrastructure element"
max-outgoing:0

```

1.4.8 Class "Decision"

ADONIS BPMS BP Library 3.9:

```

CARDINALITIES
RELATION "Subsequent"
min-outgoing:2
min-incoming:1
RELATION "has Cross-reference"
FROM_CLASS "Cross-reference"
max-incoming:1000
TO_CLASS "Cross-reference"
max-outgoing:1000
FROM_CLASS "Trigger"
max-incoming:0
TO_CLASS "Trigger"
max-outgoing:0
FROM_CLASS "Process start"
max-incoming:0
TO_CLASS "Process start"
max-outgoing:0
FROM_CLASS "Subprocess"
max-incoming:0
TO_CLASS "Subprocess"
max-outgoing:0
FROM_CLASS "Activity"
max-incoming:0
TO_CLASS "Activity"
max-outgoing:0
FROM_CLASS "Decision"
max-incoming:0
TO_CLASS "Decision"
max-outgoing:0
FROM_CLASS "Parallellity"
max-incoming:0
TO_CLASS "Parallellity"
max-outgoing:0
FROM_CLASS "Merging"
max-incoming:0
TO_CLASS "Merging"
max-outgoing:0
FROM_CLASS "End"

```

Part IV

```
max-incoming:0
TO_CLASS "End"
max-outgoing:0
FROM_CLASS "Variable"
max-incoming:0
TO_CLASS "Variable"
max-outgoing:0
FROM_CLASS "Random generator"
max-incoming:0
TO_CLASS "Random generator"
max-outgoing:0
FROM_CLASS "Resource"
max-incoming:0
TO_CLASS "Resource"
max-outgoing:0
FROM_CLASS "Performance indicator overview"
max-incoming:0
TO_CLASS "Performance indicator overview"
max-outgoing:0
FROM_CLASS "Performance indicator"
max-incoming:0
TO_CLASS "Performance indicator"
max-outgoing:0
FROM_CLASS "Note"
max-incoming:0
TO_CLASS "Note"
max-outgoing:0
FROM_CLASS "Aggregation"
max-incoming:0
TO_CLASS "Aggregation"
max-outgoing:0
FROM_CLASS "Document"
max-incoming:0
TO_CLASS "Document"
max-outgoing:0
FROM_CLASS "Document"
max-incoming:0
TO_CLASS "Document"
max-outgoing:0
FROM_CLASS "actor"
max-incoming:0
TO_CLASS "actor"
max-outgoing:0
FROM_CLASS "use case"
max-incoming:0
TO_CLASS "use case"
max-outgoing:0
FROM_CLASS "system boundary"
max-incoming:0
TO_CLASS "system boundary"
max-outgoing:0
FROM_CLASS "system boundary"
max-incoming:0
TO_CLASS "system boundary"
max-outgoing:0
FROM_CLASS "Process"
max-incoming:0
TO_CLASS "Process"
max-outgoing:0
FROM_CLASS "Performance"
max-incoming:0
```



```

TO_CLASS "Performance"
max-outgoing:0
FROM_CLASS "External partner"
max-incoming:0
TO_CLASS "External partner"
max-outgoing:0
FROM_CLASS "Product"
max-incoming:0
TO_CLASS "Product"
max-outgoing:0
FROM_CLASS "Product component"
max-incoming:0
TO_CLASS "Product component"
max-outgoing:0
FROM_CLASS "Application"
max-incoming:0
TO_CLASS "Application"
max-outgoing:0
FROM_CLASS "Service"
max-incoming:0
TO_CLASS "Service"
max-outgoing:0
FROM_CLASS "Infrastructure element"
max-incoming:0
TO_CLASS "Infrastructure element"
max-outgoing:0

```

1.4.9 Class "Parallelity"

ADONIS BPMS BP Library 3.9:

```

CARDINALITIES
RELATION "Subsequent"
min-outgoing:2
min-incoming:1
RELATION "has Cross-reference"
FROM_CLASS "Cross-reference"
max-incoming:1000
TO_CLASS "Cross-reference"
max-outgoing:1000
FROM_CLASS "Trigger"
max-incoming:0
TO_CLASS "Trigger"
max-outgoing:0
FROM_CLASS "Process start"
max-incoming:0
TO_CLASS "Process start"
max-outgoing:0
FROM_CLASS "Subprocess"
max-incoming:0
TO_CLASS "Subprocess"
max-outgoing:0
FROM_CLASS "Activity"
max-incoming:0
TO_CLASS "Activity"
max-outgoing:0
FROM_CLASS "Decision"
max-incoming:0
TO_CLASS "Decision"

```

Part IV

```
max-outgoing:0
FROM_CLASS "Parallellity"
max-incoming:0
TO_CLASS "Parallellity"
max-outgoing:0
FROM_CLASS "Merging"
max-incoming:0
TO_CLASS "Merging"
max-outgoing:0
FROM_CLASS "End"
max-incoming:0
TO_CLASS "End"
max-outgoing:0
FROM_CLASS "Variable"
max-incoming:0
TO_CLASS "Variable"
max-outgoing:0
FROM_CLASS "Random generator"
max-incoming:0
TO_CLASS "Random generator"
max-outgoing:0
FROM_CLASS "Resource"
max-incoming:0
TO_CLASS "Resource"
max-outgoing:0
FROM_CLASS "Performance indicator overview"
max-incoming:0
TO_CLASS "Performance indicator overview"
max-outgoing:0
FROM_CLASS "Performance indicator"
max-incoming:0
TO_CLASS "Performance indicator"
max-outgoing:0
FROM_CLASS "Note"
max-incoming:0
TO_CLASS "Note"
max-outgoing:0
FROM_CLASS "Aggregation"
max-incoming:0
TO_CLASS "Aggregation"
max-outgoing:0
FROM_CLASS "Document"
max-incoming:0
TO_CLASS "Document"
max-outgoing:0
FROM_CLASS "Document"
max-incoming:0
TO_CLASS "Document"
max-outgoing:0
FROM_CLASS "actor"
max-incoming:0
TO_CLASS "actor"
max-outgoing:0
FROM_CLASS "use case"
max-incoming:0
TO_CLASS "use case"
max-outgoing:0
FROM_CLASS "system boundary"
max-incoming:0
TO_CLASS "system boundary"
max-outgoing:0
```

```

FROM_CLASS "system boundary"
max-incoming:0
TO_CLASS "system boundary"
max-outgoing:0
FROM_CLASS "Process"
max-incoming:0
TO_CLASS "Process"
max-outgoing:0
FROM_CLASS "Performance"
max-incoming:0
TO_CLASS "Performance"
max-outgoing:0
FROM_CLASS "External partner"
max-incoming:0
TO_CLASS "External partner"
max-outgoing:0
FROM_CLASS "Product"
max-incoming:0
TO_CLASS "Product"
max-outgoing:0
FROM_CLASS "Product component"
max-incoming:0
TO_CLASS "Product component"
max-outgoing:0
FROM_CLASS "Application"
max-incoming:0
TO_CLASS "Application"
max-outgoing:0
FROM_CLASS "Service"
max-incoming:0
TO_CLASS "Service"
max-outgoing:0
FROM_CLASS "Infrastructure element"
max-incoming:0
TO_CLASS "Infrastructure element"
max-outgoing:0

```

1.4.10 Class "Merging"

ADONIS BPMS BP Library 3.9:

```

CARDINALITIES
RELATION "Subsequent"
max-outgoing:1
min-incoming:2
RELATION "has Cross-reference"
FROM_CLASS "Cross-reference"
max-incoming:1000
TO_CLASS "Cross-reference"
max-outgoing:1000
FROM_CLASS "Trigger"
max-incoming:0
TO_CLASS "Trigger"
max-outgoing:0
FROM_CLASS "Process start"
max-incoming:0
TO_CLASS "Process start"
max-outgoing:0
FROM_CLASS "Subprocess"

```

Part IV

```
max-incoming:0
TO_CLASS "Subprocess"
max-outgoing:0
FROM_CLASS "Activity"
max-incoming:0
TO_CLASS "Activity"
max-outgoing:0
FROM_CLASS "Decision"
max-incoming:0
TO_CLASS "Decision"
max-outgoing:0
FROM_CLASS "Parallellity"
max-incoming:0
TO_CLASS "Parallellity"
max-outgoing:0
FROM_CLASS "Merging"
max-incoming:0
TO_CLASS "Merging"
max-outgoing:0
FROM_CLASS "End"
max-incoming:0
TO_CLASS "End"
max-outgoing:0
FROM_CLASS "Variable"
max-incoming:0
TO_CLASS "Variable"
max-outgoing:0
FROM_CLASS "Random generator"
max-incoming:0
TO_CLASS "Random generator"
max-outgoing:0
FROM_CLASS "Resource"
max-incoming:0
TO_CLASS "Resource"
max-outgoing:0
FROM_CLASS "Performance indicator overview"
max-incoming:0
TO_CLASS "Performance indicator overview"
max-outgoing:0
FROM_CLASS "Performance indicator"
max-incoming:0
TO_CLASS "Performance indicator"
max-outgoing:0
FROM_CLASS "Note"
max-incoming:0
TO_CLASS "Note"
max-outgoing:0
FROM_CLASS "Aggregation"
max-incoming:0
TO_CLASS "Aggregation"
max-outgoing:0
FROM_CLASS "Document"
max-incoming:0
TO_CLASS "Document"
max-outgoing:0
FROM_CLASS "Document"
max-incoming:0
TO_CLASS "Document"
max-outgoing:0
FROM_CLASS "actor"
max-incoming:0
```

```

TO_CLASS "actor"
max-outgoing:0
FROM_CLASS "use case"
max-incoming:0
TO_CLASS "use case"
max-outgoing:0
FROM_CLASS "system boundary"
max-incoming:0
TO_CLASS "system boundary"
max-outgoing:0
FROM_CLASS "system boundary"
max-incoming:0
TO_CLASS "system boundary"
max-outgoing:0
FROM_CLASS "Process"
max-incoming:0
TO_CLASS "Process"
max-outgoing:0
FROM_CLASS "Performance"
max-incoming:0
TO_CLASS "Performance"
max-outgoing:0
FROM_CLASS "External partner"
max-incoming:0
TO_CLASS "External partner"
max-outgoing:0
FROM_CLASS "Product"
max-incoming:0
TO_CLASS "Product"
max-outgoing:0
FROM_CLASS "Product component"
max-incoming:0
TO_CLASS "Product component"
max-outgoing:0
FROM_CLASS "Application"
max-incoming:0
TO_CLASS "Application"
max-outgoing:0
FROM_CLASS "Service"
max-incoming:0
TO_CLASS "Service"
max-outgoing:0
FROM_CLASS "Infrastructure element"
max-incoming:0
TO_CLASS "Infrastructure element"
max-outgoing:0

```

1.4.11 Class "End"

ADONIS BPMS BP Library 3.9:

```

CARDINALITIES
min-objects:1
RELATION "Subsequent"
max-outgoing:0
min-incoming:1
RELATION "has Cross-reference"
FROM_CLASS "Cross-reference"
max-incoming:1000

```

Part IV

```
TO_CLASS "Cross-reference"
max-outgoing:1000
FROM_CLASS "Trigger"
max-incoming:0
TO_CLASS "Trigger"
max-outgoing:0
FROM_CLASS "Process start"
max-incoming:0
TO_CLASS "Process start"
max-outgoing:0
FROM_CLASS "Subprocess"
max-incoming:0
TO_CLASS "Subprocess"
max-outgoing:0
FROM_CLASS "Activity"
max-incoming:0
TO_CLASS "Activity"
max-outgoing:0
FROM_CLASS "Decision"
max-incoming:0
TO_CLASS "Decision"
max-outgoing:0
FROM_CLASS "Parallelity"
max-incoming:0
TO_CLASS "Parallelity"
max-outgoing:0
FROM_CLASS "Merging"
max-incoming:0
TO_CLASS "Merging"
max-outgoing:0
FROM_CLASS "End"
max-incoming:0
TO_CLASS "End"
max-outgoing:0
FROM_CLASS "Variable"
max-incoming:0
TO_CLASS "Variable"
max-outgoing:0
FROM_CLASS "Random generator"
max-incoming:0
TO_CLASS "Random generator"
max-outgoing:0
FROM_CLASS "Resource"
max-incoming:0
TO_CLASS "Resource"
max-outgoing:0
FROM_CLASS "Performance indicator overview"
max-incoming:0
TO_CLASS "Performance indicator overview"
max-outgoing:0
FROM_CLASS "Performance indicator"
max-incoming:0
TO_CLASS "Performance indicator"
max-outgoing:0
FROM_CLASS "Note"
max-incoming:0
TO_CLASS "Note"
max-outgoing:0
FROM_CLASS "Aggregation"
max-incoming:0
TO_CLASS "Aggregation"
```

```
max-outgoing:0
FROM_CLASS "Document"
max-incoming:0
TO_CLASS "Document"
max-outgoing:0
FROM_CLASS "Document"
max-incoming:0
TO_CLASS "Document"
max-outgoing:0
FROM_CLASS "actor"
max-incoming:0
TO_CLASS "actor"
max-outgoing:0
FROM_CLASS "use case"
max-incoming:0
TO_CLASS "use case"
max-outgoing:0
FROM_CLASS "system boundary"
max-incoming:0
TO_CLASS "system boundary"
max-outgoing:0
FROM_CLASS "system boundary"
max-incoming:0
TO_CLASS "system boundary"
max-outgoing:0
FROM_CLASS "Process"
max-incoming:0
TO_CLASS "Process"
max-outgoing:0
FROM_CLASS "Performance"
max-incoming:0
TO_CLASS "Performance"
max-outgoing:0
FROM_CLASS "External partner"
max-incoming:0
TO_CLASS "External partner"
max-outgoing:0
FROM_CLASS "Product"
max-incoming:0
TO_CLASS "Product"
max-outgoing:0
FROM_CLASS "Product component"
max-incoming:0
TO_CLASS "Product component"
max-outgoing:0
FROM_CLASS "Application"
max-incoming:0
TO_CLASS "Application"
max-outgoing:0
FROM_CLASS "Service"
max-incoming:0
TO_CLASS "Service"
max-outgoing:0
FROM_CLASS "Infrastructure element"
max-incoming:0
TO_CLASS "Infrastructure element"
max-outgoing:0
```

1.4.12 Class "Variable"

ADONIS BPMS BP Library 3.9:

```
CARDINALITIES
RELATION "Sets variable"
min-incoming:1
RELATION "has Cross-reference"
FROM_CLASS "Cross-reference"
max-incoming:1000
TO_CLASS "Cross-reference"
max-outgoing:1000
FROM_CLASS "Trigger"
max-incoming:0
TO_CLASS "Trigger"
max-outgoing:0
FROM_CLASS "Process start"
max-incoming:0
TO_CLASS "Process start"
max-outgoing:0
FROM_CLASS "Subprocess"
max-incoming:0
TO_CLASS "Subprocess"
max-outgoing:0
FROM_CLASS "Activity"
max-incoming:0
TO_CLASS "Activity"
max-outgoing:0
FROM_CLASS "Decision"
max-incoming:0
TO_CLASS "Decision"
max-outgoing:0
FROM_CLASS "Parallelity"
max-incoming:0
TO_CLASS "Parallelity"
max-outgoing:0
FROM_CLASS "Merging"
max-incoming:0
TO_CLASS "Merging"
max-outgoing:0
FROM_CLASS "End"
max-incoming:0
TO_CLASS "End"
max-outgoing:0
FROM_CLASS "Variable"
max-incoming:0
TO_CLASS "Variable"
max-outgoing:0
FROM_CLASS "Random generator"
max-incoming:0
TO_CLASS "Random generator"
max-outgoing:0
FROM_CLASS "Resource"
max-incoming:0
TO_CLASS "Resource"
max-outgoing:0
FROM_CLASS "Performance indicator overview"
max-incoming:0
TO_CLASS "Performance indicator overview"
max-outgoing:0
FROM_CLASS "Performance indicator"
```



```
max-incoming:0
TO_CLASS "Performance indicator"
max-outgoing:0
FROM_CLASS "Note"
max-incoming:0
TO_CLASS "Note"
max-outgoing:0
FROM_CLASS "Aggregation"
max-incoming:0
TO_CLASS "Aggregation"
max-outgoing:0
FROM_CLASS "Document"
max-incoming:0
TO_CLASS "Document"
max-outgoing:0
FROM_CLASS "Document"
max-incoming:0
TO_CLASS "Document"
max-outgoing:0
FROM_CLASS "actor"
max-incoming:0
TO_CLASS "actor"
max-outgoing:0
FROM_CLASS "use case"
max-incoming:0
TO_CLASS "use case"
max-outgoing:0
FROM_CLASS "system boundary"
max-incoming:0
TO_CLASS "system boundary"
max-outgoing:0
FROM_CLASS "system boundary"
max-incoming:0
TO_CLASS "system boundary"
max-outgoing:0
FROM_CLASS "Process"
max-incoming:0
TO_CLASS "Process"
max-outgoing:0
FROM_CLASS "Performance"
max-incoming:0
TO_CLASS "Performance"
max-outgoing:0
FROM_CLASS "External partner"
max-incoming:0
TO_CLASS "External partner"
max-outgoing:0
FROM_CLASS "Product"
max-incoming:0
TO_CLASS "Product"
max-outgoing:0
FROM_CLASS "Product component"
max-incoming:0
TO_CLASS "Product component"
max-outgoing:0
FROM_CLASS "Application"
max-incoming:0
TO_CLASS "Application"
max-outgoing:0
FROM_CLASS "Service"
max-incoming:0
```

Part IV

```
TO_CLASS "Service"
max-outgoing:0
FROM_CLASS "Infrastructure element"
max-incoming:0
TO_CLASS "Infrastructure element"
max-outgoing:0
```

1.4.13 Class "Random generator"

ADONIS BPMS BP Library 3.9:

```
CARDINALITIES
RELATION "Sets variable"
min-outgoing:1
RELATION "Sets"
min-outgoing:1
RELATION "has Cross-reference"
FROM_CLASS "Cross-reference"
max-incoming:1000
TO_CLASS "Cross-reference"
max-outgoing:1000
FROM_CLASS "Trigger"
max-incoming:0
TO_CLASS "Trigger"
max-outgoing:0
FROM_CLASS "Process start"
max-incoming:0
TO_CLASS "Process start"
max-outgoing:0
FROM_CLASS "Subprocess"
max-incoming:0
TO_CLASS "Subprocess"
max-outgoing:0
FROM_CLASS "Activity"
max-incoming:0
TO_CLASS "Activity"
max-outgoing:0
FROM_CLASS "Decision"
max-incoming:0
TO_CLASS "Decision"
max-outgoing:0
FROM_CLASS "Parallelity"
max-incoming:0
TO_CLASS "Parallelity"
max-outgoing:0
FROM_CLASS "Merging"
max-incoming:0
TO_CLASS "Merging"
max-outgoing:0
FROM_CLASS "End"
max-incoming:0
TO_CLASS "End"
max-outgoing:0
FROM_CLASS "Variable"
max-incoming:0
TO_CLASS "Variable"
max-outgoing:0
FROM_CLASS "Random generator"
max-incoming:0
```

```

TO_CLASS "Random generator"
max-outgoing:0
FROM_CLASS "Resource"
max-incoming:0
TO_CLASS "Resource"
max-outgoing:0
FROM_CLASS "Performance indicator overview"
max-incoming:0
TO_CLASS "Performance indicator overview"
max-outgoing:0
FROM_CLASS "Performance indicator"
max-incoming:0
TO_CLASS "Performance indicator"
max-outgoing:0
FROM_CLASS "Note"
max-incoming:0
TO_CLASS "Note"
max-outgoing:0
FROM_CLASS "Aggregation"
max-incoming:0
TO_CLASS "Aggregation"
max-outgoing:0
FROM_CLASS "Document"
max-incoming:0
TO_CLASS "Document"
max-outgoing:0
FROM_CLASS "Document"
max-incoming:0
TO_CLASS "Document"
max-outgoing:0
FROM_CLASS "actor"
max-incoming:0
TO_CLASS "actor"
max-outgoing:0
FROM_CLASS "use case"
max-incoming:0
TO_CLASS "use case"
max-outgoing:0
FROM_CLASS "system boundary"
max-incoming:0
TO_CLASS "system boundary"
max-outgoing:0
FROM_CLASS "system boundary"
max-incoming:0
TO_CLASS "system boundary"
max-outgoing:0
FROM_CLASS "Process"
max-incoming:0
TO_CLASS "Process"
max-outgoing:0
FROM_CLASS "Performance"
max-incoming:0
TO_CLASS "Performance"
max-outgoing:0
FROM_CLASS "External partner"
max-incoming:0
TO_CLASS "External partner"
max-outgoing:0
FROM_CLASS "Product"
max-incoming:0
TO_CLASS "Product"

```

Part IV

```
max-outgoing:0
FROM_CLASS "Product component"
max-incoming:0
TO_CLASS "Product component"
max-outgoing:0
FROM_CLASS "Application"
max-incoming:0
TO_CLASS "Application"
max-outgoing:0
FROM_CLASS "Service"
max-incoming:0
TO_CLASS "Service"
max-outgoing:0
FROM_CLASS "Infrastructure element"
max-incoming:0
TO_CLASS "Infrastructure element"
max-outgoing:0
```

1.4.14 Class "Resource"

ADONIS BPMS BP Library 3.9:

```
CARDINALITIES
RELATION "has Cross-reference"
FROM_CLASS "Cross-reference"
max-incoming:1000
TO_CLASS "Cross-reference"
max-outgoing:1000
FROM_CLASS "Trigger"
max-incoming:0
TO_CLASS "Trigger"
max-outgoing:0
FROM_CLASS "Process start"
max-incoming:0
TO_CLASS "Process start"
max-outgoing:0
FROM_CLASS "Subprocess"
max-incoming:0
TO_CLASS "Subprocess"
max-outgoing:0
FROM_CLASS "Activity"
max-incoming:0
TO_CLASS "Activity"
max-outgoing:0
FROM_CLASS "Decision"
max-incoming:0
TO_CLASS "Decision"
max-outgoing:0
FROM_CLASS "Parallelity"
max-incoming:0
TO_CLASS "Parallelity"
max-outgoing:0
FROM_CLASS "Merging"
max-incoming:0
TO_CLASS "Merging"
max-outgoing:0
FROM_CLASS "End"
max-incoming:0
TO_CLASS "End"
```

```

max-outgoing:0
FROM_CLASS "Variable"
max-incoming:0
TO_CLASS "Variable"
max-outgoing:0
FROM_CLASS "Random generator"
max-incoming:0
TO_CLASS "Random generator"
max-outgoing:0
FROM_CLASS "Resource"
max-incoming:0
TO_CLASS "Resource"
max-outgoing:0
FROM_CLASS "Performance indicator overview"
max-incoming:0
TO_CLASS "Performance indicator overview"
max-outgoing:0
FROM_CLASS "Performance indicator"
max-incoming:0
TO_CLASS "Performance indicator"
max-outgoing:0
FROM_CLASS "Note"
max-incoming:0
TO_CLASS "Note"
max-outgoing:0
FROM_CLASS "Aggregation"
max-incoming:0
TO_CLASS "Aggregation"
max-outgoing:0
FROM_CLASS "Document"
max-incoming:0
TO_CLASS "Document"
max-outgoing:0
FROM_CLASS "Document"
max-incoming:0
TO_CLASS "Document"
max-outgoing:0
FROM_CLASS "actor"
max-incoming:0
TO_CLASS "actor"
max-outgoing:0
FROM_CLASS "use case"
max-incoming:0
TO_CLASS "use case"
max-outgoing:0
FROM_CLASS "system boundary"
max-incoming:0
TO_CLASS "system boundary"
max-outgoing:0
FROM_CLASS "system boundary"
max-incoming:0
TO_CLASS "system boundary"
max-outgoing:0
FROM_CLASS "Process"
max-incoming:0
TO_CLASS "Process"
max-outgoing:0
FROM_CLASS "Performance"
max-incoming:0
TO_CLASS "Performance"
max-outgoing:0

```

Part IV

```
FROM_CLASS "External partner"
max-incoming:0
TO_CLASS "External partner"
max-outgoing:0
FROM_CLASS "Product"
max-incoming:0
TO_CLASS "Product"
max-outgoing:0
FROM_CLASS "Product component"
max-incoming:0
TO_CLASS "Product component"
max-outgoing:0
FROM_CLASS "Application"
max-incoming:0
TO_CLASS "Application"
max-outgoing:0
FROM_CLASS "Service"
max-incoming:0
TO_CLASS "Service"
max-outgoing:0
FROM_CLASS "Infrastructure element"
max-incoming:0
TO_CLASS "Infrastructure element"
max-outgoing:0
```

1.4.15 Class "Process"

ADONIS BPMS BP Library 3.9:

```
CARDINALITIES
RELATION "has Cross-reference"
FROM_CLASS "Cross-reference"
max-incoming:1000
TO_CLASS "Cross-reference"
max-outgoing:1000
FROM_CLASS "Trigger"
max-incoming:0
TO_CLASS "Trigger"
max-outgoing:0
FROM_CLASS "Process start"
max-incoming:0
TO_CLASS "Process start"
max-outgoing:0
FROM_CLASS "Subprocess"
max-incoming:0
TO_CLASS "Subprocess"
max-outgoing:0
FROM_CLASS "Activity"
max-incoming:0
TO_CLASS "Activity"
max-outgoing:0
FROM_CLASS "Decision"
max-incoming:0
TO_CLASS "Decision"
max-outgoing:0
FROM_CLASS "Parallelity"
max-incoming:0
TO_CLASS "Parallelity"
max-outgoing:0
```

```

FROM_CLASS "Merging"
max-incoming:0
TO_CLASS "Merging"
max-outgoing:0
FROM_CLASS "End"
max-incoming:0
TO_CLASS "End"
max-outgoing:0
FROM_CLASS "Variable"
max-incoming:0
TO_CLASS "Variable"
max-outgoing:0
FROM_CLASS "Random generator"
max-incoming:0
TO_CLASS "Random generator"
max-outgoing:0
FROM_CLASS "Resource"
max-incoming:0
TO_CLASS "Resource"
max-outgoing:0
FROM_CLASS "Performance indicator overview"
max-incoming:0
TO_CLASS "Performance indicator overview"
max-outgoing:0
FROM_CLASS "Performance indicator"
max-incoming:0
TO_CLASS "Performance indicator"
max-outgoing:0
FROM_CLASS "Note"
max-incoming:0
TO_CLASS "Note"
max-outgoing:0
FROM_CLASS "Aggregation"
max-incoming:0
TO_CLASS "Aggregation"
max-outgoing:0
FROM_CLASS "Document"
max-incoming:0
TO_CLASS "Document"
max-outgoing:0
FROM_CLASS "Document"
max-incoming:0
TO_CLASS "Document"
max-outgoing:0
FROM_CLASS "actor"
max-incoming:0
TO_CLASS "actor"
max-outgoing:0
FROM_CLASS "use case"
max-incoming:0
TO_CLASS "use case"
max-outgoing:0
FROM_CLASS "system boundary"
max-incoming:0
TO_CLASS "system boundary"
max-outgoing:0
FROM_CLASS "system boundary"
max-incoming:0
TO_CLASS "system boundary"
max-outgoing:0
FROM_CLASS "Process"

```

Part IV

```
max-incoming:0
TO_CLASS "Process"
max-outgoing:0
FROM_CLASS "Performance"
max-incoming:0
TO_CLASS "Performance"
max-outgoing:0
FROM_CLASS "External partner"
max-incoming:0
TO_CLASS "External partner"
max-outgoing:0
FROM_CLASS "Product"
max-incoming:0
TO_CLASS "Product"
max-outgoing:0
FROM_CLASS "Product component"
max-incoming:0
TO_CLASS "Product component"
max-outgoing:0
FROM_CLASS "Application"
max-incoming:0
TO_CLASS "Application"
max-outgoing:0
FROM_CLASS "Service"
max-incoming:0
TO_CLASS "Service"
max-outgoing:0
FROM_CLASS "Infrastructure element"
max-incoming:0
TO_CLASS "Infrastructure element"
max-outgoing:0
```

1.4.16 Class "Performance indicator overview"

ADONIS BPMS BP Library 3.9:

```
CARDINALITIES
max-objects: 1
max-incoming: 0
RELATION "Owns"
max-outgoing:0
RELATION "has Cross-reference"
FROM_CLASS "Cross-reference"
max-incoming:1000
TO_CLASS "Cross-reference"
max-outgoing:1000
FROM_CLASS "Trigger"
max-incoming:0
TO_CLASS "Trigger"
max-outgoing:0
FROM_CLASS "Process start"
max-incoming:0
TO_CLASS "Process start"
max-outgoing:0
FROM_CLASS "Subprocess"
max-incoming:0
TO_CLASS "Subprocess"
max-outgoing:0
FROM_CLASS "Activity"
```



```

max-incoming:0
TO_CLASS "Activity"
max-outgoing:0
FROM_CLASS "Decision"
max-incoming:0
TO_CLASS "Decision"
max-outgoing:0
FROM_CLASS "Parallelity"
max-incoming:0
TO_CLASS "Parallelity"
max-outgoing:0
FROM_CLASS "Merging"
max-incoming:0
TO_CLASS "Merging"
max-outgoing:0
FROM_CLASS "End"
max-incoming:0
TO_CLASS "End"
max-outgoing:0
FROM_CLASS "Variable"
max-incoming:0
TO_CLASS "Variable"
max-outgoing:0
FROM_CLASS "Random generator"
max-incoming:0
TO_CLASS "Random generator"
max-outgoing:0
FROM_CLASS "Resource"
max-incoming:0
TO_CLASS "Resource"
max-outgoing:0
FROM_CLASS "Performance indicator overview"
max-incoming:0
TO_CLASS "Performance indicator overview"
max-outgoing:0
FROM_CLASS "Performance indicator"
max-incoming:0
TO_CLASS "Performance indicator"
max-outgoing:0
FROM_CLASS "Note"
max-incoming:0
TO_CLASS "Note"
max-outgoing:0
FROM_CLASS "Aggregation"
max-incoming:0
TO_CLASS "Aggregation"
max-outgoing:0
FROM_CLASS "Document"
max-incoming:0
TO_CLASS "Document"
max-outgoing:0
FROM_CLASS "Document"
max-incoming:0
TO_CLASS "Document"
max-outgoing:0
FROM_CLASS "actor"
max-incoming:0
TO_CLASS "actor"
max-outgoing:0
FROM_CLASS "use case"
max-incoming:0

```

Part IV

```
TO_CLASS "use case"
max-outgoing:0
FROM_CLASS "system boundary"
max-incoming:0
TO_CLASS "system boundary"
max-outgoing:0
FROM_CLASS "system boundary"
max-incoming:0
TO_CLASS "system boundary"
max-outgoing:0
FROM_CLASS "Process"
max-incoming:0
TO_CLASS "Process"
max-outgoing:0
FROM_CLASS "Performance"
max-incoming:0
TO_CLASS "Performance"
max-outgoing:0
FROM_CLASS "External partner"
max-incoming:0
TO_CLASS "External partner"
max-outgoing:0
FROM_CLASS "Product"
max-incoming:0
TO_CLASS "Product"
max-outgoing:0
FROM_CLASS "Product component"
max-incoming:0
TO_CLASS "Product component"
max-outgoing:0
FROM_CLASS "Application"
max-incoming:0
TO_CLASS "Application"
max-outgoing:0
FROM_CLASS "Service"
max-incoming:0
TO_CLASS "Service"
max-outgoing:0
FROM_CLASS "Infrastructure element"
max-incoming:0
TO_CLASS "Infrastructure element"
max-outgoing:0
```

1.4.17 Class "Performance indicator"

ADONIS BPMS BP Library 3.9:

```
CARDINALITIES
RELATION "has Cross-reference"
FROM_CLASS "Cross-reference"
max-incoming:1000
TO_CLASS "Cross-reference"
max-outgoing:1000
FROM_CLASS "Trigger"
max-incoming:0
TO_CLASS "Trigger"
max-outgoing:0
FROM_CLASS "Process start"
max-incoming:0
```

```

TO_CLASS "Process start"
max-outgoing:0
FROM_CLASS "Subprocess"
max-incoming:0
TO_CLASS "Subprocess"
max-outgoing:0
FROM_CLASS "Activity"
max-incoming:0
TO_CLASS "Activity"
max-outgoing:0
FROM_CLASS "Decision"
max-incoming:0
TO_CLASS "Decision"
max-outgoing:0
FROM_CLASS "Parallellity"
max-incoming:0
TO_CLASS "Parallellity"
max-outgoing:0
FROM_CLASS "Merging"
max-incoming:0
TO_CLASS "Merging"
max-outgoing:0
FROM_CLASS "End"
max-incoming:0
TO_CLASS "End"
max-outgoing:0
FROM_CLASS "Variable"
max-incoming:0
TO_CLASS "Variable"
max-outgoing:0
FROM_CLASS "Random generator"
max-incoming:0
TO_CLASS "Random generator"
max-outgoing:0
FROM_CLASS "Resource"
max-incoming:0
TO_CLASS "Resource"
max-outgoing:0
FROM_CLASS "Performance indicator overview"
max-incoming:0
TO_CLASS "Performance indicator overview"
max-outgoing:0
FROM_CLASS "Performance indicator"
max-incoming:0
TO_CLASS "Performance indicator"
max-outgoing:0
FROM_CLASS "Note"
max-incoming:0
TO_CLASS "Note"
max-outgoing:0
FROM_CLASS "Aggregation"
max-incoming:0
TO_CLASS "Aggregation"
max-outgoing:0
FROM_CLASS "Document"
max-incoming:0
TO_CLASS "Document"
max-outgoing:0
FROM_CLASS "Document"
max-incoming:0
TO_CLASS "Document"

```

Part IV

```
max-outgoing:0
FROM_CLASS "actor"
max-incoming:0
TO_CLASS "actor"
max-outgoing:0
FROM_CLASS "use case"
max-incoming:0
TO_CLASS "use case"
max-outgoing:0
FROM_CLASS "system boundary"
max-incoming:0
TO_CLASS "system boundary"
max-outgoing:0
FROM_CLASS "system boundary"
max-incoming:0
TO_CLASS "system boundary"
max-outgoing:0
FROM_CLASS "Process"
max-incoming:0
TO_CLASS "Process"
max-outgoing:0
FROM_CLASS "Performance"
max-incoming:0
TO_CLASS "Performance"
max-outgoing:0
FROM_CLASS "External partner"
max-incoming:0
TO_CLASS "External partner"
max-outgoing:0
FROM_CLASS "Product"
max-incoming:0
TO_CLASS "Product"
max-outgoing:0
FROM_CLASS "Product component"
max-incoming:0
TO_CLASS "Product component"
max-outgoing:0
FROM_CLASS "Application"
max-incoming:0
TO_CLASS "Application"
max-outgoing:0
FROM_CLASS "Service"
max-incoming:0
TO_CLASS "Service"
max-outgoing:0
FROM_CLASS "Infrastructure element"
max-incoming:0
TO_CLASS "Infrastructure element"
max-outgoing:0
```

1.4.18 Class "Document"

ADONIS BPMS BP Library 3.9:

```
CARDINALITIES
RELATION "has Cross-reference"
FROM_CLASS "Cross-reference"
max-incoming:1000
TO_CLASS "Cross-reference"
```

```
max-outgoing:1000
FROM_CLASS "Trigger"
max-incoming:0
TO_CLASS "Trigger"
max-outgoing:0
FROM_CLASS "Process start"
max-incoming:0
TO_CLASS "Process start"
max-outgoing:0
FROM_CLASS "Subprocess"
max-incoming:0
TO_CLASS "Subprocess"
max-outgoing:0
FROM_CLASS "Activity"
max-incoming:0
TO_CLASS "Activity"
max-outgoing:0
FROM_CLASS "Decision"
max-incoming:0
TO_CLASS "Decision"
max-outgoing:0
FROM_CLASS "Parallellity"
max-incoming:0
TO_CLASS "Parallellity"
max-outgoing:0
FROM_CLASS "Merging"
max-incoming:0
TO_CLASS "Merging"
max-outgoing:0
FROM_CLASS "End"
max-incoming:0
TO_CLASS "End"
max-outgoing:0
FROM_CLASS "Variable"
max-incoming:0
TO_CLASS "Variable"
max-outgoing:0
FROM_CLASS "Random generator"
max-incoming:0
TO_CLASS "Random generator"
max-outgoing:0
FROM_CLASS "Resource"
max-incoming:0
TO_CLASS "Resource"
max-outgoing:0
FROM_CLASS "Performance indicator overview"
max-incoming:0
TO_CLASS "Performance indicator overview"
max-outgoing:0
FROM_CLASS "Performance indicator"
max-incoming:0
TO_CLASS "Performance indicator"
max-outgoing:0
FROM_CLASS "Note"
max-incoming:0
TO_CLASS "Note"
max-outgoing:0
FROM_CLASS "Aggregation"
max-incoming:0
TO_CLASS "Aggregation"
max-outgoing:0
```

Part IV

```
FROM_CLASS "Document"
max-incoming:0
TO_CLASS "Document"
max-outgoing:0
FROM_CLASS "Document"
max-incoming:0
TO_CLASS "Document"
max-outgoing:0
FROM_CLASS "actor"
max-incoming:0
TO_CLASS "actor"
max-outgoing:0
FROM_CLASS "use case"
max-incoming:0
TO_CLASS "use case"
max-outgoing:0
FROM_CLASS "system boundary"
max-incoming:0
TO_CLASS "system boundary"
max-outgoing:0
FROM_CLASS "system boundary"
max-incoming:0
TO_CLASS "system boundary"
max-outgoing:0
FROM_CLASS "Process"
max-incoming:0
TO_CLASS "Process"
max-outgoing:0
FROM_CLASS "Performance"
max-incoming:0
TO_CLASS "Performance"
max-outgoing:0
FROM_CLASS "External partner"
max-incoming:0
TO_CLASS "External partner"
max-outgoing:0
FROM_CLASS "Product"
max-incoming:0
TO_CLASS "Product"
max-outgoing:0
FROM_CLASS "Product component"
max-incoming:0
TO_CLASS "Product component"
max-outgoing:0
FROM_CLASS "Application"
max-incoming:0
TO_CLASS "Application"
max-outgoing:0
FROM_CLASS "Service"
max-incoming:0
TO_CLASS "Service"
max-outgoing:0
FROM_CLASS "Infrastructure element"
max-incoming:0
TO_CLASS "Infrastructure element"
max-outgoing:0
```

1.4.19 Class "Note"

ADONIS BPMS BP Library 3.9:

```

CARDINALITIES
RELATION "has Cross-reference"
FROM_CLASS "Cross-reference"
max-incoming:1000
TO_CLASS "Cross-reference"
max-outgoing:1000
FROM_CLASS "Trigger"
max-incoming:0
TO_CLASS "Trigger"
max-outgoing:0
FROM_CLASS "Process start"
max-incoming:0
TO_CLASS "Process start"
max-outgoing:0
FROM_CLASS "Subprocess"
max-incoming:0
TO_CLASS "Subprocess"
max-outgoing:0
FROM_CLASS "Activity"
max-incoming:0
TO_CLASS "Activity"
max-outgoing:0
FROM_CLASS "Decision"
max-incoming:0
TO_CLASS "Decision"
max-outgoing:0
FROM_CLASS "Parallellity"
max-incoming:0
TO_CLASS "Parallellity"
max-outgoing:0
FROM_CLASS "Merging"
max-incoming:0
TO_CLASS "Merging"
max-outgoing:0
FROM_CLASS "End"
max-incoming:0
TO_CLASS "End"
max-outgoing:0
FROM_CLASS "Variable"
max-incoming:0
TO_CLASS "Variable"
max-outgoing:0
FROM_CLASS "Random generator"
max-incoming:0
TO_CLASS "Random generator"
max-outgoing:0
FROM_CLASS "Resource"
max-incoming:0
TO_CLASS "Resource"
max-outgoing:0
FROM_CLASS "Performance indicator overview"
max-incoming:0
TO_CLASS "Performance indicator overview"
max-outgoing:0
FROM_CLASS "Performance indicator"
max-incoming:0
TO_CLASS "Performance indicator"

```

Part IV

```
max-outgoing:0
FROM_CLASS "Note"
max-incoming:0
TO_CLASS "Note"
max-outgoing:0
FROM_CLASS "Aggregation"
max-incoming:0
TO_CLASS "Aggregation"
max-outgoing:0
FROM_CLASS "Document"
max-incoming:0
TO_CLASS "Document"
max-outgoing:0
FROM_CLASS "Document"
max-incoming:0
TO_CLASS "Document"
max-outgoing:0
FROM_CLASS "actor"
max-incoming:0
TO_CLASS "actor"
max-outgoing:0
FROM_CLASS "use case"
max-incoming:0
TO_CLASS "use case"
max-outgoing:0
FROM_CLASS "system boundary"
max-incoming:0
TO_CLASS "system boundary"
max-outgoing:0
FROM_CLASS "system boundary"
max-incoming:0
TO_CLASS "system boundary"
max-outgoing:0
FROM_CLASS "Process"
max-incoming:0
TO_CLASS "Process"
max-outgoing:0
FROM_CLASS "Performance"
max-incoming:0
TO_CLASS "Performance"
max-outgoing:0
FROM_CLASS "External partner"
max-incoming:0
TO_CLASS "External partner"
max-outgoing:0
FROM_CLASS "Product"
max-incoming:0
TO_CLASS "Product"
max-outgoing:0
FROM_CLASS "Product component"
max-incoming:0
TO_CLASS "Product component"
max-outgoing:0
FROM_CLASS "Application"
max-incoming:0
TO_CLASS "Application"
max-outgoing:0
FROM_CLASS "Service"
max-incoming:0
TO_CLASS "Service"
max-outgoing:0
```



```

FROM_CLASS "Infrastructure element"
max-incoming:0
TO_CLASS "Infrastructure element"
max-outgoing:0

```

1.4.20 Class "Aggregation"

ADONIS BPMS BP Library 3.9:

```

CARDINALITIES
RELATION "has Cross-reference"
FROM_CLASS "Cross-reference"
max-incoming:1000
TO_CLASS "Cross-reference"
max-outgoing:1000
FROM_CLASS "Trigger"
max-incoming:0
TO_CLASS "Trigger"
max-outgoing:0
FROM_CLASS "Process start"
max-incoming:0
TO_CLASS "Process start"
max-outgoing:0
FROM_CLASS "Subprocess"
max-incoming:0
TO_CLASS "Subprocess"
max-outgoing:0
FROM_CLASS "Activity"
max-incoming:0
TO_CLASS "Activity"
max-outgoing:0
FROM_CLASS "Decision"
max-incoming:0
TO_CLASS "Decision"
max-outgoing:0
FROM_CLASS "Parallellity"
max-incoming:0
TO_CLASS "Parallellity"
max-outgoing:0
FROM_CLASS "Merging"
max-incoming:0
TO_CLASS "Merging"
max-outgoing:0
FROM_CLASS "End"
max-incoming:0
TO_CLASS "End"
max-outgoing:0
FROM_CLASS "Variable"
max-incoming:0
TO_CLASS "Variable"
max-outgoing:0
FROM_CLASS "Random generator"
max-incoming:0
TO_CLASS "Random generator"
max-outgoing:0
FROM_CLASS "Resource"
max-incoming:0
TO_CLASS "Resource"
max-outgoing:0

```

Part IV

```
FROM_CLASS "Performance indicator overview"
max-incoming:0
TO_CLASS "Performance indicator overview"
max-outgoing:0
FROM_CLASS "Performance indicator"
max-incoming:0
TO_CLASS "Performance indicator"
max-outgoing:0
FROM_CLASS "Note"
max-incoming:0
TO_CLASS "Note"
max-outgoing:0
FROM_CLASS "Aggregation"
max-incoming:0
TO_CLASS "Aggregation"
max-outgoing:0
FROM_CLASS "Document"
max-incoming:0
TO_CLASS "Document"
max-outgoing:0
FROM_CLASS "Document"
max-incoming:0
TO_CLASS "Document"
max-outgoing:0
FROM_CLASS "actor"
max-incoming:0
TO_CLASS "actor"
max-outgoing:0
FROM_CLASS "use case"
max-incoming:0
TO_CLASS "use case"
max-outgoing:0
FROM_CLASS "system boundary"
max-incoming:0
TO_CLASS "system boundary"
max-outgoing:0
FROM_CLASS "system boundary"
max-incoming:0
TO_CLASS "system boundary"
max-outgoing:0
FROM_CLASS "Process"
max-incoming:0
TO_CLASS "Process"
max-outgoing:0
FROM_CLASS "Performance"
max-incoming:0
TO_CLASS "Performance"
max-outgoing:0
FROM_CLASS "External partner"
max-incoming:0
TO_CLASS "External partner"
max-outgoing:0
FROM_CLASS "Product"
max-incoming:0
TO_CLASS "Product"
max-outgoing:0
FROM_CLASS "Product component"
max-incoming:0
TO_CLASS "Product component"
max-outgoing:0
FROM_CLASS "Application"
```

```

max-incoming:0
TO_CLASS "Application"
max-outgoing:0
FROM_CLASS "Service"
max-incoming:0
TO_CLASS "Service"
max-outgoing:0
FROM_CLASS "Infrastructure element"
max-incoming:0
TO_CLASS "Infrastructure element"
max-outgoing:0

```

1.4.21 Class "External partner"

ADONIS BPMS BP Library 3.9:

```

CARDINALITIES
RELATION "has Cross-reference"
FROM_CLASS "Cross-reference"
max-incoming:1000
TO_CLASS "Cross-reference"
max-outgoing:1000
FROM_CLASS "Trigger"
max-incoming:0
TO_CLASS "Trigger"
max-outgoing:0
FROM_CLASS "Process start"
max-incoming:0
TO_CLASS "Process start"
max-outgoing:0
FROM_CLASS "Subprocess"
max-incoming:0
TO_CLASS "Subprocess"
max-outgoing:0
FROM_CLASS "Activity"
max-incoming:0
TO_CLASS "Activity"
max-outgoing:0
FROM_CLASS "Decision"
max-incoming:0
TO_CLASS "Decision"
max-outgoing:0
FROM_CLASS "Parallelity"
max-incoming:0
TO_CLASS "Parallelity"
max-outgoing:0
FROM_CLASS "Merging"
max-incoming:0
TO_CLASS "Merging"
max-outgoing:0
FROM_CLASS "End"
max-incoming:0
TO_CLASS "End"
max-outgoing:0
FROM_CLASS "Variable"
max-incoming:0
TO_CLASS "Variable"
max-outgoing:0
FROM_CLASS "Random generator"

```

Part IV

```
max-incoming:0
TO_CLASS "Random generator"
max-outgoing:0
FROM_CLASS "Resource"
max-incoming:0
TO_CLASS "Resource"
max-outgoing:0
FROM_CLASS "Performance indicator overview"
max-incoming:0
TO_CLASS "Performance indicator overview"
max-outgoing:0
FROM_CLASS "Performance indicator"
max-incoming:0
TO_CLASS "Performance indicator"
max-outgoing:0
FROM_CLASS "Note"
max-incoming:0
TO_CLASS "Note"
max-outgoing:0
FROM_CLASS "Aggregation"
max-incoming:0
TO_CLASS "Aggregation"
max-outgoing:0
FROM_CLASS "Document"
max-incoming:0
TO_CLASS "Document"
max-outgoing:0
FROM_CLASS "Document"
max-incoming:0
TO_CLASS "Document"
max-outgoing:0
FROM_CLASS "actor"
max-incoming:0
TO_CLASS "actor"
max-outgoing:0
FROM_CLASS "use case"
max-incoming:0
TO_CLASS "use case"
max-outgoing:0
FROM_CLASS "system boundary"
max-incoming:0
TO_CLASS "system boundary"
max-outgoing:0
FROM_CLASS "system boundary"
max-incoming:0
TO_CLASS "system boundary"
max-outgoing:0
FROM_CLASS "Process"
max-incoming:0
TO_CLASS "Process"
max-outgoing:0
FROM_CLASS "Performance"
max-incoming:0
TO_CLASS "Performance"
max-outgoing:0
FROM_CLASS "External partner"
max-incoming:0
TO_CLASS "External partner"
max-outgoing:0
FROM_CLASS "Product"
max-incoming:0
```

```

TO_CLASS "Product"
max-outgoing:0
FROM_CLASS "Product component"
max-incoming:0
TO_CLASS "Product component"
max-outgoing:0
FROM_CLASS "Application"
max-incoming:0
TO_CLASS "Application"
max-outgoing:0
FROM_CLASS "Service"
max-incoming:0
TO_CLASS "Service"
max-outgoing:0
FROM_CLASS "Infrastructure element"
max-incoming:0
TO_CLASS "Infrastructure element"
max-outgoing:0

```

1.4.22 Class "Product"

ADONIS BPMS BP Library 3.9:

```

CARDINALITIES
RELATION "has Cross-reference"
FROM_CLASS "Cross-reference"
max-incoming:1000
TO_CLASS "Cross-reference"
max-outgoing:1000
FROM_CLASS "Trigger"
max-incoming:0
TO_CLASS "Trigger"
max-outgoing:0
FROM_CLASS "Process start"
max-incoming:0
TO_CLASS "Process start"
max-outgoing:0
FROM_CLASS "Subprocess"
max-incoming:0
TO_CLASS "Subprocess"
max-outgoing:0
FROM_CLASS "Activity"
max-incoming:0
TO_CLASS "Activity"
max-outgoing:0
FROM_CLASS "Decision"
max-incoming:0
TO_CLASS "Decision"
max-outgoing:0
FROM_CLASS "Parallelity"
max-incoming:0
TO_CLASS "Parallelity"
max-outgoing:0
FROM_CLASS "Merging"
max-incoming:0
TO_CLASS "Merging"
max-outgoing:0
FROM_CLASS "End"
max-incoming:0

```

Part IV

```
TO_CLASS "End"
max-outgoing:0
FROM_CLASS "Variable"
max-incoming:0
TO_CLASS "Variable"
max-outgoing:0
FROM_CLASS "Random generator"
max-incoming:0
TO_CLASS "Random generator"
max-outgoing:0
FROM_CLASS "Resource"
max-incoming:0
TO_CLASS "Resource"
max-outgoing:0
FROM_CLASS "Performance indicator overview"
max-incoming:0
TO_CLASS "Performance indicator overview"
max-outgoing:0
FROM_CLASS "Performance indicator"
max-incoming:0
TO_CLASS "Performance indicator"
max-outgoing:0
FROM_CLASS "Note"
max-incoming:0
TO_CLASS "Note"
max-outgoing:0
FROM_CLASS "Aggregation"
max-incoming:0
TO_CLASS "Aggregation"
max-outgoing:0
FROM_CLASS "Document"
max-incoming:0
TO_CLASS "Document"
max-outgoing:0
FROM_CLASS "Document"
max-incoming:0
TO_CLASS "Document"
max-outgoing:0
FROM_CLASS "actor"
max-incoming:0
TO_CLASS "actor"
max-outgoing:0
FROM_CLASS "use case"
max-incoming:0
TO_CLASS "use case"
max-outgoing:0
FROM_CLASS "system boundary"
max-incoming:0
TO_CLASS "system boundary"
max-outgoing:0
FROM_CLASS "system boundary"
max-incoming:0
TO_CLASS "system boundary"
max-outgoing:0
FROM_CLASS "Process"
max-incoming:0
TO_CLASS "Process"
max-outgoing:0
FROM_CLASS "Performance"
max-incoming:0
TO_CLASS "Performance"
```

```

max-outgoing:0
FROM_CLASS "External partner"
max-incoming:0
TO_CLASS "External partner"
max-outgoing:0
FROM_CLASS "Product"
max-incoming:0
TO_CLASS "Product"
max-outgoing:0
FROM_CLASS "Product component"
max-incoming:0
TO_CLASS "Product component"
max-outgoing:0
FROM_CLASS "Application"
max-incoming:0
TO_CLASS "Application"
max-outgoing:0
FROM_CLASS "Service"
max-incoming:0
TO_CLASS "Service"
max-outgoing:0
FROM_CLASS "Infrastructure element"
max-incoming:0
TO_CLASS "Infrastructure element"
max-outgoing:0

```

1.4.23 Class "Product component"

ADONIS BPMS BP Library 3.9:

```

CARDINALITIES
RELATION "has Cross-reference"
FROM_CLASS "Cross-reference"
max-incoming:1000
TO_CLASS "Cross-reference"
max-outgoing:1000
FROM_CLASS "Trigger"
max-incoming:0
TO_CLASS "Trigger"
max-outgoing:0
FROM_CLASS "Process start"
max-incoming:0
TO_CLASS "Process start"
max-outgoing:0
FROM_CLASS "Subprocess"
max-incoming:0
TO_CLASS "Subprocess"
max-outgoing:0
FROM_CLASS "Activity"
max-incoming:0
TO_CLASS "Activity"
max-outgoing:0
FROM_CLASS "Decision"
max-incoming:0
TO_CLASS "Decision"
max-outgoing:0
FROM_CLASS "Parallellity"
max-incoming:0
TO_CLASS "Parallellity"

```

Part IV

```
max-outgoing:0
FROM_CLASS "Merging"
max-incoming:0
TO_CLASS "Merging"
max-outgoing:0
FROM_CLASS "End"
max-incoming:0
TO_CLASS "End"
max-outgoing:0
FROM_CLASS "Variable"
max-incoming:0
TO_CLASS "Variable"
max-outgoing:0
FROM_CLASS "Random generator"
max-incoming:0
TO_CLASS "Random generator"
max-outgoing:0
FROM_CLASS "Resource"
max-incoming:0
TO_CLASS "Resource"
max-outgoing:0
FROM_CLASS "Performance indicator overview"
max-incoming:0
TO_CLASS "Performance indicator overview"
max-outgoing:0
FROM_CLASS "Performance indicator"
max-incoming:0
TO_CLASS "Performance indicator"
max-outgoing:0
FROM_CLASS "Note"
max-incoming:0
TO_CLASS "Note"
max-outgoing:0
FROM_CLASS "Aggregation"
max-incoming:0
TO_CLASS "Aggregation"
max-outgoing:0
FROM_CLASS "Document"
max-incoming:0
TO_CLASS "Document"
max-outgoing:0
FROM_CLASS "Document"
max-incoming:0
TO_CLASS "Document"
max-outgoing:0
FROM_CLASS "actor"
max-incoming:0
TO_CLASS "actor"
max-outgoing:0
FROM_CLASS "use case"
max-incoming:0
TO_CLASS "use case"
max-outgoing:0
FROM_CLASS "system boundary"
max-incoming:0
TO_CLASS "system boundary"
max-outgoing:0
FROM_CLASS "system boundary"
max-incoming:0
TO_CLASS "system boundary"
max-outgoing:0
```



```

FROM_CLASS "Process"
max-incoming:0
TO_CLASS "Process"
max-outgoing:0
FROM_CLASS "Performance"
max-incoming:0
TO_CLASS "Performance"
max-outgoing:0
FROM_CLASS "External partner"
max-incoming:0
TO_CLASS "External partner"
max-outgoing:0
FROM_CLASS "Product"
max-incoming:0
TO_CLASS "Product"
max-outgoing:0
FROM_CLASS "Product component"
max-incoming:0
TO_CLASS "Product component"
max-outgoing:0
FROM_CLASS "Application"
max-incoming:0
TO_CLASS "Application"
max-outgoing:0
FROM_CLASS "Service"
max-incoming:0
TO_CLASS "Service"
max-outgoing:0
FROM_CLASS "Infrastructure element"
max-incoming:0
TO_CLASS "Infrastructure element"
max-outgoing:0

```

1.4.24 Class "Application"

ADONIS BPMS BP Library 3.9:

```

CARDINALITIES
RELATION "has Cross-reference"
FROM_CLASS "Cross-reference"
max-incoming:1000
TO_CLASS "Cross-reference"
max-outgoing:1000
FROM_CLASS "Trigger"
max-incoming:0
TO_CLASS "Trigger"
max-outgoing:0
FROM_CLASS "Process start"
max-incoming:0
TO_CLASS "Process start"
max-outgoing:0
FROM_CLASS "Subprocess"
max-incoming:0
TO_CLASS "Subprocess"
max-outgoing:0
FROM_CLASS "Activity"
max-incoming:0
TO_CLASS "Activity"
max-outgoing:0

```

Part IV

```
FROM_CLASS "Decision"
max-incoming:0
TO_CLASS "Decision"
max-outgoing:0
FROM_CLASS "Parallellity"
max-incoming:0
TO_CLASS "Parallellity"
max-outgoing:0
FROM_CLASS "Merging"
max-incoming:0
TO_CLASS "Merging"
max-outgoing:0
FROM_CLASS "End"
max-incoming:0
TO_CLASS "End"
max-outgoing:0
FROM_CLASS "Variable"
max-incoming:0
TO_CLASS "Variable"
max-outgoing:0
FROM_CLASS "Random generator"
max-incoming:0
TO_CLASS "Random generator"
max-outgoing:0
FROM_CLASS "Resource"
max-incoming:0
TO_CLASS "Resource"
max-outgoing:0
FROM_CLASS "Performance indicator overview"
max-incoming:0
TO_CLASS "Performance indicator overview"
max-outgoing:0
FROM_CLASS "Performance indicator"
max-incoming:0
TO_CLASS "Performance indicator"
max-outgoing:0
FROM_CLASS "Note"
max-incoming:0
TO_CLASS "Note"
max-outgoing:0
FROM_CLASS "Aggregation"
max-incoming:0
TO_CLASS "Aggregation"
max-outgoing:0
FROM_CLASS "Document"
max-incoming:0
TO_CLASS "Document"
max-outgoing:0
FROM_CLASS "Document"
max-incoming:0
TO_CLASS "Document"
max-outgoing:0
FROM_CLASS "actor"
max-incoming:0
TO_CLASS "actor"
max-outgoing:0
FROM_CLASS "use case"
max-incoming:0
TO_CLASS "use case"
max-outgoing:0
FROM_CLASS "system boundary"
```

```

max-incoming:0
TO_CLASS "system boundary"
max-outgoing:0
FROM_CLASS "system boundary"
max-incoming:0
TO_CLASS "system boundary"
max-outgoing:0
FROM_CLASS "Process"
max-incoming:0
TO_CLASS "Process"
max-outgoing:0
FROM_CLASS "Performance"
max-incoming:0
TO_CLASS "Performance"
max-outgoing:0
FROM_CLASS "External partner"
max-incoming:0
TO_CLASS "External partner"
max-outgoing:0
FROM_CLASS "Product"
max-incoming:0
TO_CLASS "Product"
max-outgoing:0
FROM_CLASS "Product component"
max-incoming:0
TO_CLASS "Product component"
max-outgoing:0
FROM_CLASS "Application"
max-incoming:0
TO_CLASS "Application"
max-outgoing:0
FROM_CLASS "Service"
max-incoming:0
TO_CLASS "Service"
max-outgoing:0
FROM_CLASS "Infrastructure element"
max-incoming:0
TO_CLASS "Infrastructure element"
max-outgoing:0

```

1.4.25 Class "Service"

ADONIS BPMS BP Library 3.9:

```

CARDINALITIES
RELATION "has Cross-reference"
FROM_CLASS "Cross-reference"
max-incoming:1000
TO_CLASS "Cross-reference"
max-outgoing:1000
FROM_CLASS "Trigger"
max-incoming:0
TO_CLASS "Trigger"
max-outgoing:0
FROM_CLASS "Process start"
max-incoming:0
TO_CLASS "Process start"
max-outgoing:0
FROM_CLASS "Subprocess"

```

Part IV

```
max-incoming:0
TO_CLASS "Subprocess"
max-outgoing:0
FROM_CLASS "Activity"
max-incoming:0
TO_CLASS "Activity"
max-outgoing:0
FROM_CLASS "Decision"
max-incoming:0
TO_CLASS "Decision"
max-outgoing:0
FROM_CLASS "Parallelity"
max-incoming:0
TO_CLASS "Parallelity"
max-outgoing:0
FROM_CLASS "Merging"
max-incoming:0
TO_CLASS "Merging"
max-outgoing:0
FROM_CLASS "End"
max-incoming:0
TO_CLASS "End"
max-outgoing:0
FROM_CLASS "Variable"
max-incoming:0
TO_CLASS "Variable"
max-outgoing:0
FROM_CLASS "Random generator"
max-incoming:0
TO_CLASS "Random generator"
max-outgoing:0
FROM_CLASS "Resource"
max-incoming:0
TO_CLASS "Resource"
max-outgoing:0
FROM_CLASS "Performance indicator overview"
max-incoming:0
TO_CLASS "Performance indicator overview"
max-outgoing:0
FROM_CLASS "Performance indicator"
max-incoming:0
TO_CLASS "Performance indicator"
max-outgoing:0
FROM_CLASS "Note"
max-incoming:0
TO_CLASS "Note"
max-outgoing:0
FROM_CLASS "Aggregation"
max-incoming:0
TO_CLASS "Aggregation"
max-outgoing:0
FROM_CLASS "Document"
max-incoming:0
TO_CLASS "Document"
max-outgoing:0
FROM_CLASS "Document"
max-incoming:0
TO_CLASS "Document"
max-outgoing:0
FROM_CLASS "actor"
max-incoming:0
```

```

TO_CLASS "actor"
max-outgoing:0
FROM_CLASS "use case"
max-incoming:0
TO_CLASS "use case"
max-outgoing:0
FROM_CLASS "system boundary"
max-incoming:0
TO_CLASS "system boundary"
max-outgoing:0
FROM_CLASS "system boundary"
max-incoming:0
TO_CLASS "system boundary"
max-outgoing:0
FROM_CLASS "Process"
max-incoming:0
TO_CLASS "Process"
max-outgoing:0
FROM_CLASS "Performance"
max-incoming:0
TO_CLASS "Performance"
max-outgoing:0
FROM_CLASS "External partner"
max-incoming:0
TO_CLASS "External partner"
max-outgoing:0
FROM_CLASS "Product"
max-incoming:0
TO_CLASS "Product"
max-outgoing:0
FROM_CLASS "Product component"
max-incoming:0
TO_CLASS "Product component"
max-outgoing:0
FROM_CLASS "Application"
max-incoming:0
TO_CLASS "Application"
max-outgoing:0
FROM_CLASS "Service"
max-incoming:0
TO_CLASS "Service"
max-outgoing:0
FROM_CLASS "Infrastructure element"
max-incoming:0
TO_CLASS "Infrastructure element"
max-outgoing:0

```

1.4.26 Class "Performance"

ADONIS BPMS BP Library 3.9:

```

CARDINALITIES
RELATION "has Cross-reference"
FROM_CLASS "Cross-reference"
max-incoming:1000
TO_CLASS "Cross-reference"
max-outgoing:1000
FROM_CLASS "Trigger"
max-incoming:0

```

Part IV

```
TO_CLASS "Trigger"
max-outgoing:0
FROM_CLASS "Process start"
max-incoming:0
TO_CLASS "Process start"
max-outgoing:0
FROM_CLASS "Subprocess"
max-incoming:0
TO_CLASS "Subprocess"
max-outgoing:0
FROM_CLASS "Activity"
max-incoming:0
TO_CLASS "Activity"
max-outgoing:0
FROM_CLASS "Decision"
max-incoming:0
TO_CLASS "Decision"
max-outgoing:0
FROM_CLASS "Parallelity"
max-incoming:0
TO_CLASS "Parallelity"
max-outgoing:0
FROM_CLASS "Merging"
max-incoming:0
TO_CLASS "Merging"
max-outgoing:0
FROM_CLASS "End"
max-incoming:0
TO_CLASS "End"
max-outgoing:0
FROM_CLASS "Variable"
max-incoming:0
TO_CLASS "Variable"
max-outgoing:0
FROM_CLASS "Random generator"
max-incoming:0
TO_CLASS "Random generator"
max-outgoing:0
FROM_CLASS "Resource"
max-incoming:0
TO_CLASS "Resource"
max-outgoing:0
FROM_CLASS "Performance indicator overview"
max-incoming:0
TO_CLASS "Performance indicator overview"
max-outgoing:0
FROM_CLASS "Performance indicator"
max-incoming:0
TO_CLASS "Performance indicator"
max-outgoing:0
FROM_CLASS "Note"
max-incoming:0
TO_CLASS "Note"
max-outgoing:0
FROM_CLASS "Aggregation"
max-incoming:0
TO_CLASS "Aggregation"
max-outgoing:0
FROM_CLASS "Document"
max-incoming:0
TO_CLASS "Document"
```

```

max-outgoing:0
FROM_CLASS "Document"
max-incoming:0
TO_CLASS "Document"
max-outgoing:0
FROM_CLASS "actor"
max-incoming:0
TO_CLASS "actor"
max-outgoing:0
FROM_CLASS "use case"
max-incoming:0
TO_CLASS "use case"
max-outgoing:0
FROM_CLASS "system boundary"
max-incoming:0
TO_CLASS "system boundary"
max-outgoing:0
FROM_CLASS "system boundary"
max-incoming:0
TO_CLASS "system boundary"
max-outgoing:0
FROM_CLASS "Process"
max-incoming:0
TO_CLASS "Process"
max-outgoing:0
FROM_CLASS "Performance"
max-incoming:0
TO_CLASS "Performance"
max-outgoing:0
FROM_CLASS "External partner"
max-incoming:0
TO_CLASS "External partner"
max-outgoing:0
FROM_CLASS "Product"
max-incoming:0
TO_CLASS "Product"
max-outgoing:0
FROM_CLASS "Product component"
max-incoming:0
TO_CLASS "Product component"
max-outgoing:0
FROM_CLASS "Application"
max-incoming:0
TO_CLASS "Application"
max-outgoing:0
FROM_CLASS "Service"
max-incoming:0
TO_CLASS "Service"
max-outgoing:0
FROM_CLASS "Infrastructure element"
max-incoming:0
TO_CLASS "Infrastructure element"
max-outgoing:0

```

1.4.27 Class "Infrastructure element"

ADONIS BPMS BP Library 3.9:

CARDINALITIES

Part IV

```
RELATION "has Cross-reference"  
FROM_CLASS "Cross-reference"  
max-incoming:1000  
TO_CLASS "Cross-reference"  
max-outgoing:1000  
FROM_CLASS "Trigger"  
max-incoming:0  
TO_CLASS "Trigger"  
max-outgoing:0  
FROM_CLASS "Process start"  
max-incoming:0  
TO_CLASS "Process start"  
max-outgoing:0  
FROM_CLASS "Subprocess"  
max-incoming:0  
TO_CLASS "Subprocess"  
max-outgoing:0  
FROM_CLASS "Activity"  
max-incoming:0  
TO_CLASS "Activity"  
max-outgoing:0  
FROM_CLASS "Decision"  
max-incoming:0  
TO_CLASS "Decision"  
max-outgoing:0  
FROM_CLASS "Parallelity"  
max-incoming:0  
TO_CLASS "Parallelity"  
max-outgoing:0  
FROM_CLASS "Merging"  
max-incoming:0  
TO_CLASS "Merging"  
max-outgoing:0  
FROM_CLASS "End"  
max-incoming:0  
TO_CLASS "End"  
max-outgoing:0  
FROM_CLASS "Variable"  
max-incoming:0  
TO_CLASS "Variable"  
max-outgoing:0  
FROM_CLASS "Random generator"  
max-incoming:0  
TO_CLASS "Random generator"  
max-outgoing:0  
FROM_CLASS "Resource"  
max-incoming:0  
TO_CLASS "Resource"  
max-outgoing:0  
FROM_CLASS "Performance indicator overview"  
max-incoming:0  
TO_CLASS "Performance indicator overview"  
max-outgoing:0  
FROM_CLASS "Performance indicator"  
max-incoming:0  
TO_CLASS "Performance indicator"  
max-outgoing:0  
FROM_CLASS "Note"  
max-incoming:0  
TO_CLASS "Note"  
max-outgoing:0
```



```
FROM_CLASS "Aggregation"
max-incoming:0
TO_CLASS "Aggregation"
max-outgoing:0
FROM_CLASS "Document"
max-incoming:0
TO_CLASS "Document"
max-outgoing:0
FROM_CLASS "Document"
max-incoming:0
TO_CLASS "Document"
max-outgoing:0
FROM_CLASS "actor"
max-incoming:0
TO_CLASS "actor"
max-outgoing:0
FROM_CLASS "use case"
max-incoming:0
TO_CLASS "use case"
max-outgoing:0
FROM_CLASS "system boundary"
max-incoming:0
TO_CLASS "system boundary"
max-outgoing:0
FROM_CLASS "system boundary"
max-incoming:0
TO_CLASS "system boundary"
max-outgoing:0
FROM_CLASS "Process"
max-incoming:0
TO_CLASS "Process"
max-outgoing:0
FROM_CLASS "Performance"
max-incoming:0
TO_CLASS "Performance"
max-outgoing:0
FROM_CLASS "External partner"
max-incoming:0
TO_CLASS "External partner"
max-outgoing:0
FROM_CLASS "Product"
max-incoming:0
TO_CLASS "Product"
max-outgoing:0
FROM_CLASS "Product component"
max-incoming:0
TO_CLASS "Product component"
max-outgoing:0
FROM_CLASS "Application"
max-incoming:0
TO_CLASS "Application"
max-outgoing:0
FROM_CLASS "Service"
max-incoming:0
TO_CLASS "Service"
max-outgoing:0
FROM_CLASS "Infrastructure element"
max-incoming:0
TO_CLASS "Infrastructure element"
max-outgoing:0
```

1.4.28 Class "Cost center"

ADONIS BPMS WE Library 3.9:

CARDINALITIES
RELATION "Is cost center manager"
max-incoming:1

1.5 Conversion

The class attribute "Conversion" is defined for the following **Classes of the ADONIS BPMS BP Library 3.9:**



Subprocess (see chap. 1.5.1, p. 512)

Activity (see chap. 1.5.2, p. 513)

Hint: The class attribute "Conversion" is not defined for the **Relation classes of the ADONIS BPMS BP Library 3.9.**

Hint: The class attribute "Conversion" is not defined for the **Classes of the ADONIS BPMS WE Library 3.9.**

Hint: The class attribute "Conversion" is not defined for the **Relation classes of the ADONIS BPMS WE Library 3.9.**

1.5.1 Class "Subprocess"

ADONIS BPMS BP Library 3.9:

```
CLASS "Activity"  
ATTR "Name"  
ATTR "Order"  
ATTR "Description"  
ATTR "Comment"  
ATTR "Open questions"  
ATTR "Execution time" from:"Aggregated execution time"  
ATTR "Waiting time" from:"Aggregated waiting time"  
ATTR "Resting time" from:"Aggregated resting time"  
ATTR "Transport time" from:"Aggregated transport time"  
ATTR "Costs" from:"Aggregated costs"  
ATTR "referenced subprocess" from:"Referenced subprocess"  
ATTR "Language"  
ATTR "Bezeichnung"  
ATTR "Beschreibung"  
ATTR "Kommentar"  
ATTR "Performer"  
ATTR "Responsible role"  
ATTR "Classification"  
ATTR "External documentation"  
ATTR "Referenced documents"  
ATTR "Referenced use cases"  
ATTR "Responsible for execution"  
ATTR "Accountable for approving results"  
ATTR "Cooperation/participation"  
ATTR "To inform"  
ATTR "Display responsible role"  
ATTR "Input"
```

```

ATTR "Output"
ATTR "Referenced IT system elements"
ATTR "Visualise referenced IT system elements"
ATTR "Referenced products"
ATTR "Responsible role"

```

1.5.2 Class "Activity"

ADONIS BPMS BP Library 3.9:

```

CLASS "Subprocess"
ATTR "Name"
ATTR "Order"
ATTR "Description"
ATTR "Comment"
ATTR "Open questions"
ATTR "Referenced subprocess" from:"referenced subprocess"
ATTR "Language"
ATTR "Bezeichnung"
ATTR "Beschreibung"
ATTR "Kommentar"
ATTR "Performer"
ATTR "Responsible role"
ATTR "Classification"
ATTR "External documentation"
ATTR "Referenced documents"
ATTR "Referenced use cases"
ATTR "Responsible for execution"
ATTR "Accountable for approving results"
ATTR "Cooperation/participation"
ATTR "To inform"
ATTR "Display responsible role"
ATTR "Input"
ATTR "Output"
ATTR "Referenced IT system elements"
ATTR "Visualise referenced IT system elements"
ATTR "Referenced products"
ATTR "Responsible role"

```

1.6 Allowed objects

The class attribute "Allowed objects" is defined for the following **Classes of the ADONIS BPMS BP Library 3.9:**



Swimlane (horizontal) (see chap. 1.6.1, p. 514)



Swimlane (vertical) (see chap. 1.6.2, p. 514)

Hint: The class attribute "Allowed objects" is not defined for the **Relation classes of the ADONIS BPMS BP Library 3.9.**

The class attribute "Allowed objects" is defined for the following **Classes of the ADONIS BPMS WE Library 3.9:**



Swimlane (horizontal) (see chap. 1.6.3, p. 514)



Swimlane (vertical) (see chap. 1.6.4, p. 514)

Hint: The class attribute "Allowed objects" is not defined for the **Relation classes of the ADONIS BPMS WE Library 3.9.**

1.6.1 Class "Swimlane (horizontal)"

ADONIS BPMS BP Library 3.9:

ALLOWED from:all

1.6.2 Class "Swimlane (vertical)"

ADONIS BPMS BP Library 3.9:

ALLOWED from:all

1.6.3 Class "Swimlane (horizontal)"

ADONIS BPMS WE Library 3.9:

ALLOWED from:all

1.6.4 Class "Swimlane (vertical)"

ADONIS BPMS WE Library 3.9:

ALLOWED from:all

2. Library attributes

- **Kapitel "Description"**
 - Keywords (see chap. 2.1, p. 516)
 - Description (see chap. 2.2, p. 516)
 - Comment (see chap. 2.3, p. 516)
 - Service (see chap. 2.4, p. 516)
 - Author (see chap. 2.5, p. 517)
 - Creation date (see chap. 2.6, p. 517)
 - Last user (see chap. 2.7, p. 517)
 - Date last changed (see chap. 2.8, p. 517)
- **Kapitel "Add-ons"**
 - Modi (see chap. 2.9, p. 517)
 - Versioning format (see chap. 2.10, p. 523)
 - External coupling (see chap. 2.11, p. 523)
- **Kapitel "Modeling"**
 - Default settings (see chap. 2.12, p. 533)
 - Page layouts (see chap. 2.13, p. 534)
 - Connector marks - Numbering (see chap. 2.14, p. 534)
 - Connector marks - Graphical representation (see chap. 2.15, p. 534)
 - Object arrangement (see chap. 2.16, p. 534)
- **Kapitel "Analysis"**
 - Relation analysis (see chap. 2.17, p. 536)
- **Kapitel "Simulation"**
 - Simulation definition - Simtext (see chap. 2.18, p. 537)
 - Simulation definition - Simmapping (see chap. 2.19, p. 537)
 - Simulation definition - Sim result mapping (see chap. 2.20, p. 538)
 - Simulation definition - Variable check (see chap. 2.21, p. 539)
 - Agent definition (see chap. 2.22, p. 539)
 - Enterprise time - Days per year (see chap. 2.23, p. 547)
 - Enterprise time - Hours per day (see chap. 2.24, p. 547)
- **Kapitel "Evaluation"**
 - Activity based costing - CCC mapping (see chap. 2.25, p. 548)
 - Activity based costing - CCC default settings (see chap. 2.26, p. 548)
 - Dynamic evaluation modules (see chap. 2.27, p. 548)
- **Kapitel "Documentation"**

Part IV

- Configuration of documentation (see chap. 2.28, p. 548)

2.1 Keywords (Description)

ADONIS BPMS BP Library 3.9:

ADONIS-BPMS-library for ADONIS version 3.9

ADONIS BPMS WE Library 3.9:

ADONIS-BPMS-working-environment-library for ADONIS version 3.9

2.2 Description (Description)

ADONIS BPMS BP Library 3.9:

This BP-library is defined for ADONIS version 3.9. It contains the modeltypes:

- 'Company map'
- 'Business process model'
- 'Document model'
- 'Use case diagram'
- 'Product model'
- 'IT system model'.

ADONIS BPMS WE Library 3.9:

This WE library is defined for ADONIS version 3.9. It contains the model type 'Working environment model'.

2.3 Comment (Description)

ADONIS BPMS BP Library 3.9:

This library is defined for use under the operating system MS Windows, because certain GraphRep attributes require the font "Wingdings".

ADONIS BPMS WE Library 3.9:

This library is defined for being used under the operating system MS Windows, since any GraphRep attributes require the font "Wingdings".

2.4 Service (Description)

ADONIS BPMS BP Library 3.9:

Address:

BOC ITC Ltd
80 Haddington Road
Dublin 4, Ireland
www.boc-group.com
Hotline (email):
hotline@boc-eu.com

ADONIS BPMS WE Library 3.9:

This attribute is not used in the ADONIS BPMS WE Library 3.9.

2.5 Author (Description)

ADONIS BPMS BP Library 3.9:

Admin

ADONIS BPMS WE Library 3.9:

Admin

2.6 Creation date (Description)

ADONIS BPMS BP Library 3.9:

26.07.2006, 10:57

ADONIS BPMS WE Library 3.9:

26.07.2006, 10:57

2.7 Last user (Description)

ADONIS BPMS BP Library 3.9:

Admin

ADONIS BPMS WE Library 3.9:

Admin

2.8 Date last changed (Description)

ADONIS BPMS BP Library 3.9:

26.07.2006, 10:58

ADONIS BPMS WE Library 3.9:

26.07.2006, 10:58

2.9 Modi (Add-ons)

ADONIS BPMS BP Library 3.9:

```
GENERAL order-of-classes:custom
METHOD graphRep:"Method GraphRep"
{
```

Part IV

```
#-----
GROUP "BPMS process phases"
{
  MODELTYPE "Product model"
  MODELTYPE "Company map"
  MODELTYPE "Business process model"
  MODELTYPE "Working environment model"
  MODELTYPE "IT system model"
  MODELTYPE "Use case diagram"
  MODELTYPE "Document model"
}
GROUP "Strategic decision process"
{
  MODELTYPE "Product model"
  MODELTYPE "Company map"
}
GROUP "Reengineering process"
{
  MODELTYPE "Product model"
  MODELTYPE "Company map"
  MODELTYPE "Business process model"
  MODELTYPE "Working environment model"
  MODELTYPE "Document model"
}
GROUP "Resource allocation process"
{
  MODELTYPE "Business process model"
  MODELTYPE "Working environment model"
  MODELTYPE "IT system model"
  MODELTYPE "Use case diagram"
  MODELTYPE "Document model"
}
GROUP "Workflow process"
{
  MODELTYPE "IT system model"
  MODELTYPE "Use case diagram"
}
GROUP "Performance evaluation process"
{
  MODELTYPE "Product model"
  MODELTYPE "Business process model"
  MODELTYPE "Working environment model"
}
#-----
GROUP "BPMS core elements"
{
  MODELTYPE "Product model"
  MODELTYPE "Company map"
  MODELTYPE "Business process model"
  MODELTYPE "Working environment model"
  MODELTYPE "IT system model"
  MODELTYPE "Use case diagram"
  MODELTYPE "Document model"
}
GROUP "Products"
{
  MODELTYPE "Product model"
}
GROUP "Business processes"
{
  MODELTYPE "Company map"
```



```

    MODELTYPE "Business process model"
  }
GROUP "Organisation"
{
  MODELTYPE "Working environment model"
}
GROUP "Information technology"
{
  MODELTYPE "IT system model"
  MODELTYPE "Use case diagram"
  MODELTYPE "Document model"
}
}
MODELTYPE "Product model" from:none plural:"Product models" pos:0 not-
simulateable attrrep:"BP Model Attributes" graphrep:"BP Model Graphrep" bit-
map:"db:\\prod.bmp"
INCL "Product"
INCL "Product component"
INCL "has "
INCL "Performance indicator"
INCL "Performance indicator overview"
INCL "Owns"
INCL "Note"
INCL "Aggregation"
INCL "has Note"
INCL "Is inside"
INCL "Swimlane (vertical)"
INCL "Swimlane (horizontal)"
INCL "Cross-reference"
INCL "has Cross-reference"
MODE "Standard" from:all
EXCL "Performance indicator"
EXCL "Performance indicator overview"
EXCL "Owns"
MODE "Standard - including Performance indicators" from:all
MODE "Documentation" from:all no-modeling
MODELTYPE "Company map" from:none plural:"Company maps" pos:1 not-simulateable
bitmap:"db:\\compmap.bmp" attrrep:"BP Model Attributes" graphrep:"BP Model Gra-
phrep"
INCL "Process"
INCL "Performance"
INCL "actor"
INCL "External partner"
INCL "Aggregation"
INCL "Note"
INCL "Has process"
INCL "Is inside"
INCL "has Note"
INCL "Performance indicator overview"
INCL "Performance indicator"
INCL "Owns"
INCL "Value flow"
INCL "Swimlane (vertical)"
INCL "Swimlane (horizontal)"
INCL "Cross-reference"
INCL "has Cross-reference"
MODE "Standard" from:all
EXCL "Performance indicator overview"
EXCL "Performance indicator"
EXCL "Owns"
MODE "Standard - including Performance indicators" from:"Standard"

```

Part IV

```
INCL "Performance indicator overview"
INCL "Performance indicator"
INCL "Owns"
    MODE "All modeling objects" from:"Standard"
INCL "Performance indicator overview"
INCL "Performance indicator"
INCL "Owns"
MODE "Documentation" from:all no-modeling
MODELTYPE "Business process model" from:none plural:"Business process models"
pos:2 attrrep:"BPM Model Attributes" graphrep:"BPM Model Graphrep"
INCL "Swimlane (horizontal)"
INCL "Swimlane (vertical)"
INCL "Trigger"
INCL "Process start"
INCL "Subprocess"
INCL "Activity"
INCL "Decision"
INCL "Parallelity"
INCL "Merging"
INCL "End"
INCL "Variable"
INCL "Random generator"
INCL "Resource"
INCL "Note"
INCL "Aggregation"
INCL "Cross-reference"
INCL "Performance indicator overview"
INCL "Performance indicator"
INCL "Subsequent"
INCL "Sets variable"
INCL "Sets"
INCL "Uses"
INCL "has Note"
INCL "has Cross-reference"
INCL "Owns"
MODE "Flow" from:all
EXCL "Variable"
EXCL "Random generator"
EXCL "Resource"
EXCL "Performance indicator"
EXCL "Performance indicator overview"
EXCL "Sets variable"
EXCL "Sets"
EXCL "Uses"
MODE "Flow - including Variables and Random generators" from:"Flow"
INCL "Variable"
INCL "Random generator"
INCL "Sets variable"
INCL "Sets"
MODE "Flow - including Resources" from:"Flow"
INCL "Resource"
INCL "Uses"
MODE "Flow - including Performance indicators" from:"Flow"
INCL "Performance indicator overview"
INCL "Performance indicator"
INCL "Owns"
MODE "All modelling objects" from:all
MODE "Documentation" from:all no-modeling
MODELTYPE "IT system model" from:none plural:"IT system models" pos:4 not-
simulateable attrrep:"BP Model Attributes" bitmap:"db:\\itsys.bmp" graphrep:"BP
Model Graphrep"
```

```

INCL "Application"
INCL "Service"
INCL "Infrastructure element"
INCL "has"
INCL "uses "
INCL "Is dependent on"
INCL "Performance indicator"
INCL "Performance indicator overview"
INCL "Owns"
INCL "Note"
INCL "Aggregation"
INCL "has Note"
INCL "Is inside"
INCL "Swimlane (vertical)"
INCL "Swimlane (horizontal)"
INCL "Cross-reference"
INCL "has Cross-reference"
MODE "Standard" from:all
EXCL "Performance indicator"
EXCL "Performance indicator overview"
EXCL "Owns"
MODE "Service overview" from:all
EXCL "Application"
EXCL "Infrastructure element"
EXCL "Performance indicator"
EXCL "Performance indicator overview"
EXCL "Owns"
MODE "Application overview" from:all
EXCL "Service"
EXCL "Infrastructure element"
EXCL "Performance indicator"
EXCL "Performance indicator overview"
EXCL "Owns"
MODE "Infrastructure element overview" from:all
EXCL "Service"
EXCL "Application"
EXCL "Performance indicator"
EXCL "Performance indicator overview"
EXCL "Owns"
MODE "Standard - including Performance indicators" from:all
MODE "Documentation" from:all no-modeling
MODELTYPE "Use case diagram" from:none plural:"Use case diagrams" pos:5 not-
simulateable attrrep:"BP Model Attributes" bitmap:"db:\\uml_use.bmp" graphrep:"BP
Model Graphrep"
  INCL "actor"
  INCL "use case"
  INCL "system boundary"
  INCL "Note"
  INCL "communicates"
    INCL "contains"
    INCL "uses"
    INCL "extends"
  INCL "has Note"
  INCL "Is inside"
  INCL "Generalisation"
  INCL "Cross-reference"
  INCL "has Cross-reference"
  INCL "Swimlane (vertical)"
  INCL "Swimlane (horizontal)"
MODE "Standard" from:all
MODE "Documentation" from:all no-modeling

```

Part IV

```
MODELTYPE "Document model" from:none plural:"Document models" pos:6 not-
simulateable bitmap:"db:\\doc_mod.bmp" attrrep:"BP Model Attributes" graphrep:"BP
Model Graphrep"
  INCL "Document"
  INCL "Aggregation"
  INCL "Note"
  INCL "has Subdocument"
  INCL "has Note"
  INCL "Cross-reference"
  INCL "has Cross-reference"
  INCL "Swimlane (vertical)"
  INCL "Swimlane (horizontal)"
  MODE "Standard" from:all
MODE "Documentation" from:all no-modeling
```

ADONIS BPMS WE Library 3.9:

```
MODELTYPE "Working environment model" from:none plural:"Working environment models"
pos:3 attrrep:"WE Model Attributes" graphrep:"BP Model Graphrep"
  INCL "Organizational unit"
  INCL "Performer"
  INCL "Role"
  INCL "Position"
  INCL "Resource"
  INCL "Cost center"
  INCL "Aggregation"
  INCL "Note"
  INCL "Is subordinated"
  INCL "has Resource"
  INCL "Belongs to"
  INCL "Is manager"
  INCL "Has role"
  INCL "has position"
  INCL "Uses resource"
  INCL "Is charged to"
  INCL "Is cost center manager"
  INCL "has Note"
  INCL "Swimlane (vertical)"
  INCL "Swimlane (horizontal)"
  MODE "Standard" from:all
  EXCL "Resource"
  EXCL "Cost center"
  EXCL "Position"
  MODE "Standard - including Resources" from:all
  EXCL "Cost center"
  EXCL "Position"
  MODE "Standard - with cost center" from:all
  EXCL "Resource"
  EXCL "Position"
  MODE "Organization" from:all
  EXCL "Performer"
  EXCL "Role"
  EXCL "Resource"
  EXCL "Cost center"
  MODE "Role diagram" from:all
  EXCL "Organizational unit"
  EXCL "Performer"
  EXCL "Position"
  EXCL "Resource"
  EXCL "Cost center"
  MODE "Resource diagram" from:all
```

```

EXCL "Role"
EXCL "Belongs to"
EXCL "Is manager"
EXCL "Position"
EXCL "Cost center"
MODE "All modeling objects" from:all
MODE "Documentation" from:all no-modeling

```

2.10 Versioning format (Add-ons)

ADONIS BPMS BP Library 3.9:

This attribute is not used in the ADONIS BPMS BP Library 3.9.

ADONIS BPMS WE Library 3.9:

This attribute is not used in the ADONIS BPMS WE Library 3.9.

2.11 External coupling (Add-ons)

ADONIS BPMS BP Library 3.9:

```

#=====
#---- INIT GLOBAL VARS
ON_EVENT "AppInitialized"
{
  #Type check is on
  CC "AdoScript" SET_MP_TYPE_CHECKING on
  IF (type(_uilang) = "undefined")
  {
    SET _uilang:"en"
  }
  IF (_uilang = "de")
  {
    #init start string in german (default)
    SETG c_str_TEXT_LOADING_SETTINGS:"Einstellungen laden..."
    SETG c_str_ERROR_CUST_DIR_NOT_FOUND:"Der Pfad zum Kundenverzeichnis konnte
nicht ermittelt werden. AdoScript-Funktionalitäten können nicht verwendet werden!"
    SETG c_str_ERROR_ASC_NOT_FOUND:"AdoScript konnte nicht initialisiert werden.
AdoScript-Funktionalitäten können nicht verwendet werden!"
    SETG c_str_ERROR_ASC_LIB_INCOMPATIBLE:"Die verwendete AdoScript Bibliothek ist
nicht kompatibel. Vewendete AdoScripten funktionieren möglicherweise nicht."
    #process stepper
    SETG process_stepper_bearbzeit_state:"aktiviert"
    SETG g_b_ps_printProcessingTime:1
    SETG g_str_ps_speed:"mittel"
    #global language file
    SETG c_str_GLOBAL_LANGUAGE_FILE:"script_globals_de.asc"
  }
  ELSE
  {
    #init start string in english
    SETG c_str_TEXT_LOADING_SETTINGS:"Loading settings..."
    SETG c_str_ERROR_CUST_DIR_NOT_FOUND:"The path to the customer directory could
not be determined. AdoScript-AddOn capabilities are not available."
    SETG c_str_ERROR_ASC_NOT_FOUND:"AdoScript could not be initialized. AdoScript-
AddOn capabilities are not available."
  }
}

```

Part IV

```
SETG c_str_ERROR_ASC_LIB_INCOMPATIBLE:"The assigned AdoScript library is not
compatible. AdoScript-AddOn capabilities are not available."
#process stepper
SETG process_stepper_bearzeit_state:"activated"
SETG g_b_ps_printProcessingTime:1
SETG g_str_ps_speed:"medium"
#global language file
SETG c_str_GLOBAL_LANGUAGE_FILE:"script_globals_en.asc"
}
CC "AdoScript" MSGWIN hide
CC "AdoScript" MSGWIN (c_str_TEXT_LOADING_SETTINGS)
#-----
-
# initialization of global parameters
#-----
-
#general settings
SETG g_path_asc:"db:\\\"
SETG g_b_filesInDB:1
# declare and init label for const strings
SETG g_b_strings_initialized:0
# declare path variable to ADONIS
SETG g_path_ado:""
#Get path to ADONIS
CC "Application" GET_PATH
# [GSp, 2006.03.29] check if application path is not a root path (e.g. l:\), if
so cut of trailing \
IF (copy (path,(LEN path)-1,1) = "\\")
{
  SET path:(copy (path,0,(LEN path)-1))
}
SET g_path_ado:(path)
#-----
# initialization of global language settings
#-----
CC "AdoScript" FILE_EXIST file:(g_path_asc + c_str_GLOBAL_LANGUAGE_FILE)
#-->RESULT exist:[0|1]
IF (NOT exist)
{
  CC "AdoScript" MSGWIN hide
  CC "AdoScript" ERRORBOX (c_str_ERROR_ASC_NOT_FOUND)
  EXIT
}
EXECUTE file:(g_path_asc + c_str_GLOBAL_LANGUAGE_FILE)
#-----
-
# init file for language visualization (drawing area)
#-----
-
CC "AdoScript" FILE_EXIST file:(g_path_asc + "lang_views.asc")
#-->RESULT exist:[0|1]
IF (NOT exist)
{
  CC "AdoScript" MSGWIN hide
  CC "AdoScript" ERRORBOX (c_str_ERROR_ASC_NOT_FOUND)
  EXIT
}
EXECUTE file:(g_path_asc + "lang_views.asc")
#-----
-
# set AdoScript HDL for html icon
```

```

#-----
-
CC "Application" raw SET_ICON_CLICK_HDL component:"importexport" name:"HTML"
{
  CC "AdoScript" FILE_EXIST file:(g_path_asc + "make_html.asc")
  #-->RESULT exist:[0|1]
  IF (NOT exist)
  {
    CC "AdoScript" ERRORBOX (c_str_ERROR_ASC_NOT_FOUND)
    EXIT
  }
  EXECUTE file:(g_path_asc + "make_html.asc")
}
CC "Application" INSERT_ICON component:"importexport" pos:4 name:"WORD"
                                bitmap:"db:\\word.bmp" text:"WORD generation"
#-----
-
# set AdoScript HDL for rtf/word icon
#-----
-
CC "Application" SET_ICON_CLICK_HDL name:"WORD"
{
  CC "AdoScript" FILE_EXIST file:(g_path_asc + "make_rtf.asc")
  #-->RESULT exist:[0|1]
  IF (NOT exist)
  {
    CC "AdoScript" ERRORBOX (c_str_ERROR_ASC_NOT_FOUND)
    EXIT
  }
  EXECUTE file:(g_path_asc + "make_rtf.asc")
}
CC "Application" SET_ICON_VISIBLE component:"importexport" name:"DOCU" visi-
ble:0
  #Lists
  SETG g_lst_models_loaded:""
  #?!?
  #Booleans
  SETG g_b_dang_ref_fnd:0
# declare used lib version and dependencies
  SETG g_n_this_lib_vers:4
  SETG g_n_this_version_level:0
# declares error handler var
  SETG g_b_aborted:0
  #?!?
# declares global list of loaded variables
  SETG g_lst_loaded:""
# declare path variables to db
  SETG g_path_db:""
# declare and init customer directory var
  SETG g_dir_cust:"tmp"
# and customer path
  SETG g_path_home:""
# declare path variables to DSL
  SETG g_path_dsl:""
# declare path variables to other external files
  SETG g_path_ext:""
# init previously declared path vars
  SET g_path_db:("db:\\")
  SET g_path_home:(g_path_db)
  SET g_path_dsl:(g_path_db)
  SET g_path_ext:(g_path_db)

```

Part IV

```
#INCLUDE GENERAL LIB
CC "AdoScript" FREAD file:(g_path_asc + "lib_gen.asc")
IF (text = "")
{
  CC "AdoScript" ERRORBOX (c_str_ERROR_ASC_NOT_FOUND)
  EXIT
}
EXECUTE (text)
#Check lib version
CHECK_LIB_VERS (g_n_this_lib_vers)
                n_this_version_level:g_n_this_version_level
                b_this_aborted:g_b_aborted
IF (g_n_this_version_level < 1)
{
  CC "AdoScript" ERRORBOX (c_str_ERROR_ASC_LIB_INCOMPATIBLE)
  CC "AdoScript" MSGWIN hide
  EXIT
}
CC "AdoScript" MSGWIN hide
#INCLUDE DATE LIB
  CC "AdoScript" FREAD file:(g_path_asc + "lib_date.asc")
  IF(text = "")
  {
    CC "AdoScript" ERRORBOX (c_str_ERROR_ASC_NOT_FOUND)
    EXIT
  }
  EXECUTE (text)
  #INCLUDE BMF tools
CC "AdoScript" FREAD file:(g_path_asc + "tools.asc")
IF (text = "")
{
  CC "AdoScript" ERRORBOX (c_str_ERROR_ASC_NOT_FOUND)
  EXIT
}
EXECUTE (text)
#INCLUDE logging stuff
  CC "AdoScript" FREAD file:(g_path_asc + "logging.asc")
  IF(text = "")
  {
    CC "AdoScript" ERRORBOX (c_str_ERROR_ASC_NOT_FOUND)
    EXIT
  }
}
EXECUTE (text)
# load procedures for visualization
  CC "AdoScript" FILE_EXIST file:(g_path_asc + "script_visualization.asc")
  #-->RESULT exist:[0|1]
  IF (NOT exist)
  {
    CC "AdoScript" ERRORBOX (c_str_ERROR_ASC_NOT_FOUND)
    EXIT
  }
}
EXECUTE file:(g_path_asc + "script_visualization.asc")
# define global parameters for classid of swimlanes in bp-library
CC "Core" GET_CLASS_ID classname:(c_CLASS_NAME5) bp-library
#--> RESULT ecode:intValue classid:intValue isrel:intValue
SETG g_id_CLASSID_SWIMLANE_HORIZONTAL:(classid)
CC "Core" GET_CLASS_ID classname:(c_CLASS_NAME6) bp-library
#--> RESULT ecode:intValue classid:intValue isrel:intValue
SETG g_id_CLASSID_SWIMLANE_VERTICAL:(classid)
SETG g_b_ERROR_HANDLING:1
SETG g_b_strings_initialized:1
```



```

    CC "AdoScript" MSGWIN hide
}
#=====
ON_EVENT "AfterCreateModelingNode"
{
    # predefined values: modelid, objid, classid, origin
    IF ( (classid = g_id_CLASSID_SWIMLANE_HORIZONTAL) OR (classid =
g_id_CLASSID_SWIMLANE_VERTICAL) )
    {
        BP_SWIMLANE_CREATED id_modelid:(modelid)
                            id_objid:(objid)
                            id_classid:(classid)
                            n_origin:(origin)
    }
}
#=====
#--SIMULATION--#
#-----
ITEM separator
    simulation:"~Edit" simulation_de:"~Bearbeiten" pos2:4
#-----
#-----
ITEM "Activate manual random generator" name_de:"Manuelle Variablenbelegung ak-
tivieren"
    sub-of:"Random generator" sub-of_de:"Variablenbelegung" pos2:4
    simulation:"~Edit" simulation_de:"~Bearbeiten"
#-----
CC "AdoScript" FREAD file:(g_path_asc + "var_set_man.asc")
EXECUTE (text)
#-----
ITEM "Activate automatic random generator" name_de:"Automatische Variablenbelegung
aktivieren"
    sub-of:"Random generator" sub-of_de:"Variablenbelegung"
    simulation:"~Edit" simulation_de:"~Bearbeiten"
#-----
CC "AdoScript" FREAD file:(g_path_asc + "var_set_aut.asc")
EXECUTE (text)
#--IMPORT/EXPORT--#
#-----
ITEM "WORD generation..." name_de:"WORD-Generierung..."
    importexport:"~Documentation" importexport_de:"~Dokumentation" pos2:2
#-----
CC "AdoScript" FREAD file:(g_path_asc + "make_rtf.asc")
EXECUTE (text)
#-----
#ITEM "HTML Generation..." name_de:"HTML-Generierung..."
ITEM "HTML generation..." name_de:"HTML-Generierung..."
    importexport:"~Documentation" importexport_de:"~Dokumentation" pos2:2
#-----
CC "AdoScript" FREAD file:(g_path_asc + "make_html.asc")
EXECUTE (text)
#-----
ITEM "Attribute and class filter..." name_de:"Attribut- und Klassenfilter..."
    importexport:"~Documentation" importexport_de:"~Dokumentation" pos2:13
#-----
CC "Documentation" EXEC_ACFILTER attribute:"Attribute and class filter"
#--MODELING--#
#-----
ITEM "Hierarchical model copy..." name_de:"Tiefe Modellkopie (Modellbaum kop-
ieren)..."
    modeling:"~Model" modeling_de:"~Modell" pos2:6

```

Part IV

```
#-----
EXECUTE file:(g_path_asc + "script_deepModelCopy.asc")
#-----
ITEM "Inter-model references (multiple models)..." name_de:"Modellübergreifende
Referenzen (mehrere Modelle)..."
    modeling:"~Model" modeling_de:"~Modell" pos2:16
#-----
CC "AdoScript" FREAD file:(g_path_asc + "check_references_main.asc")
EXECUTE (text)
#-----
ITEM "Select attribute visualisation language..." name_de:"Sprache für die Attribu-
tanzeige auswählen..."
    sub-of:"Views" sub-of_de:"Sichten"
    modeling:"~View" modeling_de:"~Ansicht" pos2:4
#-----
DO_SWITCH_MODEL_LANG
#-----
ITEM "Monochrome view" name_de:"Monochrome Darstellung"
    sub-of:"Views" sub-of_de:"Sichten"
    modeling:"~View" modeling_de:"~Ansicht" pos2:4
#-----
IF (type(g_b_MONOCHROM_REPRESENTATION) = "undefined")
{
    SETG g_b_MONOCHROM_REPRESENTATION:0
}
IF (g_b_MONOCHROM_REPRESENTATION)
{
    # monochrom repretation in on -> turn off
    CC "Modeling" SET_COLOR_REPRESENTATION pen:"color" fill:"color" font:"color"
    SETG g_b_MONOCHROM_REPRESENTATION:0
    CC "Application" SET_MENU_ITEM_CHECKED component:"modeling" item:(cond (_uilang =
"en", "View\tViews\tMonochrome view", "Ansicht\tSichten\tMonochrome Darstellung"))
checked:0
}
ELSE
{
    # monochrom repretation in off -> turn on
    CC "Modeling" SET_COLOR_REPRESENTATION pen:"grayscale-dark" fill:"grayscale-
light" font:"black"
    SETG g_b_MONOCHROM_REPRESENTATION:1
    CC "Application" SET_MENU_ITEM_CHECKED component:"modeling" item:(cond (_uilang =
"en", "View\tViews\tMonochrome view", "Ansicht\tSichten\tMonochrome Darstellung"))
checked:1
}
#-----
ITEM "Display incorrect transition probability" name_de:"Fehlerhafte Übergangswahr-
scheinlichkeiten visualisieren"
    sub-of:"Views" sub-of_de:"Sichten"
    modeling:"~View" modeling_de:"~Ansicht" pos2:4
#-----
MENU_VISUALISATION_TOGGLE lBpClasses:"Decision"
    lWeClasses:""
    sAttr:("display incorrect transition probability")
    sAttrType:"string"
    sComponent:("modeling")
    sMenuEntry:(cond (_uilang = "en", "View\tViews\tDisplay
incorrect transition conditions", "Ansicht\tSichten\tFehlerhafte Übergangswahr-
scheinlichkeiten visualisieren"))
#-----
ITEM "Show responsible role" name_de:"Verantwortliche Rolle einblenden"
    sub-of:"Views" sub-of_de:"Sichten"
```

```

        modeling:"~View" modeling_de:"~Ansicht" pos2:4
#-----
SETG g_strRoleOption:(g_sYesValCapital)
CC "AdoScript" FREAD file:(g_path_asc + "show_responsible_role.asc")
EXECUTE (text)
#-----
ITEM "Hide responsible role" name_de:"Verantwortliche Rolle ausblenden"
      sub-of:"Views" sub-of_de:"Sichten"
      modeling:"~View" modeling_de:"~Ansicht" pos2:4
#-----
SETG g_strRoleOption:(g_sNoValCapital)
CC "AdoScript" FREAD file:(g_path_asc + "show_responsible_role.asc")
EXECUTE (text)
#-----
#ITEM "Visualise referenced IT system elements"
#   sub-of:"Views"
#   modeling:"~View" pos2:4
#-----
#MENU_VISUALISATION_TOGGLE lBpClasses:(g_lAllBPClasses)
#                               lWeClasses:""
#                               sAttr:("Visualise referenced IT system elements")
#                               sAttrType:"boolean"
#                               sComponent:("modeling")
#                               sMenuEntry:("View\tViews\tVisualise referenced IT system
elements...")
#-----
ITEM separator
sub-of:"Views" sub-of_de:"sichten"
      modeling:"~View" modeling_de:"Ansicht" pos2:4
#-----
#-----
ITEM "Show/hide reference overview" name_de:"Referenzenübersicht ein-/ausblenden"
      sub-of:"Views" sub-of_de:"Sichten"
      modeling:"~View" modeling_de:"~Ansicht" pos2:4
#-----
TOGGLE_NAVIGATION_OVERVIEW
#-----
ITEM "Configure reference overview..." name_de:"Referenzenübersicht konfigurieren..."
      sub-of:"Views" sub-of_de:"Sichten"
      modeling:"~View" modeling_de:"~Ansicht" pos2:4
#-----
TOGGLE_CONFIG_NAVIGATION_OVERVIEW
#-----
ITEM "Change modelling direction" name_de:"Modellierungsrichtung wechseln"
      sub-of:"Views" sub-of_de:"Sichten"
      modeling:"~View" modeling_de:"~Ansicht" pos2:4
#-----
TOGGLE_MOD_DIRECTION
#-----
ITEM separator
      sub-of:"Update attributes" sub-of_de:"Attribute aktualisieren"
      modeling:"~Edit" modeling_de:"~Bearbeiten" pos3:1
#-----
#-----
ITEM "Reset object numbering" name_de:"Objektnumerierung zurücksetzen"
      sub-of:"Update attributes" sub-of_de:"Attribute aktualisieren"
      modeling:"~Edit" modeling_de:"~Bearbeiten" pos3:1
#-----
CC "AdoScript" FREAD file:(g_path_asc + "reset_numbering.asc")
EXECUTE (text)

```

Part IV

```
##--EVALUATION--#
#-----
ITEM "Initialise current values..." name_de:"IST-Werte initialisieren..."
    evaluation:"~Monitoring" evaluation_de:"~Monitoring"
#-----
CC "AdoScript" FREAD file:(g_path_asc + "resettargets.asc")
EXECUTE (text)
#-----
ITEM "Calculate current values..." name_de:"IST-Werte aktualisieren..."
    evaluation:"~Monitoring" evaluation_de:"~Monitoring"
#-----
CC "AdoScript" FREAD file:(g_path_asc + "updactval.asc")
EXECUTE (text)
##--DIVERSE--#
#-----
ITEM "ADONIS-BPMS method" name_de:"ADONIS BPMS-Methode"
    acquisition:"~Help" acquisition_de:"~Hilfe"
    modeling:"~Help" modeling_de:"~Hilfe"
    analysis:"~Help" analysis_de:"~Hilfe"
    simulation:"~Help" simulation_de:"~Hilfe"
    evaluation:"~Help" evaluation_de:"~Hilfe"
    importexport:"~Help" importexport_de:"~Hilfe"
#-----
IF (_uilang = "de")
{
    CC "Application" GET_PATH "hilfe\\2057\\adostd.hlp"
}
ELSE
{
    CC "Application" GET_PATH "hilfe\\1031\\adostd.hlp"
}
START ("\" + path + "\"")
#-----
ITEM separator acquisition:"~Help" acquisition_de:"~Hilfe" pos2:5
ITEM separator modeling:"~Help" modeling_de:"~Hilfe" pos2:5
ITEM separator analysis:"~Help" analysis_de:"~Hilfe" pos2:5
ITEM separator simulation:"~Help" simulation_de:"~Hilfe" pos2:5
ITEM separator evaluation:"~Help" evaluation_de:"~Hilfe" pos2:5
ITEM separator importexport:"~Help" importexport_de:"~Hilfe" pos2:5
#-----
#-----
ITEM "BOC home page" name_de:"BOC-Homepage"
    acquisition:"~Help" acquisition_de:"~Hilfe" pos2:5
    modeling:"~Help" modeling_de:"~Hilfe" pos2:5
    analysis:"~Help" analysis_de:"~Hilfe" pos2:5
    simulation:"~Help" simulation_de:"~Hilfe" pos2:5
    evaluation:"~Help" evaluation_de:"~Hilfe" pos2:5
    importexport:"~Help" importexport_de:"~Hilfe" pos2:5
#-----
START ("http://www.boc-eu.com")
##-- P R O C E S S - S T E P P E R --#
#-----
# 1. Process animation
ITEM "1. Process animation" name_de:"1. Prozeßanimation" modeling:"~Process step-
per" modeling_de:"Prozeß-Stepper"
#-----
SETG parameter:(1)
CC "AdoScript" FREAD file:(g_path_asc + "stepper_animation.asc")
IF (text = "")
{
```

```

    CC "AdoScript" INFOBOX "The function can not be executed. The required external
files are not available."
    EXIT
}
EXECUTE (text)
#-----
# 2. Play-back process animation
ITEM "2. Play-back process animation..." name_de:"2. Prozeßanimation abspielen..."
modeling:"~Process stepper" modeling_de:"Prozeß-Stepper"
#-----
CC "AdoScript" FREAD file:(g_path_asc + "stepper_play.asc")
IF (text = "")
{
    CC "AdoScript" INFOBOX "The function can not be executed. The required external
files are not available."
    EXIT
}
EXECUTE (text)
#-----
# 3. Remove marking of objects
ITEM "3. Remove marking of objects" name_de:"3. Objektmarkierungen entfernen" mod-
eling:"~Process stepper" modeling_de:"Prozeß-Stepper"
#-----
CC "AdoScript" FREAD file:(g_path_asc + "undye_all_obj.asc")
IF (text = "")
{
    CC "AdoScript" INFOBOX "The function can not be executed. The required external
files are not available."
    EXIT
}
EXECUTE (text)
#-----
ITEM separator modeling:"~Process stepper" modeling_de:"Prozeß-Stepper"
#-----
# Settings
ITEM "Settings..." name_de:"Einstellungen..." modeling:"~Process stepper" model-
ing_de:"Prozeß-Stepper"
#-----
SETG global_check:"yes"
SETG namegeneration_running:"yes"
CC "AdoScript" FREAD file:(g_path_asc + "stepper_settings_dlg.asc")
EXECUTE (text)
SETG global_check:"no"
SETG namegeneration_running:"no"
#-----
# 5. Execution time
# ITEM "Execution time" sub-of:"Settings" modeling:"~Process stepper" model-
ing_de:"Prozeß-Stepper"
#-----
# SETG global_check:"yes"
# SETG namegeneration_running:"yes"
# CC "AdoScript" FREAD file:(g_path_asc + "stepper_settings_bearbeitung.asc")
# EXECUTE (text)
# SETG global_check:"no"
# SETG namegeneration_running:"no"
#--EXTERNAL COUPLING--#
#-----
# CI
#
#

```

Part IV

```
#-----  
#-----  
# Create CI  
#-----  
ITEM "Create CI" name_de:"CI erstellen"  
  sub-of:"Corporate Identity (CI)..." sub-of_de:"Corporate Identity (CI)..."  
pos2:4  
  importexport:"~Documentation" importexport_de:"~Dokumentation" pos2:2  
  CC "AdoScript" FREAD file:("db:\\ci.asc")  
  IF (text = "" OR ecode != 0)  
  {  
    CC "AdoScript" ERRORBOX (c_str_ERROR_ASC_NOT_FOUND)  
  }  
  ELSE  
  {  
    EXECUTE (text)  
    CI_ADD  
  }  
#-----  
# Delete CI  
#-----  
ITEM "Delete CI" name_de:"CI löschen"  
  sub-of:"Corporate Identity (CI)..." sub-of_de:"Corporate Identity (CI)..."  
pos2:4  
  importexport:"~Documentation" importexport_de:"~Dokumentation" pos2:2  
  CC "AdoScript" FREAD file:("db:\\ci.asc")  
  IF (text = "" OR ecode != 0)  
  {  
    CC "AdoScript" ERRORBOX (c_str_ERROR_ASC_NOT_FOUND)  
  }  
  ELSE  
  {  
    EXECUTE (text)  
    CI_DELETE  
  }  
#-----  
# Edit CI  
#-----  
ITEM "Edit CI" name_de:"CI bearbeiten"  
  sub-of:"Corporate Identity (CI)..." sub-of_de:"Corporate Identity (CI)..."  
pos2:4  
  importexport:"~Documentation" importexport_de:"~Dokumentation" pos2:2  
  CC "AdoScript" FREAD file:("db:\\ci.asc")  
  IF (text = "" OR ecode != 0)  
  {  
    CC "AdoScript" ERRORBOX (c_str_ERROR_ASC_NOT_FOUND)  
  }  
  ELSE  
  {  
    EXECUTE (text)  
    CI_MODIFY  
  }  
#-----  
# CI default  
#-----  
ITEM "Set Default CI" name_de:"Standard-CI wählen"  
  sub-of:"Corporate Identity (CI)..." sub-of_de:"Corporate Identity (CI)..."  
pos2:4  
  importexport:"~Documentation" importexport_de:"~Dokumentation" pos2:2  
  CC "AdoScript" FREAD file:("db:\\ci.asc")  
  IF (text = "" OR ecode != 0)
```

```

{
  CC "AdoScript" ERRORBOX (c_str_ERROR_ASC_NOT_FOUND)
}
ELSE
{
  EXECUTE (text)
  SET_DEFAULT_CI nEcode:nEcode
}
ITEM separator
  sub-of:"Corporate Identity (CI)..." sub-of_de:"Corporate Identity (CI)..."
pos2:4
  importexport:"-Documentation" importexport_de:"-Dokumentation" pos2:2
# -----
# CI Export
# -----
ITEM "CI Export" name_de:"CI-Export"
  sub-of:"Corporate Identity (CI)..." sub-of_de:"Corporate Identity (CI)..."
pos2:4
  importexport:"-Documentation" importexport_de:"-Dokumentation" pos2:2
  CC "AdoScript" FREAD file:("db:\\ci.asc")
  IF (text = "" OR ecode != 0)
  {
    CC "AdoScript" ERRORBOX (c_str_ERROR_ASC_NOT_FOUND)
  }
  ELSE
  {
    EXECUTE (text)
    CI_EXPORT
  }
# -----
# CI Import
# -----
ITEM "CI Import" name_de:"CI-Import"
  sub-of:"Corporate Identity (CI)..." sub-of_de:"Corporate Identity (CI)..."
pos2:4
  importexport:"-Documentation" importexport_de:"-Dokumentation" pos2:2
  CC "AdoScript" FREAD file:("db:\\ci.asc")
  IF (text = "" OR ecode != 0)
  {
    CC "AdoScript" ERRORBOX (c_str_ERROR_ASC_NOT_FOUND)
  }
  ELSE
  {
    EXECUTE (text)
    CI_IMPORT
  }
#-----
#OBJECTIF
#-----
#CLASS "Activity"

```

ADONIS BPMS WE Library 3.9:*This attribute is not used in the ADONIS BPMS WE Library 3.9.***2.12 Default settings (Modeling)****ADONIS BPMS BP Library 3.9:**

Part IV

```
GRID snap:on visible:off w:0.50cm h:0.50cm
GRADIENT_PRINTING mode:avg-color
```

ADONIS BPMS WE Library 3.9:

```
GRID snap:on visible:off w:0.5cm h:0.5cm
```

2.13 Page layouts (Modeling)

ADONIS BPMS BP Library 3.9:

```
LAYOUT "Full page (without header/footer)"
PAGE w:p h:p
```

ADONIS BPMS WE Library 3.9:

```
LAYOUT "Full page (without head-/footlines)"
PAGE w:p h:p
```

2.14 Connector marks - Numbering (Modeling)

ADONIS BPMS BP Library 3.9:

```
numeric
```

ADONIS BPMS WE Library 3.9:

```
numeric
```

2.15 Connector marks - Graphical representation (Modeling)

ADONIS BPMS BP Library 3.9:

```
GRAPHREP
FILL color:aliceblue
RECTANGLE x:-.3cm y:-.3cm w:.6cm h:.6cm
```

ADONIS BPMS WE Library 3.9:

```
GRAPHREP
FILL color:powderblue
RECTANGLE x:-.3cm y:-.3cm w:.6cm h:.6cm
```

2.16 Object arrangement (Modeling)

ADONIS BPMS BP Library 3.9:

```
DISABLE edit arrange
PROFILE "Standard (horizontal)" type:"std"
DEFMODELTYPE "Business process model"
DEFMODELTYPE "Company map"
MINCROSS upon upcount:10 dwnon dwncount:10
PENDULUM upon upcount:10 dwnon dwncount:10
```



```

FLIPFLY mirrhor toright
DOUBLEBP dist:3
CHNGSIZE vertdist:5 hordist:5
CLASSMODELTYPE "Business process model"
CLASSPAR "Subsequent" space:1 turn:0 priority:1
CLASSPAR "Sets" space:1 turn:1 priority:1
CLASSPAR "Uses" space:1 turn:0 priority:1
CLASSPAR "Sets variable" space:1 turn:0 priority:1
CLASSPAR "Uses" space:1 turn:0 priority:1
CLASSMODELTYPE "Company map"
CLASSPAR "Has process" space:1 turn:0 priority:1
PROFILE "Standard (vertikal)" type:"std"
DEFMODELTYPE "Business process model"
DEFMODELTYPE "Company map"
MINCROSS upon upcount:10 dwnon dwncount:10
PENDULUM upon upcount:10 dwnon dwncount:10
FLIPFLY dwn
DOUBLEBP dist:3
CHNGSIZE vertdist:5 hordist:5
CLASSMODELTYPE "Business process model"
CLASSPAR "Subsequent" space:1 turn:0 priority:1
CLASSPAR "Sets" space:1 turn:1 priority:1
CLASSPAR "Uses" space:1 turn:0 priority:1
CLASSPAR "Sets variable" space:1 turn:0 priority:1
CLASSPAR "Uses" space:1 turn:0 priority:1
CLASSMODELTYPE "Company map"
CLASSPAR "Has process" space:1 turn:0 priority:1
PROFILE "Hierarchy" type:"hier"
DEFMODELTYPE "Company map"
MINCROSS upon upcount:10 dwnon dwncount:10
PENDULUM upon upcount:10 dwnon dwncount:10
FLIPFLY dwn
DOUBLEBP dist:3
CHNGSIZE vertdist:5 hordist:4
CLASSMODELTYPE "Company map"
CLASSPAR "Has process" space:1 turn:0 priority:1
HIERPROFILE "BP-Hierarchy" use:"Hierarchy"
HIERMODELTYPE "Business process model" usetype:"Company map"
HIERATTRIB "Referenced subprocess"
HIERCLASS "Subprocess"
HIERUSECLASS "Process"
HIERUSEREL "Has process"
HIERUSEATTRIB "Referenced process"
ENUMPROFILE "Numbering"
ENUMMODELTYPE "Business process model"
ENUMREL "Subsequent"
ENUMCLASS "Activity" attrib:"Order" inflow
ENUMCLASS "Decision" attrib:"Order" inflow
ENUMCLASS "Parallelity" attrib:"Order" inflow
ENUMCLASS "Merging" attrib:"Order" inflow
ENUMCLASS "Subprocess" attrib:"Order" inflow
ENUMCLASS "Process start" attrib:"Order" inflow
ENUMCLASS "End" attrib:"Order" inflow
ENUMMODELTYPE "Company map"
ENUMREL "Has process" turn:0
ENUMCLASS "Process" attrib:"Order" inflow
ENUMMODELTYPE "Working environment model"
ENUMREL "Is subordinated" turn:0
ENUMCLASS "Organizational unit" attrib:"Order" inflow

```

ADONIS BPMS WE Library 3.9:

This attribute is not used in the ADONIS BPMS WE Library 3.9.

2.17 Relation analysis (Analysis)

ADONIS BPMS BP Library 3.9:

```
RELATIONTABLE "~Activity-Resource table"
modeltype:"Business process model"
fromclass:"Activity"
fromattribute:"Name"
toclass:"Resource"
toattribute:"Name"
relation:"Uses"
RELATIONTABLE "Activity--Document table"
modeltype:"Business process model"
fromclass:"Activity"
fromattribute:"Name"
tomodeltype:"Document model"
toclass:"Document"
toattribute:"Name"
FOREACHFROM
  EXPR " --> \"Referenced documents\""
RELATIONTABLE "Activity--Input document table"
modeltype:"Business process model"
fromclass:"Activity"
fromattribute:"Name"
tomodeltype:"Document model"
toclass:"Document"
toattribute:"Name"
FOREACHFROM
  EXPR " --> \"Input\""
RELATIONTABLE "Activity--Output document table"
modeltype:"Business process model"
fromclass:"Activity"
fromattribute:"Name"
tomodeltype:"Document model"
toclass:"Document"
toattribute:"Name"
FOREACHFROM
  EXPR " --> \"Output\""
RELATIONTABLE "~Variable-Activity table"
modeltype:"Business process model"
fromclass:"Variable"
fromattribute:"Name"
toclass:"Activity"
toattribute:"Name"
FOREACHFROM
  EXPR "<- \"Sets variable\" -> \"Sets\""
```

ADONIS BPMS WE Library 3.9:

```
RELATIONTABLE "~Role table"
fromclass:"Performer"
fromattribute:"Name"
toclass:"Role"
toattribute:"Name"
relation:"Has role"
RELATIONTABLE "~Organizational hierarchy table"
fromclass:"Organizational unit"
```

```

fromattribute:"Name"
toclass:"Organizational unit"
toattribute:"Name"
relation:"Is subordinated"

```

2.18 Simulation definition - Simtext (Simulation)

ADONIS BPMS BP Library 3.9:

```

SIMTEXT
bp: "Business process"
cycletime: "Cycle time"
activity: "Activity"
number: "Number"
actor: "Performer"
perscost: "Personnel costs"
resource: "Resource"
rescost: "Resource costs"

```

ADONIS BPMS WE Library 3.9:

This attribute is not used in the ADONIS BPMS WE Library 3.9.

2.19 Simulation definition - Simmapping (Simulation)

ADONIS BPMS BP Library 3.9:

```

SIMOPTION
name: "Standard"
name_de: "Default"
activity: "Activity"
helptext: "The standard input parameters contain the activity attributes 'Execution
time', 'Waiting time', 'Resting time', 'Transport time' and 'Costs'."
helptext_de: "Die standardmäßigen Eingabeparameter beinhalten die Aktivitätsattrib-
ute 'Bearbeitungszeit', 'Wartezeit', 'Liegezeit', 'Transportzeit' und 'Kosten'."
executiontime: "Execution time"
waitingtime: "Waiting time"
restingtime: "Resting time"
transporttime: "Transport time"
userattribute-1: "Costs"
processcall: "Subprocess" subperformerattr:"Performer"
SIMOPTION
name: "Without resting and transport time"
name_de: "Ohne Liege- und Transportzeit"
activity: "Activity"
helptext: "The activity attributes 'Resting time' and 'Transport time' are not con-
tained within this set of input parameters."
helptext_de: "Die Aktivitätsattribute 'Liegezeit' und 'Transportzeit' sind in
diesen Eingabeparametern nicht enthalten."
executiontime: "Execution time"
waitingtime: "Waiting time"
userattribute-1: "Costs"
processcall: "Subprocess" subperformerattr:"Performer"
SIMCLASSES
bp-1: "Activity"
bp-2: "Subprocess"
we-1: "Performer"

```

Part IV

we-2: "Resource"
we-3: "Organizational unit"
we-4: "Role"

ADONIS BPMS WE Library 3.9:

SIMOPTION undefined

2.20 Simulation definition - Sim result mapping (Simulation)

ADONIS BPMS BP Library 3.9:

```
PROCESSSTART "Process start"  
fixedinfo:"Info on results"  
fixedcycletime:"Aggregated cycle time"  
fixedpersonalcosts:"Aggregated personnel costs"  
FROMCLASS "Activity"  
fromattribute:"Costs"  
resultattribute:"Aggregated costs"  
FROMCLASS "Activity"  
fromattribute:"Execution time"  
resultattribute:"Aggregated execution time"  
FROMCLASS "Activity"  
fromattribute:"Waiting time"  
resultattribute:"Aggregated waiting time"  
FROMCLASS "Activity"  
fromattribute:"Transport time"  
resultattribute:"Aggregated transport time"  
FROMCLASS "Activity"  
fromattribute:"Resting time"  
resultattribute:"Aggregated resting time"  
ACTIVITY "Activity"  
fixedinfo:"Info on results"  
fixednumber:"Number"  
fixedpersonalcosts:"Aggregated personnel costs"  
FROMCLASS "Activity"  
fromattribute:"Execution time"  
resultattribute:"Aggregated execution time"  
FROMCLASS "Activity"  
fromattribute:"Waiting time"  
resultattribute:"Aggregated waiting time"  
FROMCLASS "Activity"  
fromattribute:"Transport time"  
resultattribute:"Aggregated transport time"  
FROMCLASS "Activity"  
fromattribute:"Resting time"  
resultattribute:"Aggregated resting time"  
FROMCLASS "Activity"  
fromattribute:"Costs"  
resultattribute:"Aggregated costs"
```

ADONIS BPMS WE Library 3.9:

```
PERSON "Performer"  
fixedinfo:"Info on results"  
fixedworkload:"Capacity"  
fixedcapacity:"Workload"  
fixedpersonalcosts:"Personnel costs"
```

2.21 Simulation definition - Variable check (Simulation)

ADONIS BPMS BP Library 3.9:

on

ADONIS BPMS WE Library 3.9:

on

2.22 Agent definition (Simulation)

ADONIS BPMS BP Library 3.9:

```

AGENT "Standard"
auto-buildsum
objects: "<\\"Activity\\"> OR <\\"Subprocess\\">"
allowed-modeltype-1: "Business process model"
infotext: "Computes the standard results of the simulation. The computation can be
limited to subprocesses or to part processes.Hint: The capacity will only be dis-
played \\"per <time period>\\" (eg \\"per year\\")."
FREQUENCY
name:"Frequency (relative)"
resultscope:allobjects
relative
ignore-not-executed-objects
AVGSUM
name:"Execution time"
lock-name
resultscope:allobjects
class:"Activity"
attribute:"Execution time"
attribute-type:time
lock-class
lock-attribute
AVGSUM
name:"Waiting time"
path-analysis
volume-analysis
resultscope:allobjects
class:"Activity"
attribute:"Waiting time"
attribute-type:time
lock-class
lock-attribute
AVGSUM
name:"Resting time"
lock-name
resultscope:allobjects
class:"Activity"
attribute:"Resting time"
attribute-type:time
lock-class
lock-attribute
AVGSUM
name:"Transport time"
lock-name
resultscope:allobjects

```

Part IV

```
class:"Activity"
attribute:"Transport time"
attribute-type:time
lock-class
lock-attribute
STRAIN
name:"Capacity"
resultscope:mainobjects
class:"Performer"
lock-class
WORKLOAD
name:"Workload"
resultscope:mainobjects
class:"Performer"
lock-class
WWECCOST
name:"Personnel costs"
resultscope:mainobjects
class:"Performer"
attribute:"Hourly wages"
lock-class
lock-attribute
UWWECCOST
name:"Personnel costs (conditional)"
wlstatic-analysis
wlnonstatic-analysis
resultscope:mainobjects
class:"Performer"
attribute:"Hourly wages"
lock-class
lock-attribute
WWECCOST
name:"Resource costs"
resultscope:mainobjects
class:"Resource"
attribute:"Hourly wages"
lock-class
lock-attribute
UWWECCOST
name:"Resource costs (conditional)"
wlstatic-analysis
wlnonstatic-analysis
resultscope:mainobjects
class:"Resource"
attribute:"Hourly wages"
lock-class
lock-attribute
AVGSUM
name:"Costs"
path-analysis
volume-analysis
wlstatic-analysis
wlnonstatic-analysis
resultscope:allobjects
class:"Activity"
attribute:"Costs"
attribute-type:numeric
lock-class
lock-attribute
CYCLETIME
name:"Cycle time"
```

```

lock-name
resultscope:allobjects
AGENT "Animation / Simulation progress"
objects: "<"Activity"> OR <"Subprocess">"
infotext: "This agent animates the cycletime while simulation progresses. You will
be able to determine when stable results are generated by the simulation."
objects: "<"Activity"> OR <"Subprocess">"
CYCLETIME
name:"Cycle time"
lock-name
resultscope:process
lock-resultscope
dont-show-result
ANIMATION
name:"Animation of the cycletime"
OBSERVED "Cycle time"
AGENT "Modeling check"
objects: "<"Activity">"
path-analysis
lock-calendar
auto-buildsum
hide-extremum
infotext:"This agent checks models for modelling errors during the path analysis:
it checks for all activities, that simulation attributes are greater than 0 and
that the activities are ever executed. (Note: This check occurs at the process
level as well to indicate whether the expected values of each attribute are greater
than 0 for the process.) The subprocesses are not checked according to the stan-
dards. - Note about the visualization of the results: Activites that are in never
executed process paths are marked with a '1' in the column 'Never executed'. Ac-
tivities that are not completely attributed are marked with a '1' in the column of
the corresponding attribute. "
lock-select-results
FORMULA
name:"FEHLER"
path-analysis
expression:"cond(("Frequency\" > 0) AND
(\"ET\" >0) AND (\"Costs\">0) AND (\"RT\" >0) AND
(\"TT\">0) AND (\"WT\">0), 0, 1)"
lock-expression
OBSERVED "Frequency"
OBSERVED "ET"
OBSERVED "Costs"
OBSERVED "RT"
OBSERVED "TT"
OBSERVED "WT"
FORMULA
name:"Never executed"
path-analysis
expression:"cond(\"Frequency\" > 0, 0, 1)"
lock-expression
OBSERVED "Frequency"
FORMULA
name:"ET missing"
path-analysis
expression:"N:cond(\"ET\"> 0, 0, 1)"
lock-expression
OBSERVED "ET"
FORMULA
name:"WT missing"
path-analysis
expression:"N:cond(\"WT\" > 0, 0, 1)"

```

Part IV

```
lock-expression
OBSERVED "WT"
FORMULA
name:"RT missing"
path-analysis
expression:"N:cond(\"RT\" > 0, 0, 1)"
lock-expression
OBSERVED "RT"
FORMULA
name:"TT missing"
path-analysis
expression:"N:cond(\"TT\" > 0, 0, 1)"
lock-expression
OBSERVED "TT"
FORMULA
name:"Costs missing"
path-analysis
expression:"cond(\"Costs\" > 0, 0, 1)"
lock-expression
OBSERVED "Costs"
FREQUENCY
name:"Frequency"
lock-name
hide-history-mem
hide-history-disk
dont-show-result
hide-show-result
path-analysis
hide-algorithms
resultscope:mainobjects
relative
hide-mode
hide-ignore
AVGSUM
name:"ET"
lock-name
hide-history-mem
hide-history-disk
dont-show-result
hide-show-result
path-analysis
hide-algorithms
resultscope:mainobjects
class:"Activity"
attribute:"Execution time"
attribute-type:time
hide-class
hide-attribute
AVGSUM
name:"WT"
lock-name
hide-history-mem
hide-history-disk
dont-show-result
path-analysis
resultscope:mainobjects
class:"Activity"
attribute:"Waiting time"
attribute-type:time
hide-algorithms
hide-show-result
```



```

hide-class
hide-attribute
AVGSUM
name:"RT"
lock-name
hide-history-mem
hide-history-disk
dont-show-result
path-analysis
resultscope:mainobjects
class:"Activity"
attribute:"Resting time"
attribute-type:time
hide-algorithms
hide-show-result
hide-class
hide-attribute
AVGSUM
name:"TT"
lock-name
hide-history-mem
hide-history-disk
dont-show-result
path-analysis
resultscope:mainobjects
class:"Activity"
attribute:"Transport time"
attribute-type:time
hide-algorithms
hide-show-result
hide-class
hide-attribute
AVGSUM
name:"Costs"
lock-name
hide-history-mem
hide-history-disk
dont-show-result
path-analysis
resultscope:mainobjects
class:"Activity"
attribute:"Costs"
attribute-type:numeric
hide-algorithms
hide-show-result
hide-class
hide-attribute
AGENT "BP agent: personnel"
objects: "<"Activity\ "> OR <"Subprocess\ ">"
volume-analysis
lock-calendar
allowed-modeltype-1: "Business process model"
infotext: "Results for persons from a BP view. This agent may only be used with the
capacity analysis.
The personnel requirements will be displayed \"per <time period>\" (eg \"per
year\")."
STRAIN
name:"Personnel requirements"
resultscope:mainobjects
class:"Performer"
lock-class

```

Part IV

```
WWECCOST
name:"Personnel costs"
resultscope:mainobjects
class:"Performer"
attribute:"Hourly wages"
lock-class
lock-attribute
RESPCHANGE
name:"Changes in responsibility"
resultscope:mainobjects
class:"Performer"
lock-class
AGENT "WE agent: personnel"
objects: "<"Performer">"
volume-analysis
lock-calendar
allowed-modeltype-1: "Working environment model"
infotext: "Results for persons from WE view. May only be used with the capacity
analysis.
The personnel requirements will be displayed \"per <time period>\" (eg \"per
year\")."
STRAIN
name:"Personnel requirements"
resultscope:mainobjects
class:"Performer"
lock-class
WWECCOST
name:"Personnel costs"
resultscope:mainobjects
class:"Performer"
attribute:"Hourly wages"
lock-class
lock-attribute
AGENT "BP Resource agent"
objects: "<"Activity"> OR <"Subprocess">"
volume-analysis
lock-calendar
allowed-modeltype-1: "Business process model"
infotext: "Results for resources from BP view. May only be used with the capacity
analysis.
The resource requirements will be displayed \"per <time period>\" (eg \"per
year\")."
STRAIN
name:"Resource requirements"
resultscope:mainobjects
class:"Resource"
lock-class
WWECCOST
name:"Resource costs"
resultscope:mainobjects
class:"Resource"
attribute:"Hourly wages"
lock-class
lock-attribute
RESPCHANGE
name:"Change in resources"
resultscope:mainobjects
class:"Resource"
lock-class
AGENT "Cycletime ratios"
objects: "<"Activity"> OR <"Subprocess">"
```

```

path-analysis
volume-analysis
lock-calendar
hide-buildsum
hide-group
lock-select-results
infotext:"Composition of the cycletime: Ratios of execution time, waiting time,
resting time and transport time. - Note: If parallelities are contained in a proc-
ess, ratios of more than 100% can be achieved."
AVGSUM
name:"Execution time"
lock-name
hide-history-mem
hide-history-disk
path-analysis
volume-analysis
wlstatic-analysis
wlnonstatic-analysis
resultscope:allobjects
dont-show-result
class:"Activity"
attribute:"Execution time"
attribute-type:time
lock-class
lock-attribute
AVGSUM
name:"Waiting time"
lock-name
hide-history-mem
hide-history-disk
path-analysis
volume-analysis
wlstatic-analysis
wlnonstatic-analysis
dont-show-result
resultscope:allobjects
class:"Activity"
attribute:"Waiting time"
attribute-type:time
lock-class
lock-attribute
AVGSUM
name:"Resting time"
lock-name
hide-history-mem
hide-history-disk
path-analysis
volume-analysis
wlstatic-analysis
wlnonstatic-analysis
resultscope:allobjects
dont-show-result
class:"Activity"
attribute:"Resting time"
attribute-type:time
lock-class
lock-attribute
AVGSUM
name:"Transport time"
lock-name
hide-history-mem

```

Part IV

```
hide-history-disk
path-analysis
volume-analysis
wlstatic-analysis
wlnonstatic-analysis
dont-show-result
resultscope:allobjects
class:"Activity"
attribute:"Transport time"
attribute-type:time
lock-class
lock-attribute
CYCLETIME
name:"Cycle time"
lock-name
hide-history-mem
hide-history-disk
path-analysis
volume-analysis
wlstatic-analysis
wlnonstatic-analysis
resultscope:allobjects
FORMULA
name:"% ratio ET"
hide-show-result
lock-show-result
hide-history-mem
hide-history-disk
dont-show-history
hide-show-history
path-analysis
volume-analysis
wlstatic-analysis
wlnonstatic-analysis
expression: "N: cond(\"Cycle time\" > 0, \"Execution time\" / \"Cycle time\" * 100,
0) "
lock-expression
OBSERVED "Execution time"
OBSERVED "Cycle time"
FORMULA
name:"% ratio WT"
hide-show-result
lock-show-result
hide-history-mem
hide-history-disk
dont-show-history
hide-show-history
path-analysis
volume-analysis
wlstatic-analysis
wlnonstatic-analysis
expression: "N: cond(\"Cycle time\" > 0, \"Waiting time\" / \"Cycle time\" * 100,
0) "
lock-expression
OBSERVED "Cycle time"
OBSERVED "Waiting time"
FORMULA
name:"% ratio RT"
hide-show-result
lock-show-result
hide-history-mem
```

```

hide-history-disk
dont-show-history
hide-show-history
path-analysis
volume-analysis
wlstatic-analysis
wlnonstatic-analysis
expression: "N: cond(\"Cycle time\" > 0, \"Resting time\" / \"Cycle time\" * 100,
0)"
lock-expression
OBSERVED "Resting time"
OBSERVED "Cycle time"
FORMULA
name:"% ratio TT"
hide-show-result
lock-show-result
hide-history-mem
hide-history-disk
dont-show-history
hide-show-history
path-analysis
volume-analysis
wlstatic-analysis
wlnonstatic-analysis
expression: "N: cond(\"Cycle time\" > 0, \"Transport time\" / \"Cycle time\" * 100,
0)"
lock-expression
OBSERVED "Transport time"
OBSERVED "Cycle time"

```

ADONIS BPMS WE Library 3.9:

This attribute is not used in the ADONIS BPMS WE Library 3.9.

2.23 Enterprise time - Days per year (Simulation)

ADONIS BPMS BP Library 3.9:

170,000000

ADONIS BPMS WE Library 3.9:

0,000000

2.24 Enterprise time - Hours per day (Simulation)

ADONIS BPMS BP Library 3.9:

8,000000

ADONIS BPMS WE Library 3.9:

0,000000

2.25 Activity based costing - CCC mapping (Evaluation)

ADONIS BPMS BP Library 3.9:

```
CCCLASS
costcenter: "Cost center"
relcount: "Is charged to"
relmanager: "Is cost center manager"
SYNONYMS
budget: "Budget"
lmntime: "ON time"
lmnproc: "ON processes"
lmnfix: "ON fixed costs"
ccmanager: "CC manager"
cccapp: "CC capacity"
lmiproc: "OI processes"
costdriver: "Cost driver"
cdquantity: "Cost driver quantity"
quantity: "Quantity"
idlecap: "Idle capacity"
executioncost: "Execution costs"
stuffcost: "Time dependent costs"
totalfixcost: "Total fixed costs"
lmncost: "ON costs"
idlecost: "Idle costs"
totalcost: "Total costs"
lmipcs: "OI-PCR"
pcs: "PCR"
```

ADONIS BPMS WE Library 3.9:

This attribute is not used in the ADONIS BPMS WE Library 3.9.

2.26 Activity based costing - CCC default settings (Evaluation)

2.27 Dynamic evaluation modules (Evaluation)

ADONIS BPMS BP Library 3.9:

This attribute is not used in the ADONIS BPMS BP Library 3.9.

ADONIS BPMS WE Library 3.9:

This attribute is not used in the ADONIS BPMS WE Library 3.9.

2.28 Configuration of documentation (Documentation)

ADONIS BPMS BP Library 3.9:

```
ATTRIBUTEMODI "@Documentation@@Doku@@Documentation with simulation data@@DokuSim@"
#@Cockpit@@Cockpit
EXPORT "WORD generation"
```

```

smarticon:rtf
visible:0
menuname: "WORD generation..."
filedescription: "WORD files"
fileextension: "*.doc"
filename:attribute: "filename"
templ: "tempfilename"
SOURCE "Model2SGML"
  filename:attribute: "tempfilename"
  basename:attribute: "filename"
  libraryspecific:attribute: "Apply model type specific settings"
  subprocesses:attribute: "Display subprocesses"
  acfilter:attribute: "Attribute and class filter"
LIBRARY
  gfxformat:attribute: "Graphic format for WORD"
  gfxdpi: 96.000000
  notebookattr:attribute: "Attribute mode"
  graphics:attribute: "Create graphics"
  gfxorientation:attribute: "Orientation"
  gfxlayout:attribute: "Page layout"
  mode:attribute: "Mode"
  gfxmode:attribute: "Graphic file mode"
LIBRARY "Company map"
  gfxformat:attribute: "Graphic format for WORD (CM)"
  gfxdpi: 96.000000
  notebookattr:attribute: "Attribute mode (CM)"
  graphics:attribute: "Create graphics (CM)"
  gfxorientation:attribute: "Orientation (CM)"
  gfxlayout:attribute: "Page layout (CM)"
  mode:attribute: "Mode (CM)"
  gfxmode:attribute: "Graphic file mode (CM)"
LIBRARY "Business process model"
  gfxformat:attribute: "Graphic format for WORD (BP)"
  gfxdpi: 96.000000
  notebookattr:attribute: "Attribute mode (BP)"
  graphics:attribute: "Create graphics (BP)"
  gfxorientation:attribute: "Orientation (BP)"
  gfxlayout:attribute: "Page layout (BP)"
  mode:attribute: "Mode (BP)"
  gfxmode:attribute: "Graphic file mode (BP)"
LIBRARY "Working environment model"
  gfxformat:attribute: "Graphic format for WORD (WE)"
  gfxdpi: 96.000000
  notebookattr:attribute: "Attribute mode (WE)"
  graphics:attribute: "Create graphics (WE)"
  gfxorientation:attribute: "Orientation (WE)"
  gfxlayout:attribute: "Page layout (WE)"
  mode:attribute: "Mode (WE)"
  gfxmode:attribute: "Graphic file mode (WE)"
LIBRARY "Document model"
  gfxformat:attribute: "Graphic format for WORD (DOC)"
  gfxdpi: 96.000000
  notebookattr:attribute: "Attribute mode (DOC)"
  graphics:attribute: "Create graphics (DOC)"
  gfxorientation:attribute: "Orientation (DOC)"
  gfxlayout:attribute: "Page layout (DOC)"
  mode:attribute: "Mode (DOC)"
  gfxmode:attribute: "Graphic file mode (DOC)"
LIBRARY "Use case diagram"
  gfxformat:attribute: "Graphic format for WORD (UC)"
  gfxdpi: 96.000000

```

Part IV

```
notebookattr:attribute: "Attribute mode (UC)"
graphics:attribute: "Create graphics (UC)"
gfxorientation:attribute: "Orientation (UC)"
gfxlayout:attribute: "Page layout (UC)"
mode:attribute: "Mode (UC)"
gfxmode:attribute: "Graphic file mode (UC)"
LIBRARY "Product model"
  gfxformat:attribute: "Graphic format for WORD (PM)"
  gfxdpi: 96.000000
  notebookattr:attribute: "Attribute mode (PM)"
  graphics:attribute: "Create graphics (PM)"
  gfxorientation:attribute: "Orientation (PM)"
  gfxlayout:attribute: "Page layout (PM)"
  gfxmode:attribute: "Graphic file mode (PM)"
  mode:attribute: "Mode (PM)"
LIBRARY "IT system model"
  gfxformat:attribute: "Graphic format for WORD (ITS)"
  gfxdpi: 96.000000
  notebookattr:attribute: "Attribute mode (ITS)"
  graphics:attribute: "Create graphics (ITS)"
  gfxorientation:attribute: "Orientation (ITS)"
  gfxlayout:attribute: "Page layout (ITS)"
  gfxmode:attribute: "Graphic file mode (ITS)"
  mode:attribute: "Mode (ITS)"
SOURCE "UserVariable"
  filename:attribute:"tempfilename"
  var1:attribute:"Language"
SOURCE "AdoScript"
  name: "Jade Converter"
  var1:attribute: "tempfilename"
  var2:attribute: "filename"
  var3:attribute: "homedir"
{
  SETG filename:(filename)
  SETG homedir:(homedir)
  SETG tempfilename:(tempfilename)
  SET nPos:(bsearch (filename , "\\\" , -1))
  #when char is found save path and file name into different vars
  IF (nPos > 0)
  {
    SET dest_path:(copy (filename, 0, nPos))
    SET file_name:(copy (filename, nPos, LEN (filename) - 1))
  }
  ELSE
  {
    SET dest_path:(filename)
    SET file_name:(filename)
  }
  CC "AdoScript" FCOPY from:(tempfilename) to:(dest_path + "\\out0.sgm")
}
EXPORT "HTML generation"
  smarticon:html
  visible:0
  menuname: "HTML generation..."
  filedescription: "HTML files"
  fileextension: "*.htm"
  filename:attribute: "filename"
  temp1: "tempfilename"
  SOURCE "Model2SGML"
    filename:attribute: "tempfilename"
    basename:attribute: "filename"
```



```

libraryspecific:attribute: "Apply model type specific settings"
subprocesses:attribute: "Display subprocesses"
acfilter:attribute: "Attribute and class filter"
copydocuments:attribute: "__DOCU_copydocs__"
LIBRARY
  gfxformat: "png"
  gfxdpi: 75.000000
  notebookattr:attribute: "Attribute mode"
  graphics:1
  gfxorientation:"do not change"
  gfxlayout:"do not split graphic files"
  gfxmode: "Documentation"
  mode:attribute: "Mode"
  gfxdozoom:1
  gfxzoomlevels:attribute:"__DOCU_zoomlevels__"
SOURCE "ModelGroups"
  filename:attribute:"tempfilename"
  exportall:0
SOURCE "UserVariable"
  filename:attribute:"tempfilename"
  var1:attribute:"Language"
  var2:attribute:"str_TopModelID"
SOURCE "AdoScript"
  name: "Jade Converter"
  var1:attribute: "tempfilename"
  var2:attribute: "filename"
  var3:attribute: "homedir"
{
  SETG filename:(filename)
  SETG homedir:(homedir)
  SETG tempfilename:(tempfilename)
  SET nPos:(bsearch (filename , "\\", -1))
  #when char is found save path and file name into different vars
  IF (nPos > 0)
  {
    SET dest_path:(copy (filename, 0, nPos))
    SET file_name:(copy (filename, nPos, LEN (filename) - 1))
  }
  ELSE
  {
    SET dest_path:(filename)
    SET file_name:(filename)
  }
}
  CC "AdoScript" FCOPY from:(tempfilename) to:(dest_path + "\\out0.sgm")
}
DIALOG
notebook:"NOTEBOOK"
CHAPTER \"General Settings\"
ATTR \"Apply model type specific settings\" ctrltype:check
GROUP \"Attribute settings\"
ATTR \"Language\" ctrltype:dropdown
ATTR \"Mode\" ctrltype:dropdown
ATTR \"Attribute mode\" ctrltype:dropdown
ATTR \"Attribute and class filter\" dialog:acfilter
ENDGROUP
GROUP \"Settings for WORD\"
ATTR \"Create graphics\" ctrltype:check
ATTR \"Graphic file mode\" ctrltype:dropdown
ATTR \"Graphic format for WORD\" ctrltype:dropdown
ATTR \"Page layout\" ctrltype:dropdown
ATTR \"Orientation\" ctrltype:dropdown

```

Part IV

```
ENDGROUP
GROUP \"Settings for HTML\"
ATTR \"Copy referenced documents\" ctrltype:check unchecked-value:\"\" checked-
value:\"documents\\\\\\\\\\\\\\\\\"
ATTR \"Zoom frame\" ctrltype:check unchecked-value:\"no\" checked-value:\"yes\"
ENDGROUP
ATTR \"Show preferences before the generation\" ctrltype:check unchecked-
value:\"no\" checked-value:\"yes\"
CHAPTER \"Product model\"
GROUP \"Options for WORD (Product models)\"
ATTR \"Mode (PM)\" ctrltype:dropdown
ATTR \"Attribute mode (PM)\" ctrltype:dropdown
ATTR \"Create graphics (PM)\" ctrltype:check
ATTR \"Graphic file mode (PM)\" ctrltype:dropdown
ATTR \"Graphic format for WORD (PM)\" ctrltype:dropdown
ATTR \"Page layout (PM)\" ctrltype:dropdown
ATTR \"Orientation (PM)\" ctrltype:dropdown
ENDGROUP
CHAPTER \"Company map\"
GROUP \"Attribute settings for WORD (Company maps)\"
ATTR \"Mode (CM)\" ctrltype:dropdown
ATTR \"Attribute mode (CM)\" ctrltype:dropdown
ATTR \"Create graphics (CM)\" ctrltype:check
ATTR \"Graphic file mode (CM)\" ctrltype:dropdown
ATTR \"Graphic format for WORD (CM)\" ctrltype:dropdown
ATTR \"Page layout (CM)\" ctrltype:dropdown
ATTR \"Orientation (CM)\" ctrltype:dropdown
ENDGROUP
CHAPTER \"Business process model\"
GROUP \"Settings for WORD in business process models\"
ATTR \"Mode (BP)\" ctrltype:dropdown
ATTR \"Attribute mode (BP)\" ctrltype:dropdown
ATTR \"Create graphics (BP)\" ctrltype:check
ATTR \"Graphic file mode (BP)\" ctrltype:dropdown
ATTR \"Graphic format for WORD (BP)\" ctrltype:dropdown
ATTR \"Page layout (BP)\" ctrltype:dropdown
ATTR \"Orientation (BP)\" ctrltype:dropdown
ENDGROUP
CHAPTER \"Working environment model\"
GROUP \"Settings for WORD (Working environment models)\"
ATTR \"Mode (WE)\" ctrltype:dropdown
ATTR \"Attribute mode (WE)\" ctrltype:dropdown
ATTR \"Create graphics (WE)\" ctrltype:check
ATTR \"Graphic file mode (WE)\" ctrltype:dropdown
ATTR \"Graphic format for WORD (WE)\" ctrltype:dropdown
ATTR \"Page layout (WE)\" ctrltype:dropdown
ATTR \"Orientation (WE)\" ctrltype:dropdown
ENDGROUP
CHAPTER \"Document model\"
GROUP \"Settings for WORD (Document models)\"
ATTR \"Mode (DOC)\" ctrltype:dropdown
ATTR \"Attribute mode (DOC)\" ctrltype:dropdown
ATTR \"Create graphics (DOC)\" ctrltype:check
ATTR \"Graphic file mode (DOC)\" ctrltype:dropdown
ATTR \"Graphic format for WORD (DOC)\" ctrltype:dropdown
ATTR \"Page layout (DOC)\" ctrltype:dropdown
ATTR \"Orientation (DOC)\" ctrltype:dropdown
ENDGROUP
CHAPTER \"IT System model\"
GROUP \"Settings for WORD (IT System model)\"
ATTR \"Mode (ITS)\" ctrltype:dropdown
```

```
ATTR \"Attribute mode (ITS)\" ctrltype:dropdown
ATTR \"Create graphics (ITS)\" ctrltype:check
ATTR \"Graphic file mode (ITS)\" ctrltype:dropdown
ATTR \"Graphic format for WORD (ITS)\" ctrltype:dropdown
ATTR \"Page layout (ITS)\" ctrltype:dropdown
ATTR \"Orientation (ITS)\" ctrltype:dropdown
ENDGROUP
CHAPTER \"Use case diagram\"
GROUP \"Settings for WORD (Use case diagram)\"
ATTR \"Mode (UC)\" ctrltype:dropdown
ATTR \"Attribute mode (UC)\" ctrltype:dropdown
ATTR \"Create graphics (UC)\" ctrltype:check
ATTR \"Graphic file mode (UC)\" ctrltype:dropdown
ATTR \"Graphic format for WORD (UC)\" ctrltype:dropdown
ATTR \"Page layout (UC)\" ctrltype:dropdown
ATTR \"Orientation (UC)\" ctrltype:dropdown
ENDGROUP
"
```

ADONIS BPMS WE Library 3.9:

This attribute is not used in the ADONIS BPMS WE Library 3.9.

Part V

Index

A

- Acquisition component 216
 - HOMER scenarios 216
- Activation of automatic random generator 236
- Activation of manual random generator 235
- Activity 57
- actor 35
- ADONIS 7
 - Hint 9
- ADONIS BPMS method 13
 - Business process model 20
 - Class attributes 284
 - Classes 35
 - Company map 18
 - Document model 29
 - IT system model 24
 - Library attributes 515
 - Model types 16
 - Product model 17
 - Relation classes 172
 - Use case diagram 27
 - Working environment model 30
- ADONIS Example models 255
- ADONIS manuals 3
- Aggregation 113, 162
- Allowed objects 513
- Analysis component 199
- Application 130
- Attribute and class filter 247
- Attribute profiles 252
- AttrRep 404

B

- Belongs to 195
- Business process model 20

C

- Calculate current values 238
- Cardinality 219
- Change modelling direction 231
- Class "Activity" 298, 411, 467, 513
- Class "actor" 286, 406, 454
- Class "Aggregation" 323, 371, 425, 440, 495
- Class "Application" 351, 430, 452, 503
- Class "Cost center" 370, 439, 512
- Class "Cross-reference" 358, 433, 452
- Class "Decision" 304, 415, 469
- Class "Document" 319, 424, 452, 490
- Class "End" 307, 417, 475
- Class "External partner" 346, 428, 497
- Class "Infrastructure element" 357, 433, 452, 509

- Class "Merging" 306, 417, 473
- Class "Note" 321, 373, 425, 441, 493
- Class "Organizational unit" 360, 434, 453
- Class "Parallelity" 305, 416, 471
- Class "Performance indicator overview" 315, 421, 486
- Class "Performance indicator" 316, 422, 488
- Class "Performance" 355, 432, 452, 507
- Class "Performer" 365, 436
- Class "Position" 367, 438
- Class "Process start" 292, 408, 462
- Class "Process" 313, 420, 451, 484
- Class "Product component" 350, 429, 452, 501
- Class "Product" 348, 428, 452, 499
- Class "Random generator" 309, 418, 480
- Class "Resource" 310, 368, 419, 438, 482
- Class "Role" 366, 437
- Class "Service" 353, 431, 452, 505
- Class "Subprocess" 296, 410, 451, 464, 512
- Class "Swimlane (horizontal)" 326, 375, 426, 441, 514
- Class "Swimlane (vertical)" 336, 383, 427, 442, 514
- Class "system boundary" 288, 407, 458
- Class "Trigger" 288, 408, 460
- Class "use case" 287, 406, 451, 456
- Class "Variable" 308, 418, 478
- Class attributes 284
 - Allowed objects 513
 - AttrRep 404
 - Class cardinality 453
 - Conversion 512
 - GraphRep 284
 - Model pointer 451
- Class cardinality 453
- Classes 35
 - Activity 57
 - actor 35
 - Aggregation 113, 162
 - Application 130
 - Cost center 160
 - Cross-reference 144
 - Decision 73
 - Document 107
 - End 79
 - External partner 122
 - Infrastructure element 140
 - Merging 77
 - Note 109, 164
 - Organizational unit 145
 - Parallelity 75
 - Performance 137
 - Performance indicator 98
 - Performance indicator overview 96
 - Performer 151
 - Position 156

Part V

- Process 90
- Process start 44
- Product 123
- Product component 127
- Random generator 84
- Resource 87, 158
- Role 155
- Service 134
- Subprocess 51
- Swimlane (horizontal) 116, 167
- Swimlane (vertical) 119, 169
- system boundary 39
- Trigger 41
- use case 37
- Variable 82
- communicates 178
- Company map 18
- Configure reference overview 231
- contains 181
- Conversion 512
- Copy model tree 219
- Corporate Identity (CI) 249
- Cost center 160
- Cross-reference 144

D

- Decision 73
- Display attributes in English 225
 - Implementation 228
 - Requirements 226
 - Translation of model names 227
- Display attributes in German 225
 - Implementation 228
 - Requirements 226
 - Translation of model names 227
- Display incorrect transition probability 230
- Document 107
- Document model 29

E

- End 79
- Evaluation component 211
- Example models 255
- Example-General.adl 255
- Example-General_with_resources.adl 262
- Expressions 250
- extends 182
- External partner 122

G

- Generalisation 180
- GraphRep 284

H

- has 188
- has 186
- has Cross-reference 193
- has Note 193, 198
- has position 195
- Has process 185

- has Resource 194
- Has role 196
- has Subdocument 186
- Hide reference overview 231
- Hide responsible roles 230
- Hierarchical model copy 219
- HOMER scenarios 216
- HTML generation 238

I

- Infrastructure element 140
- Initialise current values 237
 - Requirements 237
- Inter-model references (multiple models) 220
- Is charged to 197
- Is cost center manager 198
- Is dependent on 191
- Is manager 196
- Is subordinated 194
- IT system model 24

L

- Library attributes 515
 - Agent definition 539
 - Author 517
 - CCC default settings (Activity based costing) 548
 - CCC mapping (Activity based costing) 548
 - Comment 516
 - Configuration of documentation 548
 - Creation date 517
 - Date last changed 517
 - Days per year (Enterprise time) 547
 - Default settings 533
 - Description 516
 - Dynamic evaluation modules 548
 - External coupling 523
 - Graphical representation (Connector marks) 534
 - Hours per day (Enterprise time) 547
 - Keywords 516
 - Last user 517
 - Modi 517
 - Numbering (Connector marks) 534
 - Object arrangement 534
 - Page layouts 534
 - Relation analysis 536
 - Service 516
 - Sim result mapping (Simulation definition) 538
 - Simmapping (Simulation definition) 537
 - Simtext (Simulation definition) 537
 - Variable check (Simulation definition) 539
 - Versioning format 523
- Library specific functions 216
 - Acquisition 216
 - Activation of automatic random generator 236
 - Activation of manual random generator 235
 - Analysis 199
 - Attribute and class filter 247
 - Calculate current values 237, 238
 - Cardinality 219
 - Change modelling direction 231
 - Configure reference overview 231
 - Copy model tree 219
 - Corporate Identity (CI) HTML generation 249

Display attributes in English 225
 Display attributes in German 225
 Display incorrect transition probability 230
 Evaluation 211, 237
 Hide reference overview 231
 Hide responsible roles 230
 Hierarchical model copy 219
 HTML generation 238
 Import/Export 238
 Model view in grayscale 230
 Modelling 218
 Monitoring 237
 Monochrome view 230
 Number objects 222
 Object conversion 224
 Options (Documentation) 242
 Page layout 232
 Process Stepper 232
 Reset object numbering 224
 Show reference overview 231
 Show responsible roles 230
 Simulation 235
 Word generation 240

M

Merging 77
 Model pointer 451
 Model types 16
 Model view in grayscale 230
 Modelling component 218
 Monitoring 237
 Monochrome view 230

N

Note 109, 164
 Number objects 222

O

Object conversion 224
 Options (Documentation) 242
 Organizational unit 145
 Owns 192

P

Page layout 232
 Parallellity 75
 Performance 137
 Performance indicator 98
 Performance indicator overview 96
 Performer 151
 Position 156
 Predefined queries 199

- Activity-oriented queries on Business Process Models 213
- Consistency checks on Business Process Models 200
- Evaluation of the open questions in Business Process Models 203
- Evaluation of the open questions in company maps 199

Evaluation of the open questions in Use Case diagrams 206
 Predefined queries on Business Process Models 202
 Predefined queries on Working Environment models 204
 Process-oriented queries on Business Process Models 211
 Queries on Working Environment models 214
 Predefined relation tables 199

- Activity-Document table 208
- Activity-Input document table 208
- Activity-Output document table 209
- Activity-Resource table 207
- Organisational hierarchy table 210
- Role table 210
- Variable-Activity table 209

 Process 90
 Process start 44
 Process Stepper 232

- Additional functions 234
- Play back process animation 234
- Play back speed 234
- Process animation 233
- Remove marking of objects 234
- Turning execution time on/off 234

 Product 123
 Product component 127
 Product model 17

R

Random generator 84
 Relation class "Belongs to" 402
 Relation class "Call parameter" 393, 444
 Relation class "communicates" 393, 444
 Relation class "contains" 395, 446
 Relation class "extends" 396, 446
 Relation class "Generalisation" 395, 445
 Relation class "has " 398, 448
 Relation class "has Cross-reference" 401
 Relation class "has Note" 401, 404
 Relation class "has position" 402
 Relation class "Has process" 397, 448
 Relation class "has Resource" 402
 Relation class "Has role" 403
 Relation class "has Subdocument" 398
 Relation class "has" 399, 449
 Relation class "Is charged to" 403
 Relation class "Is cost center manager" 403
 Relation class "Is dependent on" 400, 450
 Relation class "Is manager" 402
 Relation class "Is subordinated" 401, 450
 Relation class "Owns" 401
 Relation class "Parameter" 393, 444
 Relation class "Sets variable" 392
 Relation class "Sets" 392
 Relation class "Subsequent" 391, 443
 Relation class "uses " 399, 449
 Relation class "Uses resource" 403
 Relation class "uses" 396, 447
 Relation class "Uses" 393
 Relation class "Value flow" 394, 445
 Relation classes 172

- Belongs to" 195

Part V

communicates" 178
contains" 181
extends" 182
Generalisation" 180
has " 186
has Cross-reference" 193
has Note" 193, 198
has position" 195
Has process" 185
has Resource" 194
Has role" 196
has Subdocument" 186
has" 188
Is charged to" 197
Is cost center manager" 198
Is dependent on" 191
Is manager" 196
Is subordinated" 194
Owns" 192
Sets variable" 176
Sets" 177
Subsequent" 172
uses " 189
Uses resource" 197
uses" 184
Uses" 177
Value flow" 179
Reset object numbering 224
Resource 87, 158
Role 155

S

Service 134
Sets 177

Sets variable 176
Show reference overview 231
Show responsible roles 230
Subprocess 51
Subsequent 172
Swimlane (horizontal) 116, 167
Swimlane (vertical) 119, 169
system boundary 39

T

Tables 254
Trademarks 10
Trigger 41

U

use case 37
Use case diagram 27
uses 184
uses 189
Uses 177
Uses resource 197

V

Value flow 179
Variable 82

W

Word generation 240
Working environment model 30

