

CS:APP Chapter 4

Computer Architecture

Wrap-Up

Randal E. Bryant

Carnegie Mellon University

<http://csapp.cs.cmu.edu>

Overview

Wrap-Up of PIPE Design

- Performance analysis
- Fetch stage design
- Exceptional conditions

Modern High-Performance Processors

- Out-of-order execution

Performance Metrics

Clock rate

- Measured in Megahertz or Gigahertz
- Function of stage partitioning and circuit design
 - Keep amount of work per stage small

Rate at which instructions executed

- CPI: cycles per instruction
- On average, how many clock cycles does each instruction require?
- Function of pipeline design and benchmark programs
 - E.g., how frequently are branches mispredicted?

CPI for PIPE

CPI \approx 1.0

- Fetch instruction each clock cycle
- Effectively process new instruction almost every cycle
 - Although each individual instruction has latency of 5 cycles

CPI $>$ 1.0

- Sometimes must stall or cancel branches

Computing CPI

- C clock cycles
- I instructions executed to completion
- B bubbles injected ($C = I + B$)

$$\text{CPI} = C/I = (I+B)/I = 1.0 + B/I$$

- Factor B/I represents average penalty due to bubbles

CPI for PIPE (Cont.)

$$B/I = LP + MP + RP$$

- | | Typical Values |
|---|----------------|
| ■ LP: Penalty due to load/use hazard stalling | |
| ● Fraction of instructions that are loads | 0.25 |
| ● Fraction of load instructions requiring stall | 0.20 |
| ● Number of bubbles injected each time | 1 |
| ⇒ $LP = 0.25 * 0.20 * 1 = 0.05$ | |
| ■ MP: Penalty due to mispredicted branches | |
| ● Fraction of instructions that are cond. jumps | 0.20 |
| ● Fraction of cond. jumps mispredicted | 0.40 |
| ● Number of bubbles injected each time | 2 |
| ⇒ $MP = 0.20 * 0.40 * 2 = 0.16$ | |
| ■ RP: Penalty due to <code>ret</code> instructions | |
| ● Fraction of instructions that are returns | 0.02 |
| ● Number of bubbles injected each time | 3 |
| ⇒ $RP = 0.02 * 3 = 0.06$ | |
| ■ Net effect of penalties $0.05 + 0.16 + 0.06 = 0.27$ | |
| ⇒ $CPI = 1.27$ (Not bad!) | |

Fetch Logic Revisited

During Fetch Cycle

- 1. Select PC
- 2. Read bytes from instruction memory
- 3. Examine icode to determine instruction length
- 4. Increment PC

Timing

- Steps 2 & 4 require significant amount of time

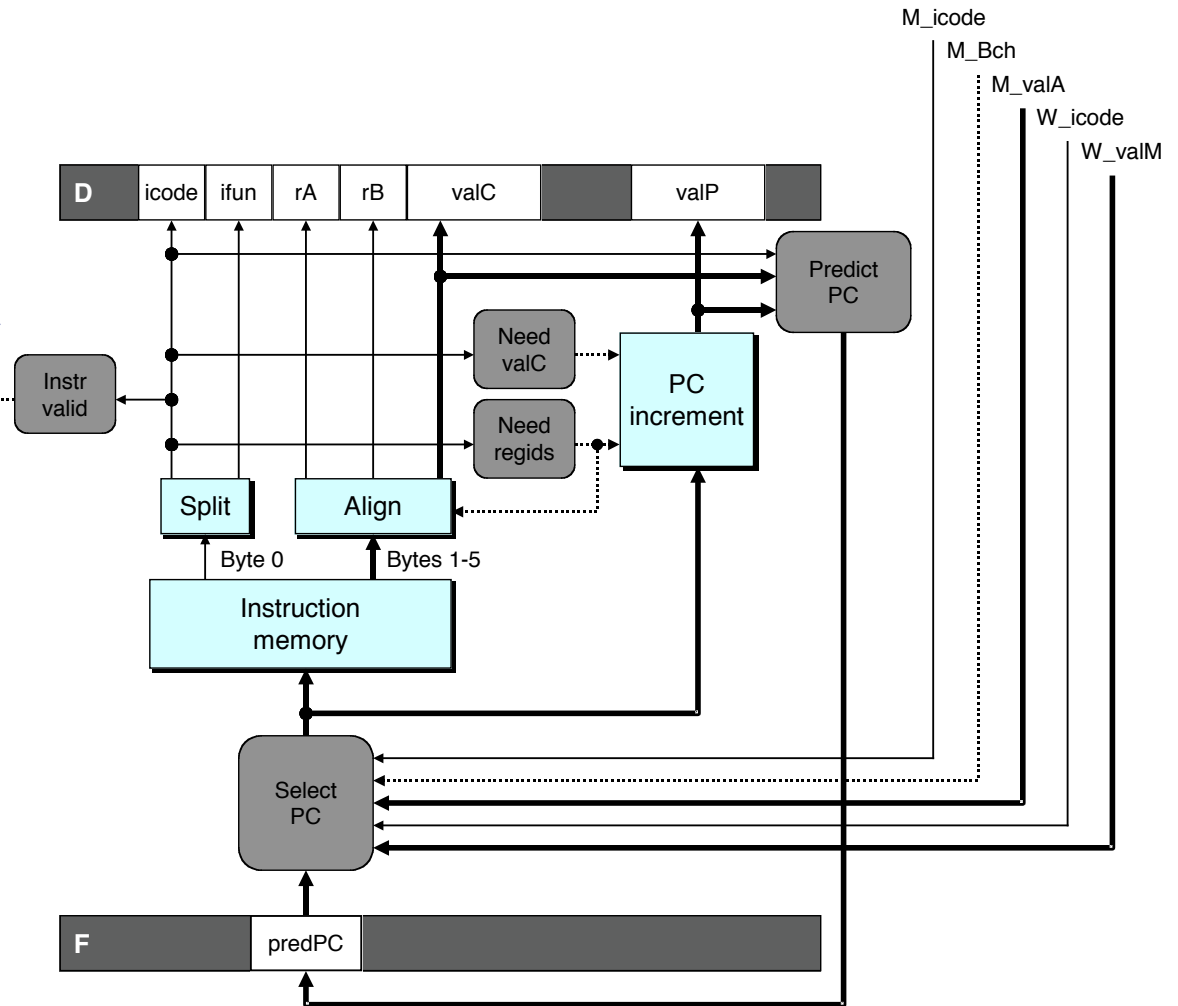

Standard Fetch Timing

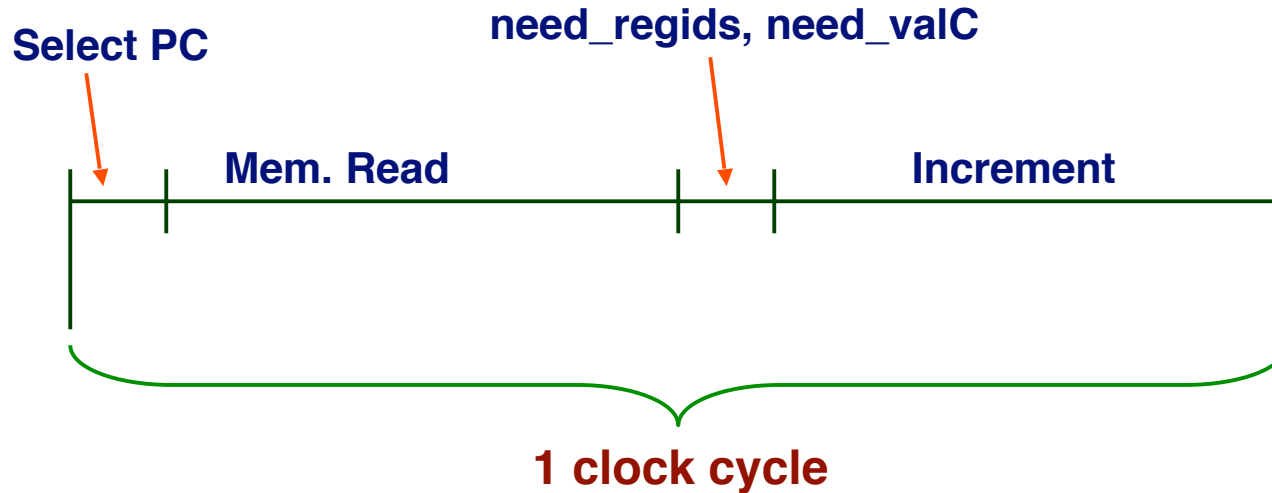

- **Must Perform Everything in Sequence**
- **Can't compute incremented PC until know how much to increment it by**

A Fast PC Increment Circuit

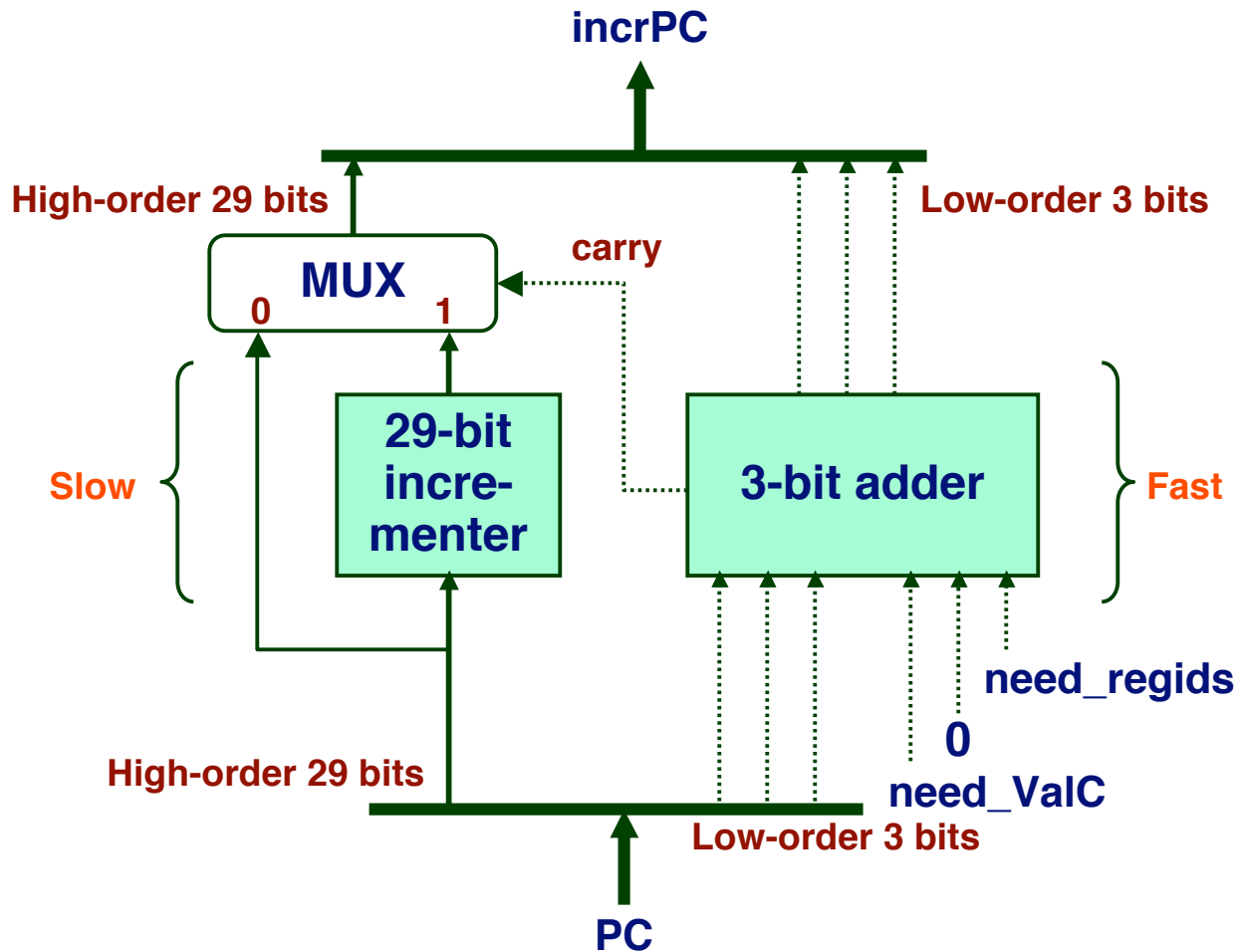

Modified Fetch Timing

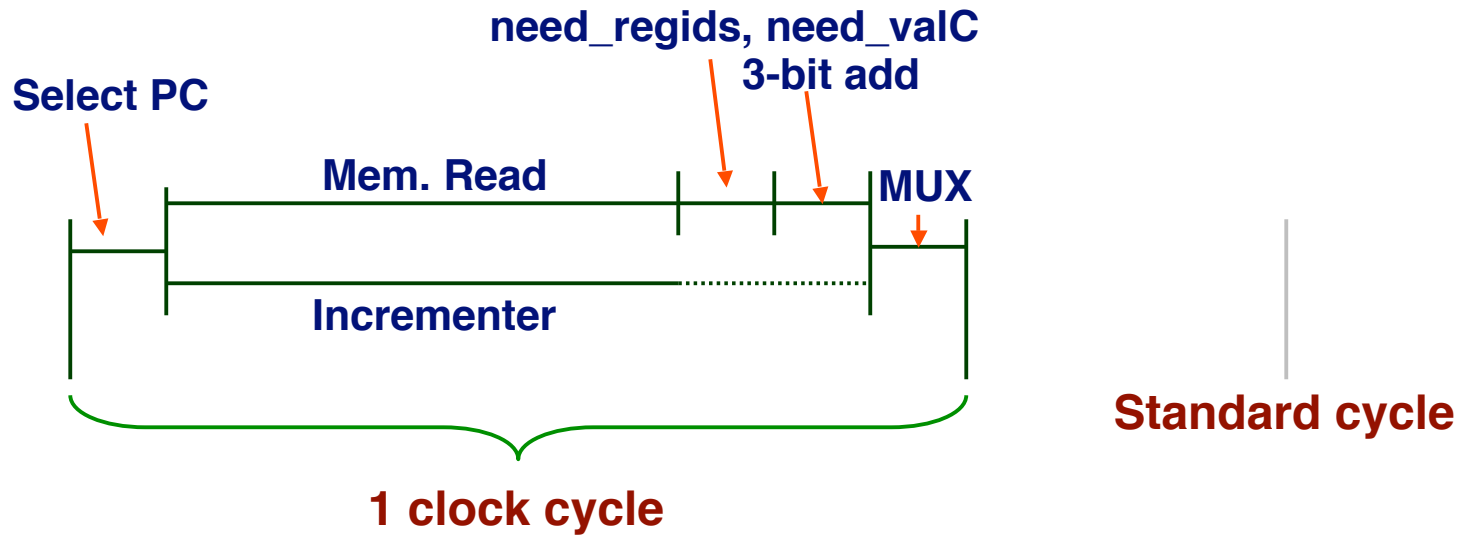

29-Bit Incrementer

- Acts as soon as PC selected
- Output not needed until final MUX
- Works in parallel with memory read

More Realistic Fetch Logic

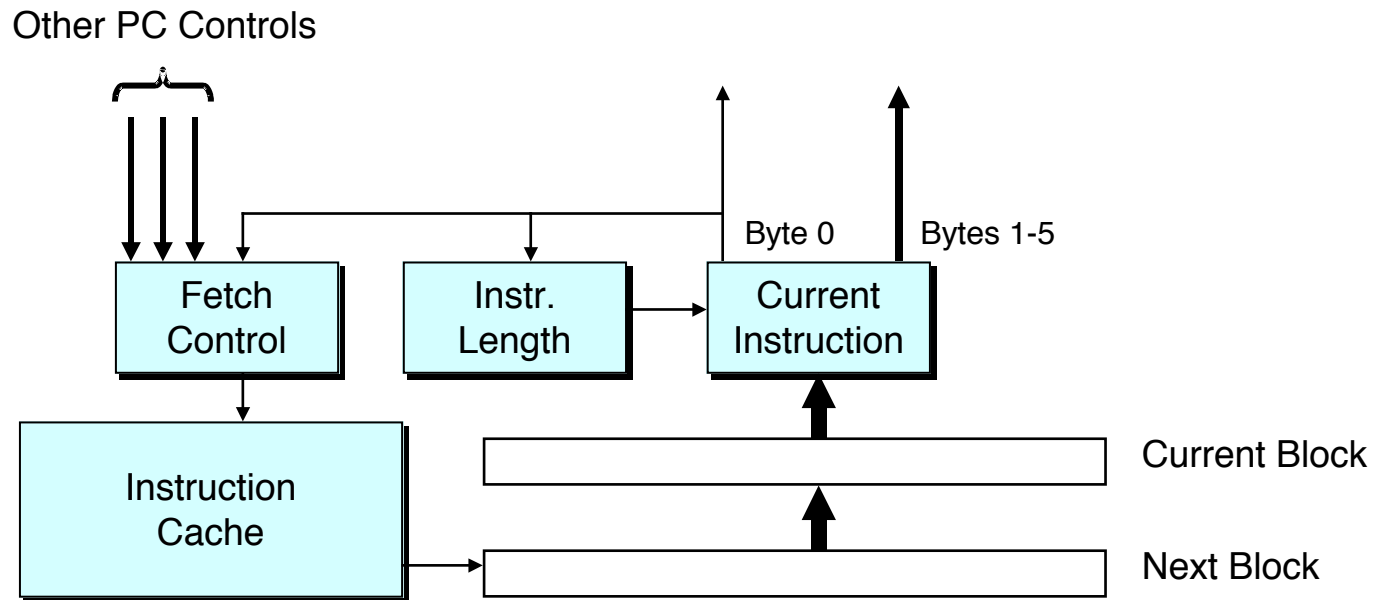

Fetch Box

- Integrated into instruction cache
- Fetches entire cache block (16 or 32 bytes)
- Selects current instruction from current block
- Works ahead to fetch next block
 - As reaches end of current block
 - At branch target

Exceptions

- Conditions under which pipeline cannot continue normal operation

Causes

- Halt instruction (Current)
- Bad address for instruction or data (Previous)
- Invalid instruction (Previous)
- Pipeline control error (Previous)

Desired Action

- Complete some instructions
 - Either current or previous (depends on exception type)
- Discard others
- Call exception handler
 - Like an unexpected procedure call



Exception Examples

Detect in Fetch Stage

```
jmp $-1                # Invalid jump target

.byte 0xFF             # Invalid instruction code

halt                   # Halt instruction
```

Detect in Memory Stage

```
irmovl $100,%eax
rmmovl %eax,0x10000(%eax) # invalid address
```

Exceptions in Pipeline Processor #1

```
# demo-excl1.y  
irmovl $100,%eax  
rmmovl %eax,0x10000(%eax) # Invalid address  
nop  
.byte 0xFF # Invalid instruction code
```

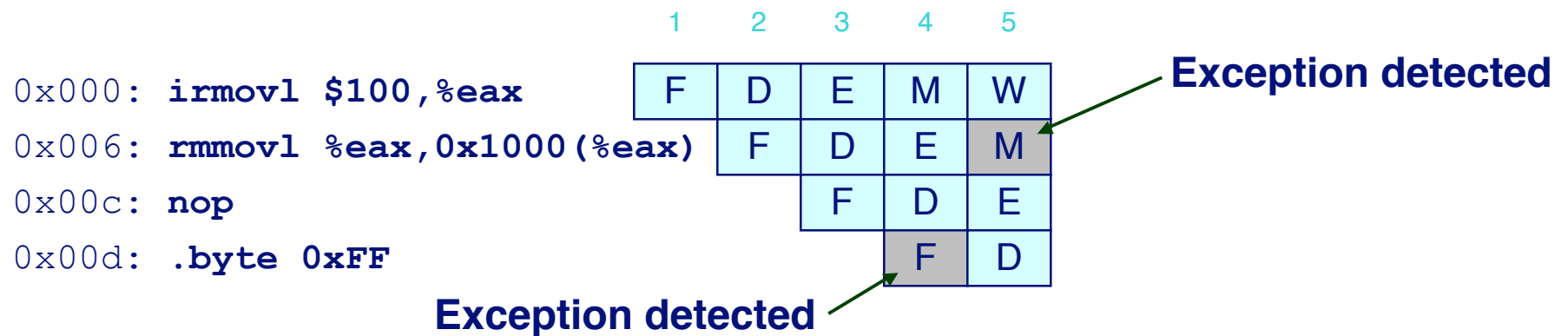

Desired Behavior

- `rmmovl` should cause exception

Exceptions in Pipeline Processor #2

```
# demo-exc2.y
0x000:    xorl %eax,%eax    # Set condition codes
0x002:    jne t            # Not taken
0x007:    irmovl $1,%eax
0x00d:    irmovl $2,%edx
0x013:    halt
0x014:    t: .byte 0xFF    # Target
```

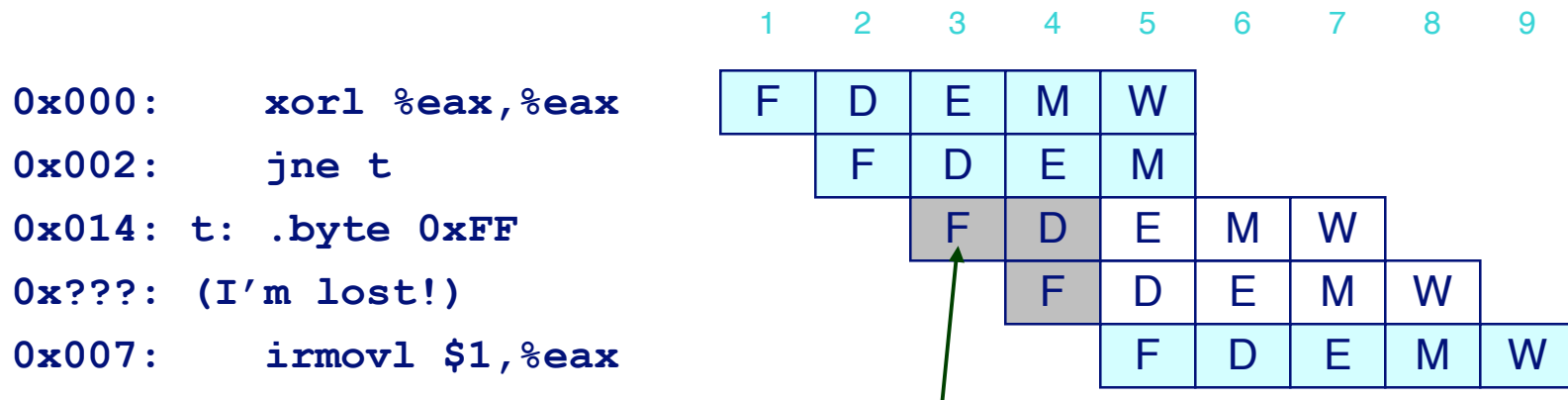

Exception detected

Desired Behavior

- No exception should occur

Maintaining Exception Ordering

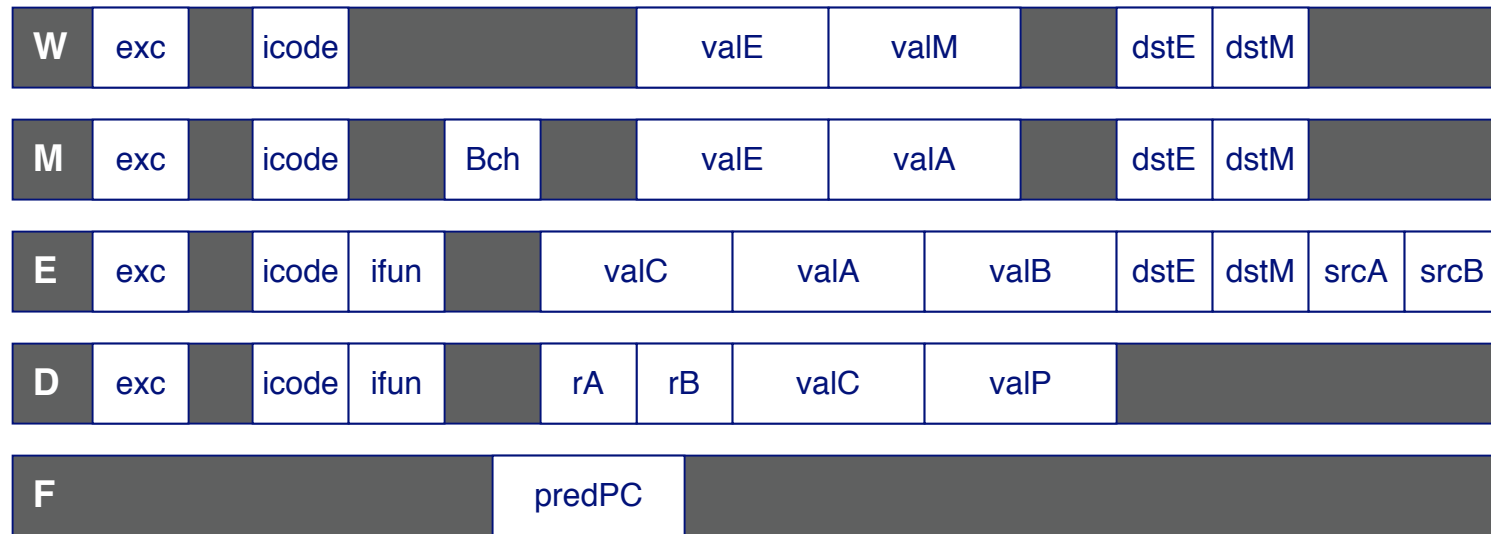

- Add exception status field to pipeline registers
- Fetch stage sets to either “AOK,” “ADR” (when bad fetch address), or “INS” (illegal instruction)
- Decode & execute pass values through
- Memory either passes through or sets to “ADR”
- Exception triggered only when instruction hits write back

Side Effects in Pipeline Processor

```
# demo-exc3.y  
irmovl $100,%eax  
rmmovl %eax,0x10000(%eax) # invalid address  
addl %eax,%eax           # Sets condition codes
```

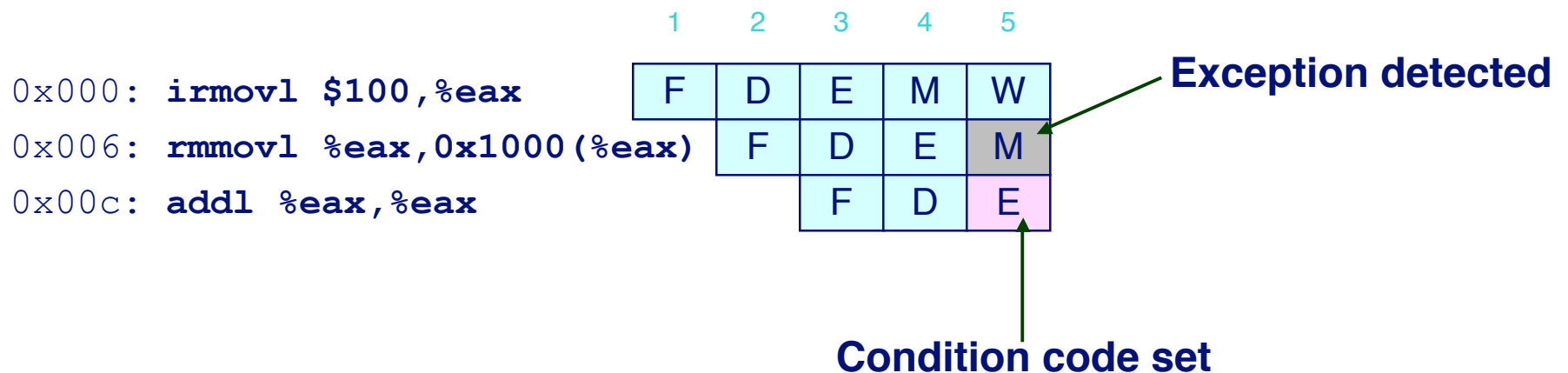

Desired Behavior

- `rmmovl` should cause exception
- No following instruction should have any effect

Avoiding Side Effects

Presence of Exception Should Disable State Update

- When detect exception in memory stage
 - Disable condition code setting in execute
 - Must happen in same clock cycle
- When exception passes to write-back stage
 - Disable memory write in memory stage
 - Disable condition code setting in execute stage

Implementation

- Hardwired into the design of the PIPE simulator
- You have no control over this

Rest of Exception Handling

Calling Exception Handler

- **Push PC onto stack**
 - Either PC of faulting instruction or of next instruction
 - Usually pass through pipeline along with exception status
- **Jump to handler address**
 - Usually fixed address
 - Defined as part of ISA

Implementation

- Haven't tried it yet!

Modern CPU Design

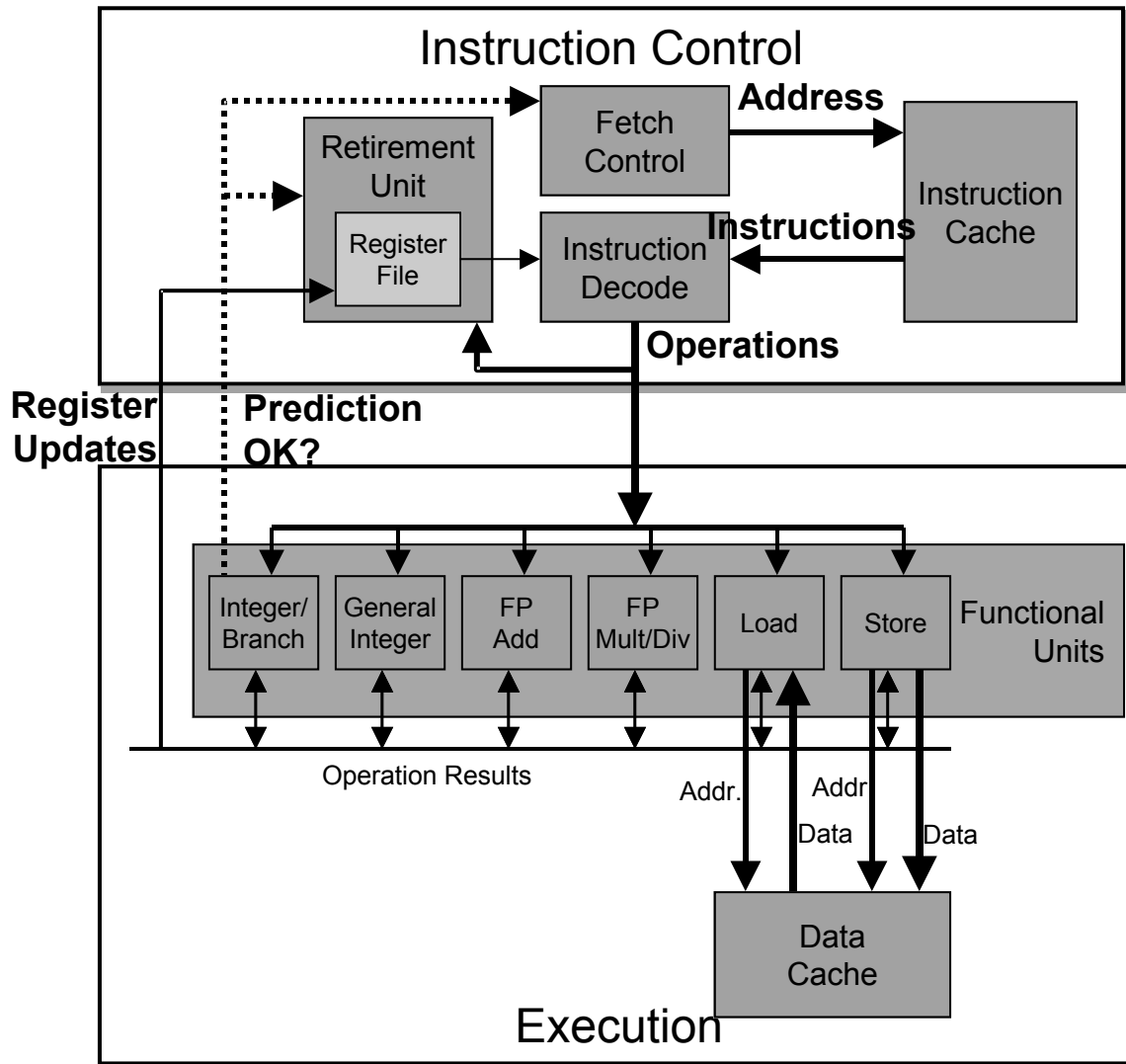

Instruction Control

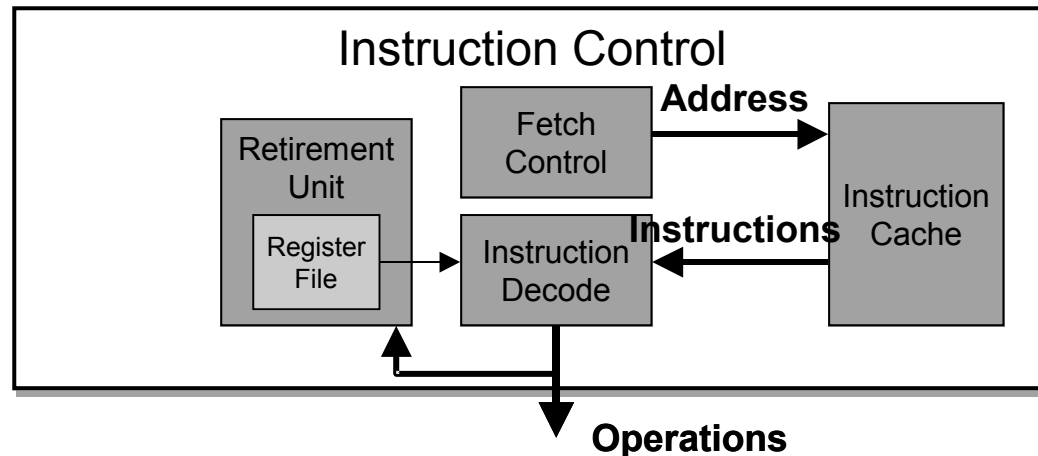

Grabs Instruction Bytes From Memory

- Based on Current PC + Predicted Targets for Predicted Branches
- Hardware dynamically guesses whether branches taken/not taken and (possibly) branch target

Translates Instructions Into *Operations*

- Primitive steps required to perform instruction
- Typical instruction requires 1–3 operations

Converts Register References Into *Tags*

- Abstract identifier linking destination of one operation with sources of later operations

Execution Unit

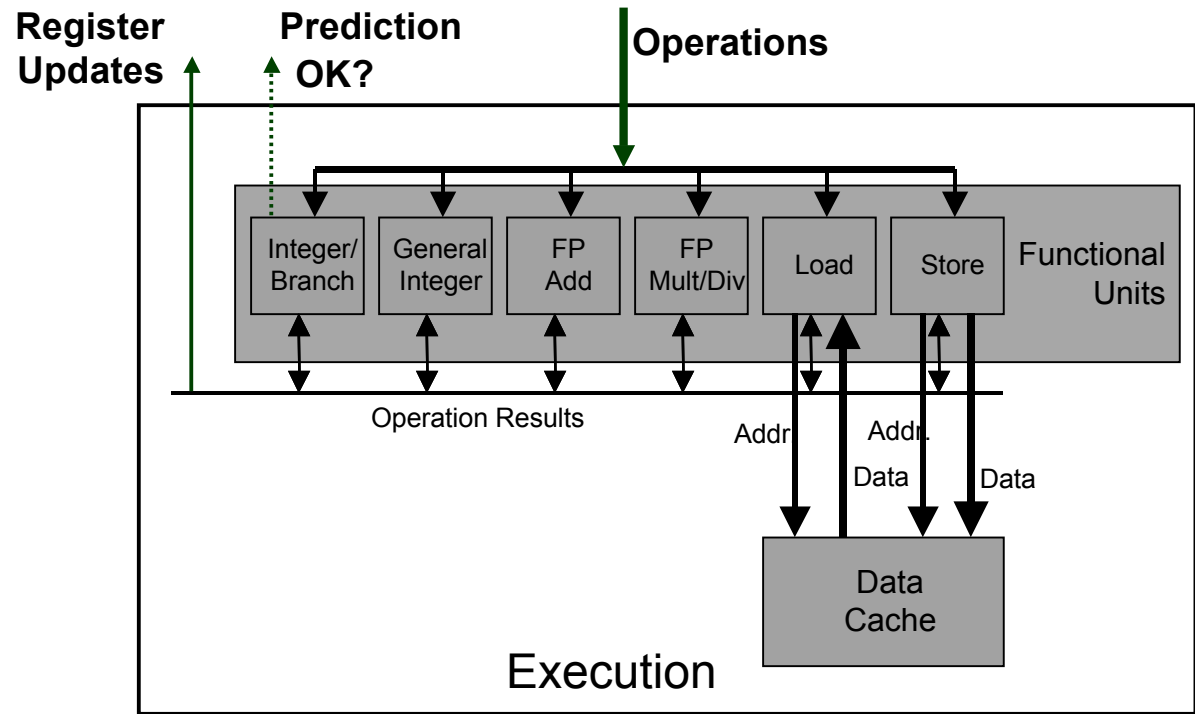

- **Multiple functional units**
 - Each can operate independently
- **Operations performed as soon as operands available**
 - Not necessarily in program order
 - Within limits of functional units
- **Control logic**
 - Ensures behavior equivalent to sequential program execution

CPU Capabilities of Pentium III

Multiple Instructions Can Execute in Parallel

- 1 load
- 1 store
- 2 integer (one may be branch)
- 1 FP Addition
- 1 FP Multiplication or Division

Some Instructions Take > 1 Cycle, but Can be Pipelined

■ Instruction	Latency	Cycles/Issue
■ Load / Store	3	1
■ Integer Multiply	4	1
■ Integer Divide	36	36
■ Double/Single FP Multiply	5	2
■ Double/Single FP Add	3	1
■ Double/Single FP Divide	38	38

PentiumPro Block Diagram

P6 Microarchitecture

- PentiumPro
- Pentium II
- Pentium III

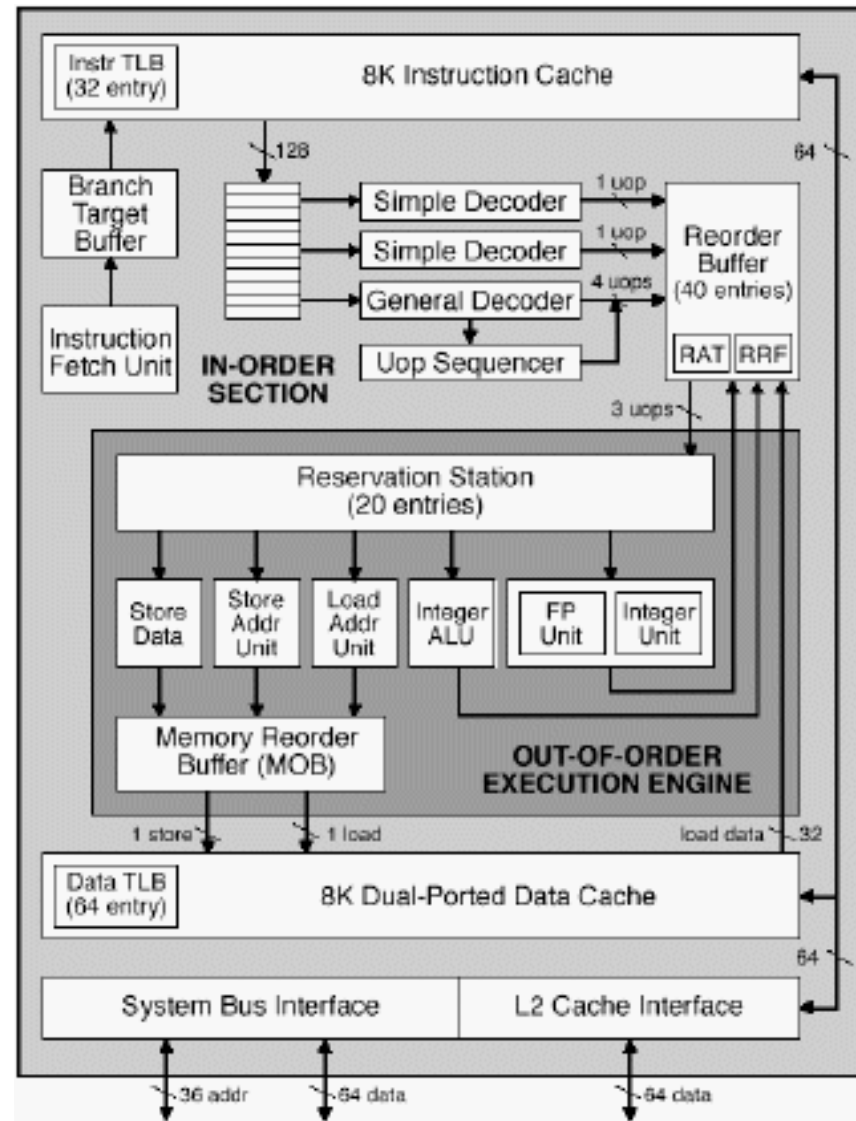

Microprocessor Report
2/16/95

PentiumPro Operation

Translates instructions dynamically into “Uops”

- 118 bits wide
- Holds operation, two sources, and destination

Executes Uops with “Out of Order” engine

- Uop executed when
 - Operands available
 - Functional unit available
- Execution controlled by “Reservation Stations”
 - Keeps track of data dependencies between uops
 - Allocates resources

PentiumPro Branch Prediction

Critical to Performance

- 11–15 cycle penalty for misprediction

Branch Target Buffer

- 512 entries
- 4 bits of history
- Adaptive algorithm
 - Can recognize repeated patterns, e.g., alternating taken–not taken

Handling BTB misses

- Detect in cycle 6
- Predict taken for negative offset, not taken for positive
 - Loops vs. conditionals

Example Branch Prediction

Branch History

- Encode information about prior history of branch instructions
- Predict whether or not branch will be taken

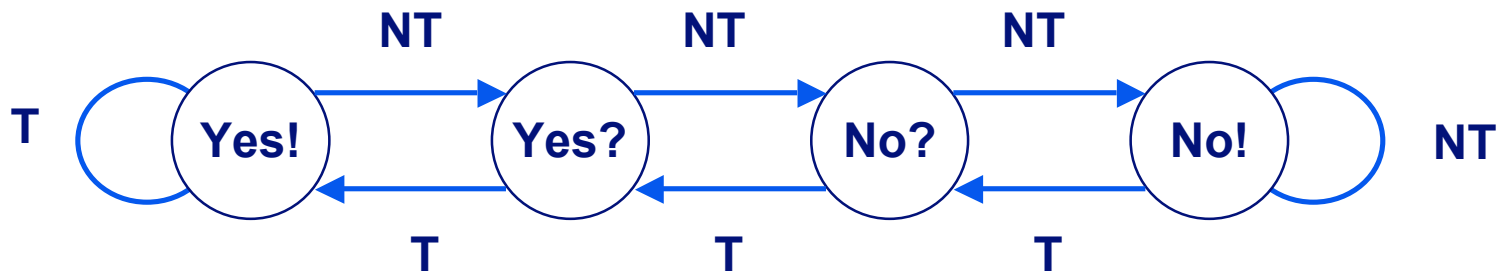

State Machine

- Each time branch taken, transition to right
- When not taken, transition to left
- Predict branch taken when in state Yes! or Yes?

Pentium 4 Block Diagram

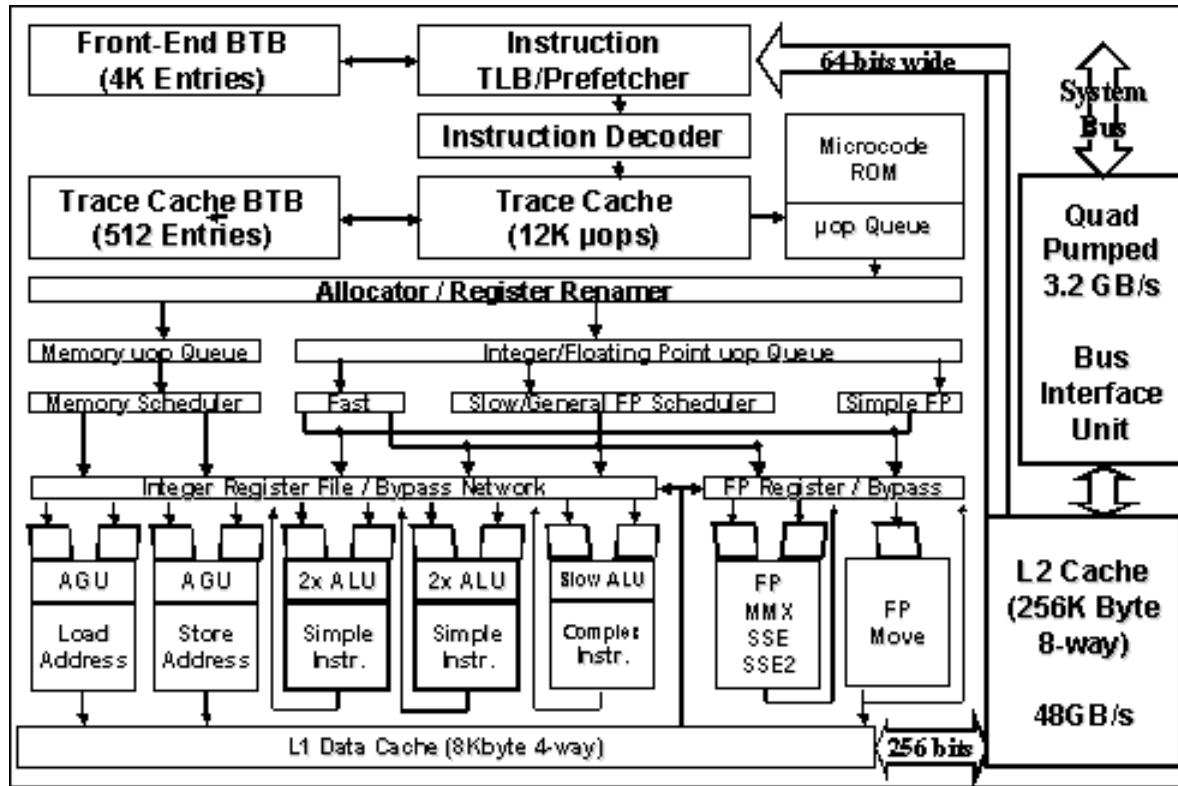

Intel Tech. Journal
Q1, 2001

■ Next generation microarchitecture

Pentium 4 Features

Trace Cache

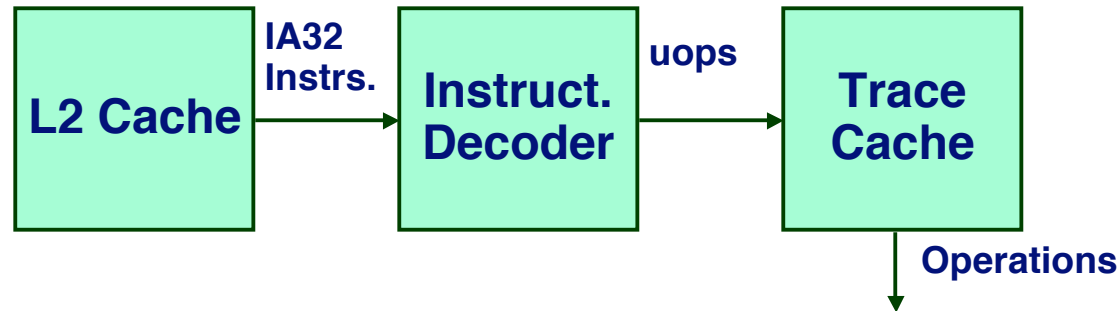

- Replaces traditional instruction cache
- Caches instructions in decoded form
- Reduces required rate for instruction decoder

Double-Pumped ALUs

- Simple instructions (add) run at 2X clock rate

Very Deep Pipeline

- 20+ cycle branch penalty
- Enables very high clock rates
- Slower than Pentium III for a given clock rate

Processor Summary

Design Technique

- Create uniform framework for all instructions
 - Want to share hardware among instructions
- Connect standard logic blocks with bits of control logic

Operation

- State held in memories and clocked registers
- Computation done by combinational logic
- Clocking of registers/memories sufficient to control overall behavior

Enhancing Performance

- Pipelining increases throughput and improves resource utilization
- Must make sure maintains ISA behavior