

15-213

“The course that gives CMU its Zip!”

System-Level I/O

Nov 14, 2002

Topics

- Unix I/O
- Robust reading and writing
- Reading file metadata
- Sharing files
- I/O redirection
- Standard I/O

A Typical Hardware System

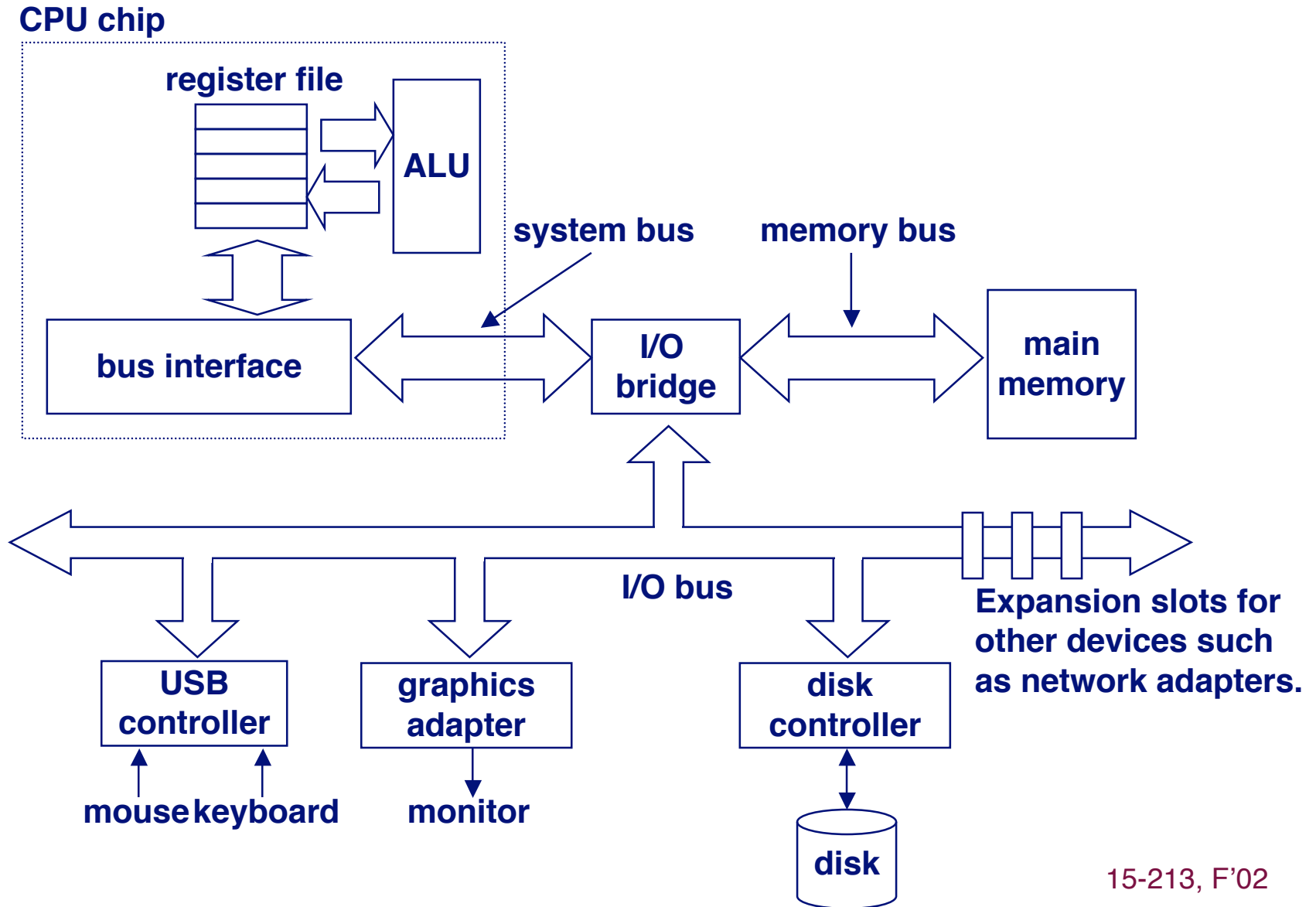

Reading a Disk Sector: Step 1

CPU chip

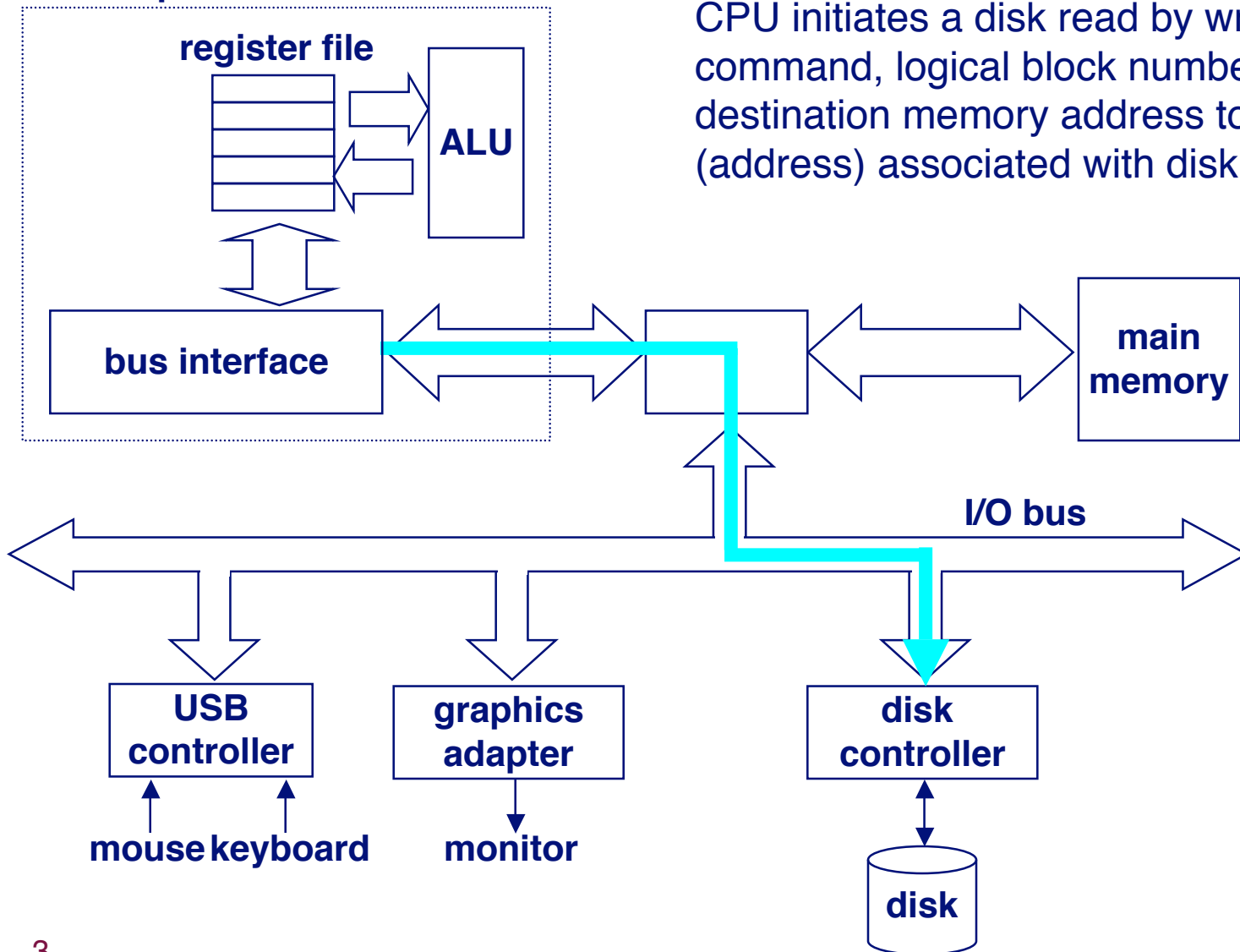

Reading a Disk Sector: Step 2

CPU chip

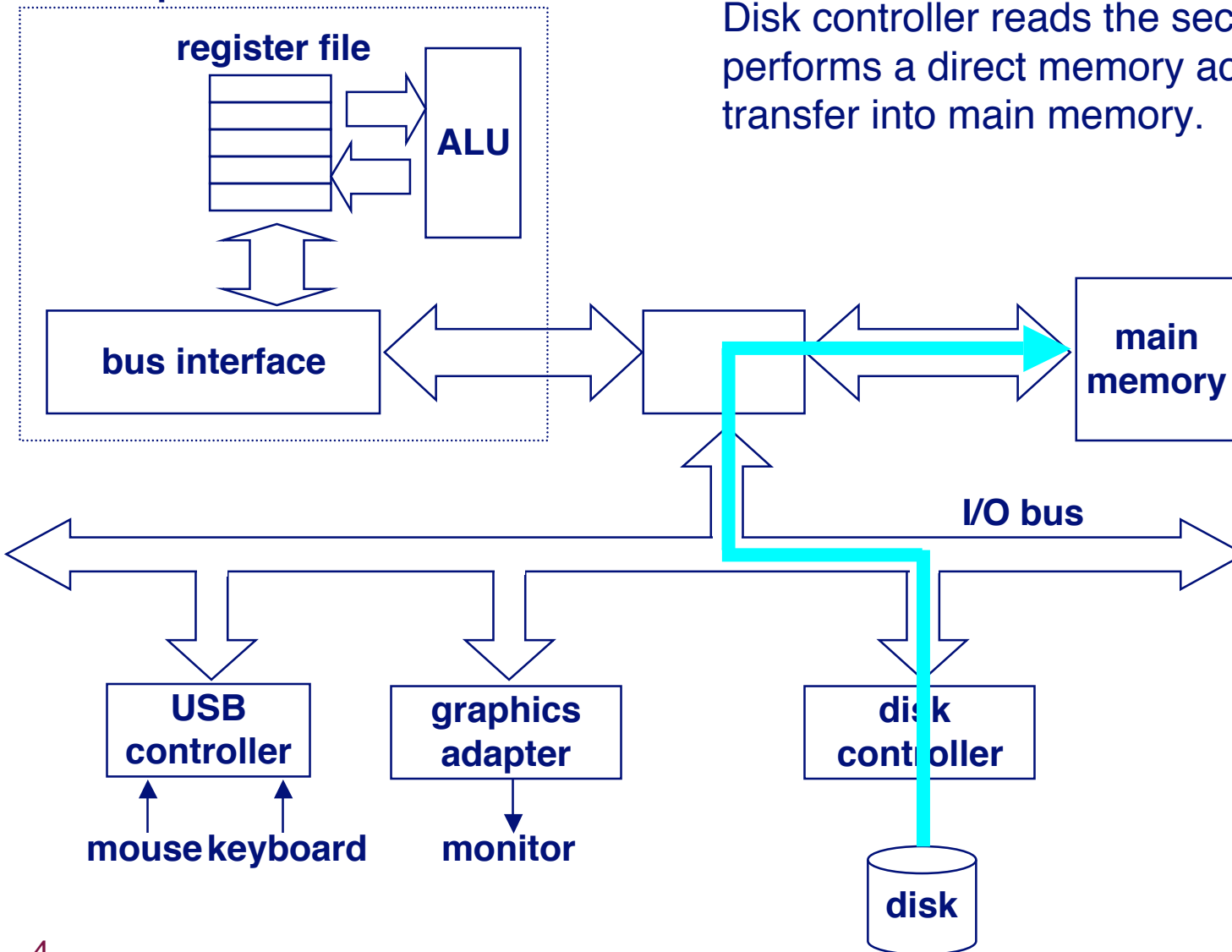

Reading a Disk Sector: Step 3

CPU chip

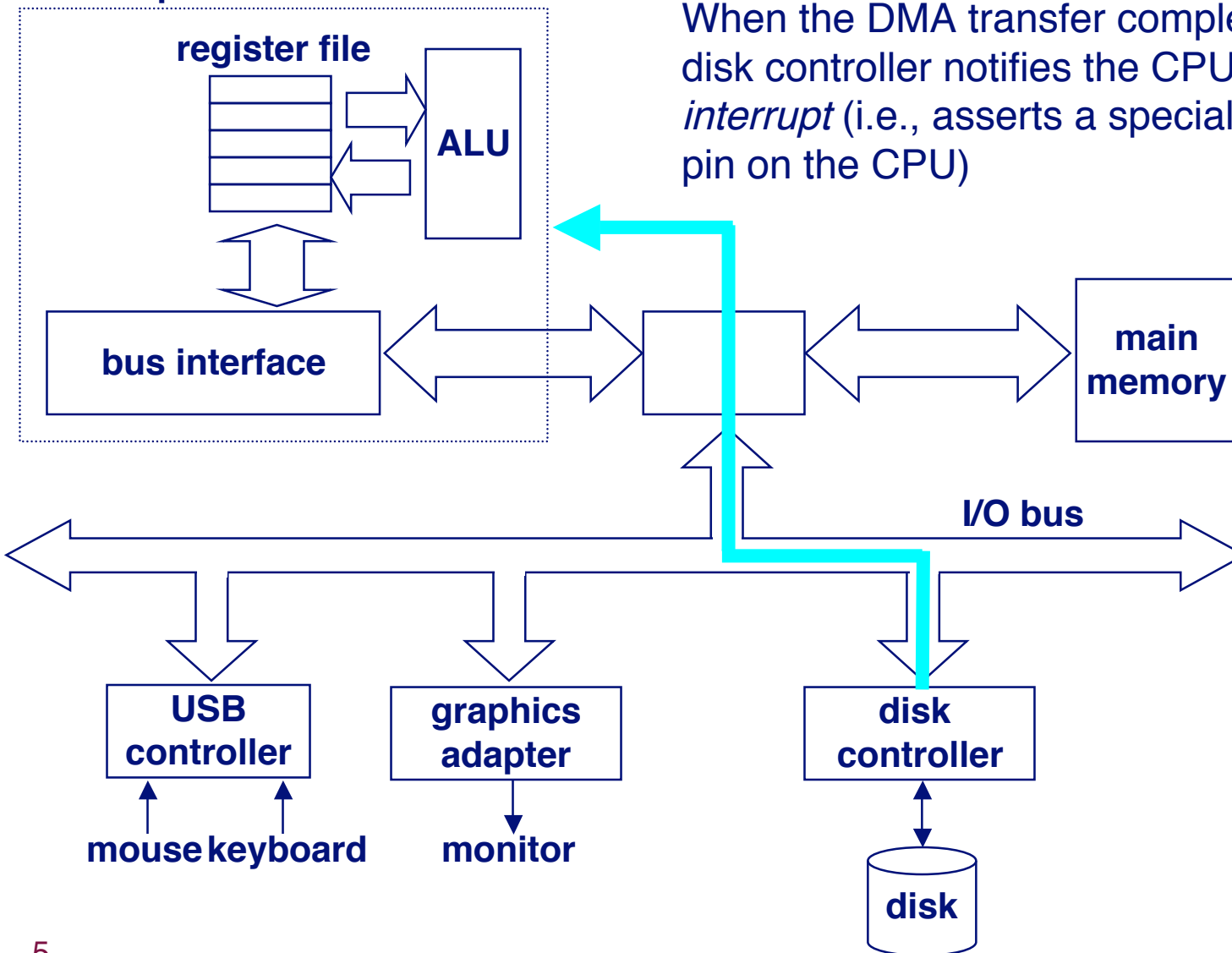

When the DMA transfer completes, the disk controller notifies the CPU with an *interrupt* (i.e., asserts a special “interrupt” pin on the CPU)

Unix Files

A Unix *file* is a sequence of m bytes:

- $B_0, B_1, \dots, B_k, \dots, B_{m-1}$

All I/O devices are represented as files:

- `/dev/sda2` (/usr disk partition)
- `/dev/tty2` (terminal)

Even the kernel is represented as a file:

- `/dev/kmem` (kernel memory image)
- `/proc` (kernel data structures)

Unix File Types

Regular file

- Binary or text file.
- Unix does not know the difference!

Directory file

- A file that contains the names and locations of other files.

Character special and block special files

- Terminals (character special) and disks (block special)

FIFO (named pipe)

- A file type used for interprocess communication

Socket

- A file type used for network communication between processes

Unix I/O

The elegant mapping of files to devices allows kernel to export simple interface called Unix I/O.

Key Unix idea: All input and output is handled in a consistent and uniform way.

Basic Unix I/O operations (system calls):

- Opening and closing files
 - `open()` and `close()`
- Changing the *current file position* (`seek`)
 - `lseek` (not discussed)
- Reading and writing a file
 - `read()` and `write()`

Opening Files

Opening a file informs the kernel that you are getting ready to access that file.

```
int fd;    /* file descriptor */

if ((fd = open("/etc/hosts", O_RDONLY)) < 0) {
    perror("open");
    exit(1);
}
```

Returns a small identifying integer *file descriptor*

- `fd == -1` indicates that an error occurred

Each process created by a Unix shell begins life with three open files associated with a terminal:

- 0: standard input
- 1: standard output
- 2: standard error

Closing Files

Closing a file informs the kernel that you are finished accessing that file.

```
int fd;      /* file descriptor */
int retval; /* return value */

if ((retval = close(fd)) < 0) {
    perror("close");
    exit(1);
}
```

Closing an already closed file is a recipe for disaster in threaded programs (more on this later)

Moral: Always check return codes, even for seemingly benign functions such as `close()`

Reading Files

Reading a file copies bytes from the current file position to memory, and then updates file position.

```
char buf[512];
int fd;          /* file descriptor */
int nbytes;     /* number of bytes read */

/* Open file fd ... */
/* Then read up to 512 bytes from file fd */
if ((nbytes = read(fd, buf, sizeof(buf))) < 0) {
    perror("read");
    exit(1);
}
```

Returns number of bytes read from file `fd` into `buf`

- `nbytes < 0` indicates that an error occurred.
- **short counts** (`nbytes < sizeof(buf)`) are possible and are not errors!

Writing Files

Writing a file copies bytes from memory to the current file position, and then updates current file position.

```
char buf[512];
int fd;      /* file descriptor */
int nbytes; /* number of bytes read */

/* Open the file fd ... */
/* Then write up to 512 bytes from buf to file fd */
if ((nbytes = write(fd, buf, sizeof(buf))) < 0) {
    perror("write");
    exit(1);
}
```

Returns number of bytes written from `buf` to file `fd`.

- `nbytes < 0` indicates that an error occurred.
- As with reads, short counts are possible and are not errors!

Transfers up to 512 bytes from address `buf` to file `fd`

Unix I/O Example

Copying standard input to standard output one byte at a time.

```
#include "csapp.h"

int main(void)
{
    char c;

    while(Read(STDIN_FILENO, &c, 1) != 0)
        Write(STDOUT_FILENO, &c, 1);
    exit(0);
}
```

Note the use of error handling wrappers for read and write (Appendix B).

Dealing with Short Counts

Short counts can occur in these situations:

- Encountering (end-of-file) EOF on reads.
- Reading text lines from a terminal.
- Reading and writing network sockets or Unix pipes.

Short counts never occur in these situations:

- Reading from disk files (except for EOF)
- Writing to disk files.

How should you deal with short counts in your code?

- Use the RIO (Robust I/O) package from your textbook's `csapp.c` file (Appendix B).

The RIO Package

RIO is a set of wrappers that provide efficient and robust I/O in applications such as network programs that are subject to short counts.

RIO provides two different kinds of functions

- Unbuffered input and output of binary data
 - `rio_readn` and `rio_writen`
- Buffered input of binary data and text lines
 - `rio_readlineb` and `rio_readnb`
 - Cleans up some problems with Stevens's `readline` and `readn` functions.
 - Unlike the Stevens routines, the buffered RIO routines are *thread-safe* and can be interleaved arbitrarily on the same descriptor.

Download from

```
csapp.cs.cmu.edu/public/ics/code/src/csapp.c  
csapp.cs.cmu.edu/public/ics/code/include/csapp.h
```

Unbuffered RIO Input and Output

Same interface as Unix `read` and `write`

Especially useful for transferring data on network sockets

```
#include "csapp.h"
```

```
ssize_t rio_readn(int fd, void *usrbuf, size_t n);
```

```
ssize_t rio_writen(int fd, void *usrbuf, size_t n);
```

Return: num. bytes transferred if OK, 0 on EOF (`rio_readn` only), -1 on error

- `rio_readn` returns short count only it encounters EOF.
- `rio_writen` never returns a short count.
- Calls to `rio_readn` and `rio_writen` can be interleaved arbitrarily on the same descriptor.

Implementation of `rio_readn`

```
/*
 * rio_readn - robustly read n bytes (unbuffered)
 */
ssize_t rio_readn(int fd, void *usrbuf, size_t n)
{
    size_t nleft = n;
    ssize_t nread;
    char *bufp = usrbuf;

    while (nleft > 0) {
        if ((nread = read(fd, bufp, nleft)) < 0) {
            if (errno == EINTR) /* interrupted by sig
                                handler return */
                nread = 0;      /* and call read() again */
            else
                return -1;     /* errno set by read() */
        }
        else if (nread == 0)
            break;             /* EOF */
        nleft -= nread;
        bufp += nread;
    }
    return (n - nleft);       /* return >= 0 */
}
```

Buffered RIO Input Functions

Efficiently read text lines and binary data from a file partially cached in an internal memory buffer

```
#include "csapp.h"

void rio_readinitb(rio_t *rp, int fd);

ssize_t rio_readlineb(rio_t *rp, void *usrbuf, size_t maxlen);
ssize_t rio_readnb(rio_t *rp, void *usrbuf, size_t n);
```

Return: num. bytes read if OK, 0 on EOF, -1 on error

- `rio_readlineb` reads a text line of up to `maxlen` bytes from file `fd` and stores the line in `usrbuf`.
 - Especially useful for reading text lines from network sockets.
- `rio_readnb` reads up to `n` bytes from file `fd`.
- Calls to `rio_readlineb` and `rio_readnb` can be interleaved arbitrarily on the same descriptor.
 - Warning: Don't interleave with calls to `rio_readn`

RIO Example

Copying the lines of a text file from standard input to standard output.

```
#include "csapp.h"

int main(int argc, char **argv)
{
    int n;
    rio_t rio;
    char buf[MAXLINE];

    Rio_readinitb(&rio, STDIN_FILENO);
    while((n = Rio_readlineb(&rio, buf, MAXLINE)) != 0)
        Rio_writen(STDOUT_FILENO, buf, n);
    exit(0);
}
```

File Metadata

Metadata is data about data, in this case file data.

Maintained by kernel, accessed by users with the `stat` and `fstat` functions.

```
/* Metadata returned by the stat and fstat functions */
struct stat {
    dev_t      st_dev;      /* device */
    ino_t      st_ino;     /* inode */
    mode_t     st_mode;    /* protection and file type */
    nlink_t    st_nlink;   /* number of hard links */
    uid_t      st_uid;     /* user ID of owner */
    gid_t      st_gid;     /* group ID of owner */
    dev_t      st_rdev;    /* device type (if inode device) */
    off_t      st_size;    /* total size, in bytes */
    unsigned long st_blksize; /* blocksize for filesystem I/O */
    unsigned long st_blocks; /* number of blocks allocated */
    time_t     st_atime;   /* time of last access */
    time_t     st_mtime;   /* time of last modification */
    time_t     st_ctime;   /* time of last change */
};
```

Example of Accessing File Metadata

```
/* statcheck.c - Querying and manipulating a file's meta data */
#include "csapp.h"

int main (int argc, char **argv)
{
    struct stat stat;
    char *type, *readok;

    Stat(argv[1], &stat);
    if (S_ISREG(stat.st_mode)) /* file type*/
        type = "regular";
    else if (S_ISDIR(stat.st_mode))
        type = "directory";
    else
        type = "other";
    if ((stat.st_mode & S_IRUSR)) /* OK to read?*/
        readok = "yes";
    else
        readok = "no";

    printf("type: %s, read: %s\n", type, readok);
    exit(0);
}
```

```
bass> ./statcheck statcheck.c
type: regular, read: yes
bass> chmod 000 statcheck.c
bass> ./statcheck statcheck.c
type: regular, read: no
```

How the Unix Kernel Represents Open Files

Two descriptors referencing two distinct open disk files. Descriptor 1 (stdout) points to terminal, and descriptor 4 points to open disk file.

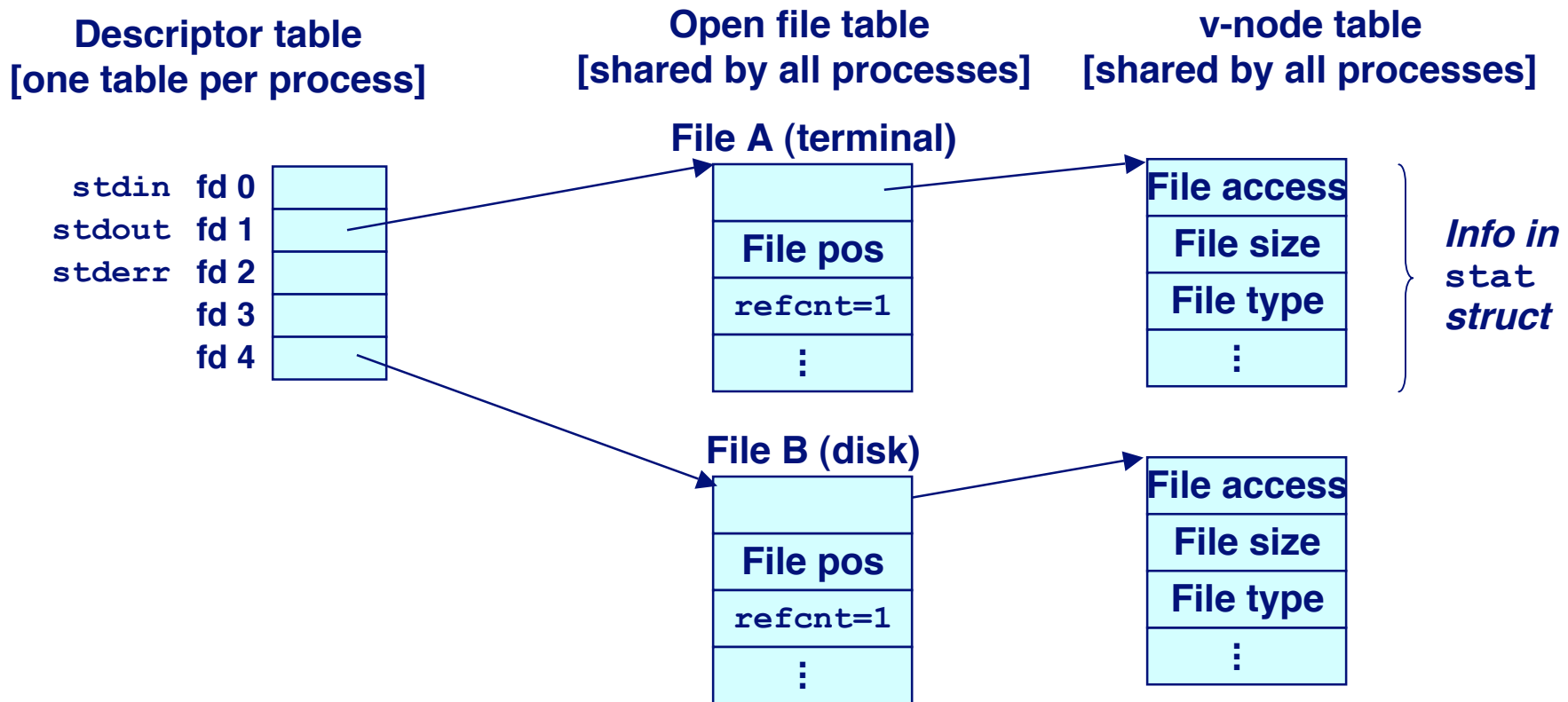

File Sharing

Two distinct descriptors sharing the same disk file through two distinct open file table entries

- E.g., Calling `open` twice with the same `filename` argument

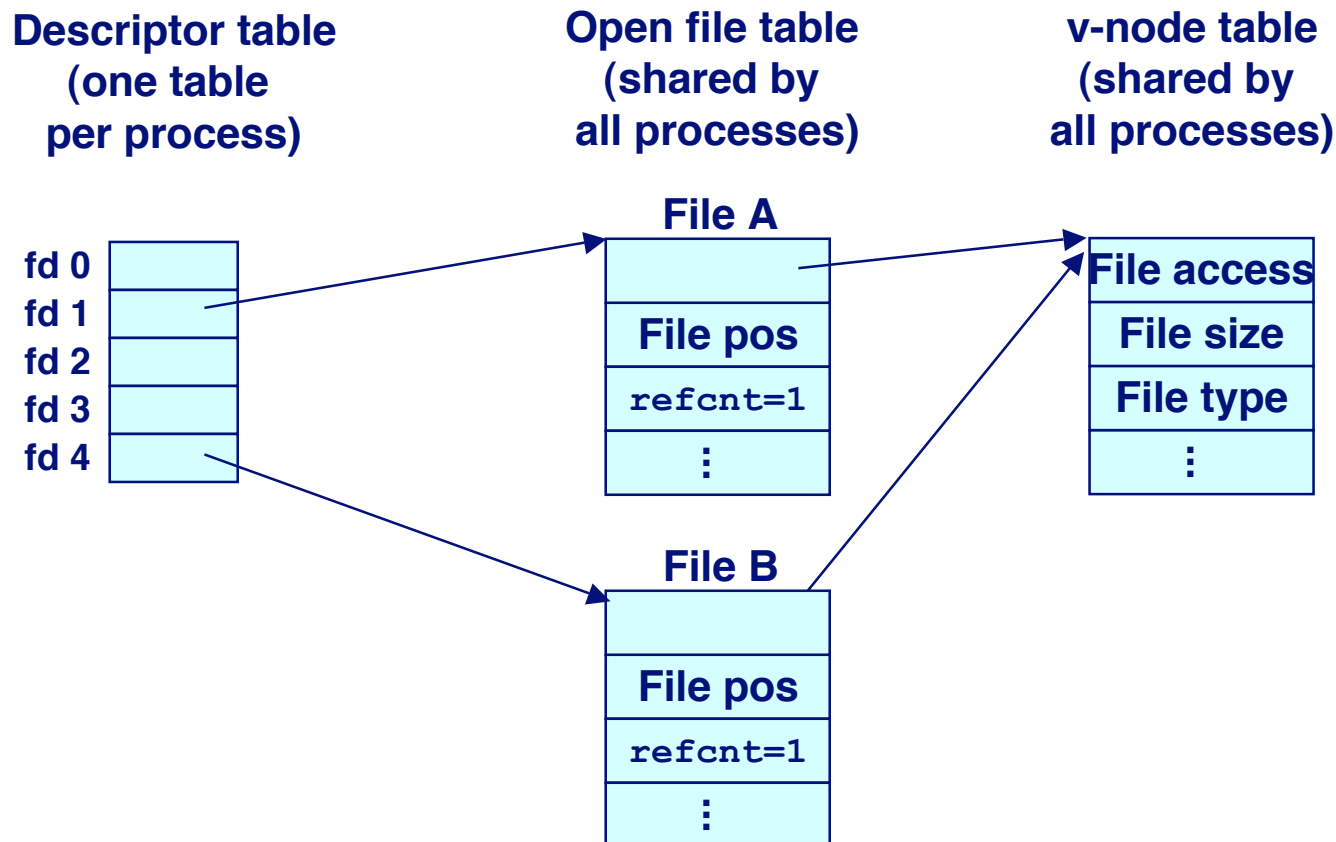

How Processes Share Files

A child process inherits its parent's open files. Here is the situation immediately after a `fork`

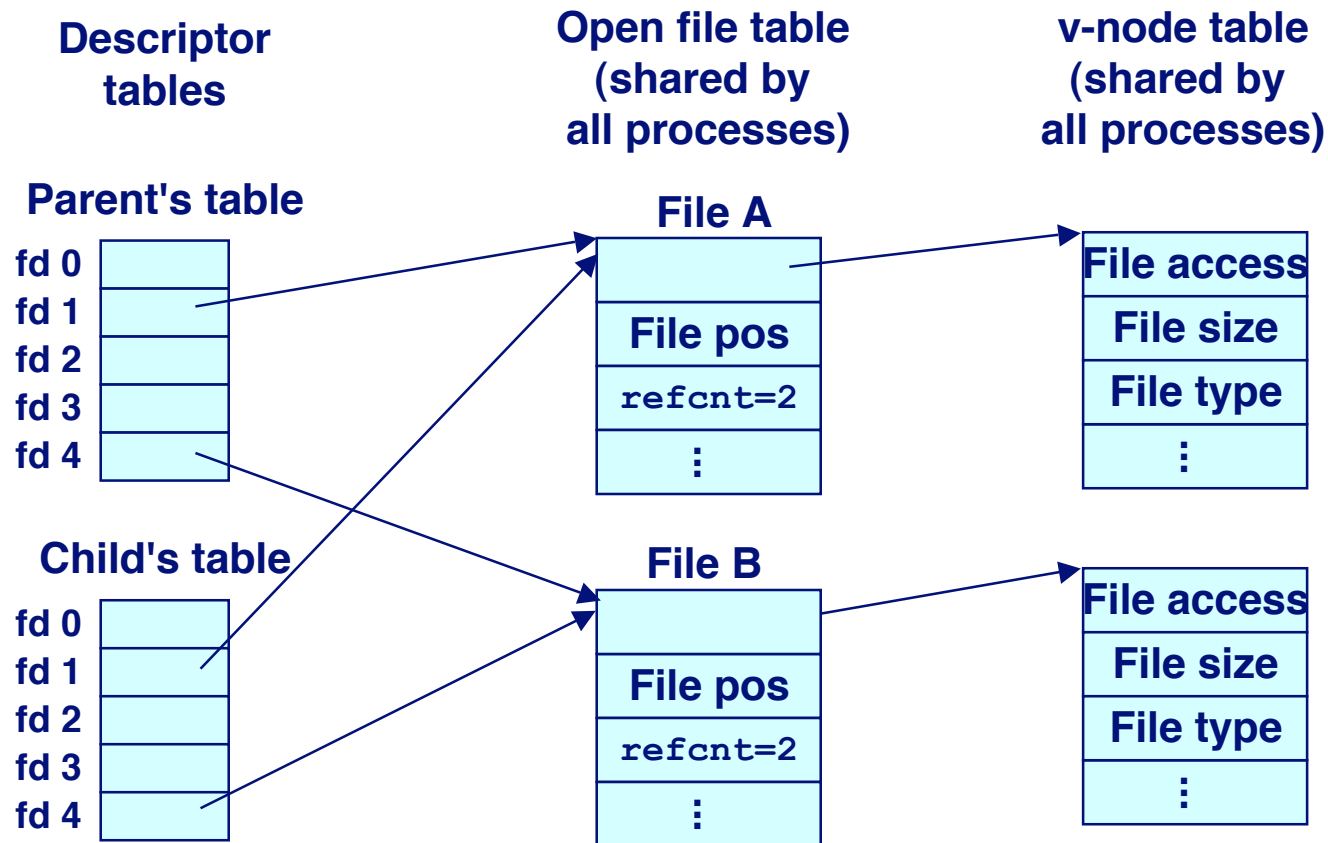

I/O Redirection

Question: How does a shell implement I/O redirection?

```
unix> ls > foo.txt
```

Answer: By calling the dup2 (oldfd, newfd) function

- Copies (per-process) descriptor table entry oldfd to entry newfd

Descriptor table
before dup2 (4, 1)

fd 0	
fd 1	a
fd 2	
fd 3	
fd 4	b



Descriptor table
after dup2 (4, 1)

fd 0	
fd 1	b
fd 2	
fd 3	
fd 4	b

I/O Redirection Example

Before calling `dup2 (4 , 1)`, `stdout` (descriptor 1) points to a terminal and descriptor 4 points to an open disk file.

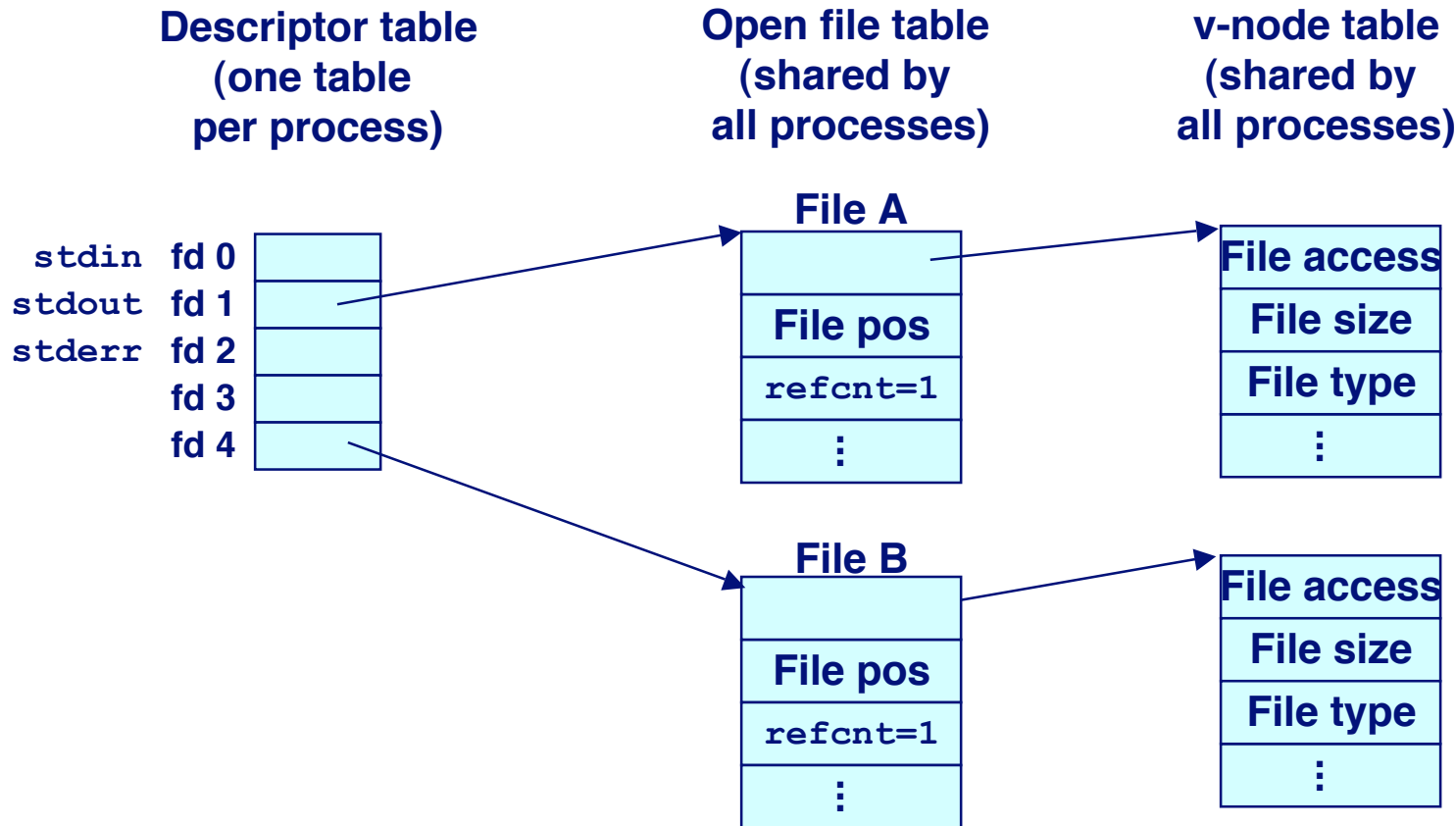

I/O Redirection Example (cont)

After calling `dup2 (4 , 1)`, `stdout` is now redirected to the disk file pointed at by descriptor 4.

Descriptor table
(one table
per process)

fd 0	
fd 1	
fd 2	
fd 3	
fd 4	

Open file table
(shared by
all processes)

File A
File pos
refcnt=0
⋮

v-node table
(shared by
all processes)

File access
File size
File type
⋮

File B
File pos
refcnt=2
⋮

File access
File size
File type
⋮

Standard I/O Functions

The C standard library (`libc.a`) contains a collection of higher-level **standard I/O** functions

- Documented in Appendix B of K&R.

Examples of standard I/O functions:

- Opening and closing files (`fopen` and `fclose`)
- Reading and writing bytes (`fread` and `fwrite`)
- Reading and writing text lines (`fgets` and `fputs`)
- Formatted reading and writing (`fscanf` and `fprintf`)

Standard I/O Streams

Standard I/O models open files as *streams*

- Abstraction for a file descriptor and a buffer in memory.

C programs begin life with three open streams (defined in `stdio.h`)

- `stdin` (standard input)
- `stdout` (standard output)
- `stderr` (standard error)

```
#include <stdio.h>
extern FILE *stdin; /* standard input (descriptor 0) */
extern FILE *stdout; /* standard output (descriptor 1) */
extern FILE *stderr; /* standard error (descriptor 2) */

int main() {
    fprintf(stdout, "Hello, world\n");
}
```

Buffering in Standard I/O

Standard I/O functions use buffered I/O

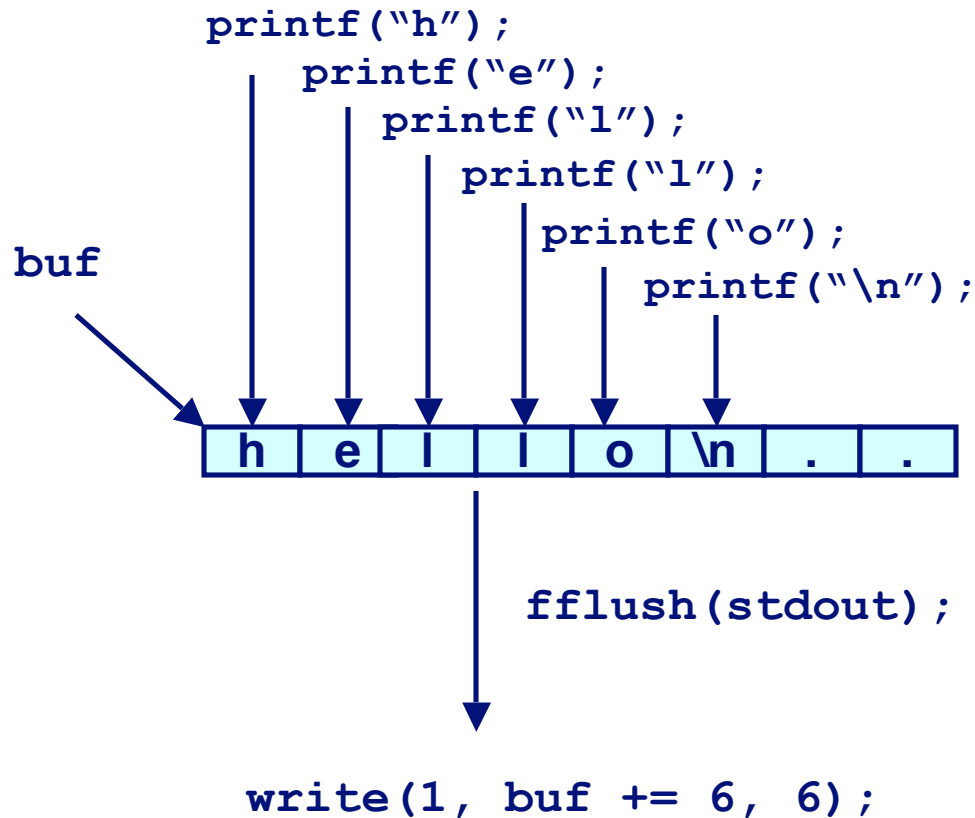

Standard I/O Buffering in Action

You can see this buffering in action for yourself, using the always fascinating Unix `strace` program:

```
#include <stdio.h>

int main()
{
    printf("h");
    printf("e");
    printf("l");
    printf("l");
    printf("o");
    printf("\n");
    fflush(stdout);
    exit(0);
}
```

```
linux> strace ./hello
execve("./hello", ["hello"], [/* ... */]).
...
write(1, "hello\n", 6...)           = 6
...
_exit(0)                             = ?
```

Unix I/O vs. Standard I/O vs. RIO

Standard I/O and RIO are implemented using low-level Unix I/O.

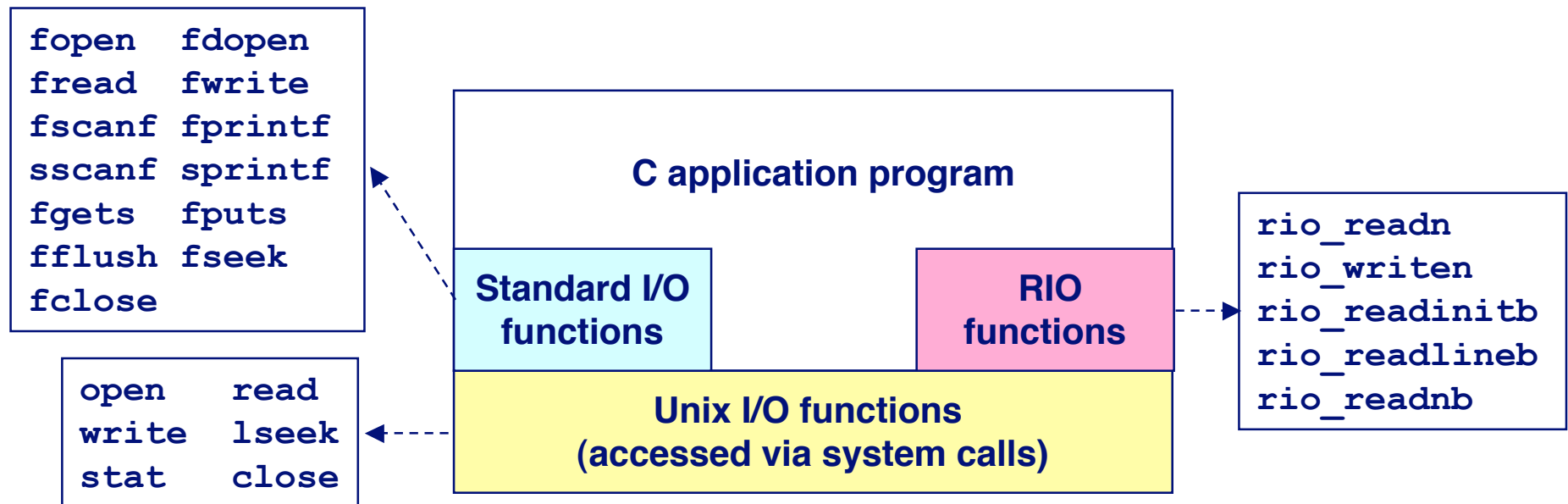

Which ones should you use in your programs?

Pros and Cons of Unix I/O

Pros

- Unix I/O is the most general and lowest overhead form of I/O.
 - All other I/O packages are implemented using Unix I/O functions.
- Unix I/O provides functions for accessing file metadata.

Cons

- Dealing with short counts is tricky and error prone.
- Efficient reading of text lines requires some form of buffering, also tricky and error prone.
- Both of these issues are addressed by the standard I/O and RIO packages.

Pros and Cons of Standard I/O

Pros:

- Buffering increases efficiency by decreasing the number of `read` and `write` system calls.
- Short counts are handled automatically.

Cons:

- Provides no function for accessing file metadata
- Standard I/O is not appropriate for input and output on network sockets
- There are poorly documented restrictions on streams that interact badly with restrictions on sockets

Pros and Cons of Standard I/O (cont)

Restrictions on streams:

- **Restriction 1:** input function cannot follow output function without intervening call to `fflush`, `fseek`, `fsetpos`, or `rewind`.
 - Latter three functions all use `lseek` to change file position.
- **Restriction 2:** output function cannot follow an input function with intervening call to `fseek`, `fsetpos`, or `rewind`.

Restriction on sockets:

- You are not allowed to change the file position of a socket.

Pros and Cons of Standard I/O (cont)

Workaround for restriction 1:

- Flush stream after every output.

Workaround for restriction 2:

- Open two streams on the same descriptor, one for reading and one for writing:

```
FILE *fpin, *fpout;  
  
fpin = fdopen(sockfd, "r");  
fpout = fdopen(sockfd, "w");
```

- However, this requires you to close the same descriptor twice:

```
fclose(fpin);  
fclose(fpout);
```

- Creates a deadly race in concurrent threaded programs!

Choosing I/O Functions

General rule: Use the highest-level I/O functions you can.

- Many C programmers are able to do all of their work using the standard I/O functions.

When to use standard I/O?

- When working with disk or terminal files.

When to use raw Unix I/O

- When you need to fetch file metadata.
- In rare cases when you need absolute highest performance.

When to use RIO?

- When you are reading and writing network sockets or pipes.
- Never use standard I/O or raw Unix I/O on sockets or pipes.

For Further Information

The Unix bible:

- W. Richard Stevens, *Advanced Programming in the Unix Environment*, Addison Wesley, 1993.
- Somewhat dated, but still useful.

Stevens is arguably the best technical writer ever.

- Produced authoritative works in:
 - Unix programming
 - TCP/IP (the protocol that makes the Internet work)
 - Unix network programming
 - Unix IPC programming.

Tragically, Stevens died Sept 1, 1999.