

15-213

“The course that gives CMU its Zip!”

Code Optimization II: Machine Dependent Optimizations

Oct. 1, 2002

Topics

- **Machine-Dependent Optimizations**
 - **Pointer code**
 - **Unrolling**
 - **Enabling instruction level parallelism**
- **Understanding Processor Operation**
 - **Translation of instructions into operations**
 - **Out-of-order execution of operations**
- **Branches and Branch Prediction**
- **Advice**

Previous Best Combining Code

```
void combine4(vec_ptr v, int *dest)
{
    int i;
    int length = vec_length(v);
    int *data = get_vec_start(v);
    int sum = 0;
    for (i = 0; i < length; i++)
        sum += data[i];
    *dest = sum;
}
```

Task

- Compute sum of all elements in vector
- Vector represented by C-style abstract data type
- Achieved CPE of 2.00
 - Cycles per element

General Forms of Combining

```
void abstract_combine4(vec_ptr v, data_t *dest)
{
    int i;
    int length = vec_length(v);
    data_t *data = get_vec_start(v);
    data_t t = IDENT;
    for (i = 0; i < length; i++)
        t = t OP data[i];
    *dest = t;
}
```

Data Types

- Use different declarations for data_t
- int
- float
- double

Operations

- Use different definitions of OP and IDENT
- + / 0
- * / 1

Machine Independent Opt. Results

Optimizations

- Reduce function calls and memory references within loop

Method	Integer		Floating Point	
	+	*	+	*
Abstract -g	42.06	41.86	41.44	160.00
Abstract -O2	31.25	33.25	31.25	143.00
Move vec_length	20.66	21.25	21.15	135.00
data access	6.00	9.00	8.00	117.00
Accum. in temp	2.00	4.00	3.00	5.00

Performance Anomaly

- Computing FP product of all elements exceptionally slow.
- Very large speedup when accumulate in temporary
- Caused by quirk of IA32 floating point
 - Memory uses 64-bit format, register use 80
 - Benchmark data caused overflow of 64 bits, but not 80

Pointer Code

```
void combine4p(vec_ptr v, int *dest)
{
    int length = vec_length(v);
    int *data = get_vec_start(v);
    int *dend = data+length;
    int sum = 0;
    while (data < dend) {
        sum += *data;
        data++;
    }
    *dest = sum;
}
```

Optimization

- Use pointers rather than array references
- CPE: 3.00 (Compiled -O2)
 - Oops! We're not making progress here!

Warning: Some compilers do better job optimizing array code

Pointer vs. Array Code Inner Loops

Array Code

```
.L24:                # Loop:
    addl (%eax,%edx,4),%ecx # sum += data[i]
    incl %edx              # i++
    cmpl %esi,%edx        # i:length
    jl  .L24              # if < goto Loop
```

Pointer Code

```
.L30:                # Loop:
    addl (%eax),%ecx      # sum += *data
    addl $4,%eax          # data ++
    cmpl %edx,%eax       # data:dend
    jb  .L30             # if < goto Loop
```

Performance

- **Array Code: 4 instructions in 2 clock cycles**
- **Pointer Code: Almost same 4 instructions in 3 clock cycles**

Modern CPU Design

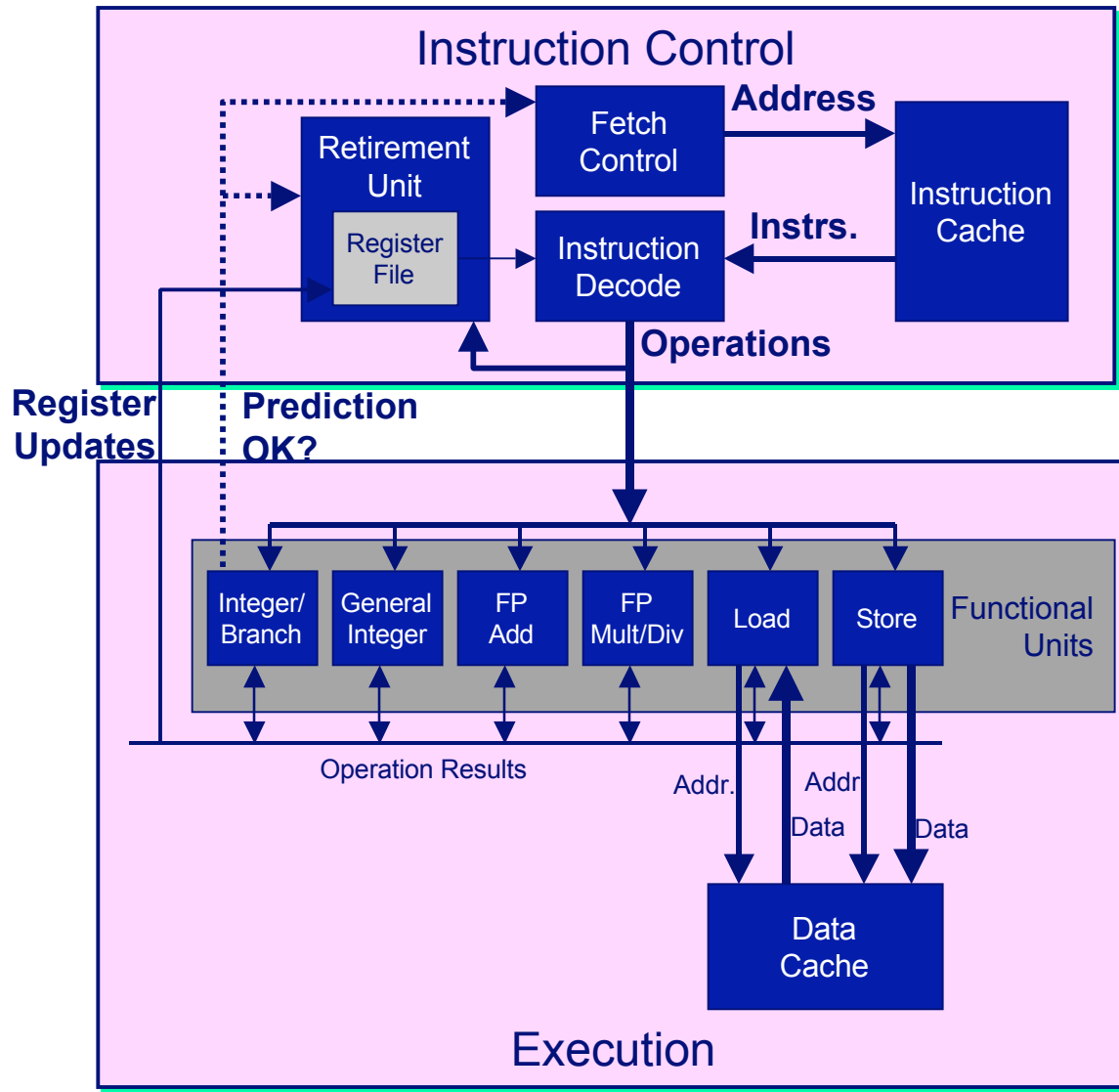

CPU Capabilities of Pentium III

Multiple Instructions Can Execute in Parallel

- 1 load
- 1 store
- 2 integer (one may be branch)
- 1 FP Addition
- 1 FP Multiplication or Division

Some Instructions Take > 1 Cycle, but Can be Pipelined

■ Instruction	Latency	Cycles/Issue
■ Load / Store	3	1
■ Integer Multiply	4	1
■ Integer Divide	36	36
■ Double/Single FP Multiply	5	2
■ Double/Single FP Add	3	1
■ Double/Single FP Divide	38	38

Instruction Control

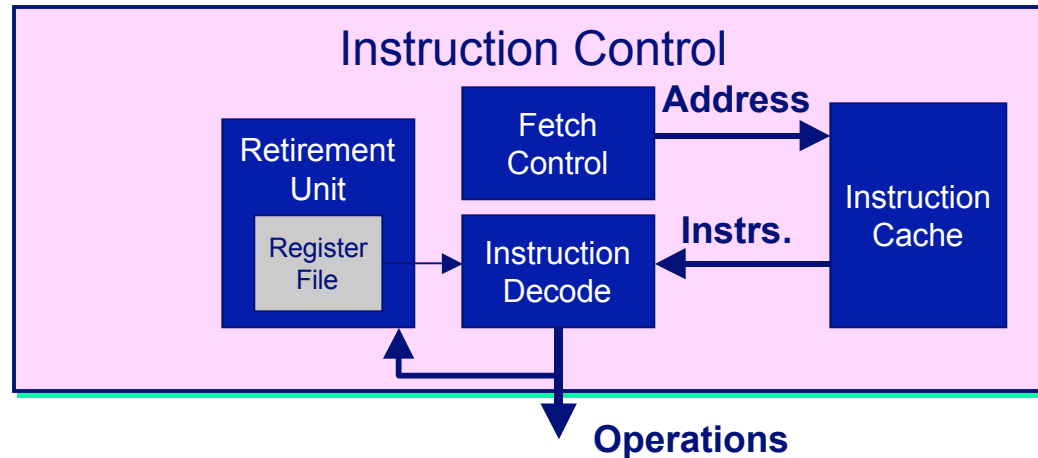

Grabs Instruction Bytes From Memory

- Based on current PC + predicted targets for predicted branches
- Hardware dynamically guesses whether branches taken/not taken and (possibly) branch target

Translates Instructions Into *Operations*

- Primitive steps required to perform instruction
- Typical instruction requires 1–3 operations

Converts Register References Into *Tags*

- Abstract identifier linking destination of one operation with sources of later operations

Translation Example

Version of Combine4

- Integer data, multiply operation

```
.L24:                # Loop:
    imull (%eax,%edx,4),%ecx # t *= data[i]
    incl %edx           # i++
    cmpl %esi,%edx     # i:length
    jl .L24            # if < goto Loop
```

Translation of First Iteration

```
.L24:

    imull (%eax,%edx,4),%ecx

    incl %edx
    cmpl %esi,%edx
    jl .L24
```

```
load (%eax,%edx.0,4) → t.1
imull t.1, %ecx.0    → %ecx.1
incl %edx.0         → %edx.1
cmpl %esi, %edx.1   → cc.1
jl-taken cc.1
```

Translation Example #1

```
imull (%eax,%edx,4),%ecx
```

```
load (%eax,%edx.0,4) → t.1  
imull t.1, %ecx.0 → %ecx.1
```

- Split into two operations
 - load reads from memory to generate temporary result t.1
 - Multiply operation just operates on registers
- Operands
 - Registers %eax does not change in loop. Values will be retrieved from register file during decoding
 - Register %ecx changes on every iteration. Uniquely identify different versions as %ecx.0, %ecx.1, %ecx.2, ...
 - » Register *renaming*
 - » Values passed directly from producer to consumers

Translation Example #2

```
incl %edx
```

```
incl %edx.0 → %edx.1
```

- Register `%edx` changes on each iteration. Rename as `%edx.0`, `%edx.1`, `%edx.2`, ...

Translation Example #3

```
cmp1 %esi,%edx
```

```
cmp1 %esi, %edx.1 → cc.1
```

- Condition codes are treated similar to registers
- Assign tag to define connection between producer and consumer

Translation Example #4

```
jl .L24
```

```
jl-taken cc.1
```

- Instruction control unit determines destination of jump
- Predicts whether will be taken and target
- Starts fetching instruction at predicted destination
- Execution unit simply checks whether or not prediction was OK
- If not, it signals instruction control
 - Instruction control then “invalidates” any operations generated from misfetched instructions
 - Begins fetching and decoding instructions at correct target

Visualizing Operations

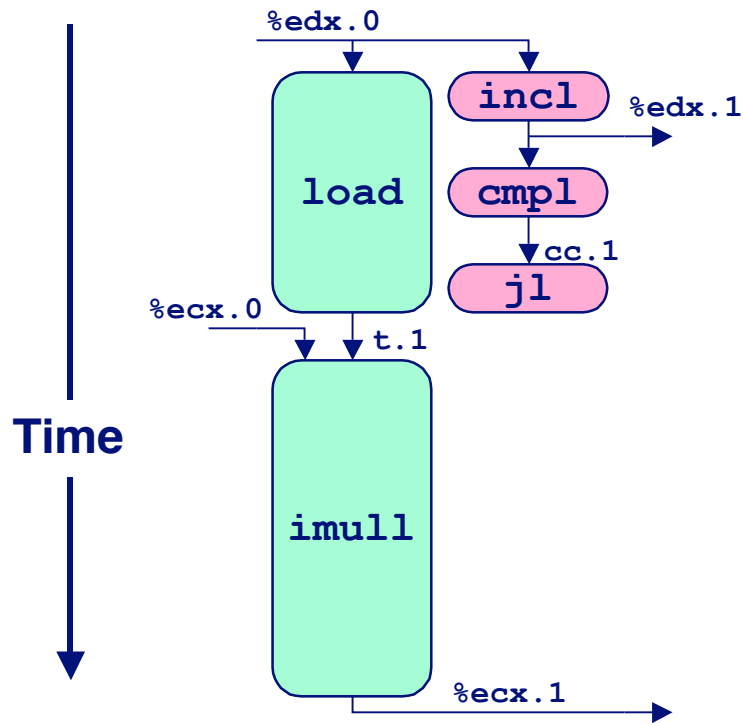

```
load (%eax,%edx,4) → t.1
imull t.1, %ecx.0 → %ecx.1
incl %edx.0 → %edx.1
cml %esi, %edx.1 → cc.1
jl-taken cc.1
```

Operations

- Vertical position denotes time at which executed
 - Cannot begin operation until operands available
- Height denotes latency

Operands

- Arcs shown only for operands that are passed within execution unit

Visualizing Operations (cont.)

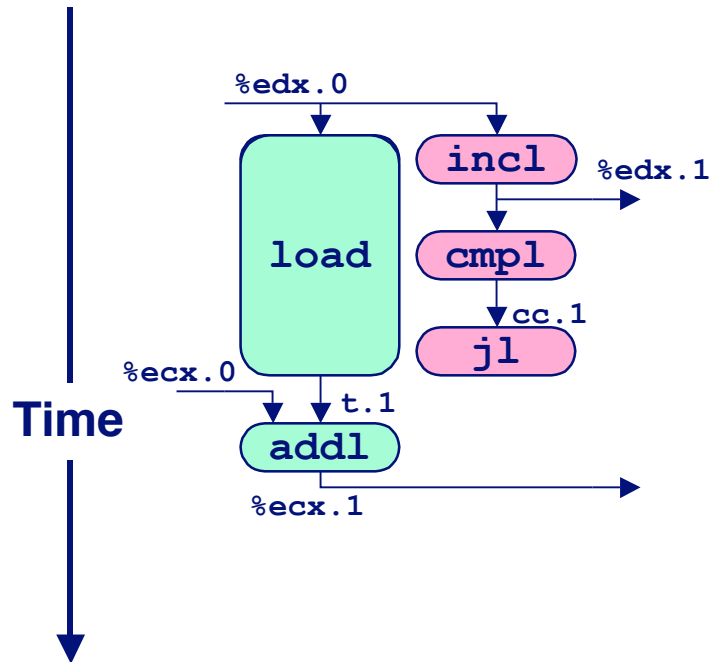

```
load (%eax,%edx,4) → t.1
iaddl t.1, %ecx.0 → %ecx.1
incl %edx.0 → %edx.1
cpl %esi, %edx.1 → cc.1
jl-taken cc.1
```

Operations

- Same as before, except that add has latency of 1

3 Iterations of Combining Product

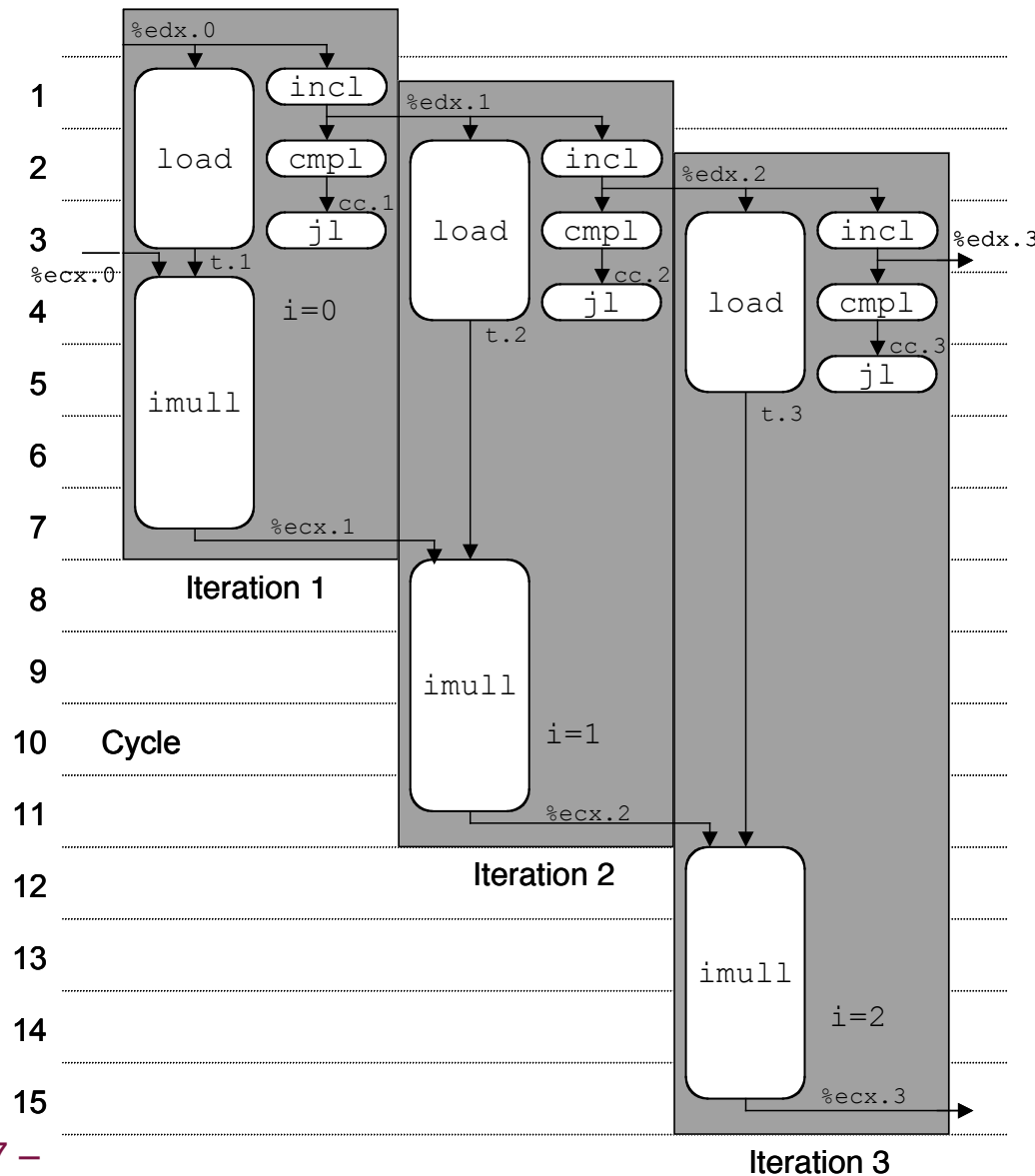

Unlimited Resource Analysis

- Assume operation can start as soon as operands available
- Operations for multiple iterations overlap in time

Performance

- Limiting factor becomes latency of integer multiplier
- Gives CPE of 4.0

4 Iterations of Combining Sum

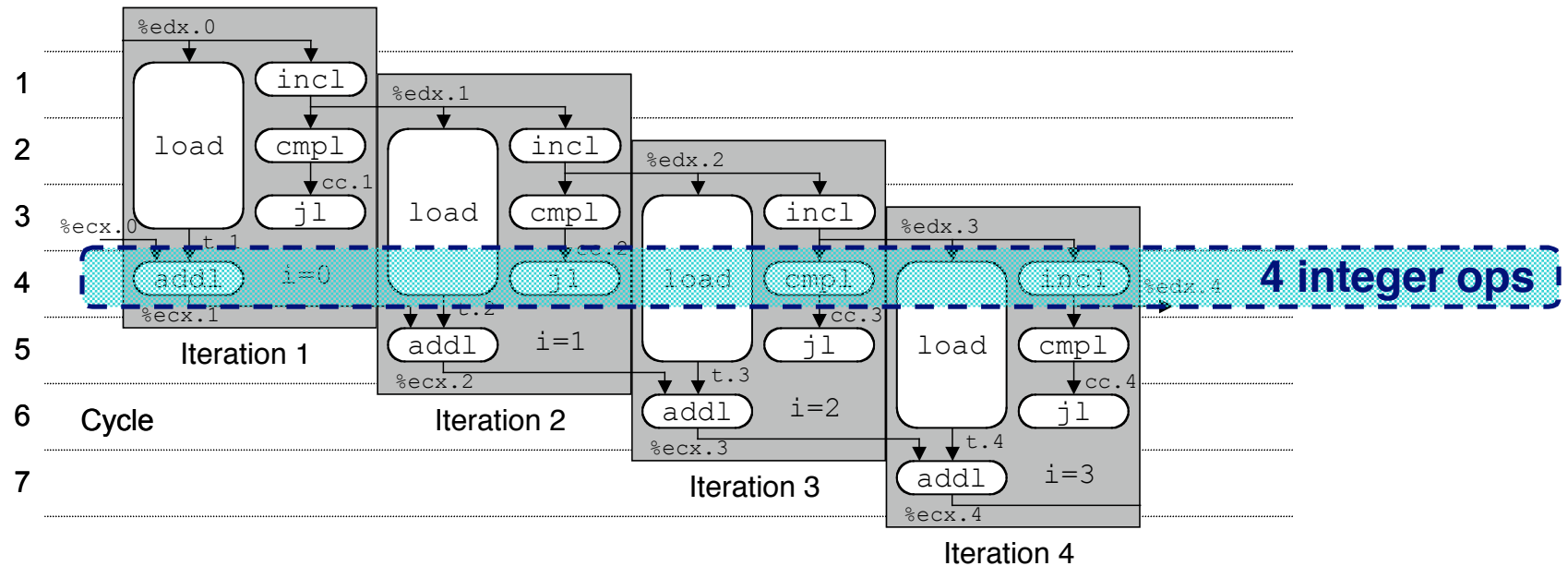

Unlimited Resource Analysis

Performance

- Can begin a new iteration on each clock cycle
- Should give CPE of 1.0
- Would require executing 4 integer operations in parallel

Combining Sum: Resource Constraints

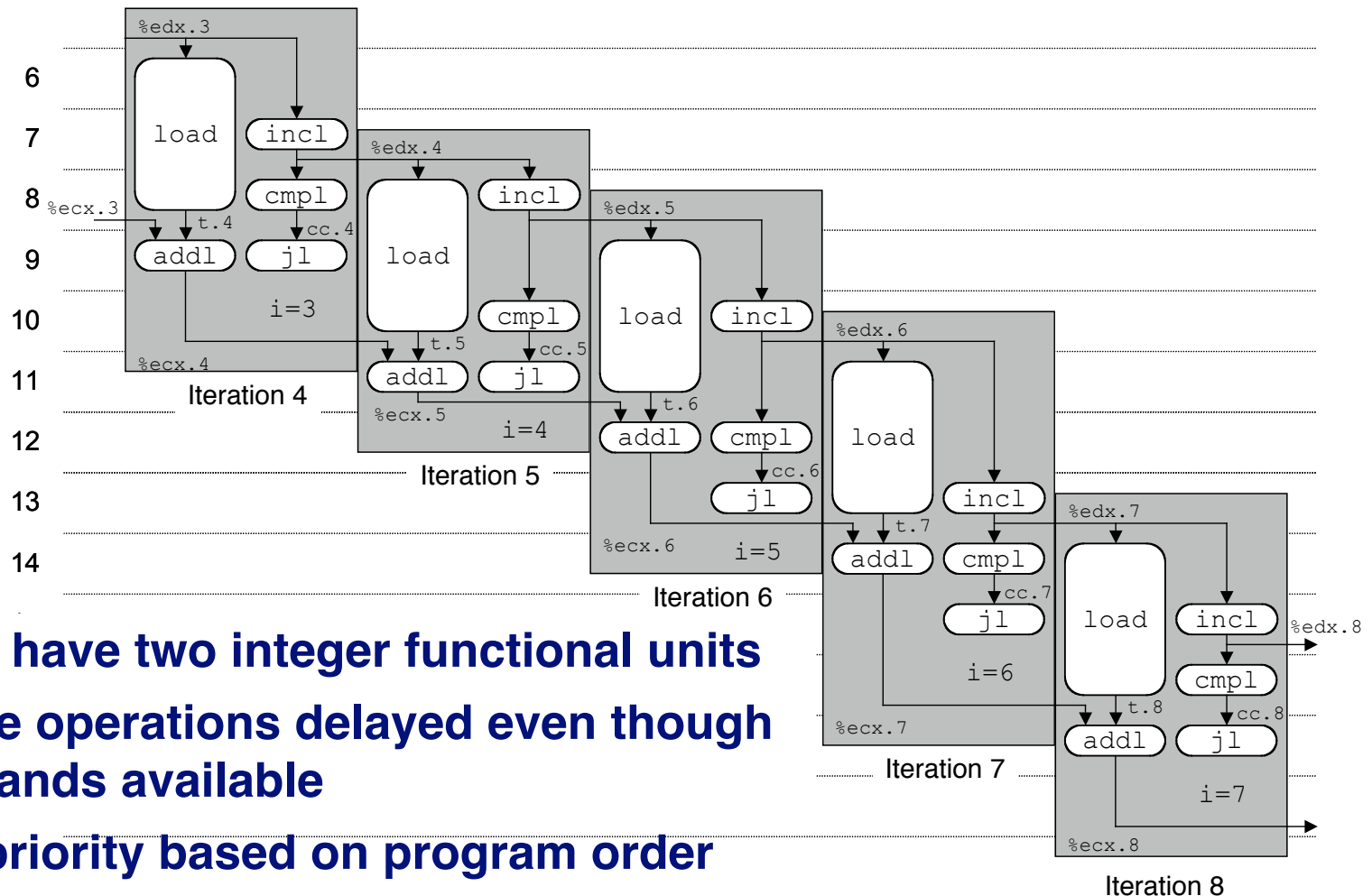

- Only have two integer functional units
- Some operations delayed even though operands available
- Set priority based on program order

Performance

- Sustain CPE of 2.0

Loop Unrolling

```
void combine5(vec_ptr v, int *dest)
{
    int length = vec_length(v);
    int limit = length-2;
    int *data = get_vec_start(v);
    int sum = 0;
    int i;
    /* Combine 3 elements at a time */
    for (i = 0; i < limit; i+=3) {
        sum += data[i] + data[i+2]
            + data[i+1];
    }
    /* Finish any remaining elements */
    for (; i < length; i++) {
        sum += data[i];
    }
    *dest = sum;
}
```

Optimization

- Combine multiple iterations into single loop body
- Amortizes loop overhead across multiple iterations
- Finish extras at end
- Measured CPE = 1.33

Visualizing Unrolled Loop

- Loads can pipeline, since don't have dependencies
- Only one set of loop control operations

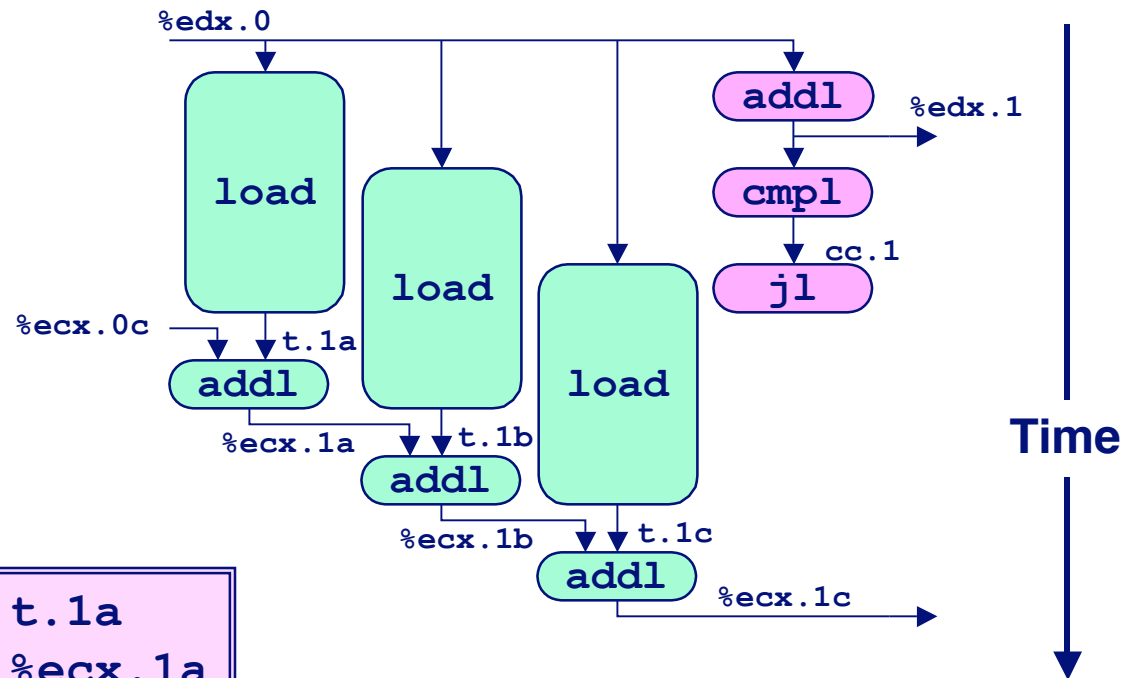

<code>load (%eax,%edx.0,4)</code>	→	<code>t.1a</code>
<code>iaddl t.1a,%ecx.0c</code>	→	<code>%ecx.1a</code>
<code>load 4(%eax,%edx.0,4)</code>	→	<code>t.1b</code>
<code>iaddl t.1b,%ecx.1a</code>	→	<code>%ecx.1b</code>
<code>load 8(%eax,%edx.0,4)</code>	→	<code>t.1c</code>
<code>iaddl t.1c,%ecx.1b</code>	→	<code>%ecx.1c</code>
<code>iaddl \$3,%edx.0</code>	→	<code>%edx.1</code>
<code>cmpl %esi,%edx.1</code>	→	<code>cc.1</code>
<code>jl-taken cc.1</code>		

Executing with Loop Unrolling

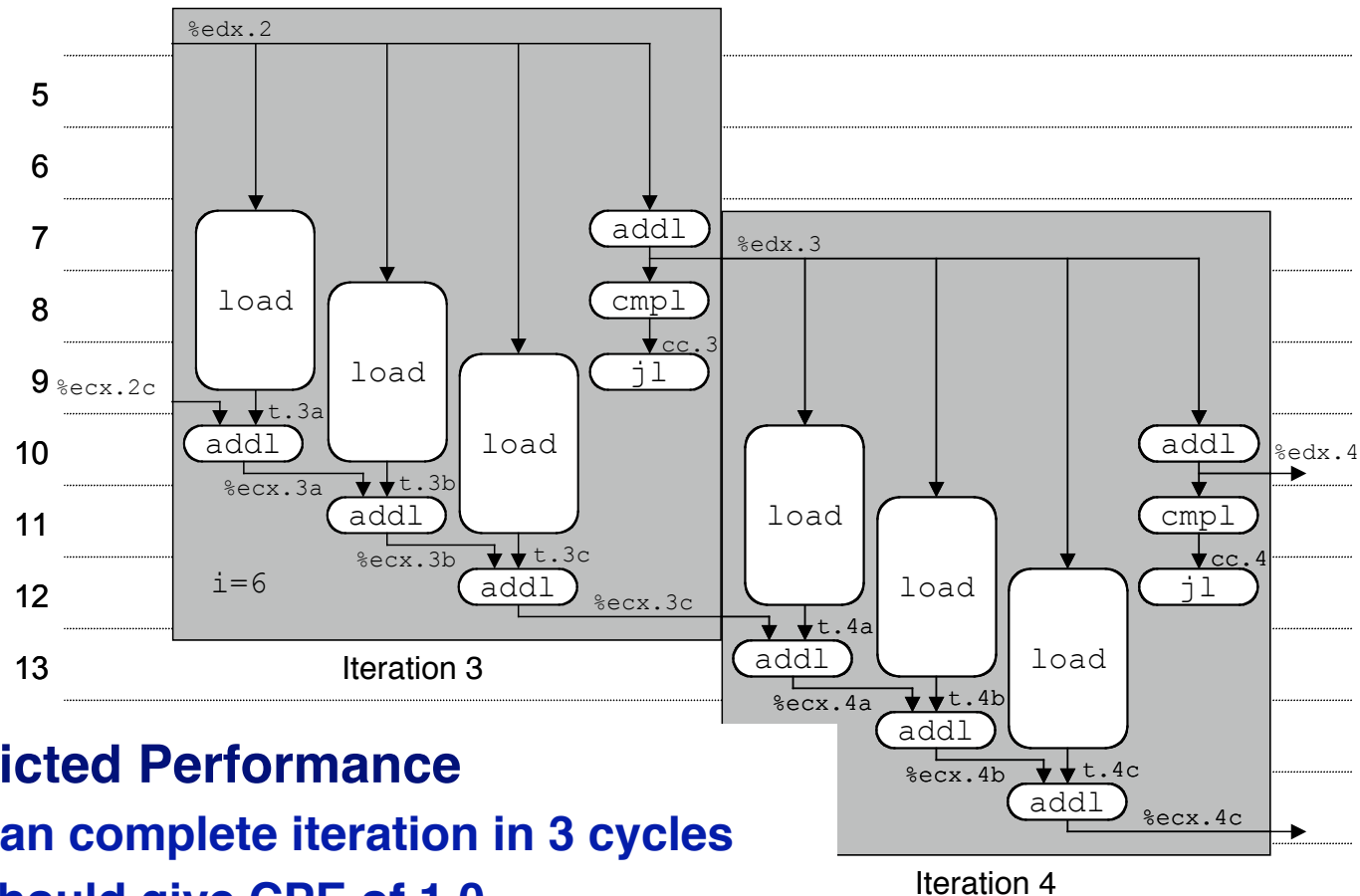

■ Predicted Performance

- Can complete iteration in 3 cycles
- Should give CPE of 1.0

■ Measured Performance

- CPE of 1.33
- One iteration every 4 cycles

Effect of Unrolling

Unrolling Degree		1	2	3	4	8	16
Integer	Sum	2.00	1.50	1.33	1.50	1.25	1.06
Integer	Product	4.00					
FP	Sum	3.00					
FP	Product	5.00					

- Only helps integer sum for our examples
 - Other cases constrained by functional unit latencies
- Effect is nonlinear with degree of unrolling
 - Many subtle effects determine exact scheduling of operations

Serial Computation

Computation

$(((((1 * x_0) * x_1) * x_2) * x_3) * x_4) * x_5) * x_6) * x_7) * x_8) * x_9) * x_{10}) * x_{11})$

Performance

- N elements, D cycles/operation
- N*D cycles

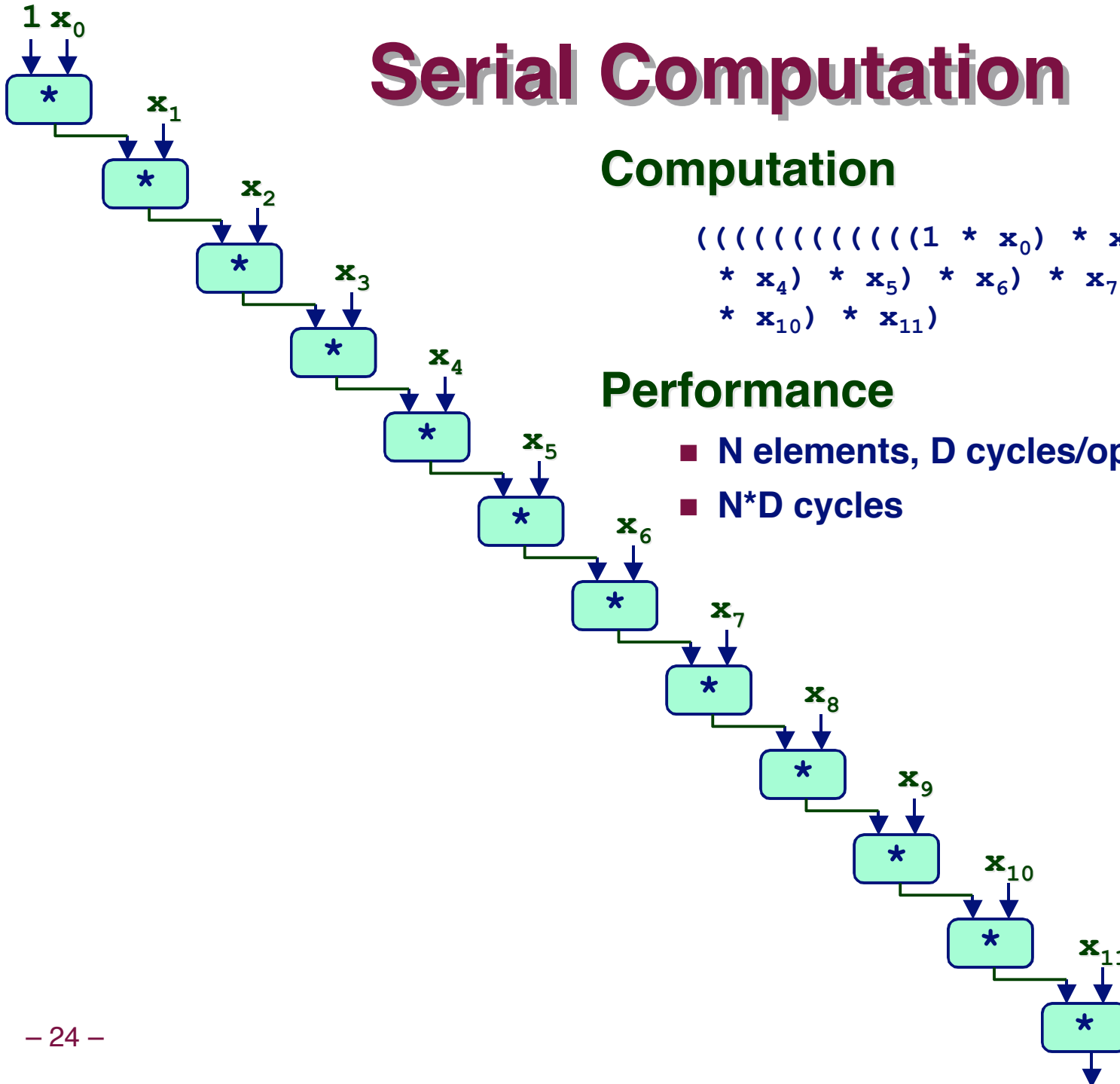

Parallel Loop Unrolling

```
void combine6(vec_ptr v, int *dest)
{
    int length = vec_length(v);
    int limit = length-1;
    int *data = get_vec_start(v);
    int x0 = 1;
    int x1 = 1;
    int i;
    /* Combine 2 elements at a time */
    for (i = 0; i < limit; i+=2) {
        x0 *= data[i];
        x1 *= data[i+1];
    }
    /* Finish any remaining elements */
    for (; i < length; i++) {
        x0 *= data[i];
    }
    *dest = x0 * x1;
}
```

Code Version

- Integer product

Optimization

- Accumulate in two different products
 - Can be performed simultaneously
- Combine at end

Performance

- CPE = 2.0
- 2X performance

Dual Product Computation

Computation

$$\begin{aligned} & ((((((1 * x_0) * x_2) * x_4) * x_6) * x_8) * x_{10}) * \\ & ((((((1 * x_1) * x_3) * x_5) * x_7) * x_9) * x_{11})) \end{aligned}$$

Performance

- N elements, D cycles/operation
- $(N/2+1)*D$ cycles
- $\sim 2X$ performance improvement

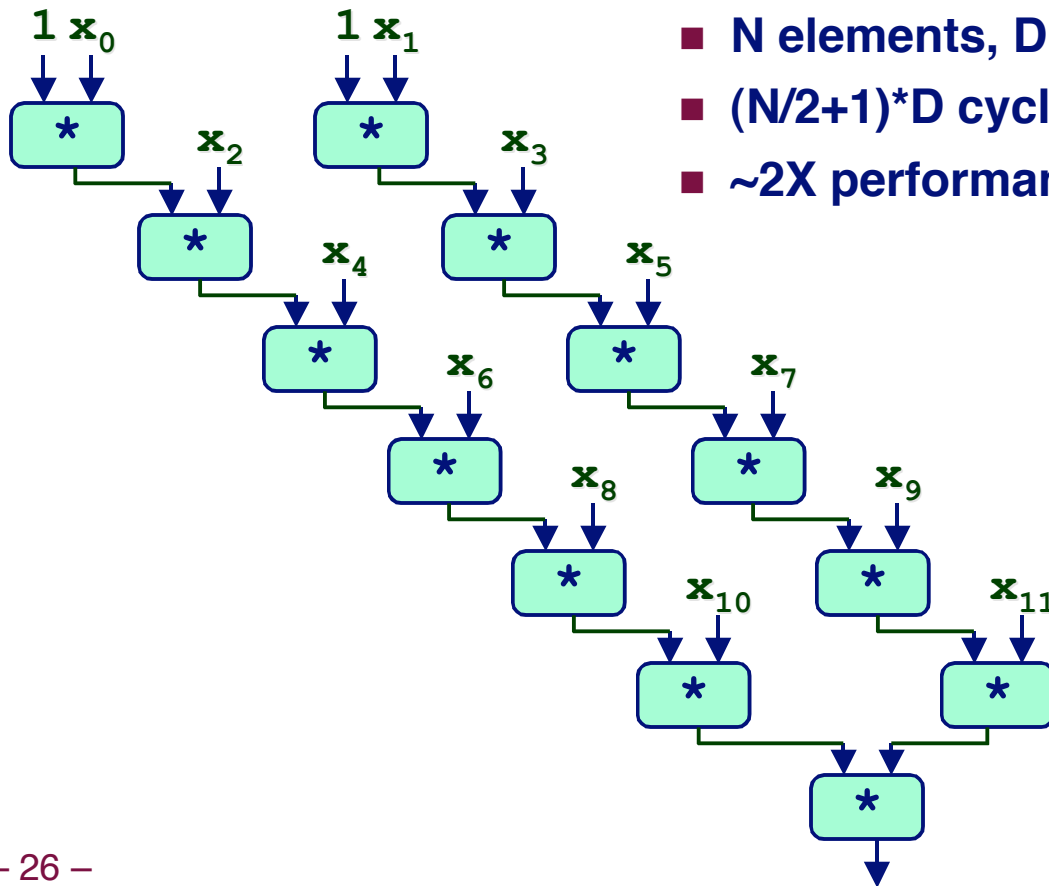

Requirements for Parallel Computation

Mathematical

- Combining operation must be associative & commutative
 - OK for integer multiplication
 - Not strictly true for floating point
 - » OK for most applications

Hardware

- Pipelined functional units
- Ability to dynamically extract parallelism from code

Visualizing Parallel Loop

- Two multiplies within loop no longer have data dependency
- Allows them to pipeline

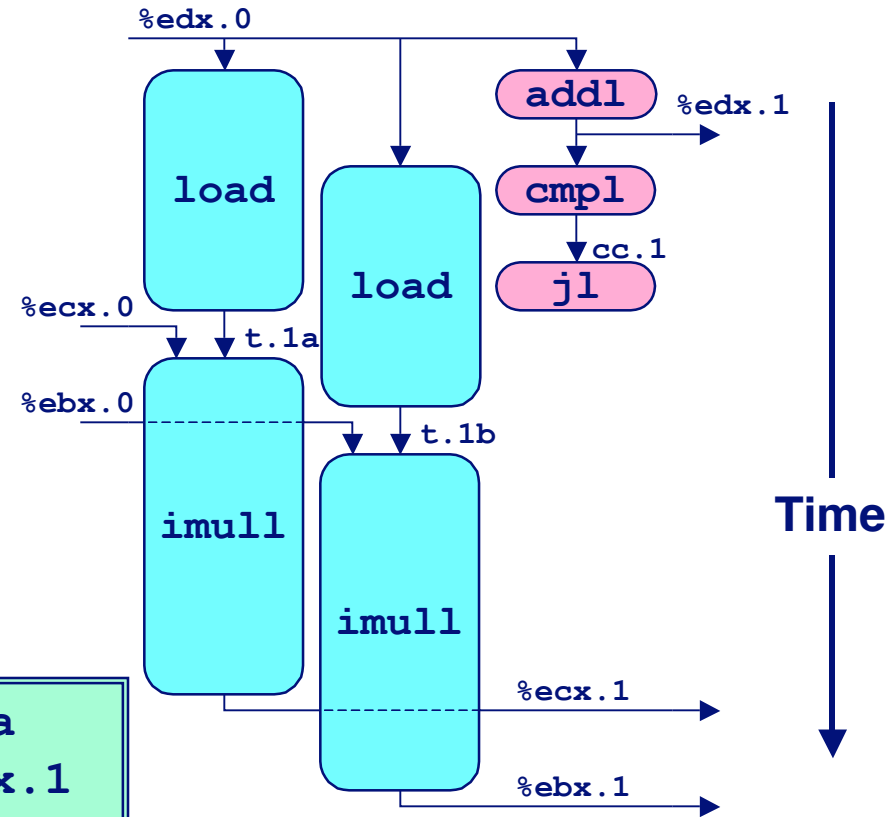

```

load (%eax,%edx.0,4)    → t.1a
imull t.1a, %ecx.0      → %ecx.1
load 4(%eax,%edx.0,4)  → t.1b
imull t.1b, %ebx.0     → %ebx.1
iaddl $2,%edx.0        → %edx.1
cmpl %esi, %edx.1     → cc.1
jl-taken cc.1
    
```

Executing with Parallel Loop

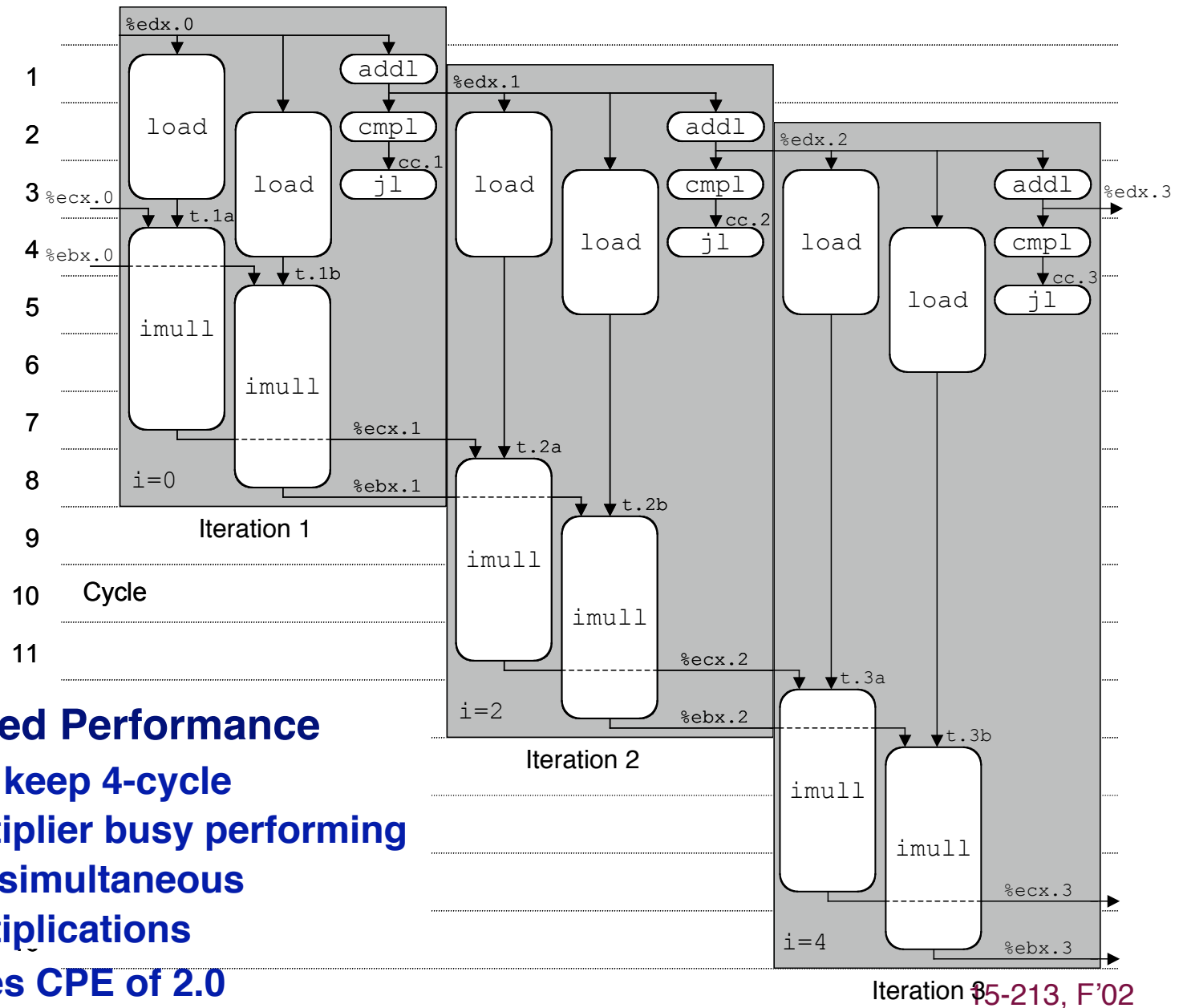

■ Predicted Performance

- Can keep 4-cycle multiplier busy performing two simultaneous multiplications
- Gives CPE of 2.0

Optimization Results for Combining

Method	Integer		Floating Point	
	+	*	+	*
Abstract -g	42.06	41.86	41.44	160.00
Abstract -O2	31.25	33.25	31.25	143.00
Move vec_length	20.66	21.25	21.15	135.00
data access	6.00	9.00	8.00	117.00
Accum. in temp	2.00	4.00	3.00	5.00
Pointer	3.00	4.00	3.00	5.00
Unroll 4	1.50	4.00	3.00	5.00
Unroll 16	1.06	4.00	3.00	5.00
2 X 2	1.50	2.00	2.00	2.50
4 X 4	1.50	2.00	1.50	2.50
8 X 4	1.25	1.25	1.50	2.00
Theoretical Opt.	1.00	1.00	1.00	2.00
<i>Worst : Best</i>	39.7	33.5	27.6	80.0

Parallel Unrolling: Method #2

```
void combine6aa(vec_ptr v, int *dest)
{
    int length = vec_length(v);
    int limit = length-1;
    int *data = get_vec_start(v);
    int x = 1;
    int i;
    /* Combine 2 elements at a time */
    for (i = 0; i < limit; i+=2) {
        x *= (data[i] * data[i+1]);
    }
    /* Finish any remaining elements */
    for (; i < length; i++) {
        x *= data[i];
    }
    *dest = x;
}
```

Code Version

- Integer product

Optimization

- Multiply pairs of elements together
- And then update product
- “Tree height reduction”

Performance

- CPE = 2.5

Method #2 Computation

Computation

$$((((((1 * (x_0 * x_1)) * (x_2 * x_3)) * (x_4 * x_5)) * (x_6 * x_7)) * (x_8 * x_9)) * (x_{10} * x_{11}))$$

Performance

- N elements, D cycles/operation
- Should be $(N/2+1)*D$ cycles
 - CPE = 2.0
- Measured CPE worse

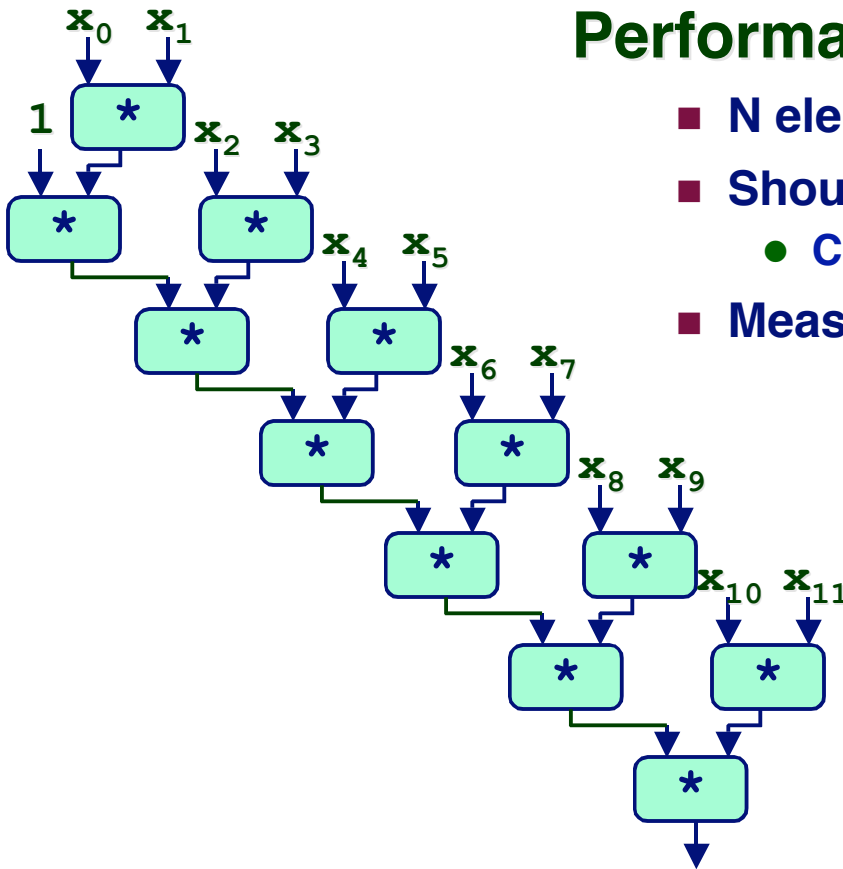

Unrolling	CPE (measured)	CPE (theoretical)
2	2.50	2.00
3	1.67	1.33
4	1.50	1.00
6	1.78	1.00

Understanding Parallelism

```
/* Combine 2 elements at a time */  
for (i = 0; i < limit; i+=2) {  
    x = (x * data[i]) * data[i+1];  
}
```

- CPE = 4.00
- All multiplies performed in sequence

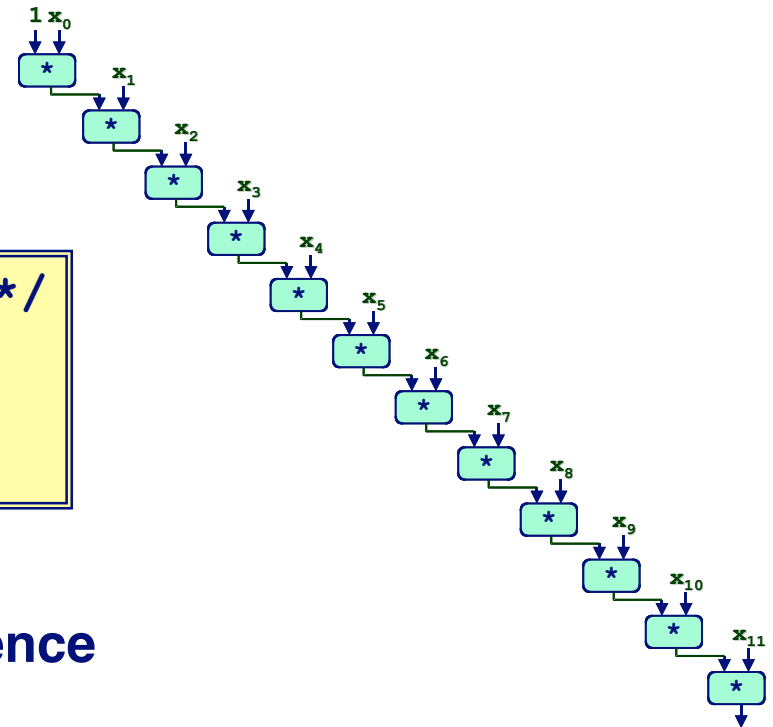

```
/* Combine 2 elements at a time */  
for (i = 0; i < limit; i+=2) {  
    x = x * (data[i] * data[i+1]);  
}
```

- CPE = 2.50
- Multiplies overlap

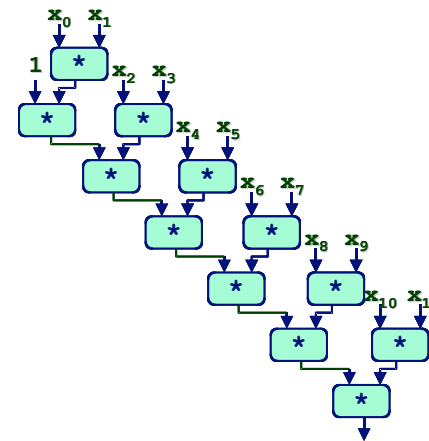

Limitations of Parallel Execution

Need Lots of Registers

- To hold sums/products
- Only 6 usable integer registers
 - Also needed for pointers, loop conditions
- 8 FP registers
- When not enough registers, must spill temporaries onto stack
 - Wipes out any performance gains
- Not helped by renaming
 - Cannot reference more operands than instruction set allows
 - Major drawback of IA32 instruction set

Register Spilling Example

Example

- 8 X 8 integer product
- 7 local variables share 1 register
- See that are storing locals on stack
- E.g., at -8 (%ebp)

```
.L165:  
    imull (%eax),%ecx  
    movl -4(%ebp),%edi  
    imull 4(%eax),%edi  
    movl %edi,-4(%ebp)  
    movl -8(%ebp),%edi  
    imull 8(%eax),%edi  
    movl %edi,-8(%ebp)  
    movl -12(%ebp),%edi  
    imull 12(%eax),%edi  
    movl %edi,-12(%ebp)  
    movl -16(%ebp),%edi  
    imull 16(%eax),%edi  
    movl %edi,-16(%ebp)  
  
    ...  
    addl $32,%eax  
    addl $8,%edx  
    cmpl -32(%ebp),%edx  
    jl .L165
```

Summary: Results for Pentium III

Method	Integer		Floating Point	
	+	*	+	*
Abstract -g	42.06	41.86	41.44	160.00
Abstract -O2	31.25	33.25	31.25	143.00
Move vec_length	20.66	21.25	21.15	135.00
data access	6.00	9.00	8.00	117.00
Accum. in temp	2.00	4.00	3.00	5.00
Unroll 4	1.50	4.00	3.00	5.00
Unroll 16	1.06	4.00	3.00	5.00
4 X 2	1.50	2.00	1.50	2.50
8 X 4	1.25	1.25	1.50	2.00
8 X 8	1.88	1.88	1.75	2.00
Worst : Best	39.7	33.5	27.6	80.0

- Biggest gain doing basic optimizations
- But, last little bit helps

Results for Alpha Processor

Method	Integer		Floating Point	
	+	*	+	*
Abstract -g	40.14	47.14	52.07	53.71
Abstract -O2	25.08	36.05	37.37	32.02
Move vec_length	19.19	32.18	28.73	32.73
data access	6.26	12.52	13.26	13.01
Accum. in temp	1.76	9.01	8.08	8.01
Unroll 4	1.51	9.01	6.32	6.32
Unroll 16	1.25	9.01	6.33	6.22
4 X 2	1.19	4.69	4.44	4.45
8 X 4	1.15	4.12	2.34	2.01
8 X 8	1.11	4.24	2.36	2.08
<i>Worst : Best</i>	36.2	11.4	22.3	26.7

- Overall trends very similar to those for Pentium III.
- Even though very different architecture and compiler

Results for Pentium 4

Method	Integer		Floating Point	
	+	*	+	*
Abstract -g	35.25	35.34	35.85	38.00
Abstract -O2	26.52	30.26	31.55	32.00
Move vec_length	18.00	25.71	23.36	24.25
data access	3.39	31.56	27.50	28.35
Accum. in temp	2.00	14.00	5.00	7.00
Unroll 4	1.01	14.00	5.00	7.00
Unroll 16	1.00	14.00	5.00	7.00
4 X 2	1.02	7.00	2.63	3.50
8 X 4	1.01	3.98	1.82	2.00
8 X 8	1.63	4.50	2.42	2.31
<i>Worst : Best</i>	<i>35.2</i>	<i>8.9</i>	<i>19.7</i>	<i>19.0</i>

- Higher latencies (int * = 14, fp + = 5.0, fp * = 7.0)
 - Clock runs at 2.0 GHz
 - Not an improvement over 1.0 GHz P3 for integer *
- Avoids FP multiplication anomaly

What About Branches?

Challenge

- Instruction Control Unit must work well ahead of Exec. Unit
 - To generate enough operations to keep EU busy

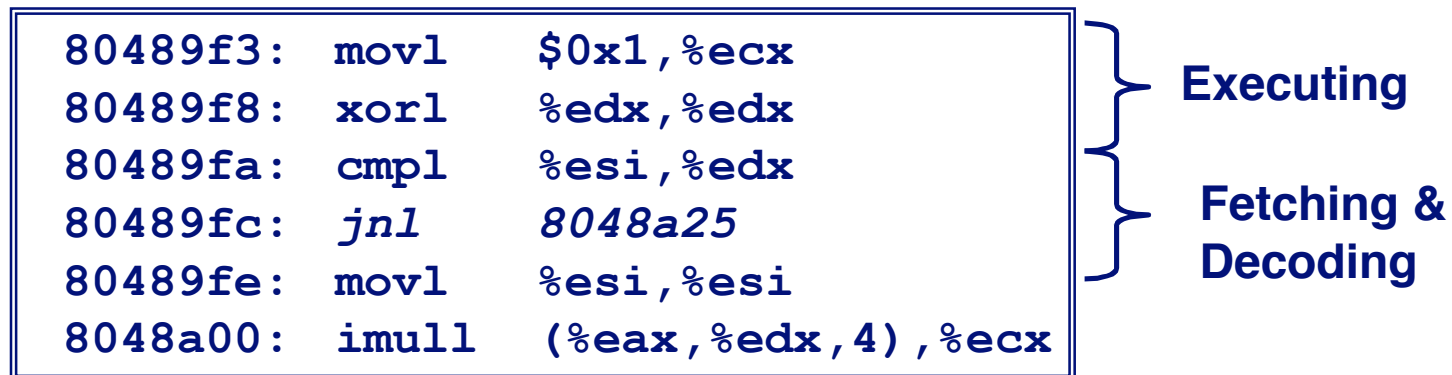

- When encounters conditional branch, cannot reliably determine where to continue fetching

Branch Outcomes

- When encounter conditional branch, cannot determine where to continue fetching
 - Branch Taken: Transfer control to branch target
 - Branch Not-Taken: Continue with next instruction in sequence
- Cannot resolve until outcome determined by branch/integer unit

```
80489f3: movl    $0x1,%ecx
80489f8: xorl    %edx,%edx
80489fa: cmpl    %esi,%edx
80489fc: jnl     8048a25
80489fe: movl    %esi,%esi
8048a00: imull   (%eax,%edx,4),%ecx
```

Branch Not-Taken

```
8048a25: cmpl    %edi,%edx
8048a27: jl      8048a20
8048a29: movl    0xc(%ebp),%eax
8048a2c: leal   0xffffffe8(%ebp),%esp
8048a2f: movl    %ecx,(%eax)
```

Branch Taken

Branch Prediction

Idea

- Guess which way branch will go
- Begin executing instructions at predicted position
 - But don't actually modify register or memory data

```
80489f3:  movl    $0x1,%ecx
80489f8:  xorl    %edx,%edx
80489fa:  cmpl    %esi,%edx
80489fc:  jnl     8048a25
. . .
```

Predict Taken

```
8048a25:  cmpl    %edi,%edx
8048a27:  jl     8048a20
8048a29:  movl    0xc(%ebp),%eax
8048a2c:  leal   0xffffffe8(%ebp),%esp
8048a2f:  movl    %ecx,(%eax)
```

Execute

Branch Prediction Through Loop

```
80488b1:  movl    (%ecx,%edx,4),%eax
80488b4:  addl    %eax,(%edi)
80488b6:  incl    %edx
80488b7:  cmpl   %esi,%edx
80488b9:  jl     80488b1
```

i = 98

Assume vector length = 100

Predict Taken (OK)

```
80488b1:  movl    (%ecx,%edx,4),%eax
80488b4:  addl    %eax,(%edi)
80488b6:  incl    %edx
80488b7:  cmpl   %esi,%edx
80488b9:  jl     80488b1
```

i = 99

Predict Taken (Oops)

```
80488b1:  movl    (%ecx,%edx,4),%eax
80488b4:  addl    %eax,(%edi)
80488b6:  incl    %edx
80488b7:  cmpl   %esi,%edx
80488b9:  jl     80488b1
```

i = 100

Read invalid location

```
80488b1:  movl    (%ecx,%edx,4),%eax
80488b4:  addl    %eax,(%edi)
80488b6:  incl    %edx
80488b7:  cmpl   %esi,%edx
80488b9:  jl     80488b1
```

i = 101



Branch Misprediction Invalidation

```
80488b1:  movl    (%ecx,%edx,4),%eax
80488b4:  addl    %eax,(%edi)
80488b6:  incl   %edx
80488b7:  cmpl   %esi,%edx
80488b9:  jl     80488b1
```

Assume vector length = 100

i = 98

Predict Taken (OK)

```
80488b1:  movl    (%ecx,%edx,4),%eax
80488b4:  addl    %eax,(%edi)
80488b6:  incl   %edx
80488b7:  cmpl   %esi,%edx
80488b9:  jl     80488b1
```

i = 99

Predict Taken (Oops)

```
80488b1:  movl    (%ecx,%edx,4),%eax
80488b4:  addl    %eax,(%edi)
80488b6:  incl   %edx
80488b7:  cmpl   %esi,%edx
80488b9:  jl     80488b1
```

~~*i = 100*~~

Invalidate

```
80488b1:  movl    (%ecx,%edx,4),%eax
80488b4:  addl    %eax,(%edi)
80488b6:  incl   %edx
```

~~*i = 101*~~

Branch Misprediction Recovery

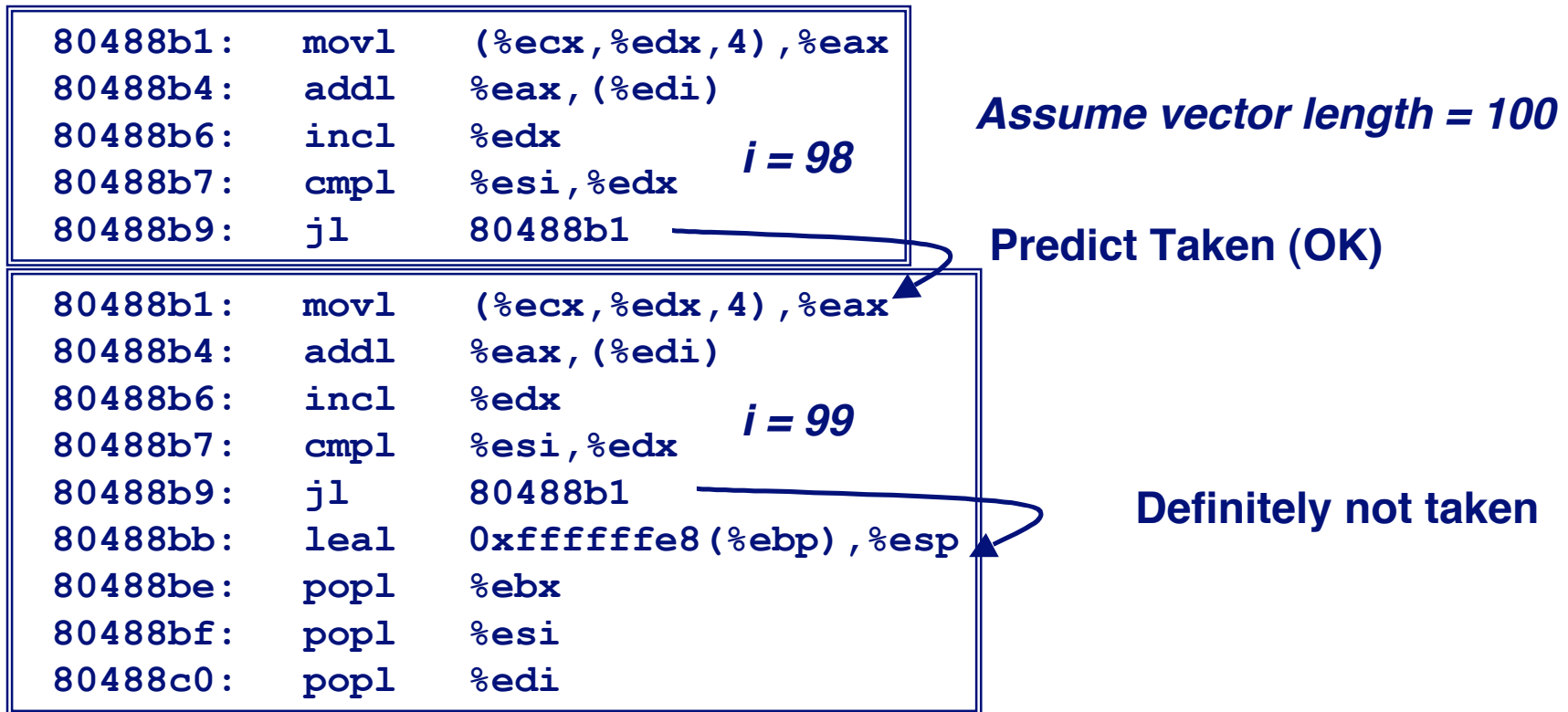

Performance Cost

- Misprediction on Pentium III wastes ~14 clock cycles
- That's a lot of time on a high performance processor

Avoiding Branches

On Modern Processor, Branches Very Expensive

- Unless prediction can be reliable
- When possible, best to avoid altogether

Example

- Compute maximum of two values
 - 14 cycles when prediction correct
 - 29 cycles when incorrect

```
int max(int x, int y)
{
    return (x < y) ? y : x;
}
```

```
movl 12(%ebp),%edx # Get y
movl 8(%ebp),%eax  # rval=x
cmpl %edx,%eax    # rval:y
jge L11           # skip when >=
movl %edx,%eax    # rval=y
L11:
```

Avoiding Branches with Bit Tricks

- In style of Lab #1
- Use masking rather than conditionals

```
int bmax(int x, int y)
{
    int mask = -(x>y);
    return (mask & x) | (~mask & y);
}
```

- Compiler still uses conditional
 - 16 cycles when predict correctly
 - 32 cycles when mispredict

```
xorl %edx,%edx      # mask = 0
movl 8(%ebp),%eax
movl 12(%ebp),%ecx
cmpl %ecx,%eax
jle L13             # skip if x<=y
movl $-1,%edx      # mask = -1
L13:
```

Avoiding Branches with Bit Tricks

- Force compiler to generate desired code

```
int bvmax(int x, int y)
{
    volatile int t = (x>y);
    int mask = -t;
    return (mask & x) |
           (~mask & y);
}
```

```
movl 8(%ebp),%ecx    # Get x
movl 12(%ebp),%edx   # Get y
cmpl %edx,%ecx      # x:y
setg %al            # (x>y)
movzbl %al,%eax     # Zero extend
movl %eax,-4(%ebp)  # Save as t
movl -4(%ebp),%eax  # Retrieve t
```

- `volatile` declaration forces value to be written to memory
 - Compiler must therefore generate code to compute `t`
 - Simplest way is `setg/movzbl` combination
- Not very elegant!
 - A hack to get control over compiler
- 22 clock cycles on all data
 - Better than misprediction

Conditional Move

- Added with P6 microarchitecture (PentiumPro onward)
- `cmovXXl %edx, %eax`
 - If condition `xx` holds, copy `%edx` to `%eax`
 - Doesn't involve any branching
 - Handled as operation within Execution Unit

```
movl 8(%ebp), %edx    # Get x
movl 12(%ebp), %eax   # rval=y
cmpl %edx, %eax       # rval:x
cmovll %edx, %eax     # If <, rval=x
```

- Current version of GCC won't use this instruction
 - Thinks it's compiling for a 386
- Performance
 - 14 cycles on all data

Machine-Dependent Opt. Summary

Pointer Code

- Look carefully at generated code to see whether helpful

Loop Unrolling

- Some compilers do this automatically
- Generally not as clever as what can achieve by hand

Exposing Instruction-Level Parallelism

- Very machine dependent

Warning:

- Benefits depend heavily on particular machine
- Best if performed by compiler
 - But GCC on IA32/Linux is not very good
- Do only for performance-critical parts of code

Role of Programmer

How should I write my programs, given that I have a good, optimizing compiler?

Don't: Smash Code into Oblivion

- Hard to read, maintain, & assure correctness

Do:

- Select best algorithm
- Write code that's readable & maintainable
 - Procedures, recursion, without built-in constant limits
 - Even though these factors can slow down code
- Eliminate optimization blockers
 - Allows compiler to do its job

Focus on Inner Loops

- Do detailed optimizations where code will be executed repeatedly
- Will get most performance gain here