

CS:APP Chapter 4
Computer Architecture
Pipelined
Implementation
Part II

Randal E. Bryant

Carnegie Mellon University

<http://csapp.cs.cmu.edu>

Overview

Make the pipelined processor work!

Data Hazards

- Instruction having register R as source follows shortly after instruction having register R as destination
- Common condition, don't want to slow down pipeline

Control Hazards

- Mispredict conditional branch
 - Our design predicts all branches as being taken
 - Naïve pipeline executes two extra instructions
- Getting return address for `ret` instruction
 - Naïve pipeline executes three extra instructions

Making Sure It Really Works

- What if multiple special cases happen simultaneously?

Pipeline Stages

Fetch

- Select current PC
- Read instruction
- Compute incremented PC

Decode

- Read program registers

Execute

- Operate ALU

Memory

- Read or write data memory

Write Back

- Update register file

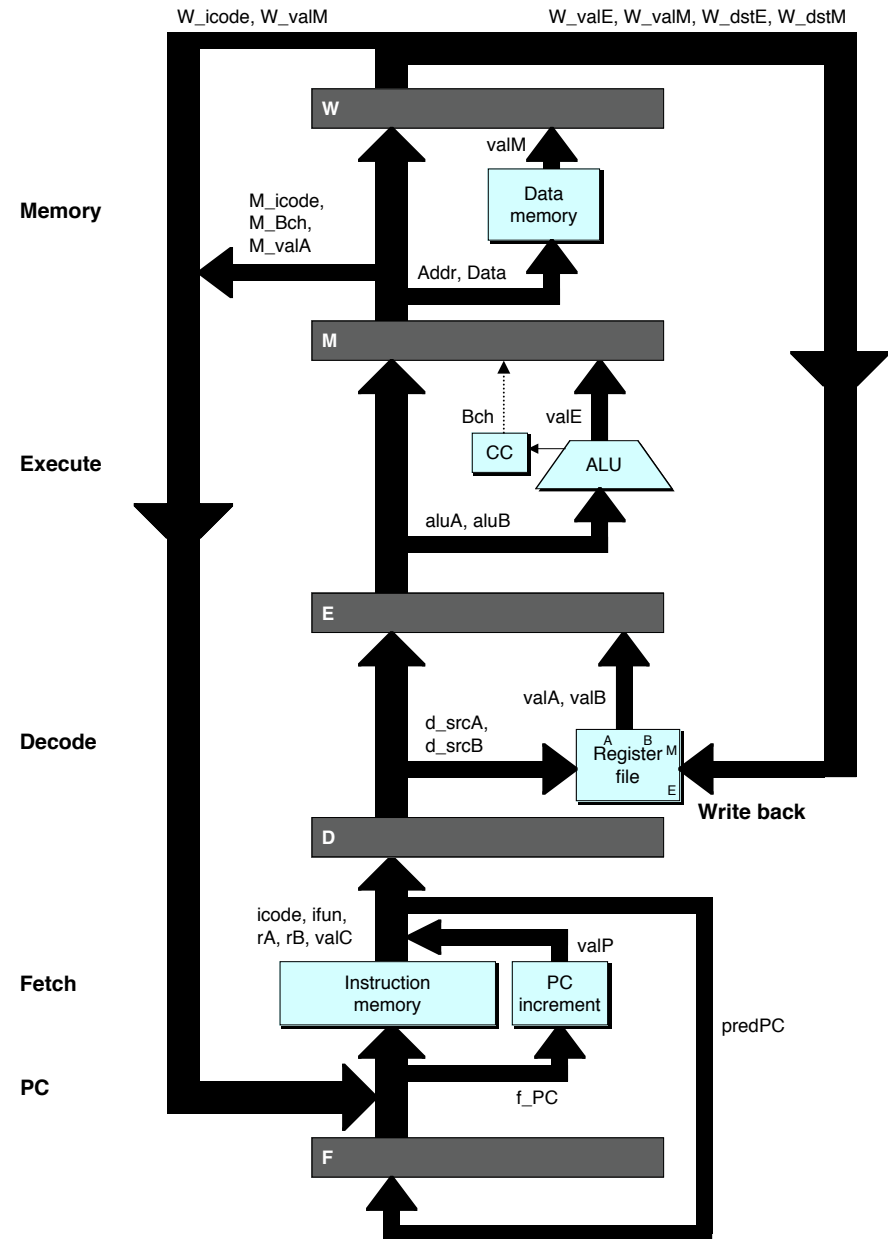

PIPE- Hardware

- Pipeline registers hold intermediate values from instruction execution

Forward (Upward) Paths

- Values passed from one stage to next
- Cannot jump past stages
 - e.g., valC passes through decode

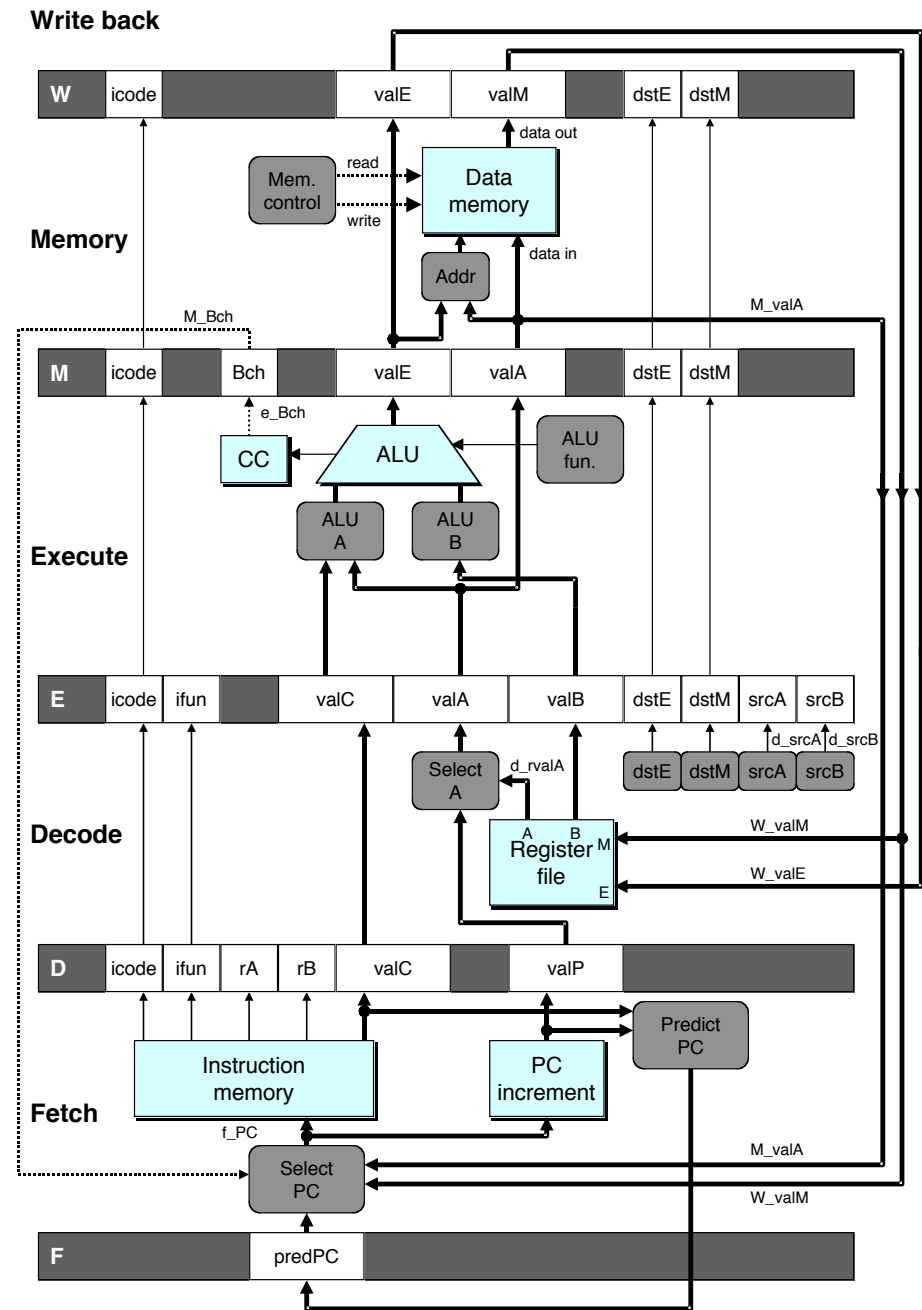

Data Dependencies: 2 Nop's

```
# demo-h2.y
```

```
0x000: irmovl $10,%edx
```

```
0x006: irmovl $3,%eax
```

```
0x00c: nop
```

```
0x00d: nop
```

```
0x00e: addl %edx,%eax
```

```
0x010: halt
```

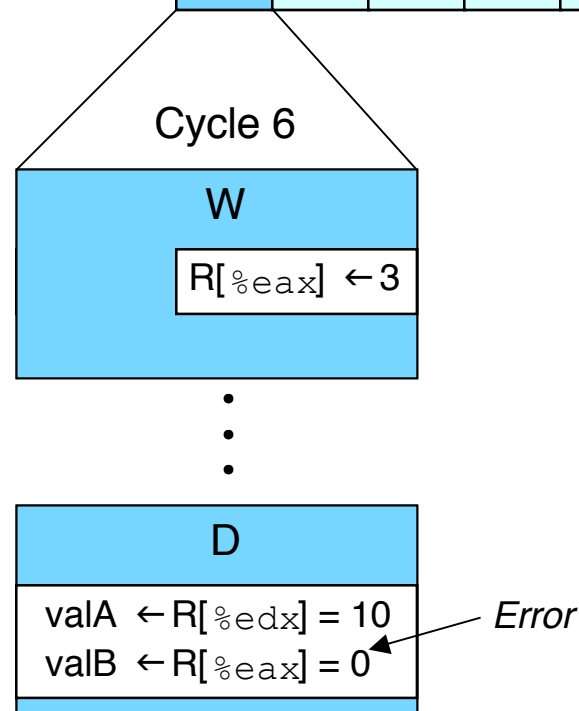
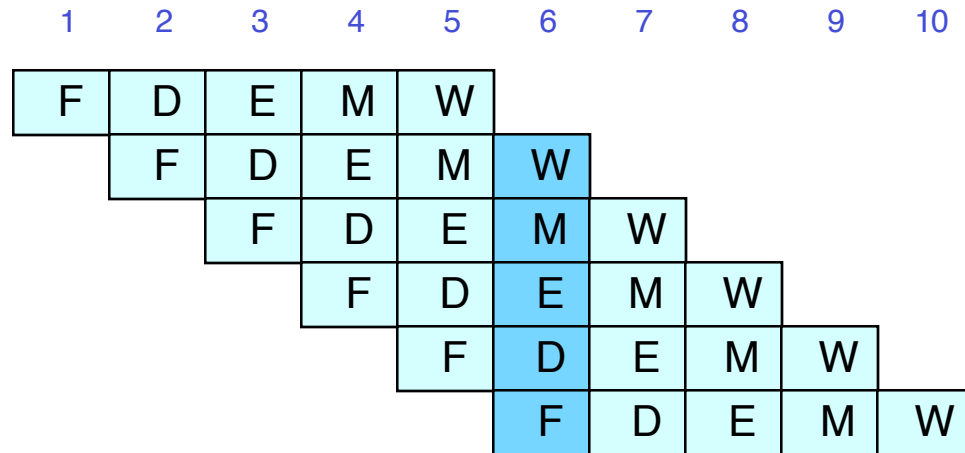

Data Dependencies: No Nop

```
# demo-h0.y
0x000: irmovl $10,%edx
0x006: irmovl $3,%eax
0x00c: addl %edx,%eax
0x00e: halt
```

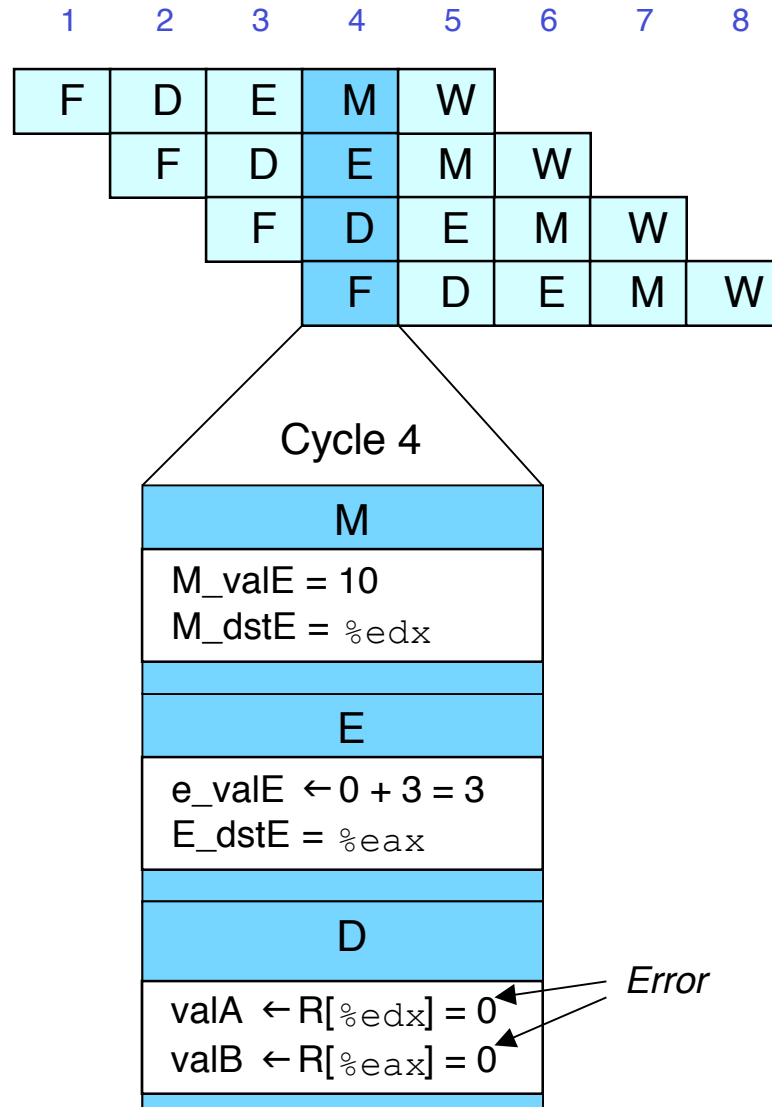

Stalling for Data Dependencies

```
# demo-h2.y
```

```
0x000: irmovl $10,%edx
```

```
0x006: irmovl $3,%eax
```

```
0x00c: nop
```

```
0x00d: nop
```

bubble

```
0x00e: addl %edx,%eax
```

```
0x010: halt
```

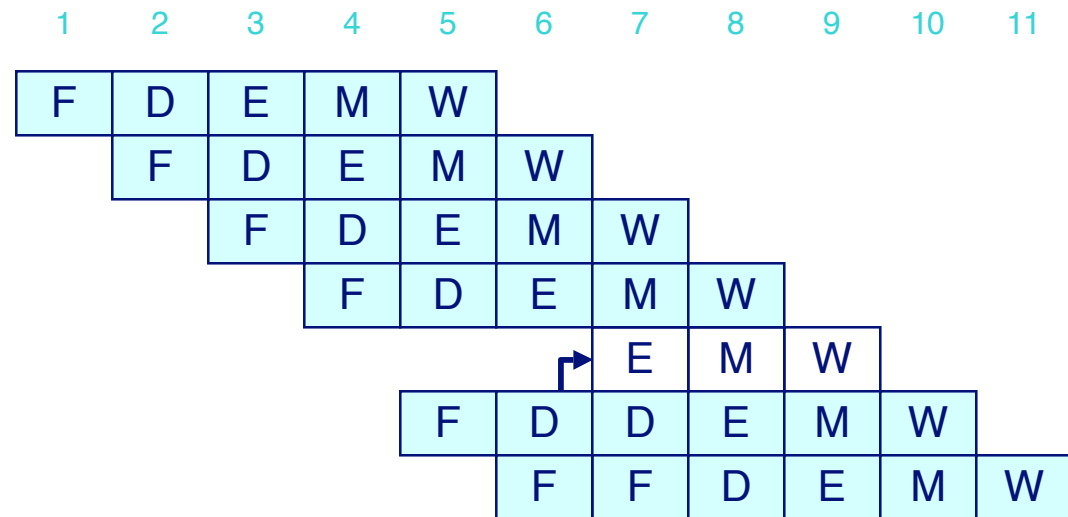

- If instruction follows too closely after one that writes register, slow it down
- Hold instruction in decode
- Dynamically inject nop into execute stage

Stall Condition

Source Registers

- srcA and srcB of current instruction in decode stage

Destination Registers

- dstE and dstM fields
- Instructions in execute, memory, and write-back stages

Special Case

- Don't stall for register ID 8
 - Indicates absence of register operand

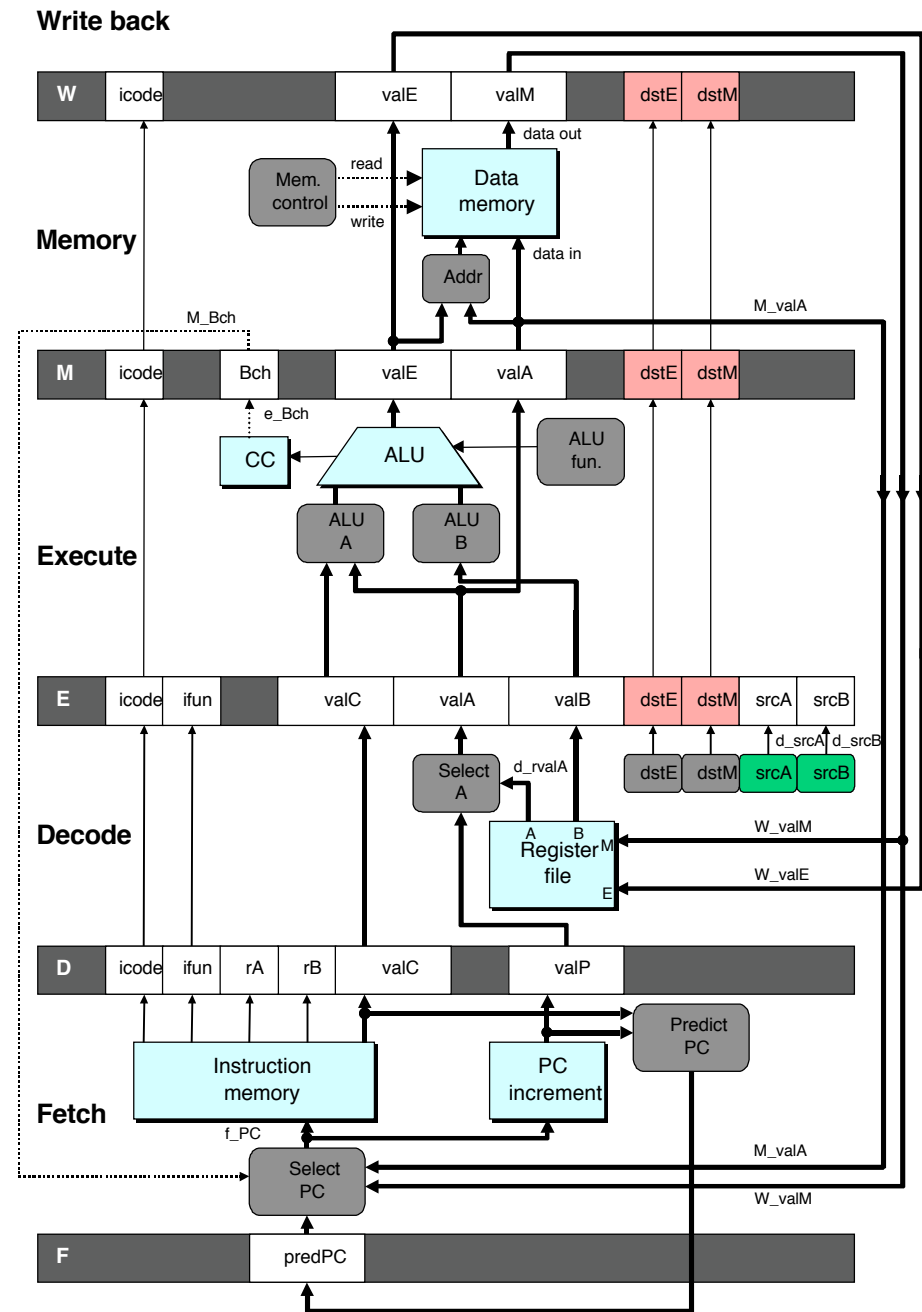

Detecting Stall Condition

```
# demo-h2.y
```

```
0x000: irmovl $10,%edx
```

```
0x006: irmovl $3,%eax
```

```
0x00c: nop
```

```
0x00d: nop
```

bubble

```
0x00e: addl %edx,%eax
```

```
0x010: halt
```

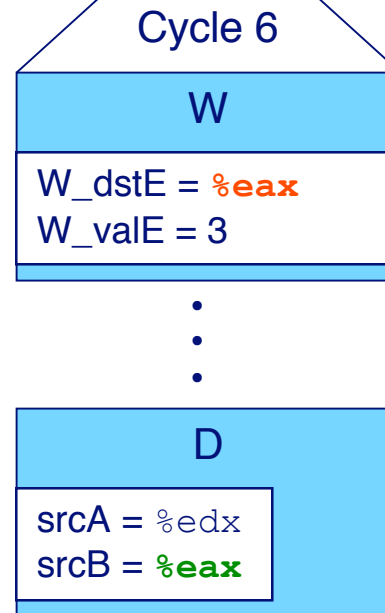
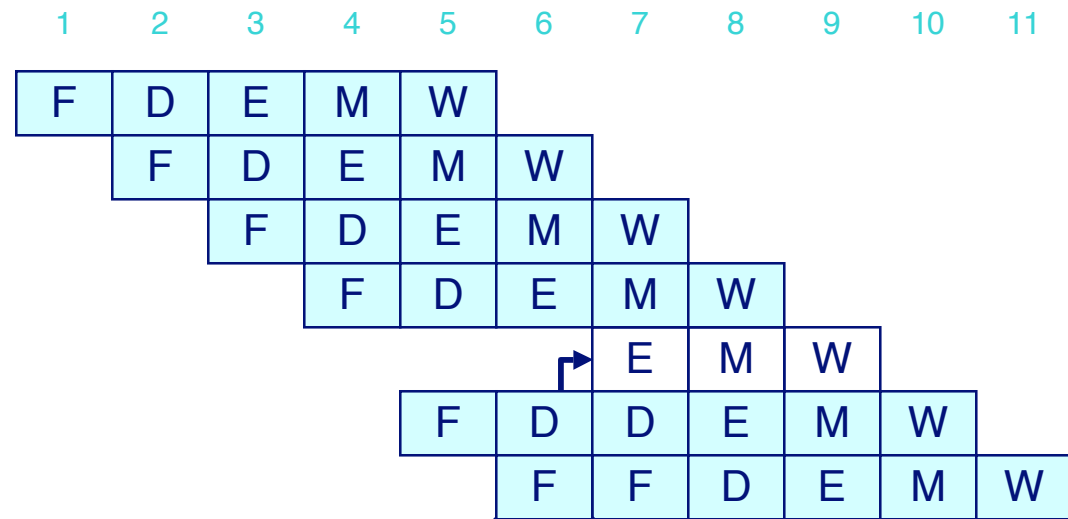

Stalling X3

```
# demo-h0.y
0x000: irmovl $10,%edx
0x006: irmovl $3,%eax
      bubble
      bubble
      bubble
0x00c: addl %edx,%eax
0x00e: halt
```

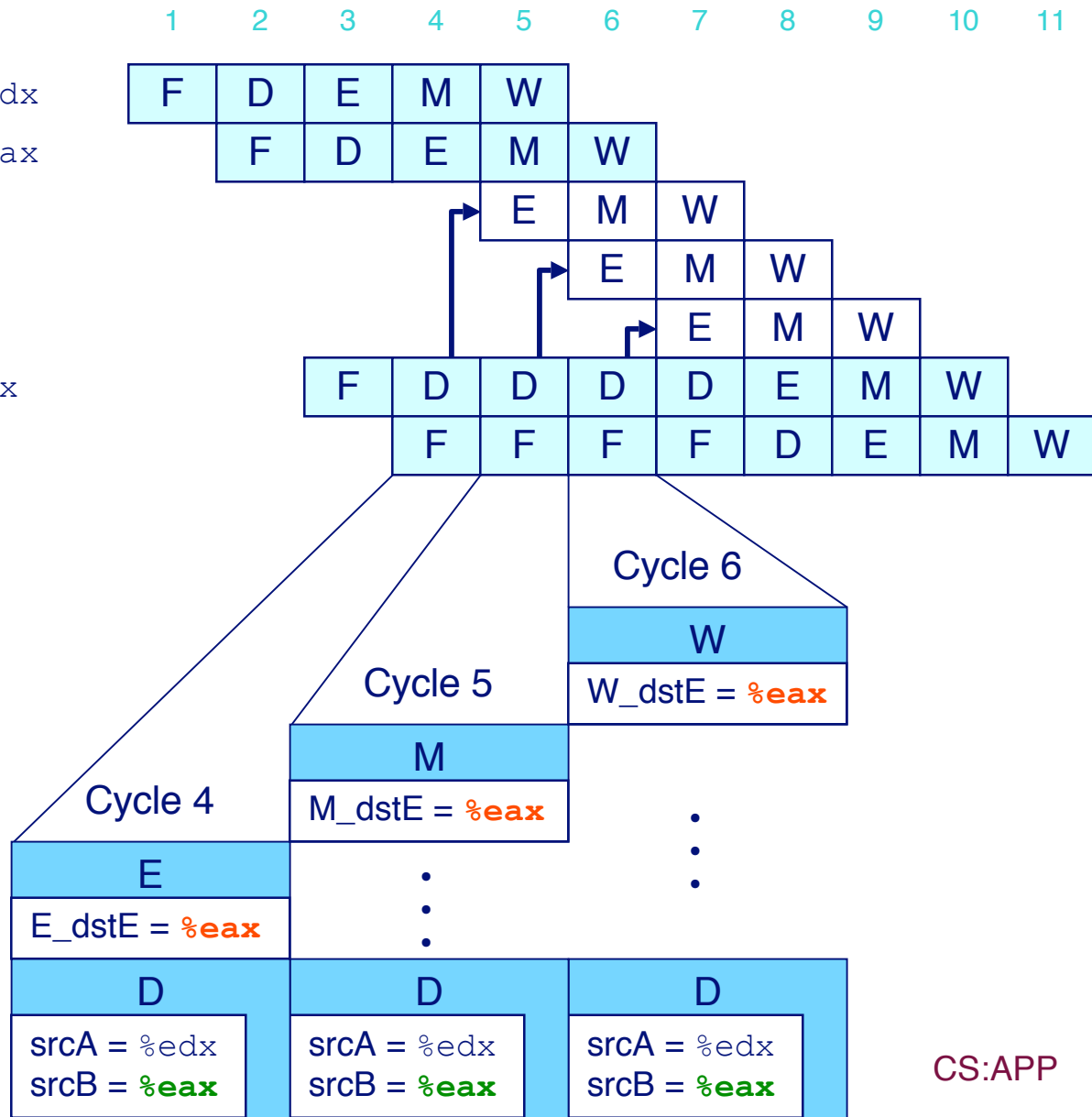

What Happens When Stalling?

```
# demo-h0.ys
0x000: irmovl $10,%edx
0x006: irmovl $3,%eax
0x00c: addl %edx,%eax
0x00e: halt
```

Cycle 8	
Write Back	<i>bubble</i>
Memory	<i>bubble</i>
Execute	0x00c: addl %edx,%eax
Decode	0x00e: halt
Fetch	

- **Stalling instruction held back in decode stage**
- **Following instruction stays in fetch stage**
- **Bubbles injected into execute stage**
 - Like dynamically generated nop's
 - Move through later stages

Implementing Stalling

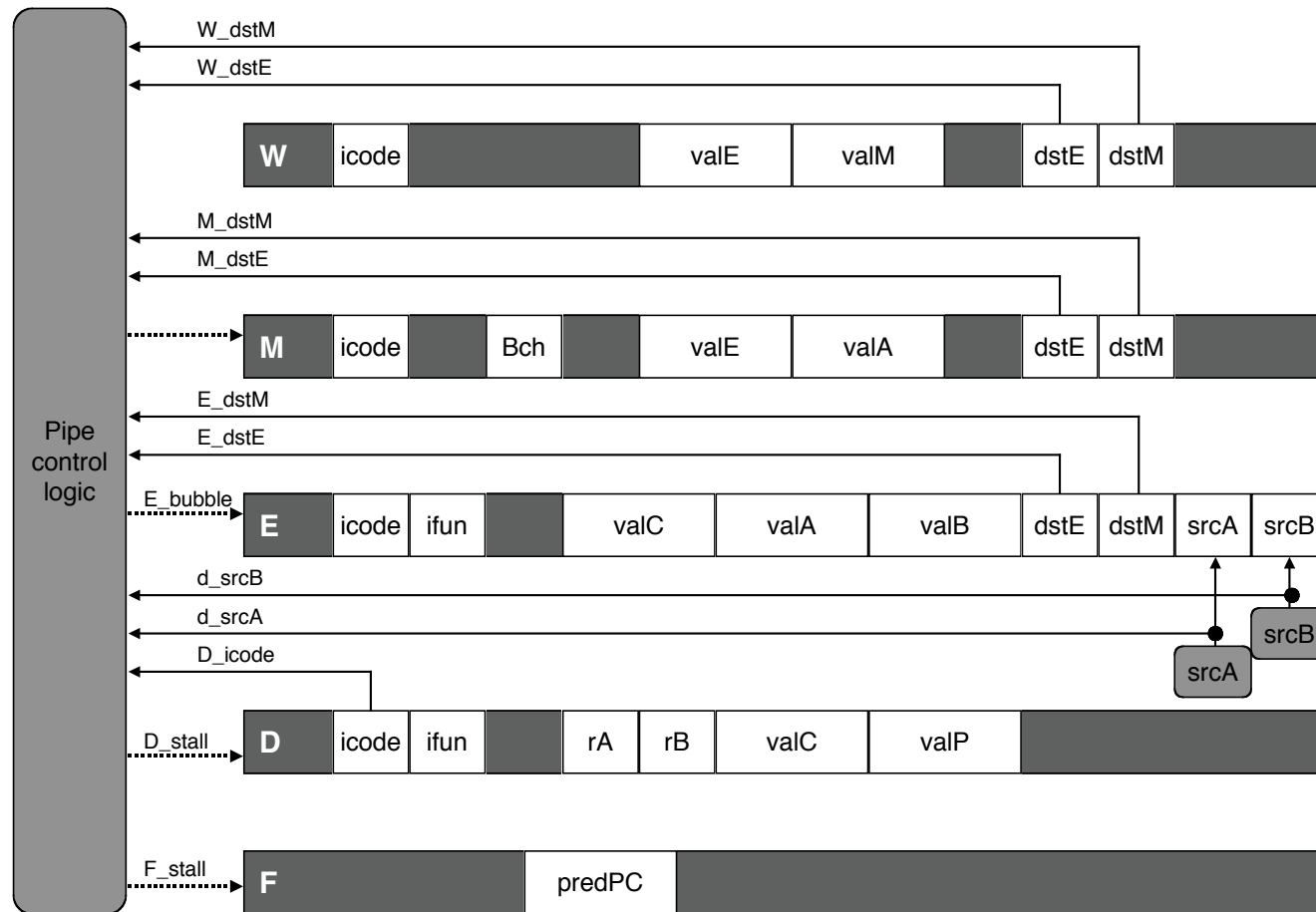

Pipeline Control

- Combinational logic detects stall condition
- Sets mode signals for how pipeline registers should update

Pipeline Register Modes

Normal

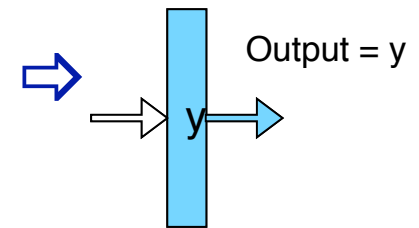
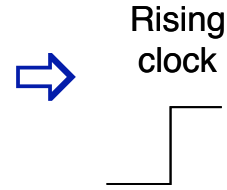
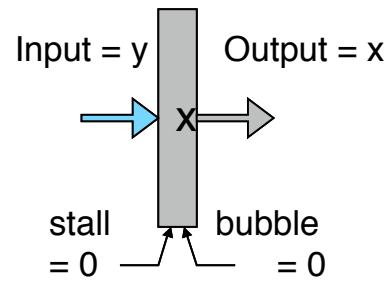

Stall

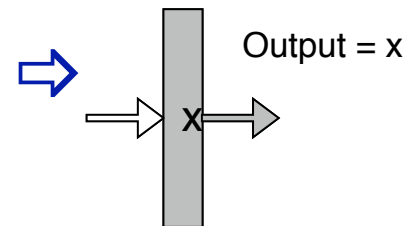
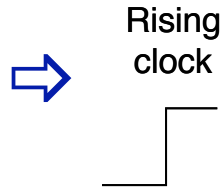
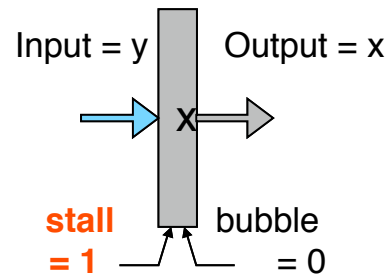

Bubble

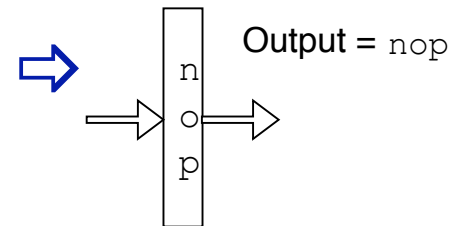
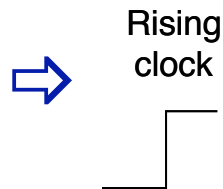
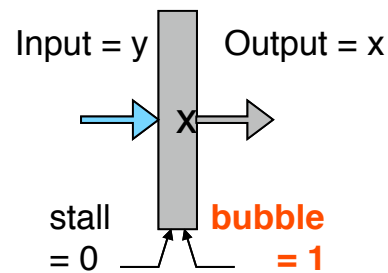

Data Forwarding

Naïve Pipeline

- Register isn't written until completion of write-back stage
- Source operands read from register file in decode stage
 - Needs to be in register file at start of stage

Observation

- Value generated in execute or memory stage

Trick

- Pass value directly from generating instruction to decode stage
- Needs to be available at end of decode stage

Data Forwarding Example

```
# demo-h2.y
0x000: irmovl $10,%edx
0x006: irmovl $3,%eax
0x00c: nop
0x00d: nop
0x00e: addl %edx,%eax
0x010: halt
```

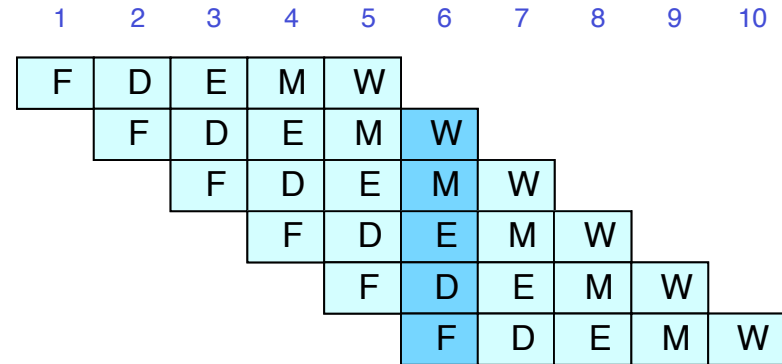

- **irmovl** in write-back stage
- Destination value in W pipeline register
- Forward as valB for decode stage

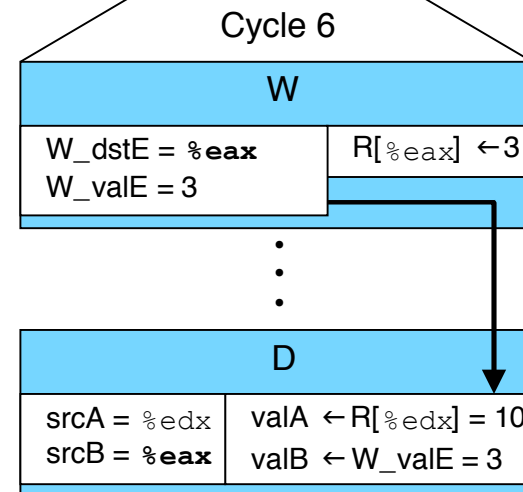

Data Forwarding Example #2

```
# demo-h0.y
0x000: irmovl $10,%edx
0x006: irmovl $3,%eax
0x00c: addl %edx,%eax
0x00e: halt
```

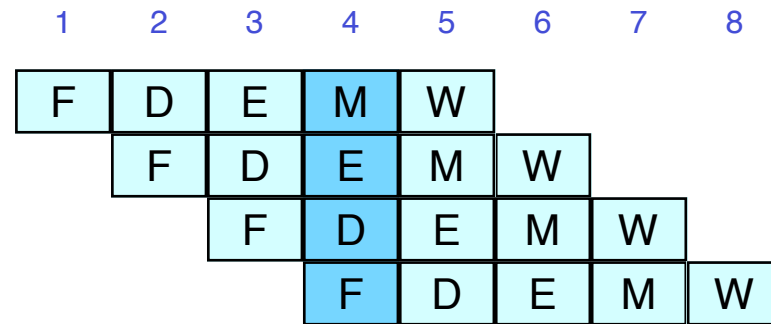

Register %edx

- Generated by ALU during previous cycle
- Forward from memory as valA

Register %eax

- Value just generated by ALU
- Forward from execute as valB

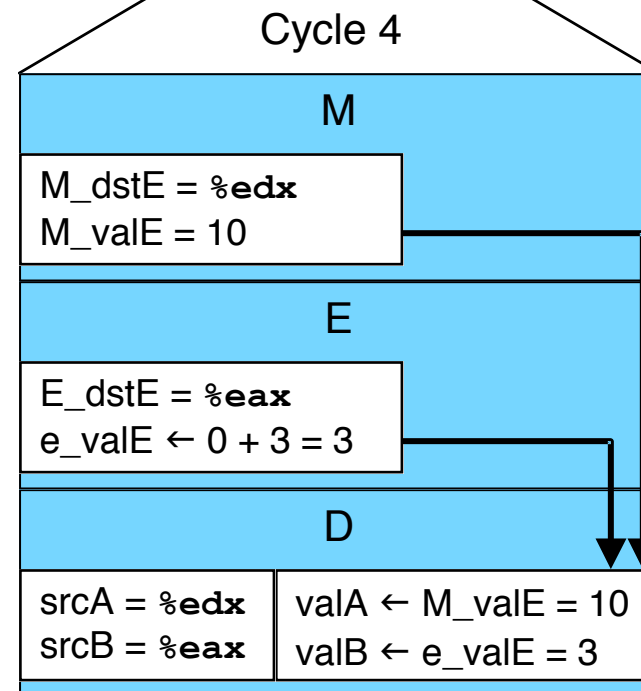

Implementing Forwarding

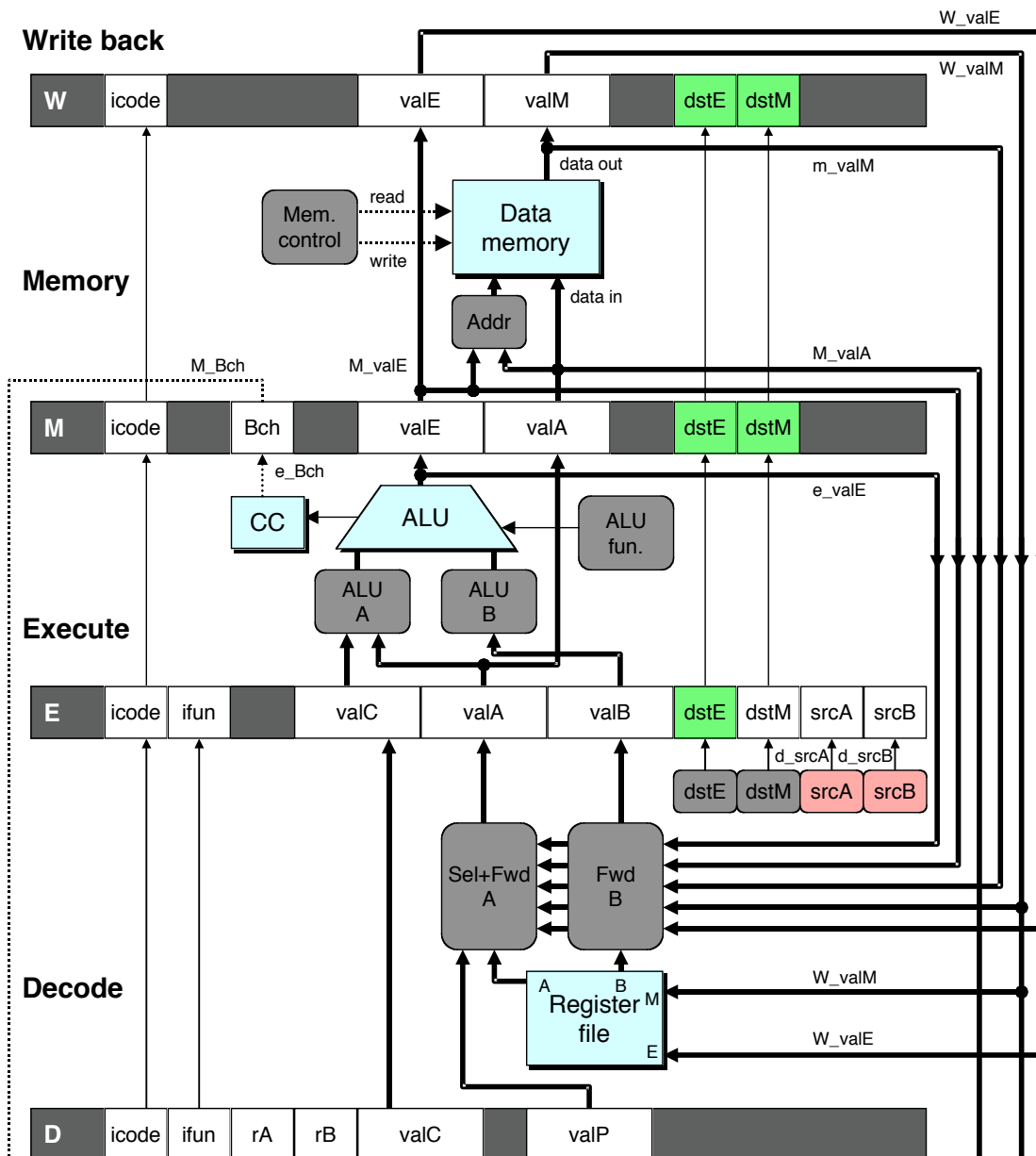

- Add additional feedback paths from E, M, and W pipeline registers into decode stage
- Create logic blocks to select from multiple sources for valA and valB in decode stage

Implementing Forwarding

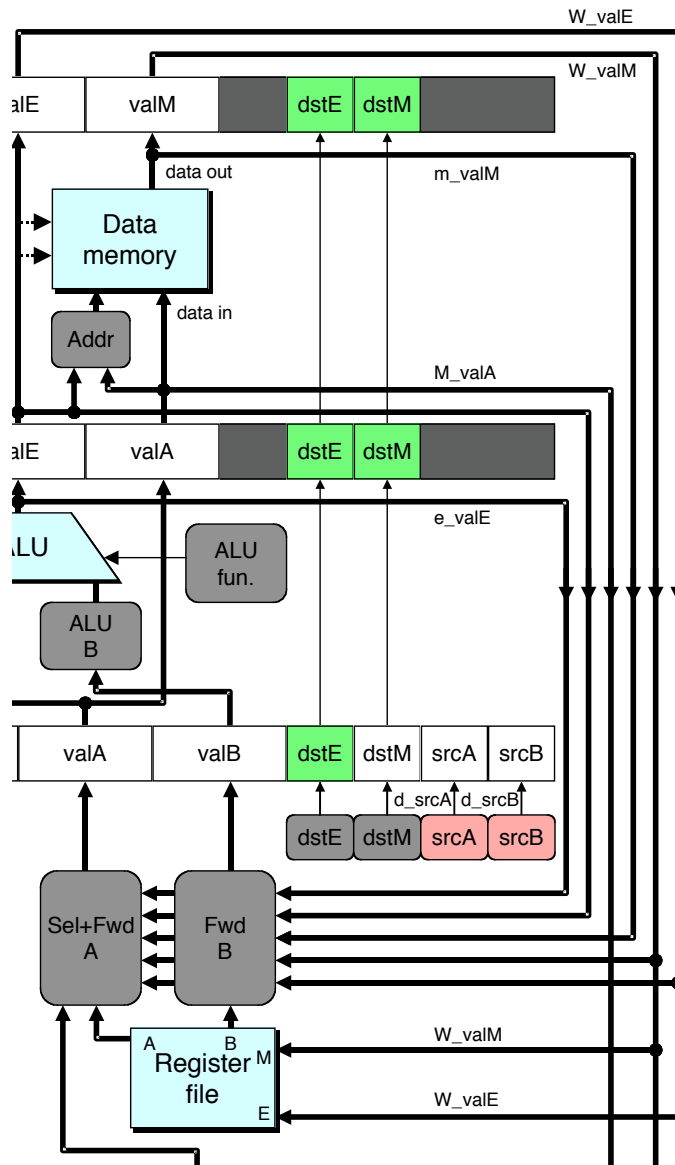

```

## What should be the A value?
int new_E_valA = [
    # Use incremented PC
    D_icode in { ICALL, IJXX } : D_valP;
    # Forward valE from execute
    d_srcA == E_dstE : e_valE;
    # Forward valM from memory
    d_srcA == M_dstM : m_valM;
    # Forward valE from memory
    d_srcA == M_dstE : M_valE;
    # Forward valM from write back
    d_srcA == W_dstM : W_valM;
    # Forward valE from write back
    d_srcA == W_dstE : W_valE;
    # Use value read from register file
    1 : d_rvalA;
];

```

Limitation of Forwarding

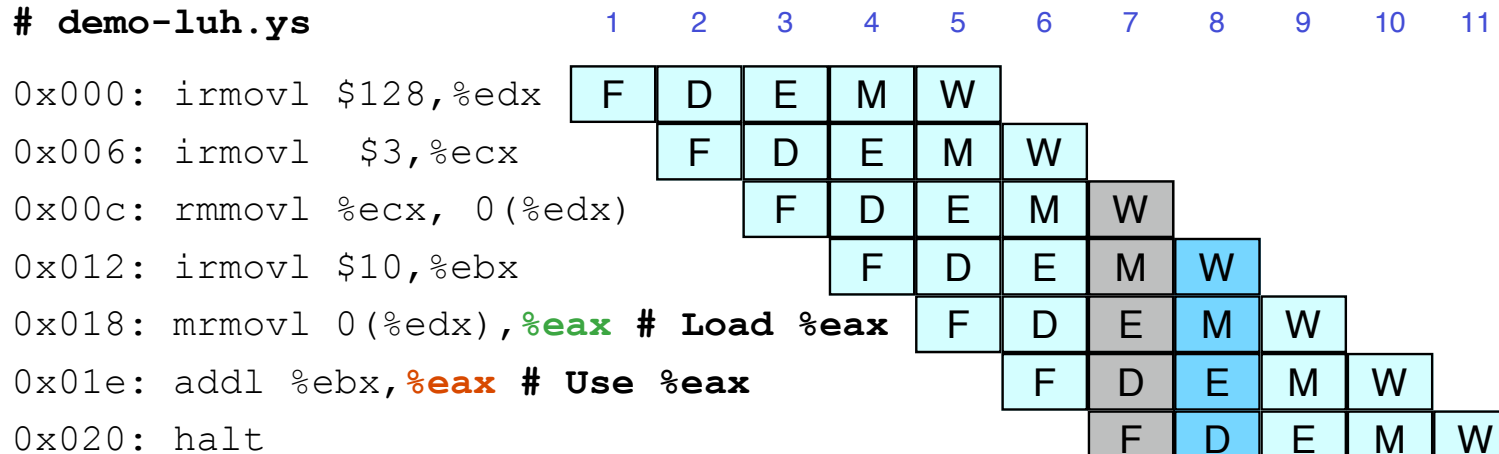

Load-use dependency

- Value needed by end of decode stage in cycle 7
- Value read from memory in memory stage of cycle 8

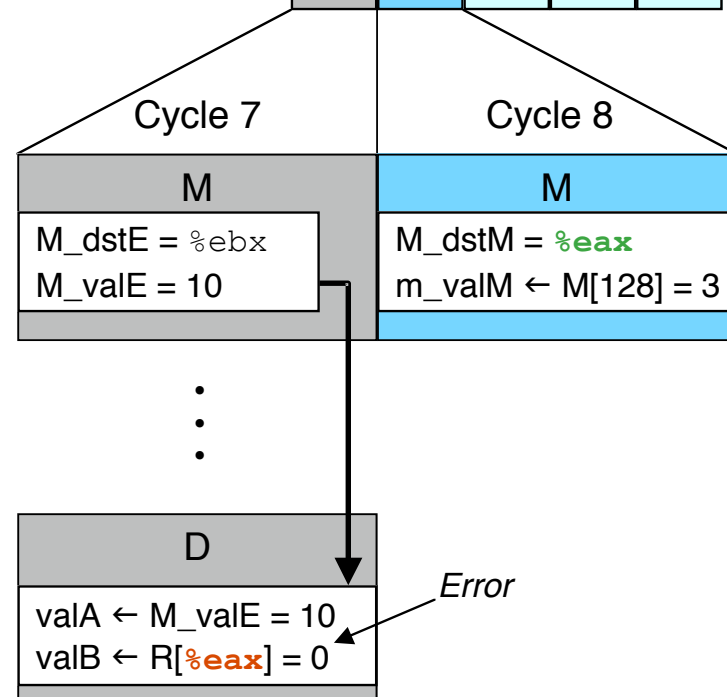

Avoiding Load/Use Hazard

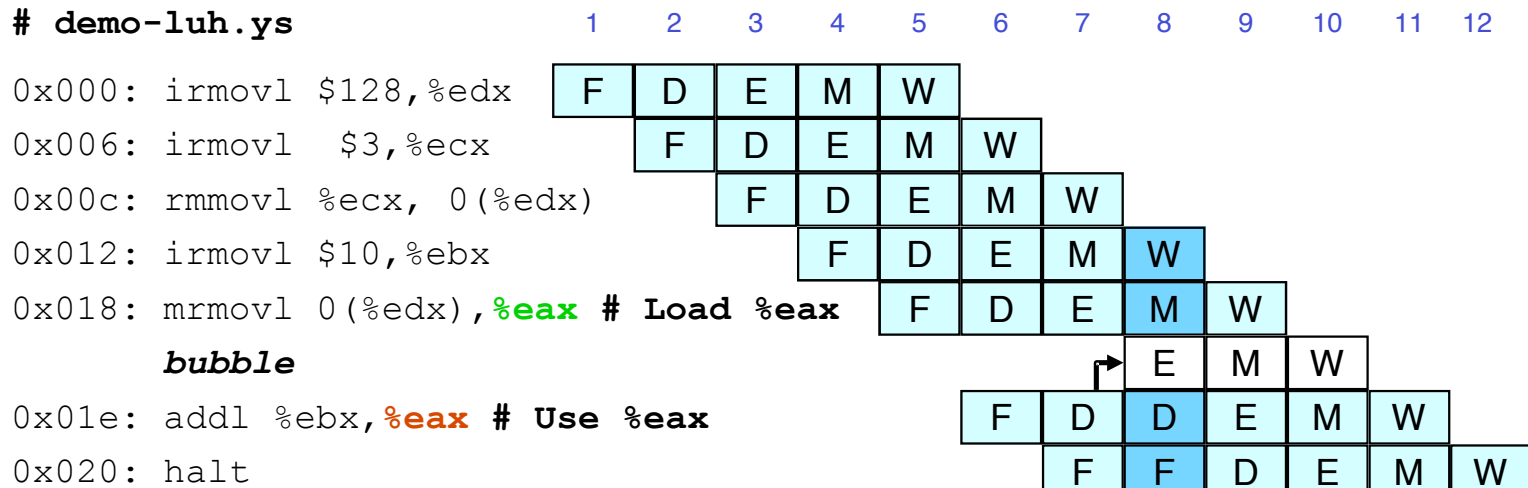

- Stall using instruction for one cycle
- Can then pick up loaded value by forwarding from memory stage

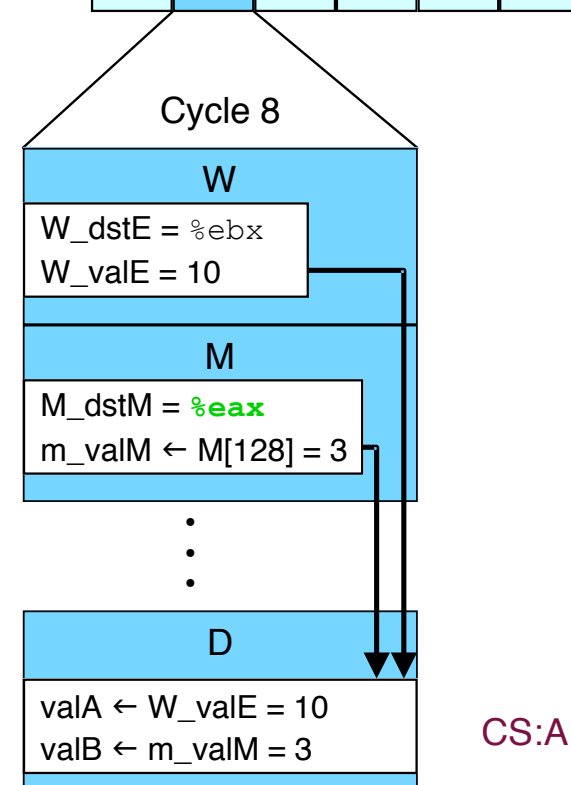

Detecting Load/Use Hazard

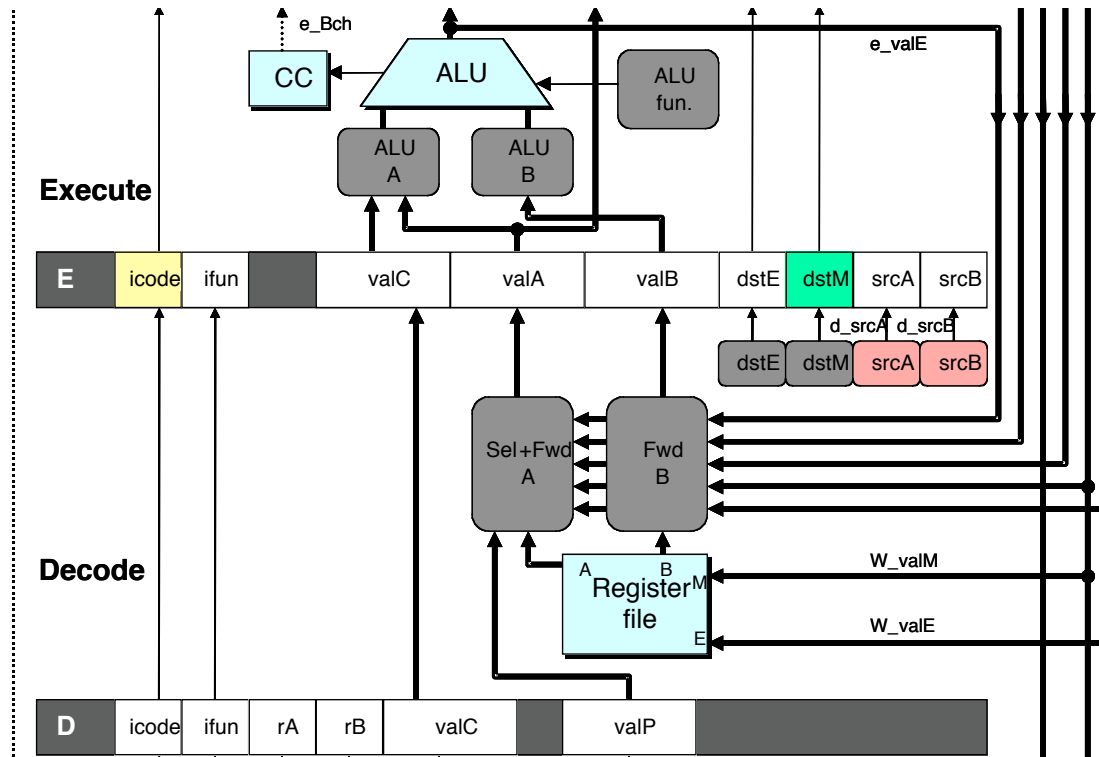

Condition	Trigger
Load/Use Hazard	$E_icode \in \{ IMRMOVL, IPOPL \} \ \&\& \ E_dstM \in \{ d_srcA, d_srcB \}$

Control for Load/Use Hazard

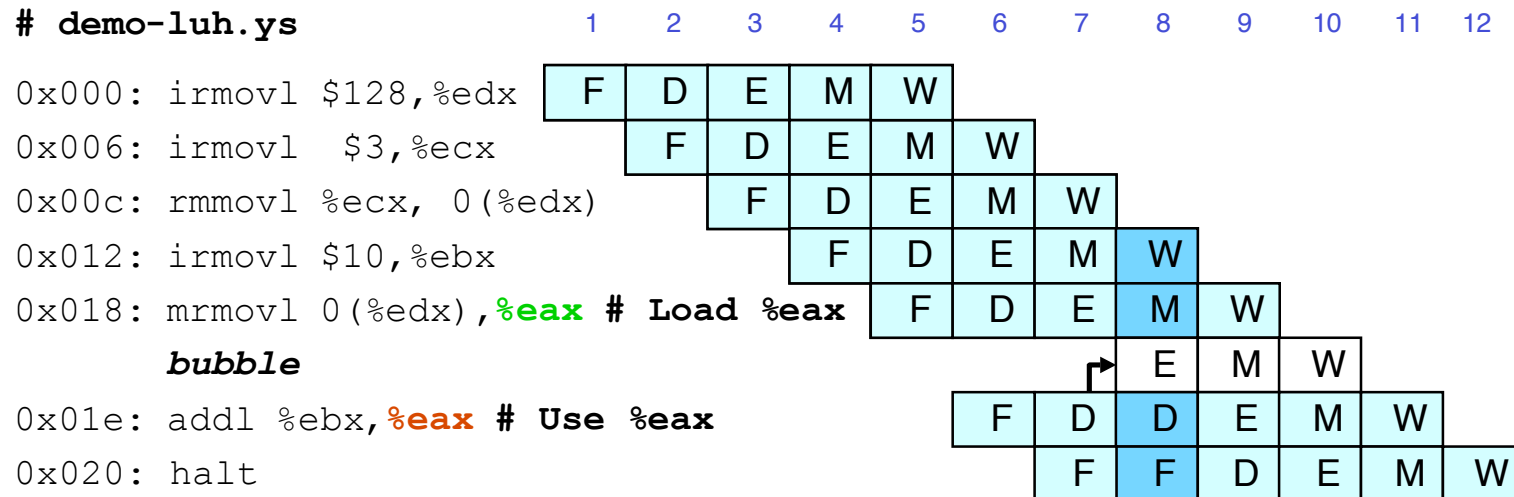

- Stall instructions in fetch and decode stages
- Inject bubble into execute stage

Condition	F	D	E	M	W
Load/Use Hazard	stall	stall	bubble	normal	normal

Branch Misprediction Example

demo-j.ys

```
0x000:    xorl %eax,%eax
0x002:    jne  t                # Not taken
0x007:    irmovl $1, %eax     # Fall through
0x00d:    nop
0x00e:    nop
0x00f:    nop
0x010:    halt
0x011:  t:  irmovl $3, %edx   # Target (Should not execute)
0x017:    irmovl $4, %ecx     # Should not execute
0x01d:    irmovl $5, %edx     # Should not execute
```

- Should only execute first 8 instructions

Handling Misprediction

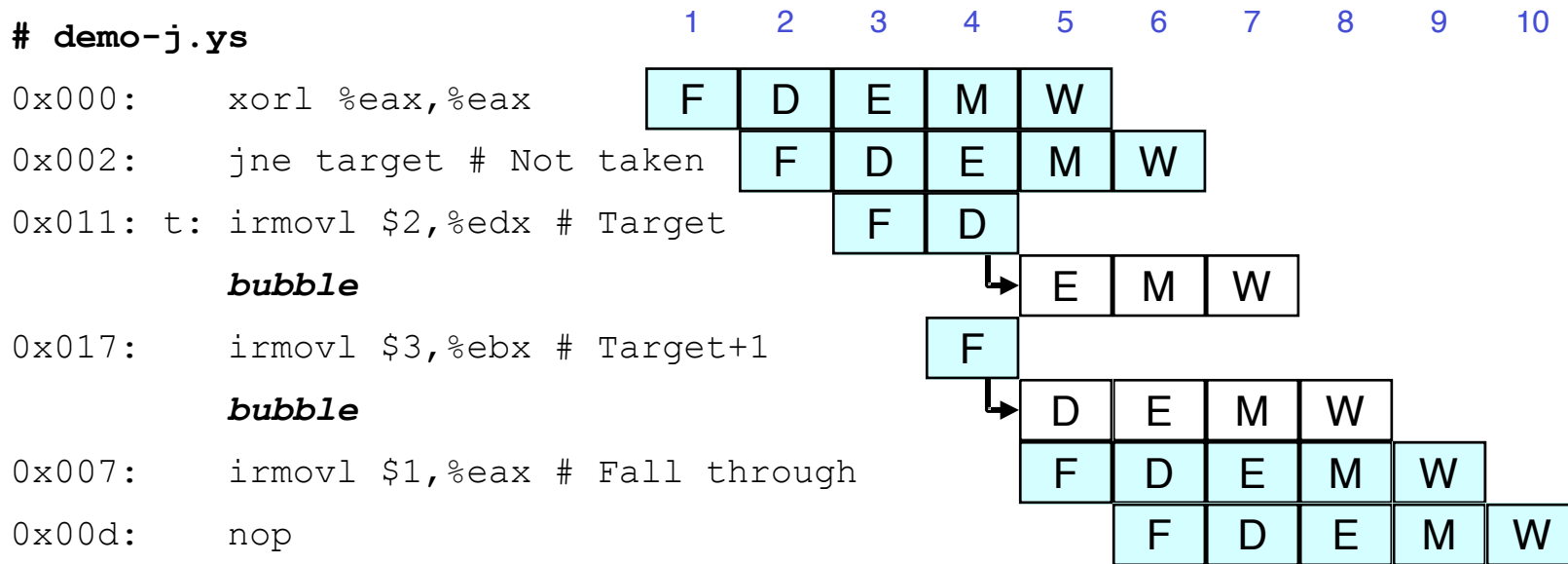

Predict branch as taken

- Fetch 2 instructions at target

Cancel when mispredicted

- Detect branch not-taken in execute stage
- On following cycle, replace instructions in execute and decode by bubbles
- No side effects have occurred yet

Detecting Mispredicted Branch

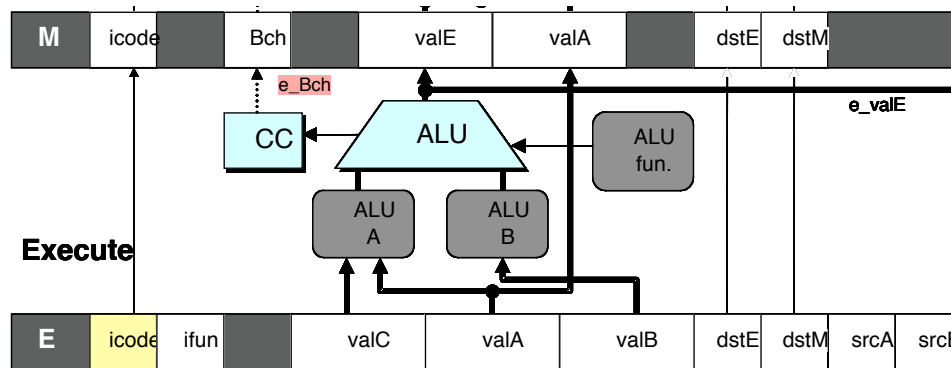

Condition	Trigger
Mispredicted Branch	$E_icode = IJXX \ \& \ !e_Bch$

Control for Misprediction

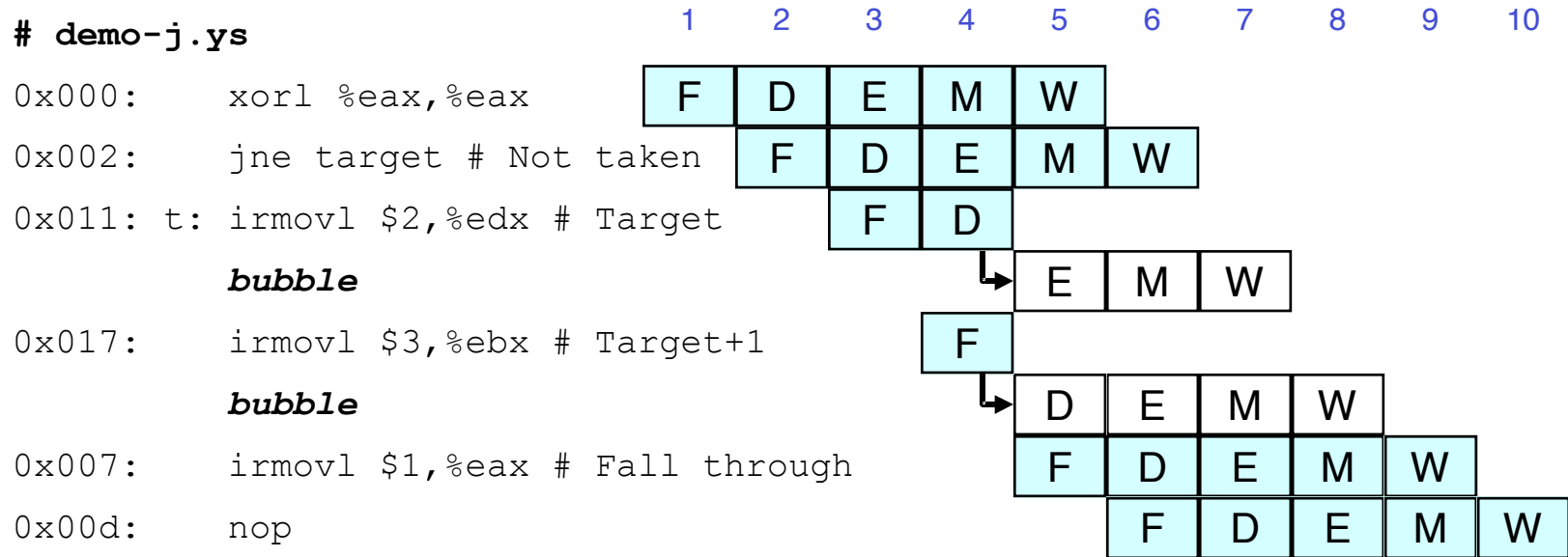

Condition	F	D	E	M	W
Mispredicted Branch	normal	bubble	bubble	normal	normal

Return Example

demo-retb.y

```
0x000:    irmovl Stack,%esp    # Initialize stack pointer
0x006:    call p                # Procedure call
0x00b:    irmovl $5,%esi       # Return point
0x011:    halt
0x020:    .pos 0x20
0x020:    p: irmovl $-1,%edi    # procedure
0x026:    ret
0x027:    irmovl $1,%eax       # Should not be executed
0x02d:    irmovl $2,%ecx       # Should not be executed
0x033:    irmovl $3,%edx       # Should not be executed
0x039:    irmovl $4,%ebx       # Should not be executed
0x100:    .pos 0x100
0x100:    Stack:                # Stack: Stack pointer
```

- Previously executed three additional instructions

Correct Return Example

demo-retb

0x026: ret

bubble

bubble

bubble

0x00b: irmovl \$5,%esi # Return

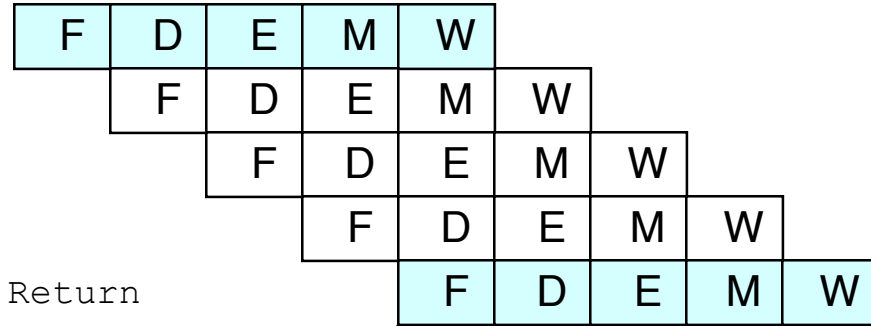

- As `ret` passes through pipeline, stall at fetch stage
 - While in decode, execute, and memory stage
- Inject bubble into decode stage
- Release stall when reach write-back stage

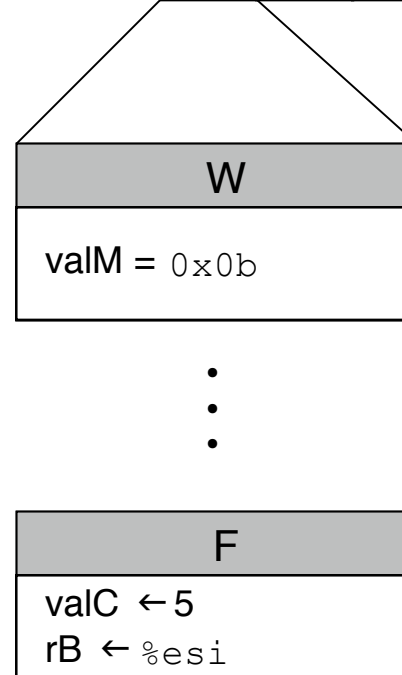

Detecting Return

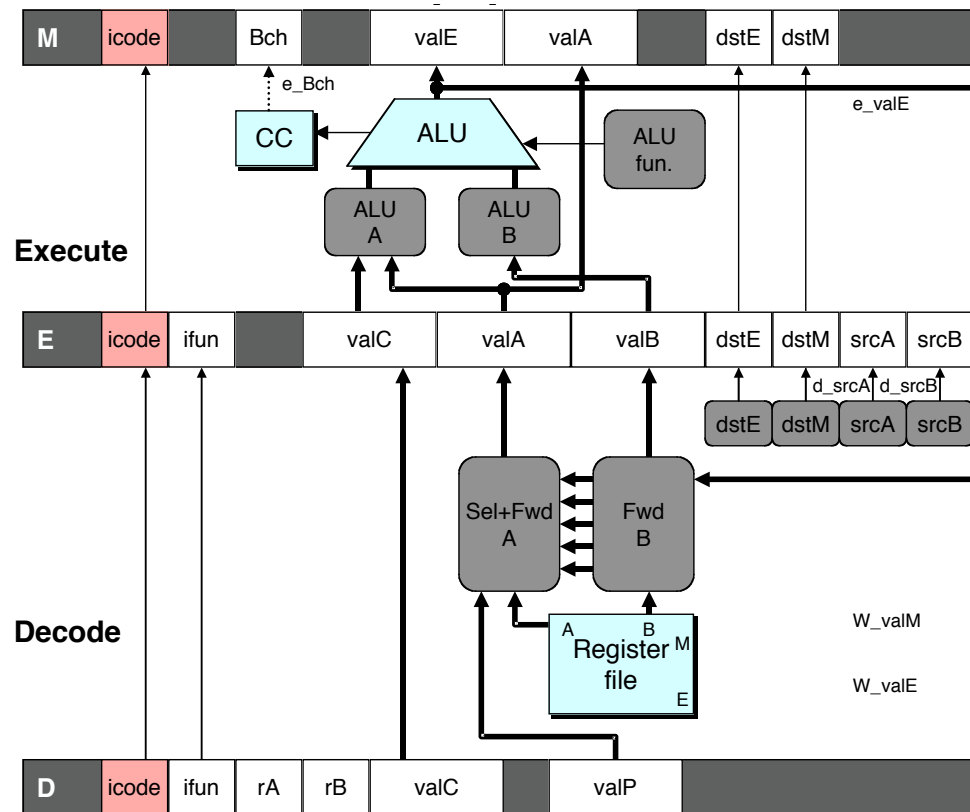

Condition	Trigger
Processing ret	IRET in { D_icode, E_icode, M_icode }

Control for Return

demo-retb

0x026: ret

bubble

bubble

bubble

0x00b: irmovl \$5,%esi # Return

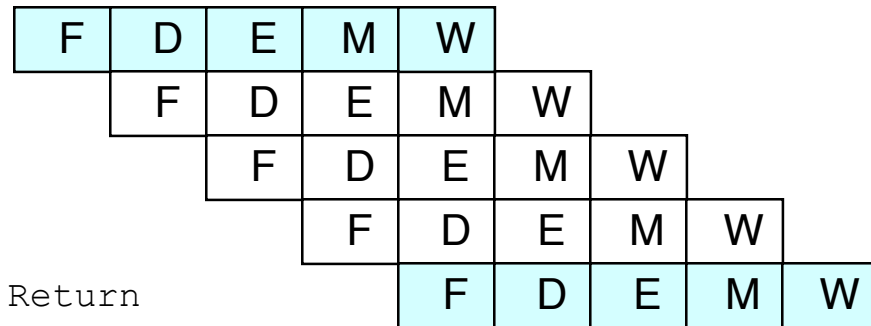

Condition	F	D	E	M	W
Processing ret	stall	bubble	normal	normal	normal

Special Control Cases

Detection

Condition	Trigger
Processing ret	IRET in { D_icode, E_icode, M_icode }
Load/Use Hazard	E_icode in { IMRMOVL, IPOPL } && E_dstM in { d_srcA, d_srcB }
Mispredicted Branch	E_icode = IJXX & !e_Bch

Action (on next cycle)

Condition	F	D	E	M	W
Processing ret	stall	bubble	normal	normal	normal
Load/Use Hazard	stall	stall	bubble	normal	normal
Mispredicted Branch	normal	bubble	bubble	normal	normal

Implementing Pipeline Control

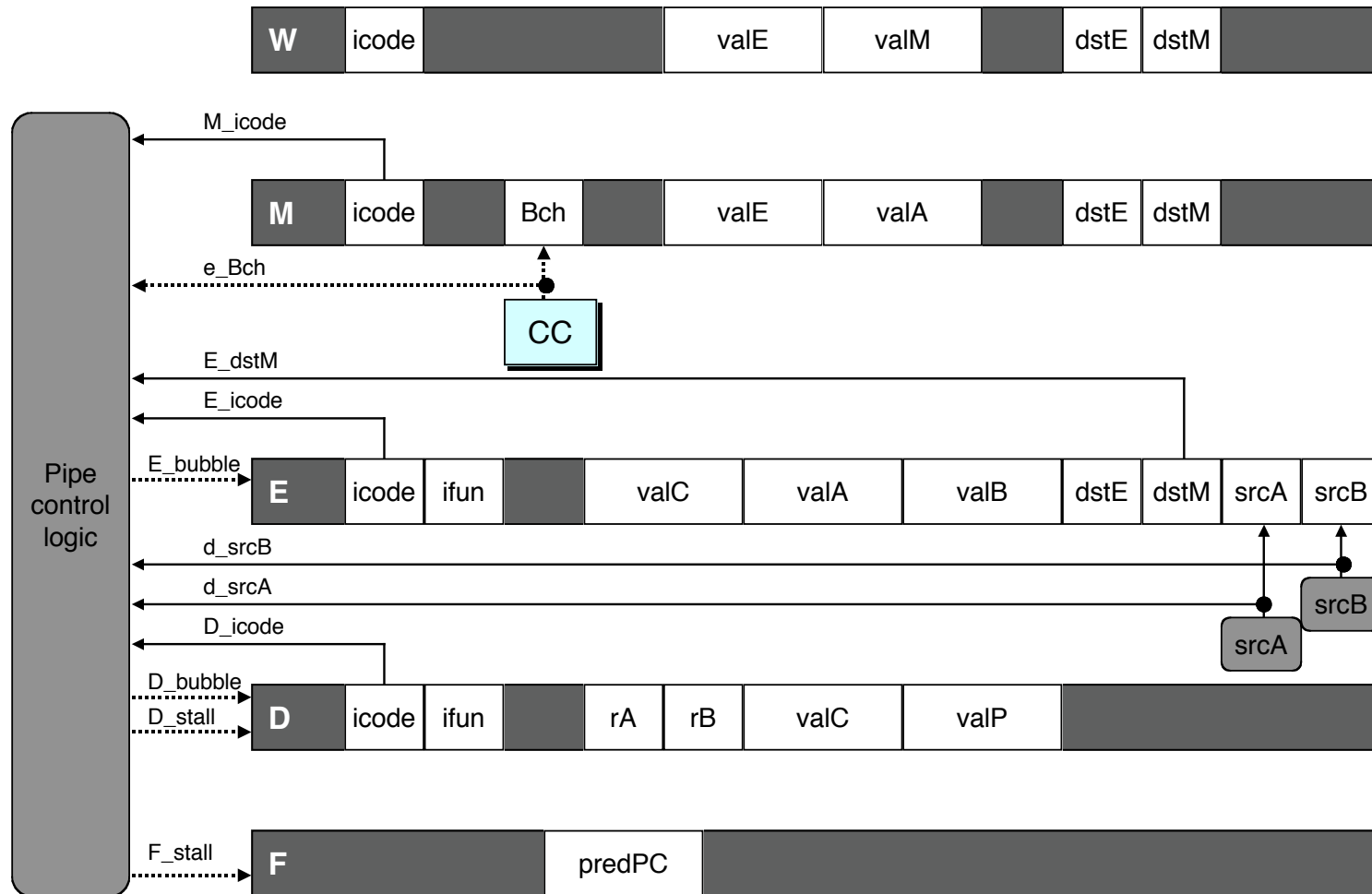

- **Combinational logic generates pipeline control signals**
- **Action occurs at start of following cycle**

Initial Version of Pipeline Control

```
bool F_stall =
    # Conditions for a load/use hazard
    E_icode in { IMRMOVL, IPOPL } && E_dstM in { d_srcA, d_srcB } ||
    # Stalling at fetch while ret passes through pipeline
    IRET in { D_icode, E_icode, M_icode };

bool D_stall =
    # Conditions for a load/use hazard
    E_icode in { IMRMOVL, IPOPL } && E_dstM in { d_srcA, d_srcB };

bool D_bubble =
    # Mispredicted branch
    (E_icode == IJXX && !e_Bch) ||
    # Stalling at fetch while ret passes through pipeline
    IRET in { D_icode, E_icode, M_icode };

bool E_bubble =
    # Mispredicted branch
    (E_icode == IJXX && !e_Bch) ||
    # Load/use hazard
    E_icode in { IMRMOVL, IPOPL } && E_dstM in { d_srcA, d_srcB};
```

Control Combinations

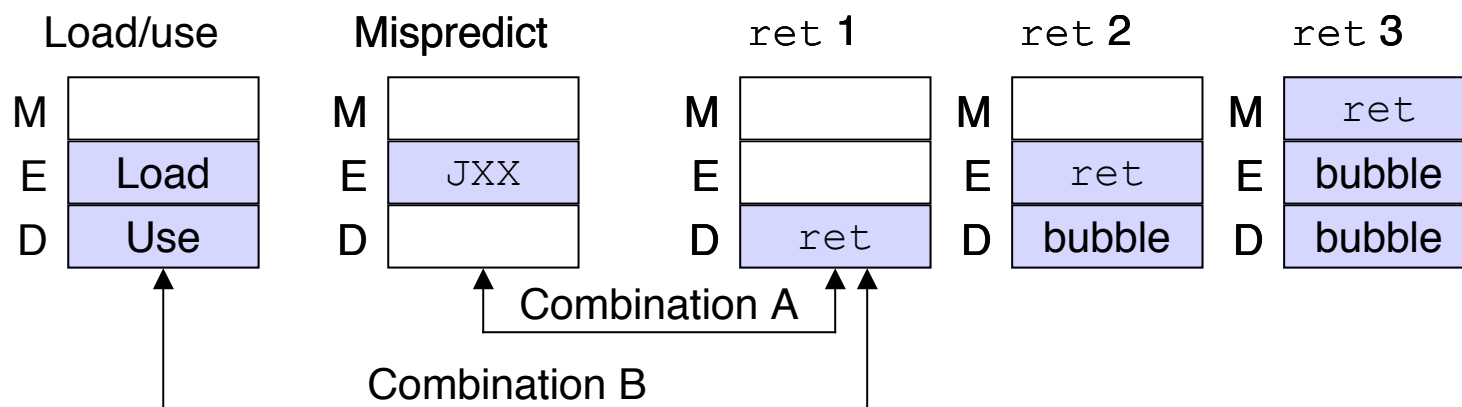

- Special cases that can arise on same clock cycle

Combination A

- Not-taken branch
- `ret` instruction at branch target

Combination B

- Instruction that reads from memory to `%esp`
- Followed by `ret` instruction

Control Combination A

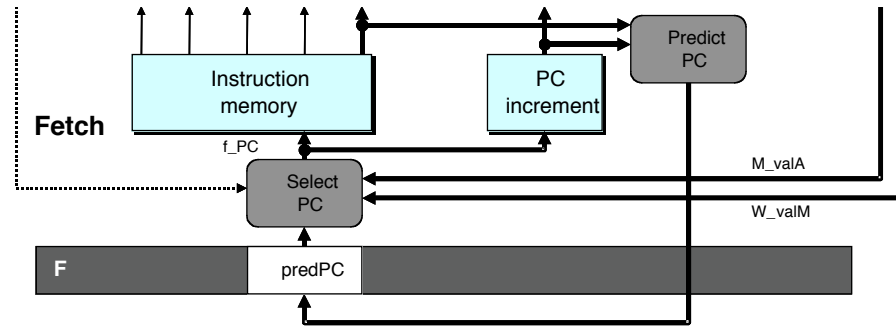
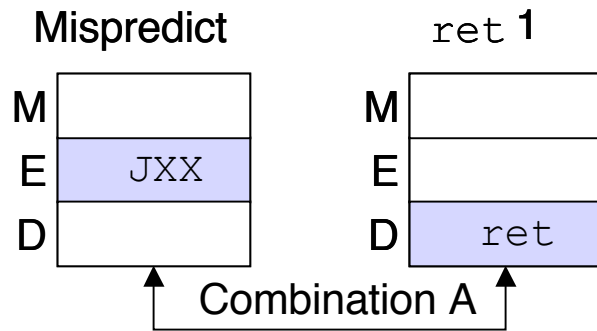

Condition	F	D	E	M	W
Processing ret	stall	bubble	normal	normal	normal
Mispredicted Branch	normal	bubble	bubble	normal	normal
<i>Combination</i>	<i>stall</i>	<i>bubble</i>	<i>bubble</i>	<i>normal</i>	<i>normal</i>

- Should handle as mispredicted branch
- Stalls F pipeline register
- But PC selection logic will be using M_valM anyhow

Control Combination B

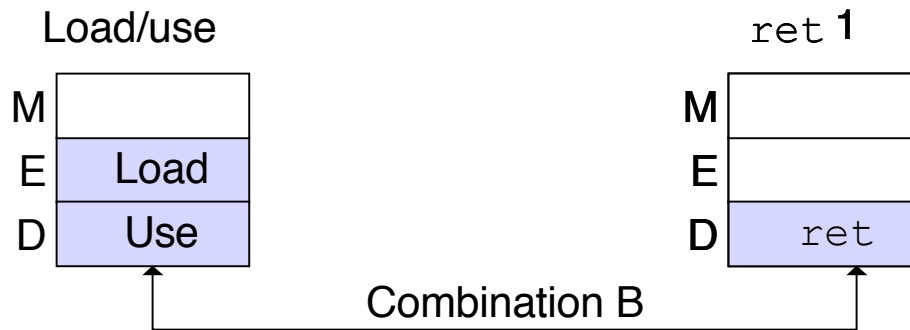

Condition	F	D	E	M	W
Processing ret	stall	bubble	normal	normal	normal
Load/Use Hazard	stall	stall	bubble	normal	normal
<i>Combination</i>	<i>stall</i>	<i>bubble + stall</i>	<i>bubble</i>	<i>normal</i>	<i>normal</i>

- Would attempt to bubble *and* stall pipeline register D
- Signaled by processor as pipeline error

Handling Control Combination B



Condition	F	D	E	M	W
Processing ret	stall	bubble	normal	normal	normal
Load/Use Hazard	stall	stall	bubble	normal	normal
<i>Combination</i>	<i>stall</i>	<i>stall</i>	<i>bubble</i>	<i>normal</i>	<i>normal</i>

- Load/use hazard should get priority
- `ret` instruction should be held in decode stage for additional cycle

Corrected Pipeline Control Logic

```
bool D_bubble =  
    # Mispredicted branch  
    (E_icode == IJXX && !e_Bch) ||  
    # Stalling at fetch while ret passes through pipeline  
    IRET in { D_icode, E_icode, M_icode }  
    # but not condition for a load/use hazard  
    && !(E_icode in { IMRMOVL, IPOPL }  
        && E_dstM in { d_srcA, d_srcB });
```

Condition	F	D	E	M	W
Processing ret	stall	bubble	normal	normal	normal
Load/Use Hazard	stall	stall	bubble	normal	normal
<i>Combination</i>	<i>stall</i>	<i>stall</i>	<i>bubble</i>	<i>normal</i>	<i>normal</i>

- Load/use hazard should get priority
- ret instruction should be held in decode stage for additional cycle

Pipeline Summary

Data Hazards

- Most handled by forwarding
 - No performance penalty
- Load/use hazard requires one cycle stall

Control Hazards

- Cancel instructions when detect mispredicted branch
 - Two clock cycles wasted
- Stall fetch stage while `ret` passes through pipeline
 - Three clock cycles wasted

Control Combinations

- Must analyze carefully
- First version had subtle bug
 - Only arises with unusual instruction combination