

# 15-213

“The course that gives CMU its Zip!”

## P6/Linux Memory System Oct. 31, 2002

### Topics

- P6 address translation
- Linux memory management
- Linux page fault handling
- memory mapping

class20.ppt

## P6 Memory System

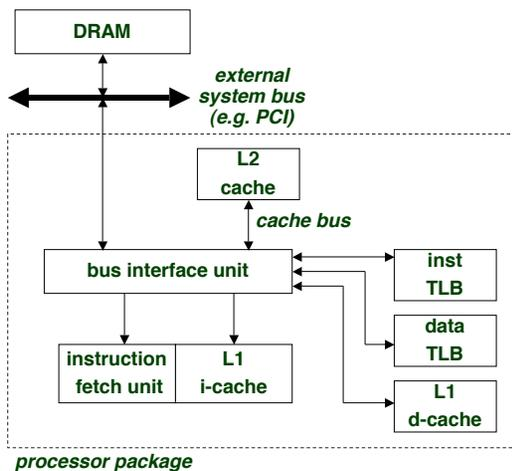

32 bit address space

4 KB page size

L1, L2, and TLBs

- 4-way set associative

inst TLB

- 32 entries
- 8 sets

data TLB

- 64 entries
- 16 sets

L1 i-cache and d-cache

- 16 KB
- 32 B line size
- 128 sets

L2 cache

- unified
- 128 KB -- 2 MB

## Intel P6

### Internal Designation for Successor to Pentium

- Which had internal designation P5

### Fundamentally Different from Pentium

- Out-of-order, superscalar operation
- Designed to handle server applications
  - Requires high performance memory system

### Resulting Processors

- PentiumPro (1996)
- Pentium II (1997)
  - Incorporated MMX instructions
    - » special instructions for parallel processing
  - L2 cache on same chip
- Pentium III (1999)
  - Incorporated Streaming SIMD Extensions
    - » More instructions for parallel processing

- 2 -

15-213, F'02

## Review of Abbreviations

### Symbols:

- Components of the virtual address (VA)
  - TLBI: TLB index
  - TLBT: TLB tag
  - VPO: virtual page offset
  - VPN: virtual page number
- Components of the physical address (PA)
  - PPO: physical page offset (same as VPO)
  - PPN: physical page number
  - CO: byte offset within cache line
  - CI: cache index
  - CT: cache tag

- 3 -

15-213, F'02

- 4 -

15-213, F'02

# Overview of P6 Address Translation

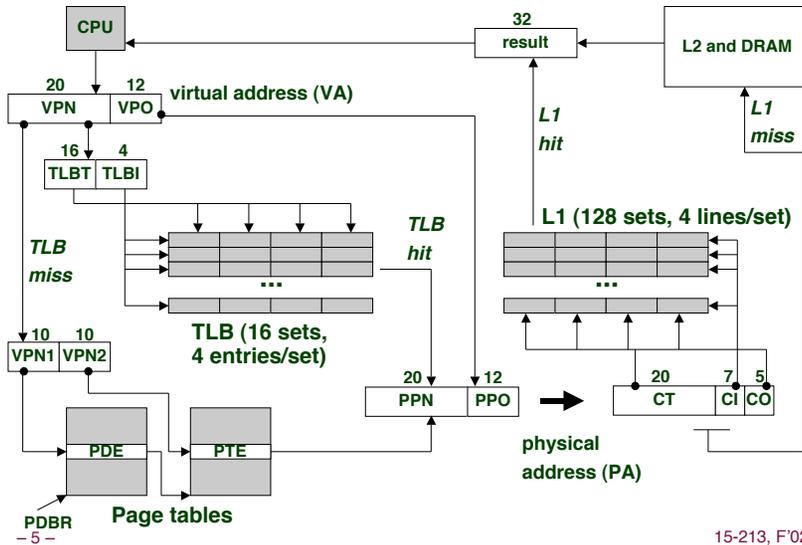

# P6 2-level Page Table Structure

## Page directory

- 1024 4-byte page directory entries (PDEs) that point to page tables
- one page directory per process.
- page directory must be in memory when its process is running
- always pointed to by PDBR

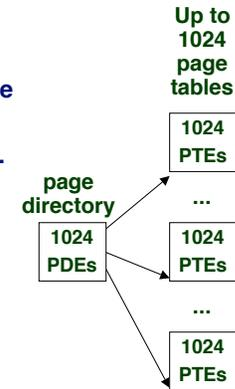

## Page tables:

- 1024 4-byte page table entries (PTEs) that point to pages.
- page tables can be paged in and out.

# P6 Page Directory Entry (PDE)

31	12	11	9	8	7	6	5	4	3	2	1	0
Page table physical base addr		Avail	G	PS	A	CD	WT	U/S	R/W	P=1		

**Page table physical base address:** 20 most significant bits of physical page table address (forces page tables to be 4KB aligned)

**Avail:** These bits available for system programmers

**G:** global page (don't evict from TLB on task switch)

**PS:** page size 4K (0) or 4M (1)

**A:** accessed (set by MMU on reads and writes, cleared by software)

**CD:** cache disabled (1) or enabled (0)

**WT:** write-through or write-back cache policy for this page table

**U/S:** user or supervisor mode access

**R/W:** read-only or read-write access

**P:** page table is present in memory (1) or not (0)

31	1	0
Available for OS (page table location in secondary storage)		P=0

# P6 Page Table Entry (PTE)

31	12	11	9	8	7	6	5	4	3	2	1	0
Page physical base address		Avail	G	0	D	A	CD	WT	U/S	R/W	P=1	

**Page base address:** 20 most significant bits of physical page address (forces pages to be 4 KB aligned)

**Avail:** available for system programmers

**G:** global page (don't evict from TLB on task switch)

**D:** dirty (set by MMU on writes)

**A:** accessed (set by MMU on reads and writes)

**CD:** cache disabled or enabled

**WT:** write-through or write-back cache policy for this page

**U/S:** user/supervisor

**R/W:** read/write

**P:** page is present in physical memory (1) or not (0)

31	1	0
Available for OS (page location in secondary storage)		P=0

# How P6 Page Tables Map Virtual Addresses to Physical Ones

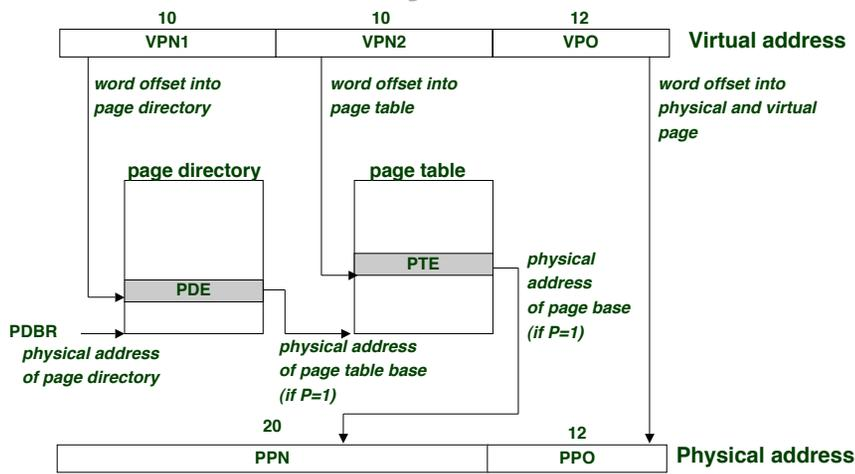

# Representation of Virtual Address Space

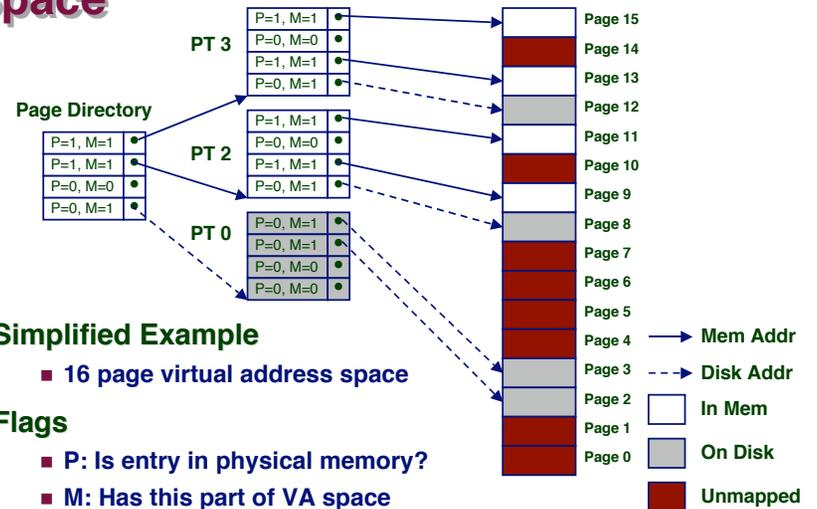

## Simplified Example

- 16 page virtual address space

## Flags

- P: Is entry in physical memory?
- M: Has this part of VA space been mapped?

# P6 TLB Translation

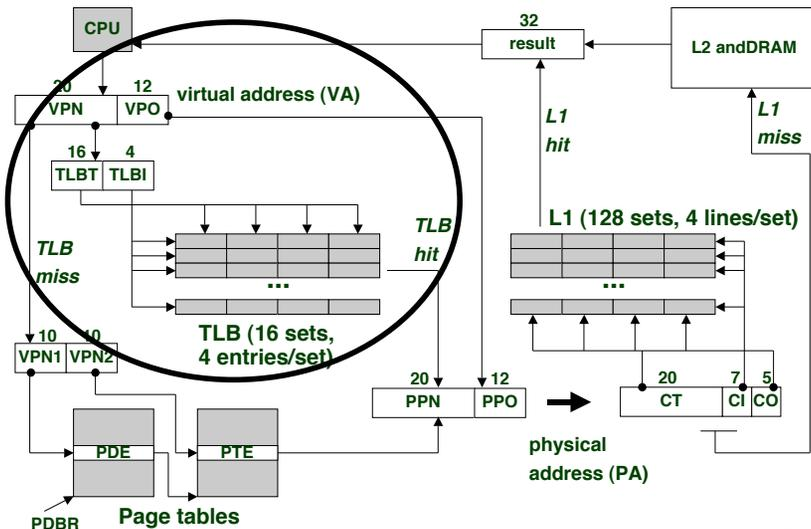

# P6 TLB

TLB entry (not all documented, so this is speculative):

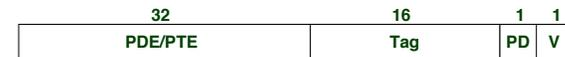

- V: indicates a valid (1) or invalid (0) TLB entry
- PD: is this entry a PDE (1) or a PTE (0)?
- tag: disambiguates entries cached in the same set
- PDE/PTE: page directory or page table entry

## Structure of the data TLB:

- 16 sets, 4 entries/set



# Translating with the P6 TLB

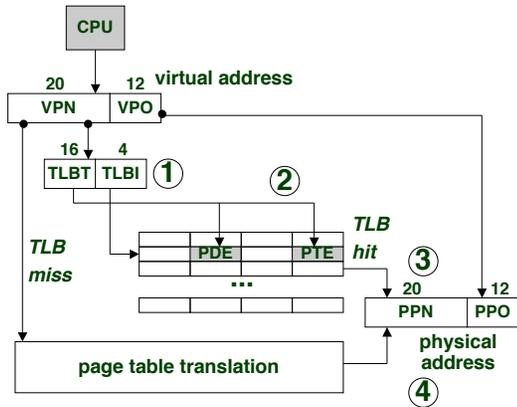

1. Partition VPN into TLBT and TLBI.
2. Is the PTE for VPN cached in set TLBI?
  - 3. **Yes:** then build physical address.
  - 4. **No:** then read PTE (and PDE if not cached) from memory and build physical address.

# P6 page table translation

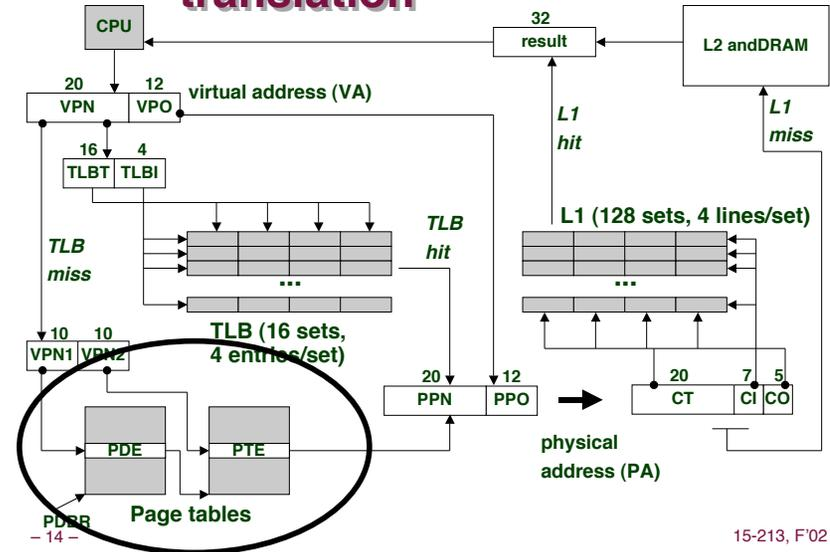

# Translating with the P6 Page Tables (case 1/1)

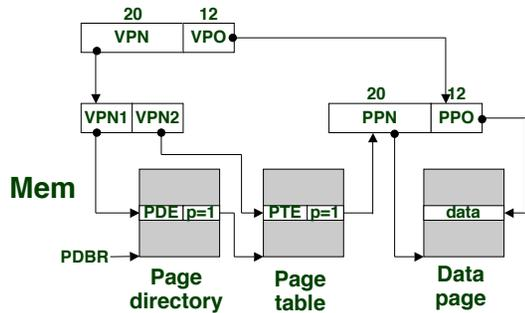

Case 1/1: page table and page present.

MMU Action:

- MMU builds physical address and fetches data word.

OS action

- none

Disk

# Translating with the P6 Page Tables (case 1/0)

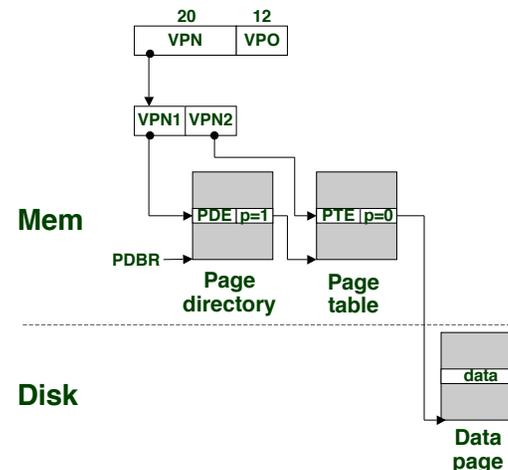

Case 1/0: page table present but page missing.

MMU Action:

- page fault exception
- handler receives the following args:

- VA that caused fault
- fault caused by non-present page or page-level protection violation
- read/write
- user/supervisor

Disk

## Translating with the P6 Page Tables (case 1/0, cont)

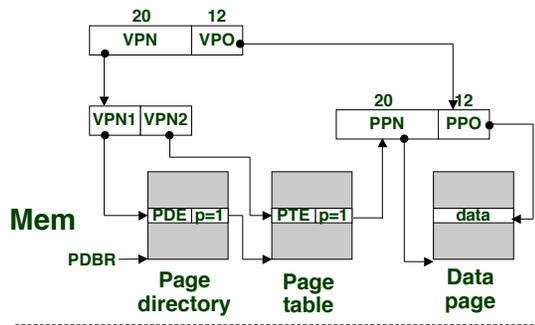

### OS Action:

- Check for a legal virtual address.
- Read PTE through PDE.
- Find free physical page (swapping out current page if necessary)
- Read virtual page from disk and copy to virtual page
- Restart faulting instruction by returning from exception handler.

Disk

## Translating with the P6 Page Tables (case 0/1)

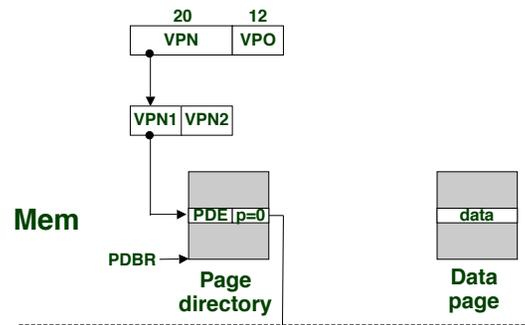

Case 0/1: page table missing but page present.

Introduces consistency issue.

- potentially every page out requires update of disk page table.

Linux disallows this

- if a page table is swapped out, then swap out its data pages too.

Mem

Disk

## Translating with the P6 Page Tables (case 0/0)

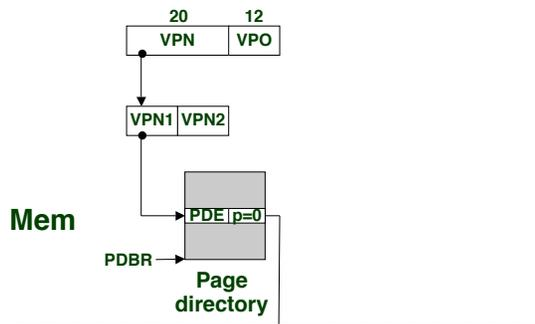

Case 0/0: page table and page missing.

### MMU Action:

- page fault exception

Disk

## Translating with the P6 Page Tables (case 0/0, cont)

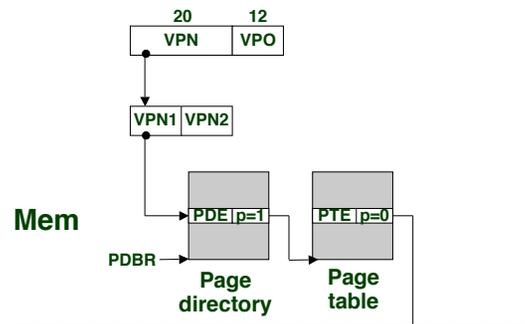

### OS action:

- swap in page table.
- restart faulting instruction by returning from handler.

Like case 0/1 from here on.

Mem

Disk

## P6 L1 Cache Access

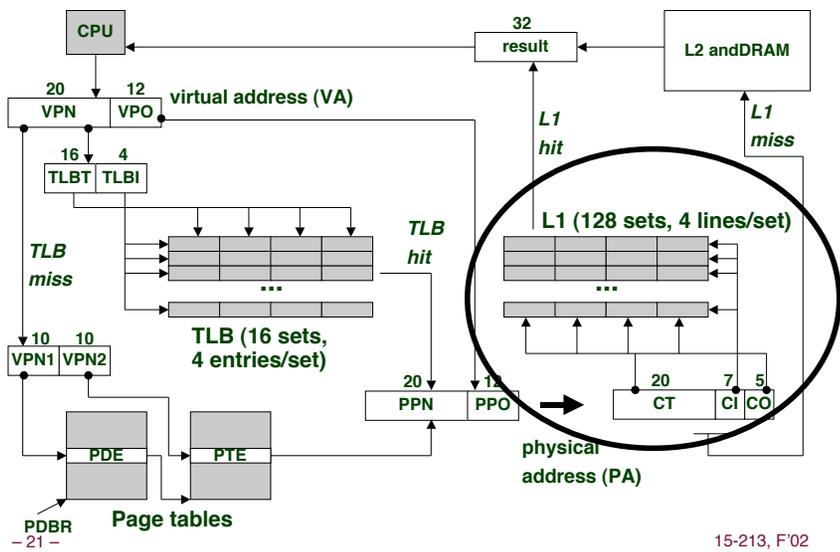

15-213, F'02

## L1 Cache Access

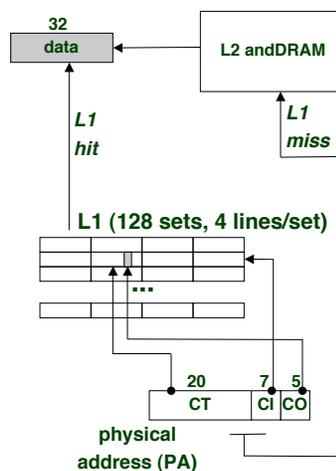

- 22 -

Partition physical address into CO, CI, and CT.

Use CT to determine if line containing word at address PA is cached in set CI.

If no: check L2.

If yes: extract word at byte offset CO and return to processor.

15-213, F'02

## Speeding Up L1 Access

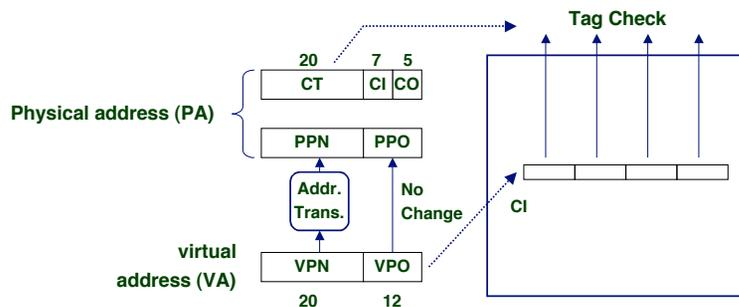

### Observation

- Bits that determine CI identical in virtual and physical address
- Can index into cache while address translation taking place
- Then check with CT from physical address
- “Virtually indexed, physically tagged”
- Cache carefully sized to make this possible

- 23 -

15-213, F'02

## Linux Organizes VM as Collection of “Areas”

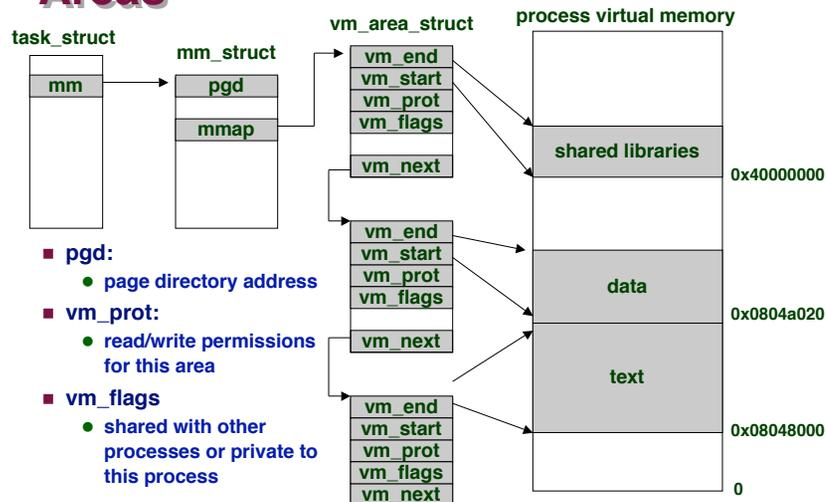

- 24 -

15-213, F'02

# Linux Page Fault Handling

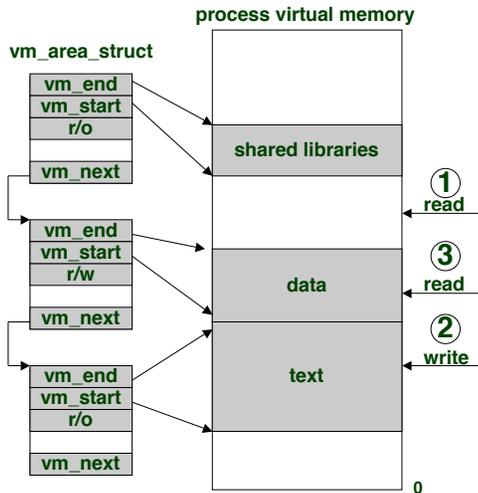

## Is the VA legal?

- i.e. is it in an area defined by a `vm_area_struct`?
- if not then signal segmentation violation (e.g. (1))

## Is the operation legal?

- i.e., can the process read/write this area?
- if not then signal protection violation (e.g., (2))

## If OK, handle fault

- e.g., (3)

15-213, F'02

- 25 -

# Memory Mapping

## Creation of new VM area done via “memory mapping”

- create new `vm_area_struct` and page tables for area
- area can be backed by (i.e., get its initial values from) :
  - regular file on disk (e.g., an executable object file)
    - » initial page bytes come from a section of a file
  - nothing (e.g., `bss`)
    - » initial page bytes are zeros
- dirty pages are swapped back and forth between a special swap file.

## Key point: no virtual pages are copied into physical memory until they are referenced!

- known as “demand paging”
- crucial for time and space efficiency

- 26 -

15-213, F'02

# User-Level Memory Mapping

```
void *mmap(void *start, int len,
           int prot, int flags, int fd, int offset)
```

- map `len` bytes starting at offset `offset` of the file specified by file description `fd`, preferably at address `start` (usually 0 for don't care).
  - `prot`: `MAP_READ`, `MAP_WRITE`
  - `flags`: `MAP_PRIVATE`, `MAP_SHARED`
- return a pointer to the mapped area.
- Example: fast file copy
  - useful for applications like Web servers that need to quickly copy files.
  - `mmap` allows file transfers without copying into user space.

- 27 -

15-213, F'02

# mmap() Example: Fast File Copy

```
#include <unistd.h>
#include <sys/mman.h>
#include <sys/types.h>
#include <sys/stat.h>
#include <fcntl.h>

/*
 * mmap.c - a program that uses mmap
 * to copy itself to stdout
 */
```

```
int main() {
    struct stat stat;
    int i, fd, size;
    char *bufp;

    /* open the file & get its size*/
    fd = open("./mmap.c", O_RDONLY);
    fstat(fd, &stat);
    size = stat.st_size;
    /* map the file to a new VM area */
    bufp = mmap(0, size, PROT_READ,
                MAP_PRIVATE, fd, 0);

    /* write the VM area to stdout */
    write(1, bufp, size);
}
```

- 28 -

15-213, F'02

# Exec() Revisited

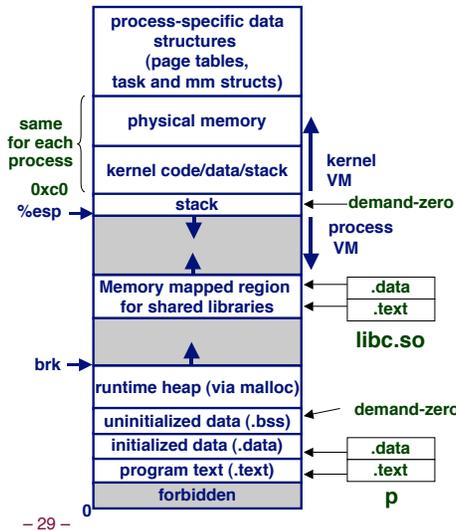

To run a new program `p` in the current process using `exec()`:

- free `vm_area_struct`'s and page tables for old areas.
- create new `vm_area_struct`'s and page tables for new areas.
  - stack, bss, data, text, shared libs.
  - text and data backed by ELF executable object file.
  - bss and stack initialized to zero.
- set PC to entry point in `.text`
  - Linux will swap in code and data pages as needed.

- 29 -

15-213, F'02

# Fork() Revisited

To create a new process using `fork()`:

- make copies of the old process's `mm_struct`, `vm_area_struct`'s, and page tables.
  - at this point the two processes are sharing all of their pages.
  - How to get separate spaces without copying all the virtual pages from one space to another?
    - » "copy on write" technique.
- copy-on-write
  - make pages of writeable areas read-only
  - flag `vm_area_struct`'s for these areas as private "copy-on-write".
  - writes by either process to these pages will cause page faults.
    - » fault handler recognizes copy-on-write, makes a copy of the page, and restores write permissions.
- Net result:
  - copies are deferred until absolutely necessary (i.e., when one of the processes tries to modify a shared page).

- 30 -

15-213, F'02

# Memory System Summary

## Cache Memory

- Purely a speed-up technique
- Behavior invisible to application programmer and OS
- Implemented totally in hardware

## Virtual Memory

- Supports many OS-related functions
  - Process creation
    - » Initial
    - » Forking children
  - Task switching
  - Protection
- Combination of hardware & software implementation
  - Software management of tables, allocations
  - Hardware access of tables
  - Hardware caching of table entries (TLB)

- 31 -

15-213, F'02