

Circuits: black box

"Thinking outside the box."

Abstraction: sometimes we need to see the details of how a circuit is built

Other times, we only need to know what it does

Black box: represents only inputs and outputs

Example:

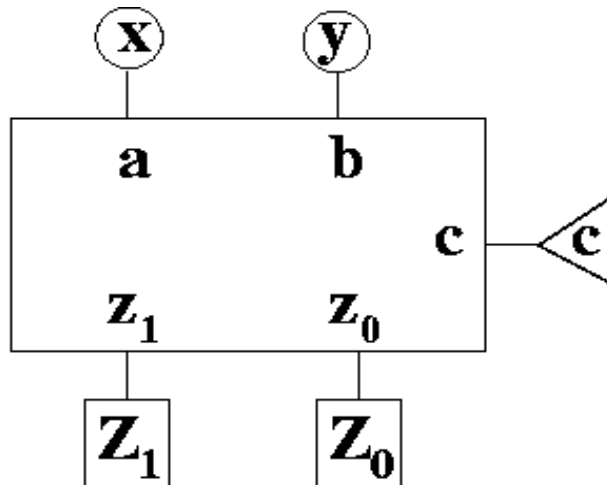

Conventions:

Data inputs are circled: x, y

Control inputs are written in triangles
or trapezoids: c

Outputs are squared: z₀, z₁

Hardwired 0's and 1's can be written as
just 0's and 1's (no shape)

Think of it like a function with arguments, parameters, and return values.

arguments: inputs

parameters: labels for inputs inside box

return values: outputs

You don't need to know how the function works in order to use it.

This document was created with Win2PDF available at <http://www.daneprairie.com>.
The unregistered version of Win2PDF is for evaluation or non-commercial use only.