

Announcements

- Reading
 - Today: Chapter 5 (5.5-5.6)
- Project #3
 - Is on the web
- Midterm #1
 - Next Tuesday Oct. 9
 - Cover material through today's lecture

Load Shedding

- When all else fails, routers drop (discard) packets
- Policy question: what packets to drop?
 - oldest ones: they are likely to be useless now
 - newest ones: helps to close open window in file transfer
 - less important ones
 - requires cooperation of application
 - in MPEG I frames are more important than B frames
 - drop all related packets
 - fragmentation: loss of one packet renders others useless
 - requires information from higher levels
- Preemptive shedding
 - when traffic starts to get high, dropping packets can prevent additional congestion

RSVP - Multicast Bandwidth Reservation

- Receivers send request to reserve BW up spanning tree
- Routers propagate request up tree
 - only sent if greater than prev. request for this group
- Dest. can request BW for multiple alternative sources
 - routers only allocate bandwidth for maximum channel request

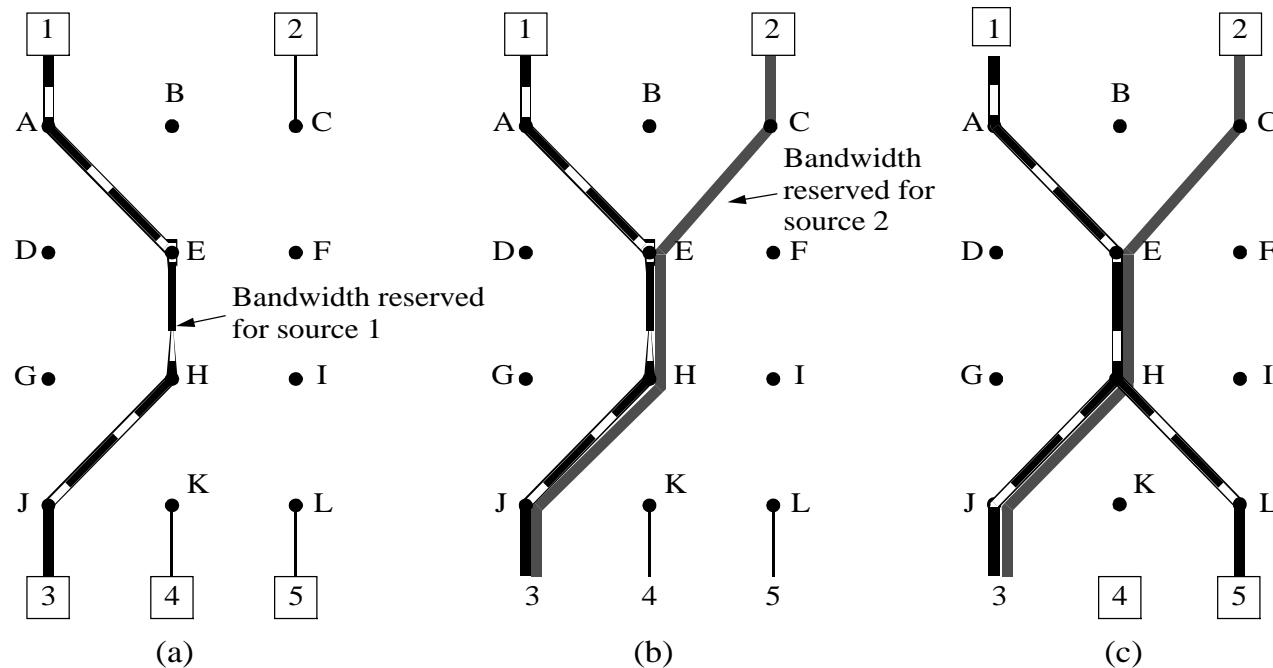

From: *Computer Networks*, 3rd Ed. by Andrew S. Tanenbaum, (c)1996 Prentice Hall.

Internetworking

- **Goal: seamless operation over multiple subnets**
 - could be two similar LANs
 - link WANs to LANs
 - link two different LANs together
- **Issues:**
 - packet size limits (different networks may have different limits)
 - quality of service (is it provided, how is it defined)
 - congestion control
 - connection vs. connectionless networks
- **Possible at many levels**
 - physical layer: repeaters
 - link layer: bridges - regenerate traffic, some filtering
 - network: routers - route packets between networks
 - transport: gateway byte streams
 - application: gateway email between two different systems

Firewalls

- **A way to limit information flow**
 - selective forwarding of information based on **policy**
 - policy: rules about what should be permitted
 - mechanism: way to enforce policy
- **Can be implemented at many levels**
 - at higher layers have more information
 - at lower layers can share filtering between multiple higher level entities
- **Possible Layers**
 - link layer: filter based on MAC address
 - network layer: filter based on source/destination, transport
 - transport: filter based on service (e.g. port number)
 - application: filter based on user name in email, based on content

Tunneling

- Problem

- Source and Destination are compatible
- something in the middle is not compatible

- Solution: Tunnel through the middle

- only multi-protocol routers need to understand conversion
- possible to tunnel through almost anything
 - can tunnel IP through IP (for mobile computing perhaps)

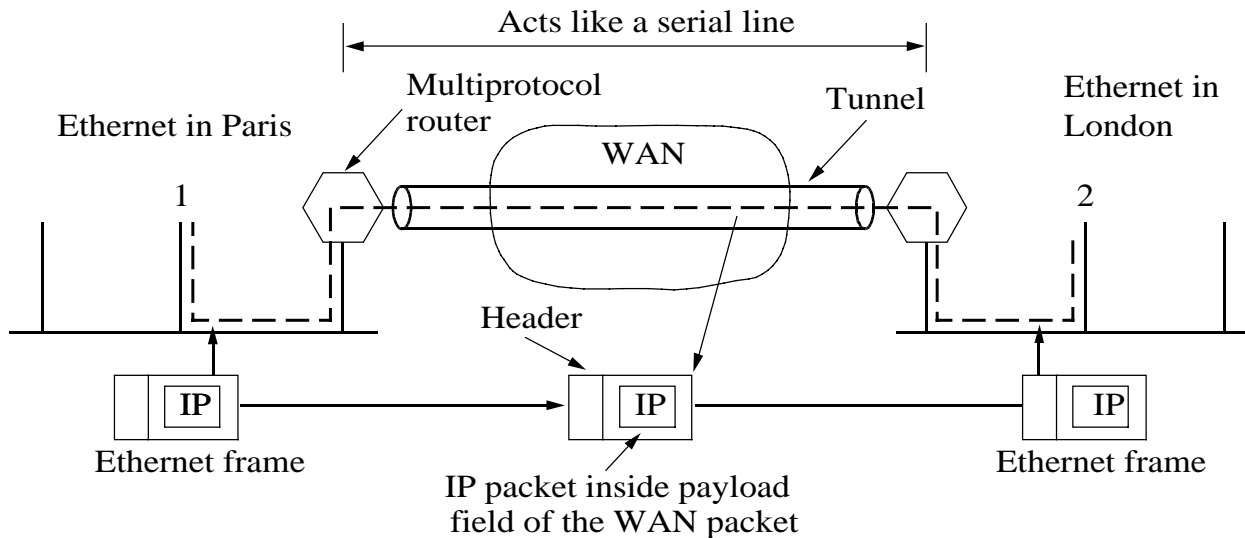

Internet Routing

- Use two levels of routing
- local (subnet) level routing
- Internet routing between multi-protocol gateways
 - multiple protocol gateways are generally fully connected
 - since they hide the underlying network
 - policies (politics) can dictate acceptable routes
 - don't route IBM packets on the Microsoft network
 - all packets starting and ending in Canada must stay in Canada
- Can use any of the standard routing algorithms
 - link-state
 - distance vector

Interior Gateway Routing Protocol

- Routes within a single Autonomous System (AS)
 - An AS contains
 - areas (collection of one or more subnets)
 - backbone (to interconnect areas within AS)
 - Also Called Open Shortest Path First (OSPF)
- Divides routers into four classes
 - Internal - only within the area
 - Area boarder routers - connect two or more areas
 - Backbone routers - connect to backbone
 - AS boundary routers - talk to other AS
- Exchanges info between adjacent routers
 - not the same as a neighbor since could have many hops in-between
- Uses link-state
 - flooding with sequence numbers
 - supports multiple metrics: throughput, reliability, delay
 - backbone computes inter-area routes

OSPF

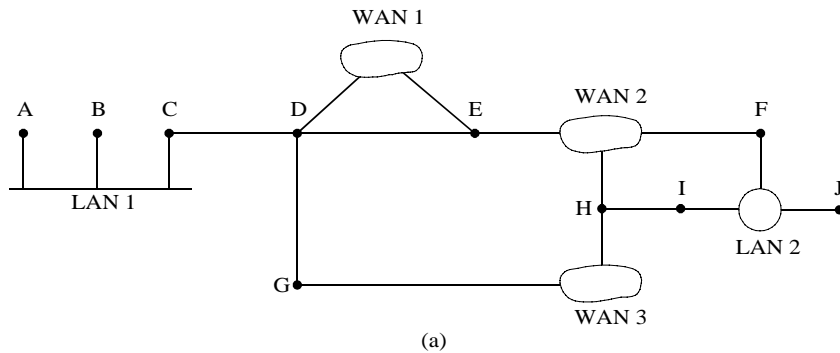

(a)

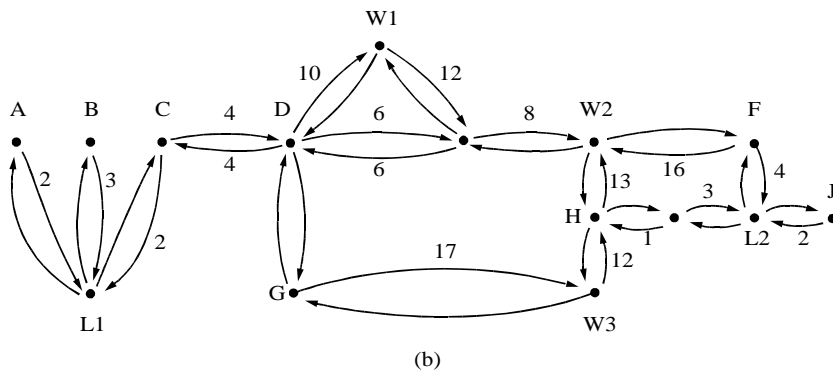

(b)

From: *Computer Networks*, 3rd Ed. by Andrew S. Tanenbaum, (c)1996 Prentice Hall.

Graph representation of an Autonomous system.

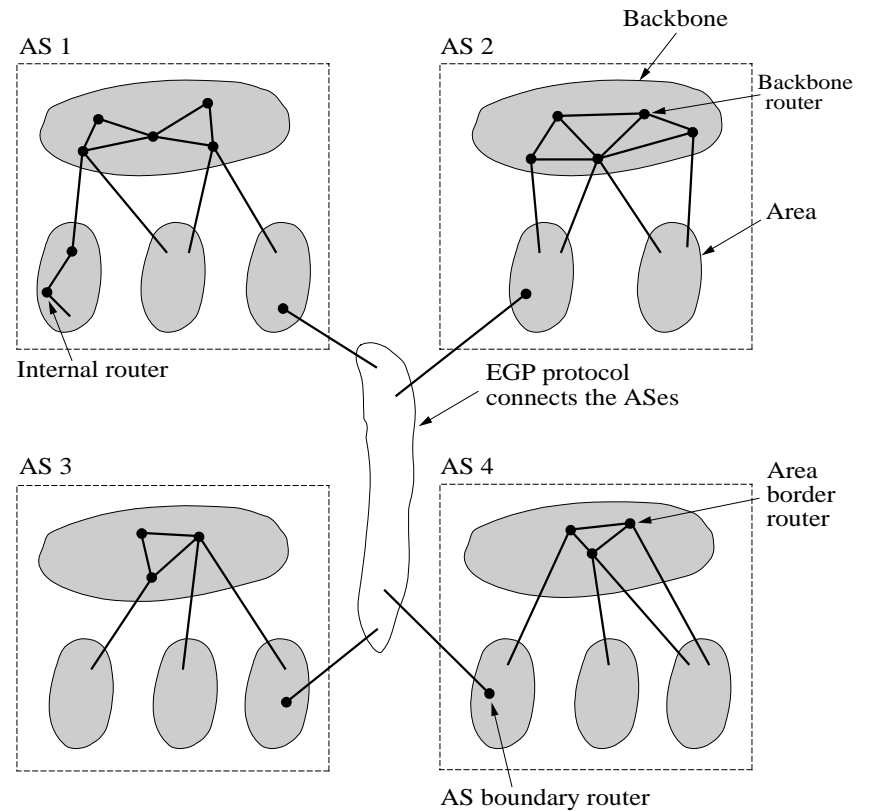

From: *Computer Networks*, 3rd Ed. by Andrew S. Tanenbaum, (c)1996 Prentice Hall.

Relationship between areas and ASes