

Announcements

- Program #0
 - its due next Friday
- Reading
 - Chapter 2
 - Chapter 3 (for Tuesday)

System Calls

- Provide the interface between application programs and the kernel
- Are like procedure calls
 - take parameters
 - calling routine waits for response
- Permit application programs to access protected resources

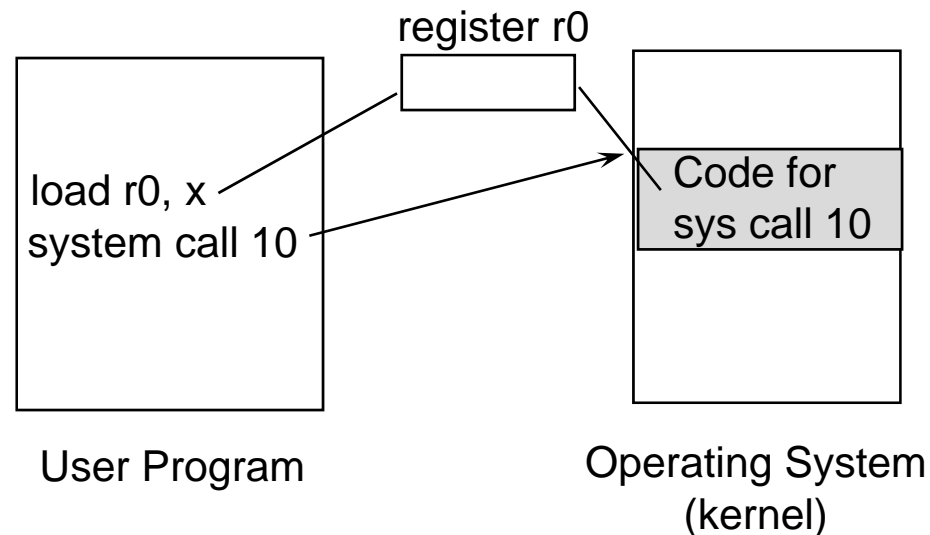

System Call Mechanism

- Use numbers to indicate what call is made
- Parameters are passed in registers or on the stack
- Why do we use indirection of system call numbers rather than directly calling a kernel subroutine?
 - provides protection since the only routines available are those that are export
 - permits changing the size and location of system call implementations without having to re-link application programs

Types of System Calls

- **File Related**
 - open, create
 - read, write
 - close, delete
 - get or set file attributes
- **Information**
 - get time
 - set system data (OS parameters)
 - get process information (id, time used)
- **Communication**
 - establish a connection
 - send, receive messages
 - terminate a connection
- **Process control**
 - create/terminate a process (including self)

Computer Systems

- Computers have many different devices

- I/O Devices
- Memory
 - volatile storage
- Processor(s)

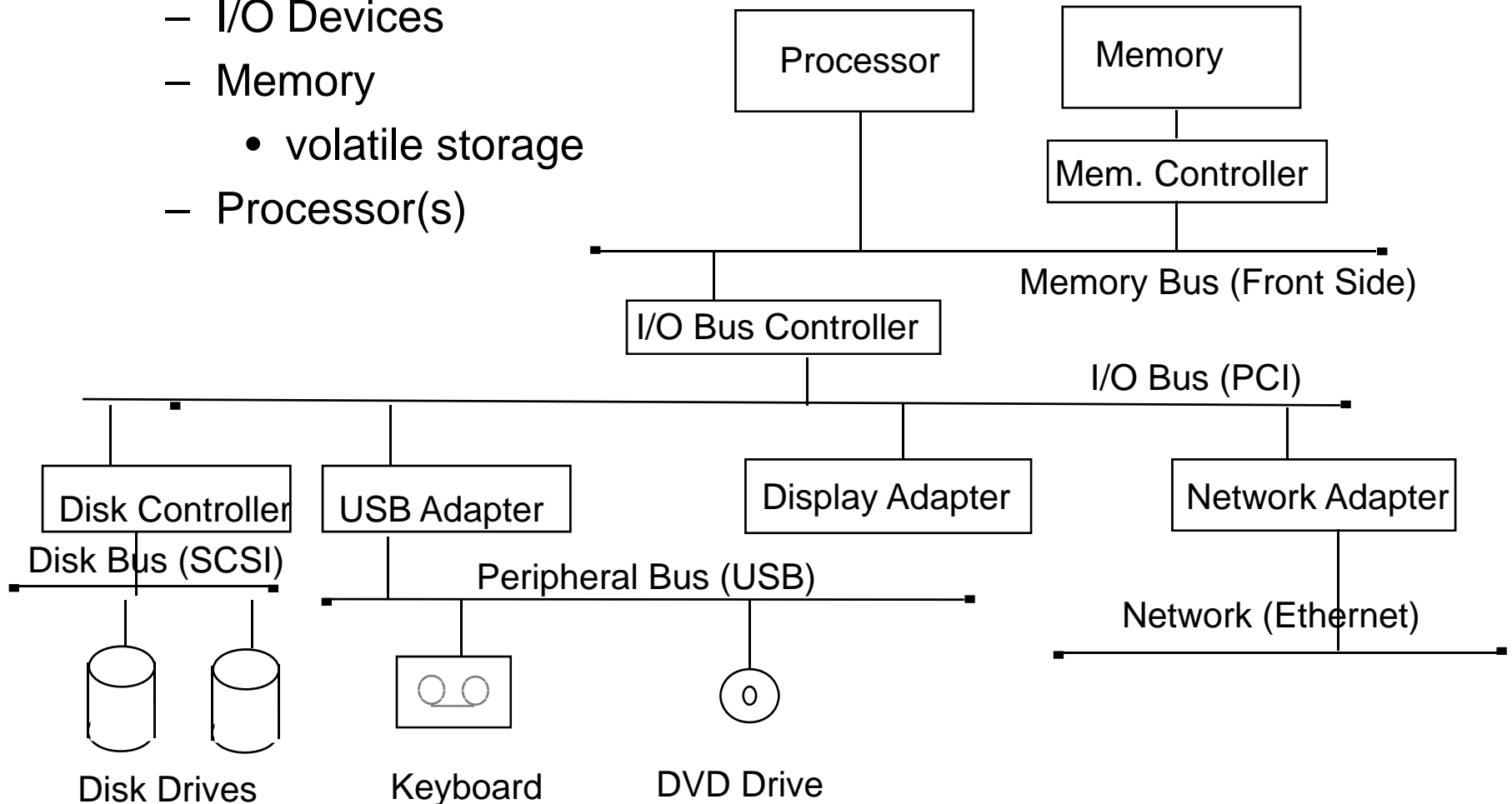

I/O Systems

- Many different types of devices
 - disks
 - networks
 - displays
 - mouse
 - keyboard
 - tapes
- Each have a different expectation for performance
 - bandwidth
 - rate at which data can be moved
 - latency
 - time from request to first data back

Different Requirements lead to Multiple Buses

- Processor Bus (on chip)
 - Many Gigabytes/sec
- Memory Bus (on processor board)
 - Up to 100 Gigabyte per second
- I/O Bus (PCI & PCI-E)
 - ~1s gigabytes per second
 - buses are more complex than we saw in class
 - show PCI spec.
- Device Bus (SCSI, USB)
 - tens of megabytes per second

Issues In Busses

- Performance

- increase the data bus width
- have separate address and data busses
- block transfers
 - move multiple words in a single request

- Who controls the bus?

- one or more bus masters
 - a bus master is a device that can initiate a bus request
- need to arbitrate who is the bus master
 - assign priority to different devices
 - use a protocol to select the highest priority item
 - daisy chained
 - central control

Disks

- Several types:
 - Hard Disks - rigid surface with magnetic coating
 - Floppy disks - flexible surface with magnetic coating
 - Optical (CDs and DVDs) - read only, write once, multi-write
 - Solid State (Flash) – fast seek times, limited number of writes
- Hard Disk Drives:
 - collection of platters
 - platters contain concentric rings called tracks
 - tracks are divided into fixed sized units called sectors
 - a cylinder is a collection of all tracks equal distant from the center of disk
 - Current Performance:
 - capacity: gigabytes to terabytes
 - throughput: sustained < 20 megabytes/sec
 - latency: mili-seconds

I/O Interfaces

- Need to adapt Devices to CPU speeds
- Moving the data
 - Programmed I/O
 - Special instructions for I/O
 - Mapped I/O
 - looks like memory only slower
 - DMA (direct memory access)
 - device controller can write to memory
 - processor is not required to be involved
 - can grab bus bandwidth which can slow the processor down

I/O Interrupts

- **Interrupt defined**
 - indication of an event
 - can be caused by hardware devices
 - indicates data present or hardware free
 - can be caused by software
 - system call (or trap)
 - CPU stops what it is doing and executes a handler function
 - saves state about what was happening
 - returns where it left off when the interrupt is done
- **Need to know what device interrupted**
 - could ask each device (slow!)
 - instead use an interrupt vector
 - array of pointers to functions to handle a specific interrupt