

# GeekOS Overview

A. Udaya Shankar  
[shankar@cs.umd.edu](mailto:shankar@cs.umd.edu)

Jeffrey K. Hollingsworth  
[hollings@cs.umd.edu](mailto:hollings@cs.umd.edu)

2/12/2014

## Abstract

This document gives an overview of the GeekOS distribution (for 412- Spring 2014) and related background on QEMU and x86. It describes some operations in GeekOS in more detail, in particular, initialization, low-level interrupt handling and context switching, thread creation, and user program spawning.

## Contents

1.	Introduction .....	2
2.	Qemu .....	3
3.	Intel x86 real mode .....	4
4.	Intel x86 protected mode .....	5
5.	Bootng and kernel initialization.....	8
6.	Context switching .....	11
6.1.	Context state .....	11
6.2.	Stopping and resuming threads .....	11
6.3.	Handle_Interrupt .....	12
6.4.	Switch_To_Thread(threadptr) .....	12
7.	Starting threads and spawning user programs .....	13
7.1.	Starting a kernel thread.....	13
7.2.	Starting a user thread.....	13
7.3.	Spawning a user program.....	13
8.	Filesystem overview .....	14
9.	Vfs .....	15
10.	Pfat.....	17
11.	Geekos/fileio.h.....	21
12.	Bufcache .....	22
13.	Blockdev .....	23
14.	Ide.....	25
15.	OS subsystems .....	26
15.1.	Utilities .....	26
15.2.	Memory system .....	26
15.3.	Process management .....	26
15.4.	Interrupt system.....	26
15.5.	Syscall system .....	27
15.6.	Device drivers .....	27
15.7.	Console.....	27
15.8.	File system .....	27
16.	Memory organization after setup and after Main.....	28

# 1. Introduction

The GeekOS distribution considered here is the one for CMSC 412 Spring 2014 from:

```
svn co https://svn.cs.umd.edu/repos/geekos/sping2014
```

It contains only source code (in C, x86 assembly (mostly NASM, some AT&T), Makefile, Perl). After executing the makefiles, it will also contain object code and executables that can run on a PC-like hardware platform (x86 processor, memory, IO devices, etc). In this class, the hardware platform is simulated by QEMU.

The directories and files of the GeekOS are organized as follows:

- Directory `build` has makefiles for starting QEMU with GeekOS and user programs. Its subdirectories, which are initially empty, will hold object and executable modules. In particular, there will be two disk images: `diskc`, containing a PFAT filesystem with the GeekOS image and user programs; and `diskd`, initially raw and empty.
- Directories `src/geekos` and `include/geekos` contains the kernel code. Executed by QEMU's processor in kernel mode. You will be adding and modifying significant parts of the files here. You should understand very well what is already there in order to have any hope of gracefully completing the projects.
- Directory `src/user` contains user programs that run on GeekOS. Executed by QEMU's processor in user mode.
- Directory `src/libc` contains C entry functions for system calls. User programs call these functions to obtain OS services. Executed by QEMU's processor in user mode (but switches to kernel mode while executing system calls). Header files are in directory `include/libc`.
- Directory `src/common` has heap manager `bget`, output formatter `fmtout`, string manipulation `string`, and `memmove`. Nothing specific to operating systems here. Header files are in directory `include/libc`.
- Directory `src/tools` contains code for constructing the disk images that is supplied to QEMU. In particular, `buildFat.c` constructs the PFAT file system on disk.
- Directory `scripts` contains Perl scripts, some of which are used in the makefiles.

## 2. Qemu

QEMU simulates a PC-like hardware. The QEMU configuration achieved by makefile includes the following. Below addresses are referred to by their hex values or their source code names or both, for example, “0xB800” or “VIDMEM\_ADDR” or “0xB800 / VIDMEM\_ADDR”.

- Processor: Intel 386.
- BIOS: When QEMU is started (corresponding to power up), BIOS loads diskc/sector 0 into memory at offset 0 of memory segment 0x07C0 (mapping to memory address 0x07C00), and the processor starts executing at that address. Thus that disk sector should contain the boot sector.
- Memory: 10 MBytes.
- PIC (programmable interrupt controller, 8259A): receives interrupts from IO devices (keyboard, dma, ide, floppy drive) and funnels them to the processor.  
Ports: 0x20, 0x21, 0xA0, 0xA1 (for loading interrupt vectors?)
- PIT (programmable interval timer): generates interrupts at programmable interval.  
IRQ: 0 (to PIC)  
Ports: 0x40–43
- Keyboard  
IRQ: 1 (to PIC)  
Ports: 0x64 / KB\_CMD; 0x60 / KB\_DATA.
- VGA (monitor)  
Video memory: 0xB8000–0x100000; 0xB8000 / VIDMEM\_ADDR; CRT\_ADDR\_REG; etc.
- IDE: accomodates up to 4 hard disks.  
Drive 0 (diskc) has a PFAT file system with the GeekOS image and user programs.  
Drive 1 (diskd) is a raw “empty” disk (appears only in later projects).  
IRQ: ?  
Ports: 0x1F6  
IDE\_DRIVE\_HEAD\_REGISTER;  
IDE\_DATA\_REGISTER;  
IDE\_SECTOR\_COUNT\_REGISTER; etc.
- Floppy drive: Holds a 1.44MB floppy disk.  
IRQ: ?  
Ports: 0x3F0 (FDC\_BASE); FDC\_STATUS\_REG; FDC\_DATA\_REG; etc.
- DMA:  
Ports: 0x00  
(DMA\_BASE); DMA\_COMMAND\_REG; DMA\_STATUS\_REG; DMA\_REQUEST\_REG; etc.

### 3. Intel x86 real mode

The x86 processor can be in one of several modes. Only two of them, “real” mode and “protected” mode, are relevant for GeekOS. The processor starts in real mode upon power-up or reset. Here, it is a 16-bit machine (Intel 8086) with a linear address space of 1MB ( $=2^{20}$ ), addressed using a combination of a 16-bit segment and a 16-bit offset.

#### Registers

The processor has the following 16-bit registers (assembly names used below):

- Main registers: in each, the 8-bit halves are independently addressable.
  - AX: primary accumulator; halves AH (higher) and AL (lower).
  - BX: base, accumulator; halves BH and BL
  - CX: counter, accumulator; halves CH and CL
  - DX: accumulator, other functions; halves DH and DL
- Index registers:
  - SI: source index
  - DI: destination index
  - BP: base pointer
  - SP: stack pointer
- Status register:
  - Flags: carry, parity, auxiliary, zero, sign, trap, interrupt, direction, overflow
- Segment registers:
  - CS: code segment
  - DS: data segment
  - ES: extra segment
  - SS: stack segment
- IP: instruction pointer

#### Addressing

The processor can address 1MB ( $2^{20}$  bytes) of memory. A 20-bit memory address is constructed by combining a 16-bit segment (from a segment register) and a 16-bit offset as follows:

- $16 \times \text{segment} + \text{offset}$  // equivalently:  $(\text{segment} \ll 4) + \text{offset}$  XXX

The address is usually denoted by `segment : offset`.

#### Stack, IO, interrupts

The hardware stack grows towards lower memory addresses. Push and pop is in terms of 2-byte words. Stack top is pointed to by SS:SP. Stack bottom is pointed to by SS:FFFF.

16-bit IO (port) address space, each referencing an 8-bit IO register. There are 256 interrupts (hardware and software).

## 4. Intel x86 protected mode

The x86 processor switches from real mode to protected mode upon executing a certain instruction. In protected mode, the processor is a 32-bit machine with many more features, some of which are described next.

The processor can switch between 4 privilege levels: 0–3, in decreasing order of privilege; 0 is kernel mode and 3 is user mode. A task has a separate stack for each level.

The linear address space is 4GB ( $=2^{32}$ ).

16-bit IO (port) address space, each referencing an 8-bit IO register. There are 256 interrupts (hardware and software).

### Segmented memory

The linear address space can be segmented, with an address being formed by combining a 16-bit “segment selector” and a 32-bit “offset”. Briefly, the segment selector indexes into a “segment descriptor table” in memory, which yields a 64-bit “segment descriptor” that points to a segment (in memory). There is a “global descriptor table” (GDT) and zero or more “local descriptor tables” (LDTs).

A **segment selector** contains the following:

- 1 bit: indicates GDT or LDT.
- 13 bits: index into GDT or LDT.
- 2 bits: protection level of segment.

A **segment descriptor** contains the following:

- linear base address of a segment: 32 bits
- limit (size) of the segment: 20 bits
- descriptor privilege level (dpl): 2 bits
- type of segment (data, code, system, tss, gate): 4 bits
- present (i.e., in memory): 1 bit
- Various 1-bit attributes

The GDT (global descriptor table) entries point to kernel segments and optionally user segments. GDT entry 0 cannot be used to access memory but it does serve as a “null segment selector”. There is a GDTR register in the processor that points to the GDT.

An LDT (local descriptor table) is like the GDT except that it is local to task (its entries point to segments of that task) and entry 0 can be used to access memory. There can be zero or more LDTs in memory. (In GeekOS, each user process gets an LDT.) There is a LDTR register in the processor that points (via the GDT) to the LDT currently being used (if any).

### Paging

Linear or segmented memory modes can be direct (no paging) or paged. If paged, the linear address is [dir, table, offset]:

- dir: indexes into page directory, yields base addr of page table
- table: indexes into page table, yields base addr of page
- physical addr = [page base addr, offset]

## Interrupts and task switching

An interrupt indexes into an “interrupt descriptor table” (IDT) in memory, which yields a 64-bit “gate” that points to the interrupt handler and indicates its privilege level. There is a IDTR register in the processor that points to the IDT.

If the interrupt handler’s privilege level is numerically lower than that of the interrupted task, the processor also switches to another stack. The location of this new stack is available in a “task state segment” (TSS) in memory, which is pointed to by a task register (TR) in the processor.

(The TSS can also be used to automatically store and retrieve the rest of the processor’s state upon a task switch. But GeekOS does not exploit this feature: it maintains only one TSS and uses it only for the stack pointer; it saves and loads the rest of the processor state in software.)

An **interrupt gate** contains the following:

- segment selector (for the segment containing the handler code): 16 bits
- offset within segment (pointing to the handler code): 16 bits
- descriptor privilege level (dpl): 2 bits
- type of segment (data, code, system, tss, gate): 4 bits
- present (in memory): 1-bit

When a task is interrupted and the interrupt handler is at the *same privilege level* as the interrupted task: the processor pushes on the current stack the EFLAGS, CS, and EIP registers (i.e., pertaining to the interrupted task) and (for certain interrupts) an error code.

When a task is interrupted and the interrupt handler is at a *numerically lower privilege level*, a stack switch occurs. The SS and ESP for the stack to be used by the handler are obtained from the current TSS. On this new stack, the processor pushes the SS and ESP of the interrupted task and then (as before) the EFLAGS, CS, and EIP registers and error code (if present).

A “return from interrupt” IRET instruction undoes the above (including popping the interrupted task’s SS and ESP if they are saved on stack).

## Processor registers

The processor has the following registers.

- 8 general purpose registers (each 32-bit):  
 EAX: accumulator  
 EBX, ECX, ESI, EDI: pointers to data segment; counters  
 EDX: IO pointer  
 ESP: stack pointer (in SS segment)  
 EBP: pointer to data on stack (in SS segment)
- 6 segment registers (each has a 16-bit part + “invisible” 64-bit part):  
 CS: code segment register  
 SS: stack segment register  
 DS, ES, FS, GS: data segment registers  
 The 16-bit part is a segment selector. The 64-bit invisible part caches the segment descriptor (from GDT or LDT) pointed to by the segment selector.
- GDTR: 48-bit, points to GDT: 32 bits for GDT base addr, 16 bits for GDT size (in bytes).
- IDTR: 48-bit, points to IDT: 32 bits for IDT base addr, 16 bits for IDT size (in bytes).
- LDTR: 16-bit segment selector (+ invisible 64-bit); points (via GDT) to an LDT.
- TR: 16-bit segment selector (+ invisible 64-bit): points (via GDT) to a TSS.
- EIP: 32-bit instruction pointer (used with CS).
- EFLAGS: 32-bit status and control register: carry, overflow, sign, interrupt enable, new task, etc.

- CR0–CR4: 32-bit control registers: paging enable, cache enable, cache write-mode, protected/real mode, page fault, etc.
- Other registers: debug, memory type range, machine check, etc.

## 5. Booting and kernel initialization

Upon powering up the PC platform, BIOS loads diskc/sector 0 (of 512 bytes) at offset 0 of memory segment 0x07C0 (BOOTSEG) and the processor starts executing in real-mode from that address (0x07C00).

The makefiles have put `src/bootsect.asm` (in machine language) in that sector. Thus when the processor powers up, `src/bootsect.asm` is in memory starting at location `BOOTSEG:0` and the processor starts executing the machine instruction at that location. From this point until the kernel is completely initialized, the processor is the only active “thread” in the system. It does the following:

- `bootsect.asm`: from `BeginText` to `after_move`:  
Moves the 512 bytes at `BOOTSEG:0` to `INITSEG:0` and jumps to `INITSEG:0`.
- `bootsect.asm`: from `after_move` to `load_kernel`:  
Loads the diskc sector containing `setup.asm` to memory `SETUPSEG:0`.
- `bootsect.asm`: from `load_kernel` to `ReadSector`):  
Loads the diskc sectors containing the OS kernel image into memory starting at `KERNSEG:0`. Then jumps to location `SETUPSEG:0` and starts executing `setup.asm`.
- `setup.asm`: from `BeginSetup` to `setup_32`:  
Determines the size of extended memory available, kills the floppy motor (which is not used henceforth), points `GDTR` and `IDTR` to temporary GDT and IDT tables (in `setup.asm`), initializes A20 address line, initializes the PIC (to bypass BIOS), enters protected mode, and jumps to `setup_32` (setting the processor’s `CS` register to `KERNEL_CS`).
- `setup.asm`: from `setup_32` to just before `.returnAddr`:  
Sets data and stack segment registers (`DS`, `ES`, `FS`, `GS`, `SS`) to `KERNEL_DS`, pushes on the stack a `Boot_Info` struct and a pointer to the struct, then jumps to `KERNEL_CS:ENTRY_POINT` (which points to function `Main` in `geekos/main.c`).

The memory now looks as shown in Section 16 (under the column titled “At end of `setup`”).

The processor now starts executing `Main`, (in the file `main.c`) which initializes the OS. There is still only one “thread” executing. We refer to it as the “initial kernel thread”. In executing `Main`, this thread initializes the OS kernel and enters itself in the OS data structures, thus becoming a true thread.

- `Init_BSS` (defined in `geekos/mem.c`):  
Zeros the BSS (global variables area) of the kernel image.
- `Init_Screen` (defined in `geekos/screen.c`):  
Blanks the VGA screen and initializes its hardware cursor.
- `Init_Mem` (defined in `geekos/mem.c`):  
Calls `Init_GDT` (defined in `geekos/gdt.c`):
  - Creates the (permanent) GDT (static variable `s_GDT`).
  - Entry 1 points to the kernel code segment and entry 2 to the kernel data segment.
  - Loads the GDT base address and limit into `GDTR`.

Treats memory as a sequence of 4KB pages. Creates (in kernel memory) a list of `Page` structs corresponding to the memory pages, each storing the attributes of its page (kernel, available for users, allocated, etc). Global variable `g_pageList` points to the list. Also creates a list of the available pages (`s_freeList`).

Calls `Init_Heap` (defined in `geekos/malloc.c`) to initialize the kernel heap. (Malloc itself is implemented by `bget`.)

- `Init_CRC32` (skipped).



- `Init_TSS` (defined in `geekos/tss.c`):  
GeekOS uses a single TSS (static variable `s_theTSS`). Zeros the TSS struct, adds the TSS descriptor to GDT, updates LDTR.
- `Init_Interrupts` (defined in `geekos/int.c`):  
Calls `Init_IDT` (defined in `geekos/idt.c`):
  - Creates the (permanent) IDT (static variable `s_IDT`) with 256 interrupt gate entries (one for every exception and interrupt). The first 32 entries are for exceptions and traps. The remaining entries are for external interrupts, i.e., external interrupt `j` is mapped to entry `32+j`.
  - Each IDT entry points to an entry point in `geekos/lowlevel.asm`. [The latter gets a pointer to the appropriate interrupt handler function (from `g_interruptTable` in `idt.c`) and calls handler with the appropriate `Interrupt_State` argument.]
  - Each IDT entry is at kernel privilege level, except for the syscall trap, which is at user privilege level.

Installs a pointer to a dummy interrupt handler function in every `g_interruptTable` entry (in `idt.c`).

Loads the IDT base address and limit into IDTR.

- `Init_SMP` (defined in `geekos/smp.c`)  
Performs the steps to identify how many cores there are and get those cores running. Via a inter-processor interrupt (IPI), it starts the function `setup_2nd_32` (`geekos/setup.asm`) which get the new core into 32-bit mode and then calls `Secondary_Start` (`geekos/smp.c`). `Secondary_Start` then calls:
  - `Init_GDT()`
  - `Init_TSS()`
  - `Init_Interrupts(CPUid)`
  - `Init_Secondary_VM()`
  - `Init_Scheduler()`
  - `Init_Traps();`
  - `Init_Local_APIC()`
  - `Init_Timer_Interrupt()`

The secondary cores are then left spinning until the function `Release_SMP` is called later in `Main`.

- `Init_VM` (define in `geekos/paging.c`)
- `Init_Scheduler` (defined in `geekos/kthread.c`):  
Creates a `Kernel_Thread` object for the initial kernel thread and indicates that as the currently executing thread (`g_currentThread`). (At this point, the initial kernel thread becomes a true OS thread.)  
Creates an idle thread (runs when there is no other thread to run) and makes it runnable.  
Creates a reaper thread (responsible for cleaning up terminated threads) and makes it runnable.  
Initializes some queues of pointers to `Kernel_Thread` objects: `s_allThreadList` is a list with an entry for every thread; `s_runQueue` is a queue with an entry for every runnable thread; and `g_currentThreads[]` indicates the currently executing thread (one element per core).
- `Init_Traps` (defined in `geekos/trap.c`):  
Installs interrupt handlers for interrupts 12, 13 and 0x90 (syscall) (in `g_interruptTable`). The handler for interrupt 12 (stack exception) terminates the current thread. The handler for interrupt 13 (general protection failure) terminates the current thread. The handler for interrupt 0x90 calls the syscall handler function.
- `Init_Local_APIC` defined in (`geekos/smp.c`) initializes the local interrupt controller.

- `Init_Timer` (defined in `geekos/timer.c`): Initializes the timer. Installs interrupt handler for timer interrupt (IRQ 0, corresponding to IDT entry 32). Enables timer interrupt.
- `Init_Keyboard` (defined in `geekos/keyboard.c`): Initializes the keyboard state. Installs interrupt handler for keyboard interrupt (IRQ 1, corresponding to IDT entry 33). Enables keyboard interrupt.
- `Init_DMA` (defined in `geekos/dma.c`): Resets the DMA controller.
- `Init_Floppy` (defined in `geekos/floppy.c`): (skipped)
- `Init_IDE` (defined in `geekos/ide.c`): Reset the IDE controller and drives. Start “IDE request” thread, to wait for requests to IDE. (Why no interrupt handler?)
- `Init_PFAT` (defined in `geekos/pfat.c`): Registers the PFAT file system interface to the virtual file system.
- `Init_GFS2`, `Init_GOSFS` start all of the different filesystem types.
- `Init_Alarm` sets up the alarm system so kernel threads can request alarms to happen.
- `Init_Network`, ...`Init_RIP`: (skipped) start the threads associated with the networking stack.
- `Release_SMP` allows all of the secondary cores to start running (and they quickly finish their initial threads and start running the Idle thread for that core).
- `Mount_Root_FileSystem`: mounts the root drive (`diskc`) as a PFAT file system to the virtual file system (in `vfs.c`) at root prefix “/”.
- `Spawn_Init_Process`: starts the user shell program.

## 6. Context switching

### 6.1. Context state

The context state of a thread is stored in three structures, all reachable from the first:

- A `Kernel_Thread` struct (defined in `geekos/kthread.h`). This contains the kernel stack pointer, various kernel-related state (refcount, pid, etc.), and pointers to stack and user context (see below).
- A stack page. This is the kernel stack of the thread. When the thread is not executing, the *processor* state of the thread is stored here as follows:  
`XX userSS, userESP [present only if thread was stopped in user mode] // stack interior`  
`XX eflags,`  
`XX eip (= return address),`  
`XX cs (= code segment selector),`  
`XX error code, interrupt number,`  
`XX gp and seg registers // stack top`  
 Thus the thread can be resumed simply by popping the gp and seg processor registers, clearing the error code and interrupt number, and executing “return from interrupt” (IRET).
- A `User_Context` struct (defined in `geekos/user.h`). This is present only if the thread is a user thread, i.e., started by spawning a user program. It contains user-level OS state (LDT, code/data/stack selectors, entry address, etc.).

### 6.2. Stopping and resuming threads

The context switching code appears in the following two functions (both in file `lowlevel.asm`):

- `Handle_Interrupt`:  
 Assumes that the current thread got here via an interrupt (external, trap, or exception).  
 Constructs the interrupt state of the current thread, calls the C interrupt handler, and finally either resumes the current thread or switches it out and switches in a thread from the run queue.
- `Switch_To_Thread`:  
 Assumes the following (verify each and check if it matters):
  - the current thread got here via a call (not an interrupt) with a thread pointer arg on stack;
  - the current thread has already been moved to the run/wait queue;
  - if the current thread has a user context then it is exiting (Is this important? ).
 Constructs the context of the current thread and switches in the thread pointer’s thread.

In both functions, the context switching code makes use of the kernel stack of the current thread (i.e., the one to be switched out). Think about what can go wrong if this is not done properly.

### 6.3. Handle\_Interrupt

- // here on (external or trap) interrupt; stack as follows:  
 // [userSS, userESP] (if user mode was interrupted), [stack interior  
 // eflags, cs, eip, error code, intrpt num [stack top]
- // save interrupt state of current thread on stack and call C handler  
 push gp and seg registers // completes interrupt state on stack  
 push esp // pointer to interrupt state  
 call C interrupt handler // get address from g\_interruptTable in int.c
- if current thread is to be switched out // according to g\_preemptionDisable,  
 g\_needReschedule  
 XX // NOTE: using previous thread's kernel stack  
 XX move current thread to run queue;  
 XX get a thread from run queue and make current;  
 XX set esp to its kernel stack (avail in thread's context).
- process signal if present // not present in distribution
- activate user context if thread has one // update LDTR, s\_TSS.esp0, s\_TSS.ss0, etc.
- pop gp and segment registers
- IRET

### 6.4. Switch\_To\_Thread(threadptr)

- // switch out current thread (it has already been moved to run/wait queue? )  
 // switch in the thread pointed to by threadptr (latter on stack)  
 // here on a call from Schedule (and not from an interrupt).  
 // current thread has no user context or is exiting. (Correct? )  
 // Stack: threadptr (= arg to Switch\_To\_Thread) [stack interior]  
 // Stack: return addr in Schedule (= eip) [stack top]
- change current thread's stack to following (so it can be switched in later):  
 XX threadptr, // stack interior  
 XX eflags,  
 XX return addr in Schedule (= eip),  
 XX fake error code, fake intrpt num,  
 XX gp and seg registers // stack top  
 save esp and clear numTicks on current thread struct  
 // current thread's context is now saved accurately
- // switch in threadptr's thread  
 // NOTE: using previous thread's kernel stack  
 restore esp to point to threadptr // pass over previous thread's interrupt state  
 make threadptr's thread current
- process signal if present // not present in distribution
- activate user context if thread has one // update LDTR, s\_TSS.esp0, s\_TSS.ss0, etc.
- pop gp and segment registers
- IRET

## 7. Starting threads and spawning user programs

### 7.1. Starting a kernel thread

`Start_Kernel_Thread(startFunc, arg, priority)`

- `Create_Thread`:
  - get memory for kthread struct and for stack;
  - initialize kthread fields: `stackPage`, `esp`, `numTicks`, `pid`, etc.
- `Setup_Kernel_Thread`:
  - configure kthread's stack so that when this kthread is switched in (in `lowlevel.asm`), it executes `Launch_Thread`, then `startFunc(arg)`, then `Shutdown_Thread`.  
Stack bottom:
 

```
startFunc arg, Shutdown_Thread addr, startFunc addr,
eflags (with intrpts off), KERNEL_CS (CS), Launch_Thread addr (EIP),
fake error code, fake intrpt number
fake gp registers, fake seg registers
```

 Stack top
- Add to `runQ`

### 7.2. Starting a user thread

`Start_User_Thread(userContext)`

- `Create_Thread`:
  - get memory for kthredd object and stack; initialize (as with kernel thread)
- `Setup_User_Thread`:
  - point `kthrd.userContext` to `userContext`
  - fix up (kernel) stack as above except:
    - X first push `userSS` and `userESP` (avail from `usercontext`)
    - X have interrupts on in `eflags`
- Add to `runQ`

### 7.3. Spawning a user program

`Spawn(programPathname, command, userContext)`

- Load user prog:
  - get file from file system (`vfs.c`, `pfat.c`),  
unpack into elf header and content, extract `exeFormat(elf.c)`.
  - get max virtual address of program and `argBlockSize` (from `exeFormat`),  
acquire memory 1 for program segment, arg block and user stack,  
load program segment into memory 1,  
format `argblock` in memory 1,  
acquire memory 2 for `usercontext` and initialize fields (`size`, `ldt`, entry point).
- `Start_User_Thread(userContext)`

## 8. Filesystem overview

GeekOS has a virtual filesystem (VFS) onto which “concrete” filesystems, such as PFAT, GOSFS, GSFS2, and others are “mounted”. VFS acts as a wrapper to these mounted filesystems, allowing them to be accessed by users in a uniform manner. Initially VFS consists of just an empty root directory (“/”). At the end of OS initializing, the PFAT filesystem in IDE 0 is mounted onto VFS at position “/c”, after which user programs can access the PFAT filesystem as the VFS subdirectory “/c”. Similarly, your GOSFS filesystem (in project 5) can be mounted at another point (say “/d”) and accessed.

GeekOS also has a virtual block device into which any block-structured storage device (e.g., IDE, floppy) can be registered. The block device acts as a wrapper to these registered storage devices, allowing them to be accessed in a uniform manner. The users in this case are other parts of the kernel (filesystems, paging, etc.).

The figure below illustrates the context. User programs invoke system calls, which invoke functions in `vfs.c`, which invoke functions in `pfat.c` or `gosfs.c`, which invoke functions in `blockdev.c`, which in turn invoke functions in `ide.c`. (In project 5, you implement the functions in `gosfs.c`.)

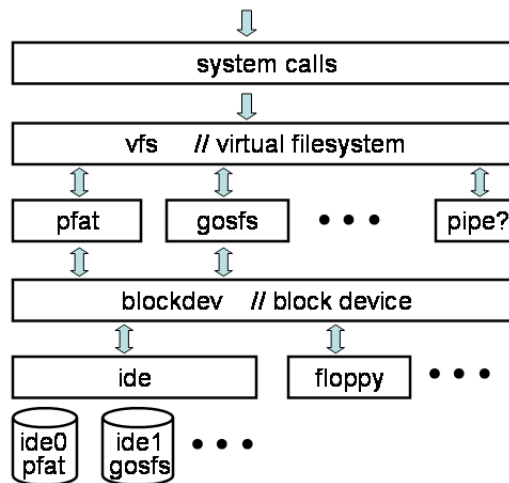

**Figure 1: GeekOS Filesystem Architecture.**

The `pfat` functions that are called by `vfs` have names of the form `PFAT_<function>` (see `pfat.c`). Similarly, the `gosfs` functions that are called by `vfs` have names of the form `GOSFS_<function>` (see `gosfs.c`). Note that `vfs` does not call these functions by name. Rather `vfs` gets pointers to these functions at run time (when a filesystem type is registered, when a filesystem is mounted, etc.).

## 9. Vfs

### Vfs functions called by “users”

(syscalls, main, other systems in the kernel)

[Sorry. Ignored \begin{astyped} ... \end{astyped}]  
 [Sorry. Ignored \begin{astyped} ... \end{astyped}]

### Vfs functions called by filesystem implementations

(pfat, gosfs)

[Sorry. Ignored \begin{astyped} ... \end{astyped}]

### Vfs static variables

- `s_vfsLock`: lock for ensuring atomicity of vfs operations.
- `s_mountPointList`: list of mountPoints, one for each mounted file system (e.g., pfat on dev1 at /c).
- `s_filesystemList`: list of fstypes (filesystem types), one for each registered filesystem (e.g., pfat).
- `s_pagingDevice`: registered paging device.  
Struct with following: fileName, blockDev, start sector, number of sectors

Each mountPoint is a struct containing the following:

- ops: pointers to functions `Open`, `Create_Directory`, `Open_Directory`, `Stat`, `Sync`, `Delete` in filesystem implementation (eg, pfat.c). (Note: `SetSetUid`, `SetAcl` omitted here.)  
Each function’s args: mountpoint, path in filesystem, mode, pfile.  
Pointers supplied by filesystem when mounted.
- prefix: where filesystem is mounted wrt root (eg, “/c”).
- blockDev: pointer to block device containing filesystem.
- fsData: filesystem info. Supplied by filesystem when mounted.

Each fstype is a struct containing the following:

- ops: pointers to functions `Format(blockDev)`, `Mount(mountPoint)` in filesystem implementation (eg, in pfat.c). pointers supplied by filesystem when registered.
- fsName: name of filesystemType (eg, “pfat”).

File struct for each opened file or directory containing:

- ops: pointers to functions `FStat`, `Read`, `Write`, `Seek`, `Close`, `Read_Entry` in filesystem implementation (eg, in pfat.c).  
Set by filesystem when mounted. Function args include `*file`.
- filePos: current position in file.
- endPos: end position in file (i.e., length of file).
- fsData: for use by filesystem implementation.
- mode: mode of open file (read vs write). Set by `Open()`, `Create_Directory()`, `Open_Directory()`.

- mountPoint: mountPoint of filesystem that file is part of. Set by Open(), Create\_Directory(), Open\_Directory().

**Functions in vfs**

Register\_FileSystem(fstype, fsOps):  
 add fstype to list of fstypes.

Format(\*devname, \*fstype):  
 if [fstype is registered and has Format] and [device is registered (in blockdev) and opens]  
 call fstype.ops.Format(device)

Mount(\*devname, pathPfx, \*fstype):  
 if [fstype is registered and has Format] and [device is registered (in blockdev) and opens]  
 create mountPoint(device, pathPfx), call fstype.ops.Mount(mountpoint), add mountPoint to  
 mountPointList.

Open(path, mode, pFile): // wrapper for mounted filesystem Open  
 split path into pfx and sfx  
 get mountPoint at pfx  
 call mountPoint.ops.Open(mountpoint, sfx, mode, pFile).

Close, Stat, FStat, Read, Write, Seek, Create\_Directory, Open\_Directory, Delete:  
 each is a wrapper for the corresponding mounted filesystem operation

Sync(): // wrapper for Sync of all mounted filesystems

ReadFully(path, buffer, pLen):  
 Stat(path)  
 Open(path)  
 Read repeatedly until all of stat.size is read



## 10. Pfat

### Pfat static variables

s\_pfatFileOps: XX // instance of File\_Ops (defined in vfs.h)

- &PFAT\_FStat
- &PFAT\_Read
- &PFAT\_Write
- &PFAT\_Seek
- &PFAT\_Close
- 0: // (Read\_Entry

s\_pfatDirOps: XX // instance of File\_Ops (defined in vfs.h)

- &PFAT\_FStat\_Dir
- 0, 0, 0, XXX// Read, Write, Seek
- &PFAT\_Close\_Dir
- &PFAT\_Read\_Entry

s\_pfatMountPointOps: XX // instance of Filesystem\_Ops (defined in vfs.h)

- PFAT\_Open
- 0, // Create\_Directory()
- PFAT\_Open\_Directory,
- PFAT\_Stat
- PFAT\_Sync
- 0 //Delete

s\_pfatFilesystemOps: XX // instance of Filesystem\_Ops (defined in vfs.h)

- 0 // Format
- &PFAT\_FStat\_Dir

### Pfat structs

bootSector:

- magic: filesystem id
- fatOffset: start of FAT
- fatLength: length of FAT (in sectors? )
- rootDirectoryOffset: start of root directory
- rootDirectoryCount: number of items in root directory
- setupStart
- setupSize
- kernelStart
- kernelSize

directoryEntry:

- filename: 8 + 4 chars (including null terminator). 12 bytes
- readOnly, hidden, systeFile, volumeLabel, directory: each 1 bit
- time: 2 bytes
- date: 2 bytes
- firstBlock: 4 bytes
- fileSize: 4 bytes

PFAT\_Instance: XX // in-memory info of mounted PFAT fs; kept in mountpoint.fsInfo.

- fsinfo: bootsector instance
- \*fat: pointer to fat table
- \*rootDir: pointer to rootDirEntry
- rootDirEntry:
- lock:
- fileList: PFAT file list

PFAT\_File: XX // in-memory info of open PFAT file; kept in file.fsInfo.

- fsinfo: bootsector instance
- entry: directory entry of this file.
- numBlocks: number of blocks of file
- \*fileDataCache:
- \*validBlockSet: which data blocks of cache are valid

### Pfat public functions

All exported when pfat filesystem is mounted.

PFAT\_FStat(\*file, \*stat):

copy file.fsData info into stat

PFAT\_Read(\*file, \*buf, numBytes):

// this function accesses file.fsData and file.mountPoint.fsData  
 set numBytes to min(endPos, filePos + numBytes)  
 traverse FAT (in file.mountpoint.fsData) for blocks of the file  
 XX for each block that is not in cache or not clean, read it into cache  
 copy relevant cache buffers into buf  
 update filePos  
 copy file.fsData info into stat

PFAT\_Write(\*file, \*buf, numBytes):

return EACCESS XX // writes not allowed

PFAT\_Seek(\*file, pos):

set file.filePos to pos if in range

PFAT\_Close(\*file, pos):

return 0 XX // no-op

PFAT\_FStat\_Dir(\*dir, \*stat):

copy file.mountPoint.fsData.rootDirEntry into stat XX // only one directory

PFAT\_Close\_Dir(\*dir):

return 0 XX // no-op

```
PFAT_Read_Entry(*dir, *entry):
```

```
  if dir.filePos ≥ dir.endPos
  XX return VFS_NO_MORE_ENTRIES
  pfatDirEntry ← dir.mountPoint.fsData.rootDir[dir.filePos++]
  copy pfatDirEntry to entry.name.states
```

```
PFAT_Open(*mountPoint, *path, mode, **pFile):
```

```
  if (mode is not O_READ) or (path is not a file entry in mountPoint.fsData)
  XX return errorcode
  get a pfatFile object for path XX // already cached?, else cache, etc.
  create vfs file object (with pfatFileOps, pfatFile, etc) and return in **pFile
```

```
PFAT_Open_Directory(*mountPoint, *path, mode, **pDir):
```

```
  if (path is not "/")
  XX return errorcode
  create vfs File object and set object's
  XX ops to s_pfatDirOps
  XX filePos to 0
  XX endPos to mountPoint.fsData.fsinfo.rootDirectoryCount
  XX fsData to 0
  return pointer to File object via **pDir
```

```
PFAT_Stat(*mountPoint, *path, *stat):
```

```
  get pfatfile object for path from mountPoint.fsData
  copy info from pfatfile object into stat
```

```
PFAT_Sync(*mountPoint):
```

```
  return 0 XX // no-op; read-only fs
```

```
PFAT_Register_Paging_File(*mountPoint, *pfatInstance):
```

```
  return if paging device already registered (Get_Paging_Device())
  get dirEntry for file with PAGEFILE_FILENAME ("pagefile.bin"?)
  create pagedev and set its
  XX fileName to mountPoint.pathPfx + PAGEFILE_FILENAME
  XX dev to mountPoint.dev
  XX startSector to dirEntry.firstBlock
  XX numSectors to dirEntry.fileSize / SECTOR_SIZE
  Register_Paging_Device(pagedev)
```

```
PFAT_Mount(*mountPoint):
```

```
  allocate pfatInstance and bootsect
  read mountpoint.dev's sector 0 into bootsect XX // using Block_Read
  copy bootsect's bootsector into pfatInstance.fsinfo
  return if fsinfo's magic number, FAT offset/size, root dir offset/size not ok
  allocate pfatInstance.fat XX // in-memory FAT; fsinfo.fatLength gives size in sectors
  read FAT from dev into pfatInstance.fat XX // using Block_Read
  allocate pfatInstance.rootDir XX // in-memory rootDir; fsinfo.rootDirCount gives size in entries
  read root directory from dev into pfatInstance.rootDir XX // using Block_Read
```

```
set psfatInstance.rootDirEntry's fields (read-only/directory/fileSize) X // fake root directory entry
initialize pfatInstance.lock
clear pfatInstance.fileList
PFAT_Register_Paging_File(mountPoint, pfatInstance) X // if present and unregistered
set mountPoint.ops to s_pfatMountPointOps
set mountPoint.fsData to pfatInstance XX
```

```
Init_PFAT(void):
    call vfs's Register_FileSystem("pfat", &s_pfatFilesystemOps)
```

## 11. Geekos/fileio.h

[Sorry. Ignored `\begin{astyped} ... \end{astyped}`]

*To be completed .....*

## 12. Bufcache

Comes between vfs/pfat/gosfs and blockdev.

No static variable. No local thread.

### Bufcache structs

FS\_Buffer: // holds one fsblock

- fsBlockNum: filesystem block number
- \*data: in-memory data of block. May be out of sync with disk.
- flags: state of buffer (dirty, pending, ...)

FS\_Buffer\_Cache:

- \*blockdev: associated device
- fsBlockSize: size of filesystem blocks
- numCached: current number of buffers (cached blocks)
- fsBufferList: list of buffers
- lock: lock for synchronization
- cond: condition variable for waiting for a buffer

### Bufcache public functions

All called by vfs/pfat/gosfs.

\*Create\_FS\_Buffer\_Cache(\*blockdev, fsBlockSize):  
 malloc cache struct and set fields

Sync\_FS\_Buffer\_Cache(\*cache):  
 lock cache, write out all dirty buffers, release lock

Destroy\_FS\_Buffer\_Cache(\*cache):  
 synch and release all buffers and cache struct

Get\_FS\_Buffer(\*cache, fsBlockNum, \*\*pBuf):  
 sets \*\*pBuf to buffer fsBlockNum

## 13. Blockdev

### Blockdev static variables

- `s_blockdevLock`: lock for ensuring atomicity of blockdev operations.
- `s_deviceList`: list of `blockDevices`, one for each registered block device (e.g., `ide`, `floppy`).

Each `blockDevice` is a struct of the following:

- `name`: name of block device.
- `*ops`: struct of pointers to functions `Open`, `Close`, `Get_Num_Blocks` in device driver (e.g., `ide.c`).  
Set when device is registered.  
Each function's arg: `*dev`.
- `unit`: device drive number
- `inUse`: opened?
- `*driverData`:
- `*waitQueue`: pointer to wait queue in device driver (e.g., `ide`). Set when device is registered. A server thread in device waits here.
- `*requestQueue`: pointer to request queue in device driver (e.g., `ide`). Set when device is registered. `BlockRequests` are queued here.

Each `blockRequest` is a struct of the following:

- `*dev`: block device.
- `type`: request type
- `blockNum`: number of block (to read, write, seek, ...)
- `*buf`: buffer for request
- `requestState`: pending, completed, error. (Volatile)
- `errorCode`: (Volatile)
- `waitQueue`: requesting thread waits here (until awakened by a server thread in device driver)

### Blockdev functions

`Register_Block_Device(devname, devOps, unit, driverData, waitQueue, requestQueue)`:

```
// called by device driver (e.g., ide.c)
malloc blockDevice struct, assign its fields, add to deviceList.
```

`Notify_Request_Completion(req, state, errorCode): XXXXX` // called by device driver (e.g., `ide.c`)

```
wakeup(req.waitQueue),
```

`*Dequeue_Request(reqQueue, waitQueue): XXXXX` // called by device driver (e.g., `ide.c`)

```
wait for non-empty requestQueue;
remove request from requestQueue and return it
```

`Block_Read(dev, blockNum, buf): XXXXX` // called by user (e.g., `vfs/pfat`, `vfs/gosfs`)

```
create blockRequest, add to req.dev.requestQueue
```

wakeup(req.dev.waitQueue)  
wait at req.waitQueue until req no longer pending

Block\_Write(dev, blockNum, buf) : // just like Block\_Read(.)

Open\_Block\_Device(devname, \*\*pDev) XX // wrapper for dev.Open(); called by user (e.g., vfs/pfat)

lookup devname in blockDeviceList, and call device's Open(), set pDev to device

Close\_Block\_Device(dev) XX // wrapper for dev.Close(); called by user (e.g., vfs/pfat)  
call dev.Close()

Get\_Num\_Blocks(dev) XX // wrapper for dev.get\_Num\_Blocks(); called by user (e.g., vfs/pfat)



## 14. Ide

### Ide static variables

- numDrives: number of drives (4)
- drives[i]: holds drive i's configuration (heads, cylinders, sectors/track, bytes/sector).
- s\_ideWaitQueue: ide wait queue. Exported when drive is registered.
- s\_ideRequestQueue: ide request queue. Exported when drive is registered.
- s\_ideDeviceOps: pointers to functions IDE\_Open, IDE\_Close, IDE\_Get\_Num\_Blocks; all have arg blockDev.

### Ide functions

IDE\_Open(\*blockDev): XXX // exported when drive is registered  
null-op if blockDev.inUse false, else crashes.

IDE\_Close(\*blockDev): XXX // exported when drive is registered  
null-op if blockDev.inUse true, else crashes.

IDE\_Get\_Num\_Blocks(\*blockDev): XXX // exported when drive is registered  
returns number of (disk) blocks in disk.

IDE\_Read(driveNum, blockNum, \*buffer):  
reads disk block, doing busy waiting

IDE\_Write(driveNum, blockNum, \*buffer):  
writes disk block; busy waiting.

IDE\_Request\_Thread(UNUSED arg):  
waits at ide wait queue (via blockdev.waitqueue) until awakened  
ide request queue  
dequeues request from ide request queue (via blockdev.requestqueue)  
calls IDE\_Read or IDE\_Write  
calls blockdev.Notify\_Request\_Completion.

Init\_IDE():  
reset IDE controller and turn off interrupts  
for each drive:  
XX read drive configuration and whether ATA or ATAPI  
XX register drive with blockdev  
start kernel thread on IDE\_Request\_Thread(UNUSED arg)

## 15. OS subsystems

Each subsection below identifies a “subsystem” of the OS and lists the associated files.

### 15.1. Utilities

The following files provide non-OS-specific functionality, such as debug macros, output formatting, strings, generic lists, linking maps, etc.

- `libc/bget.h`, `common/bget.c`, `geekos/bget.h`: heap structure.
- `malloc`: memory manager; wrapper for `bget`.
- `geekos/bitset.h-c`: bitset structure.
- `libc/fmtout.h`, `common/fmtout.c`, `geekos/fmtout.h`: output formatting.
- `geekos/ktypes.h`: aliases to integer and char types, min/max functions, etc.
- `geekos/kassert.h`: debugging macros (`KASSERT`, `TODO`, `PAUSE`, etc).
- `common/libuser.h`: includes user library (`conio.h`, `sema.h`, `sched.h`, `fileio.h`).
- `geekos/list.h`: generic list structure.
- `common/memmove.h`: standard “memory move” function.
- `geekos/range.h`: checking memory range containership.
- `libc/string.h`, `common/string.c`, `geekos/string.h`: string manipulation.
- `geekos/symbol.h-asm`: symbol mangling macros (for linking C and asm).

### 15.2. Memory system

Physical memory management: divides physical memory into 4KB pages, keeps track of the pages (kernel, user, free, kernel heap, etc.), gives out memory when needed (e.g., for process creation, data structures, etc.), gets back memory when released.

Files: `geekos/malloc.*`, `geekos/mem.*`.

Segmented memory management: implements segmentation over physical memory; creates segment selectors and descriptors, maintains GDT.

Files: `geekos/segment.*`, `geekos/gdt.*`.

### 15.3. Process management

Kernel process management: kernel thread state; thread queues; creation, deletion and switching of kernel threads; thread signalling and synchronization.

Files: `geekos/kthread.*`, `geekos/tss.*`, `geekos/lowlevel.asm` (function `Switch_To_Thread`).

User process management: augmenting kernel threads with user context and user process creation, deletion, switching. `libc/process.*`, `geekos/user.*`, `geekos/userseg.c`, `geekos/tss.*`, `geekos/lowlevel.asm` (function `Switch_To_Thread`).

User program loading: loading a user executable (obtained from disk) into memory.

Files: `geekos/elf.*`, `geekos/argblock.*`,

### 15.4. Interrupt system

This comprises the mapping from interrupt entry points (in IDT) to interrupt handlers and the mapping from interrupt handlers back to resuming the interrupted processes. Covers both external (hardware) interrupts and internal interrupts (exceptions, traps).

Files in geekos: `idt`, `int`, `irq`, `trap`, `lowlevel.asm` (function `Handle_Interrupt`, table `g_entryPointTable`).

### 15.5. Syscall system

Syscalls are all instances of a trap `0x90`; i.e., `trap.c` forwards it to the appropriate syscall handler.

Files in geekos: `trap` (function `Syscall_Handler`), `syscall`.

### 15.6. Device drivers

This comprises the functions for I/O on hardware devices and the interrupt handlers for handling interrupts issued by these devices.

Files in geekos: `timer`, `screen`, `keyboard`, `floppy`, `ide`, `dma`, `io`.

### 15.7. Console

The console is the user-level “device” consisting of keyboard and screen.

Files: `include/libc/conio.h`, `src/libc/conio.c`, `geekos/syscall` (handlers for syscalls in `conio`).

### 15.8. File system

This comprises the virtual file system, the user interface to the virtual file system, the concrete file systems (`pfat`, `gsfs2`, `gosfs`) that can be mounted on the virtual file system, and the block device interface to the hardware disk devices.

OS side (all in `geekos`): `vfs`, `pfat`, `gosfs`, `gsfs2`, `blockdev`, `bufcache`, `syscall` (`fileio` syscall handlers).

User side: `libc/fileio.*`.

## 16. Memory organization after setup and after Main

Address	Name(s) in source code	At end of setup	At end of Main
000000		start BIOS code/data (and PIC interrupt vectors)	
001000	PAGE_SIZE	end BIOS code/data	start available pages
007C00	BOOTSEG:0	bootsect loaded here by BIOS	
010000	KERNSEG:0 KERNEL_START_ADDR KERNEL_THREAD_OBJ  BSS_START  BSS_END  kernEnd	start kernel image      end kernel image	end available pages start kernel image  X kernel global X structures initialized  end kernel image start available pages
090000	INITSEG:0	bootsect reloaded here	
090200	SETUPSEG:0	setup loaded here	
090400	MEMMAPSEG:0	setup stack (grows towards 0)	
0A0000	ISA_HOLE_START	start ISA hole (hardware use)	end available pages
0B8000	VIDSEG:0	start video memory	
100000	ISA_HOLE_END KERN_THREAD_OBJ	end ISA hole start initial kernel thread object	start initial kernel thread object
101000	HIGHMEM_START KERN_STACK	initial kernel thread stack start of kernel heap	initial kernel thread stack start of kernel heap
111000	pageListEnd = HIGHMEM_START + X KERNEL_HEAP_SIZE  endOfMem	end of kernel heap	end of kernel heap start available pages  end available pages
FEE00000	APIC_Addr		Start of local APIC region
FEC00000	IO_APIC_Addr		Start of IO APIC region

Figure 2: GeekOS Memory Layout